

Assembly Instructions

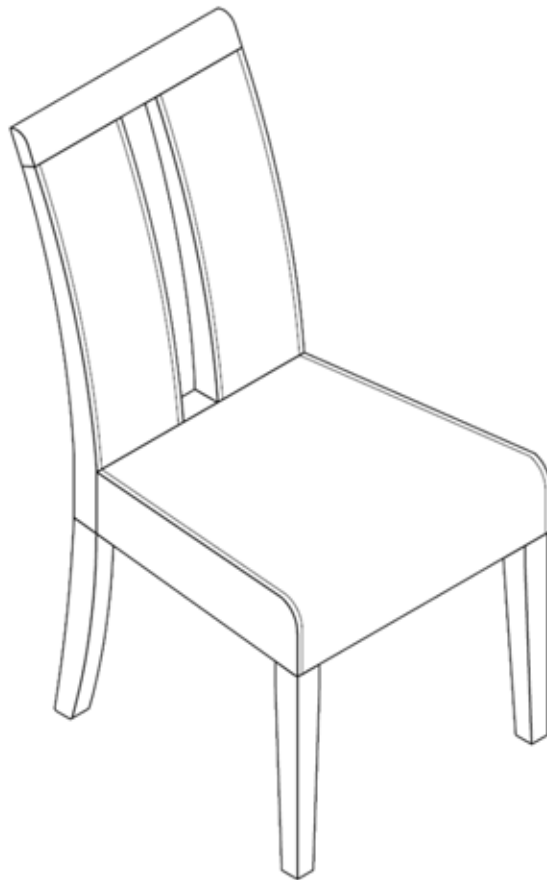

ASSEMBLY RATING

The Assembly Rating is a 5-point system that shows the degree of effort needed in assembling a specific product (with 1 being easy and 5 being difficult). For some products, two persons are recommended.

EASY  DIFFICULT

Tools Required for Assembly:

Allen Wrench



(Included)

ASSEMBLY & CARE ADVICE

FOR YOUR FURNITURE TO LAST, CORRECT ASSEMBLY AND PROPER MAINTENANCE ARE NECESSARY. PLEASE FOLLOW THE INFORMATION PROVIDED BELOW TO FULLY ENJOY YOUR FURNITURE.

BASIC ASSEMBLY TECHNIQUES

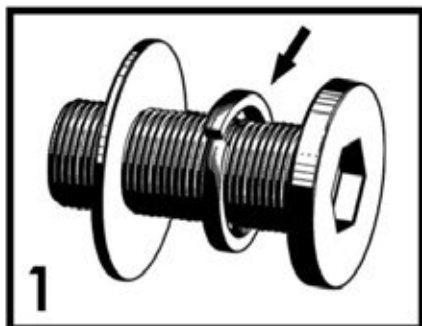

1 When lock or spring washer is used in an assembly, please make sure the lock or spring washer is placed between the larger flat washer and the head of the screw or bolt.



2 Position each part correctly and insert screws or bolts into their respective holes by hand tighten or using the proper hand tool. Only tighten when step is completed or when instructed to do so.

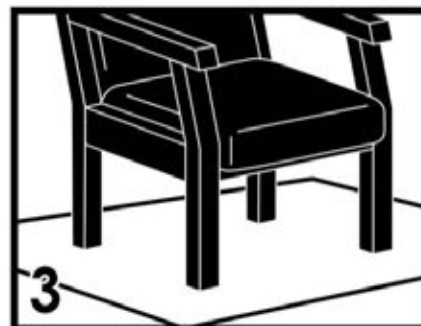

3 Use cardboard or carpet area when assembling furniture to prevent scratches. Make sure the furniture rests on a flat and level surface with each leg evenly touching the floor.

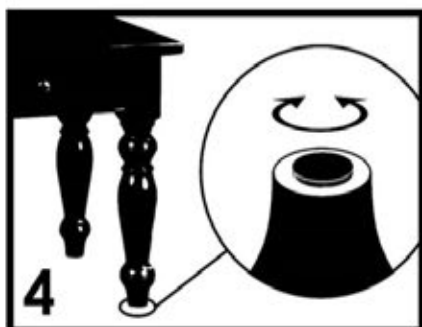

4 Some furniture comes with height adjustment knobs underneath each leg. To lower or to raise each leg, you need to turn clockwise or counterclockwise, respectively.

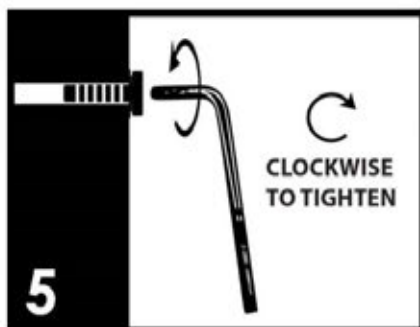

5 Make sure all parts are properly aligned, then use the appropriate hand tool to completely tighten the bolts or screws. Do not use power tools and do not overtighten.

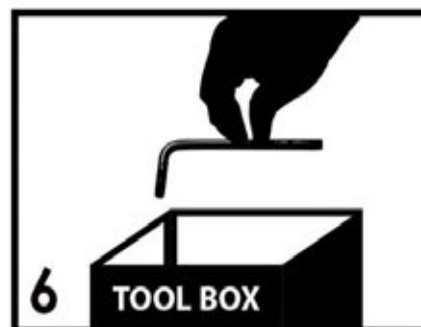

6 Save the instructions and store the Allen wrench or any supplied tool for later maintenance. After two weeks, check and tighten any loose hardware and repeat again every six months thereafter.

IT IS THE USER'S RESPONSIBILITY TO MAINTAIN THE FURNITURE. THE HARDWARE MAY LOOSEN OVER TIME AND MAY CAUSE THE FURNITURE TO BE WOBBLY AND UNABLE TO SUPPORT ITS INTENDED WEIGHT CAPACITY. THIS MAY LEAD TO COLLAPSE AND MAY CAUSE SERIOUS INJURY.



FAILURE TO FOLLOW THE GUIDELINES ABOVE MAY RESULT IN INJURY AND/OR PROPERTY DAMAGE.



Before you begin, please read Page 2 of "Assembly and Care Advice".

And remember, do not tighten until each step is completed or instructed.

MD

Parts List

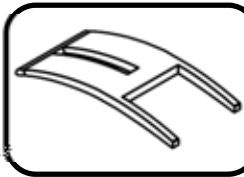

#1 x 1 pc
Back Rest w/ Legs

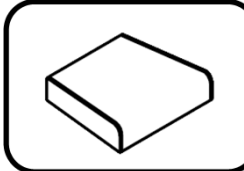

#2 x 1 pc
Seat Cushion

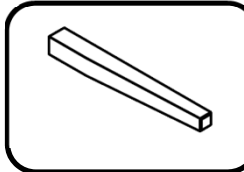

#3 x 2 pcs
Legs

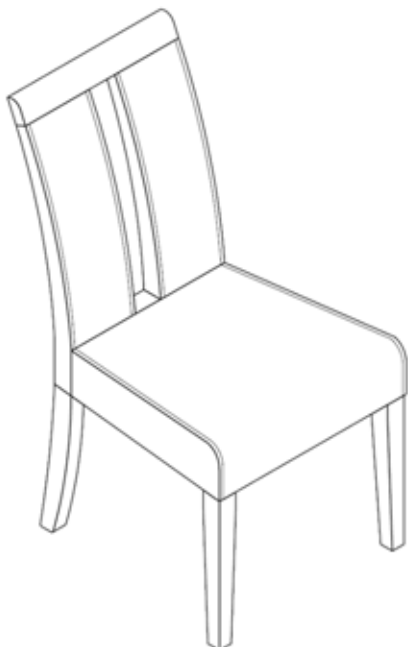

X 2

Hardware List

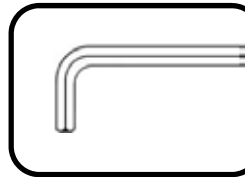

#A x 1 pc
Allen Wrench

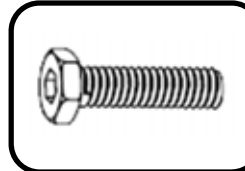

#B x 4 pcs
Bolt 5/16"x3-1/2"

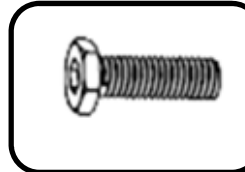

#C x 2 pcs
Bolt 5/16"x2"

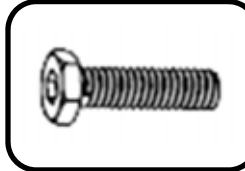

#D x 4 pcs
Bolt 5/16"x2-1/4"

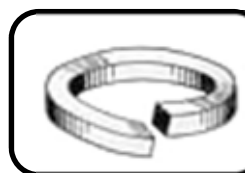

#E x 10 pcs
Lock Washer 5/16"

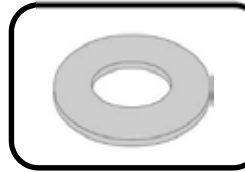

#F x 10 pcs
Flat Washer 5/16"

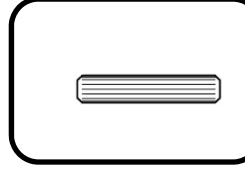

#G x 1 pc
Wood Dowel



Note: The above parts and hardware are shown for a complete assembly of ONE chair. However, the actual parts and hardware in the box will be twice the quantity.

- I. Place the back rest with legs (#1) on a protected surface. Insert the wood dowel (#G) to the center hole of the back rest with legs (#1).
- II. Align the seat cushion (#2) with the wood dowel (#G) and the pre-drilled holes of the back rest with legs (#1).
- III. Prepare 2 bolt assemblies by inserting FIRST the spring washer (#E) onto the bolt (#C) and then the flat washer (#F) onto the SAME bolt (#C), in that order.
- IV. Insert the bolt assembly through the hole between the wood dowel (#G) and the edge of the seat cushion (#2) and secure that bolt using the Allen wrench (#A) to lock it in with the back rest with legs (#1). Repeat for the other side.
- V. Prepare 4 bolt assemblies by inserting FIRST the spring washer (#E) onto the bolt (#B) and then the flat washer (#F) onto the SAME bolt (#B), in that order.
- VI. Insert 2 bolt assemblies through the two pre-drilled holes in the corner of the seat cushion (#2) and secure those bolts using the Allen wrench (#A) to lock it in with the back rest with legs (#1). Repeat for the other side.

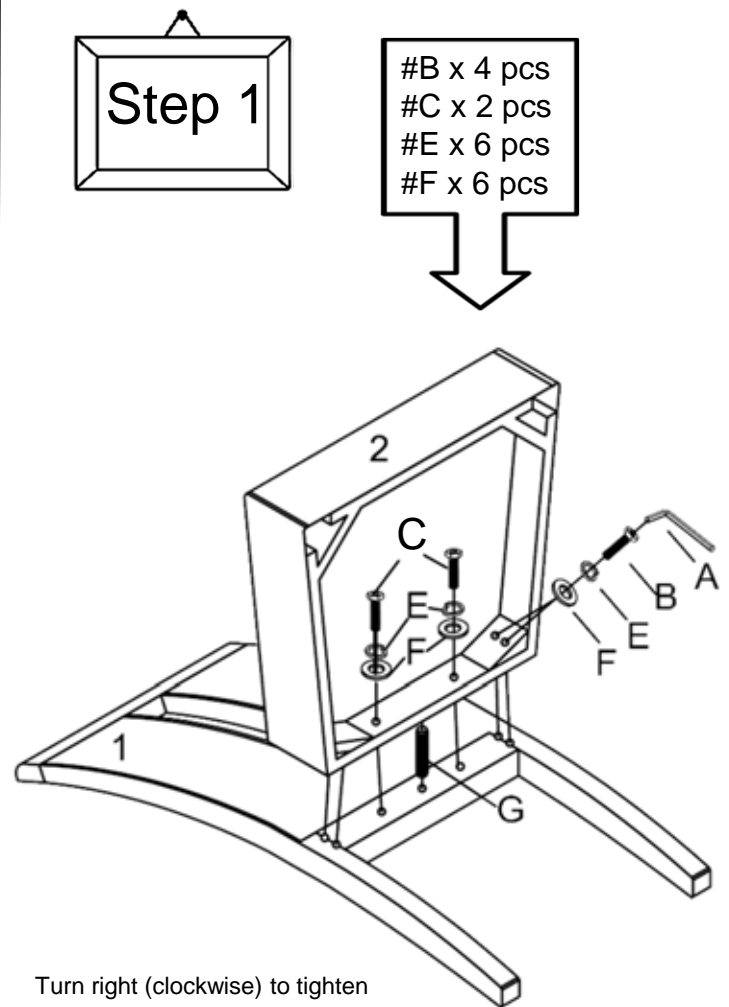

- I. Insert the 2 legs (#3) to align with the pre-drilled holes of the seat cushion (#2).
- II. Prepare 4 bolt assemblies by inserting FIRST the spring washer (#E) onto the bolt (#D) and then the flat washer (#F) onto the SAME bolt (#D), in that order.
- III. Insert 2 bolt assemblies through the two pre-drilled holes in the corner of the seat cushion (#2) and secure those bolts using the Allen wrench (#A) to lock it in with the leg (#3). Repeat for the other side.
- IV. Carefully turn the completed chair upright. Make sure the chair is rested on a flat surface and it does not feel loose or wobbly. If it does, double check that the bolts are secured and properly tightened.

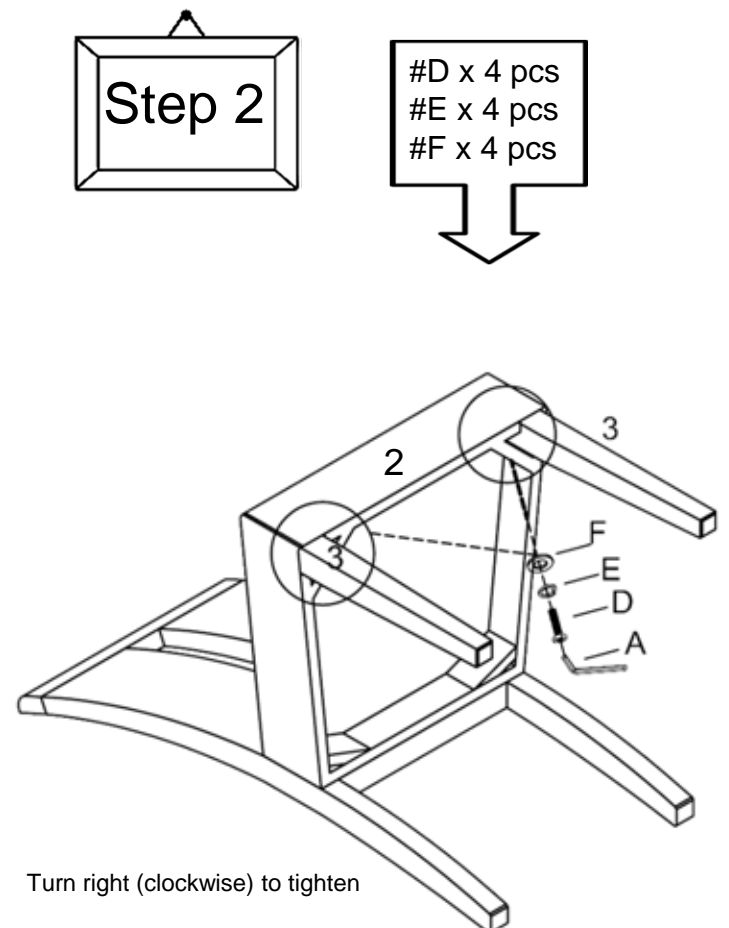

Assemble everything exactly the same for the second chair.