



ASSEMBLY INSTRUCTIONS COASTER FINE FURNITURE



Fine Furniture for every stage of life

205110Q(B1&B2) Queen Bed

ITEM: 205110Q(B1&B2)



ASSEMBLY INSTRUCTIONS

ASSEMBLY TIPS:

1. Remove hardware from box and sort by size.
2. Please check to see that all hardware and parts are present prior to start of assembly.
3. Please follow attached instructions in the same sequence as numbered to assure fast & easy assembly.



WARNING!

1. Don't attempt to repair or modify parts that are broken or defective. Please contact the store immediately.
2. This product is for home use only and not intended for commercial establishments.



ASSEMBLY TIME

20 MINUTES

PARTS IDENTIFICATION

B1 (BOX 1)

A HEADBOARD PANEL

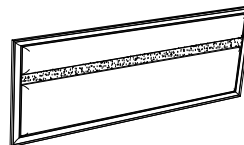

1PC

B FOOTBOARD

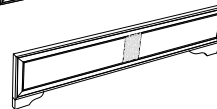

1PC

C LEFT HEADBOARD LEG



1PC

D RIGHT HEADBOARD LEG



1PC

E BED SLAT



4PCS

F BED SLAT SUPPORT WITH LEVELER



4PCS

B2 (BOX 2)

G BED RAIL

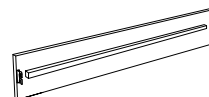

2PCS

HB

205110Q(B1) FROM BOX 1
HEADBOARD COMPLETE

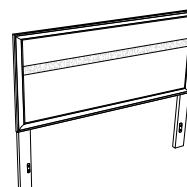

1PC

B

205110Q(B1) FROM BOX 1
FOOTBOARD

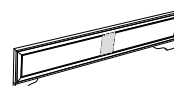

1PC

ITEM:205110Q(B1&B2)



ASSEMBLY INSTRUCTIONS

ASSEMBLY TIPS:

1. Remove hardware from box and sort by size.
2. Please check to see that all hardware and parts are present prior to start of assembly.
3. Please follow attached instructions in the same sequence as numbered to assure fast & easy assembly.







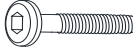

WARNING!

1. Don't attempt to repair or modify parts that are broken or defective. Please contact the store immediately.
2. This product is for home use only and not intended for commercial establishments.

HARDWARE IDENTIFICATION

Z-B1(BOX 1) - HARDWARE PACK IS LOCATED IN 205110Q(B1)

1	BOLT (M6 x 30mm - BLK)		6PCS
2	LOCK WASHER (1/4" - BLK)		6PCS
3	FLAT WASHER (1/4" x 13mm - BLK)		6PCS
4	SMALL ALLEN WRENCH (M4 x 65mm - BLK)		1PC
5	BIG ALLEN WRENCH (M5 x 65mm - BLK)		1PC
6	FLAT HEAD SCREW (M4 x 32mm - RBW)		8PCS

NOTE:

Phillips head screw driver is required in the assembly process; however, manufacturer does not provide this item.

ITEM: **205110Q(B1&B2)**



ASSEMBLY INSTRUCTIONS

STEP 1

Note : Please put item on soft surface.

Please take note of the marking sticker (L&R) on the leg.

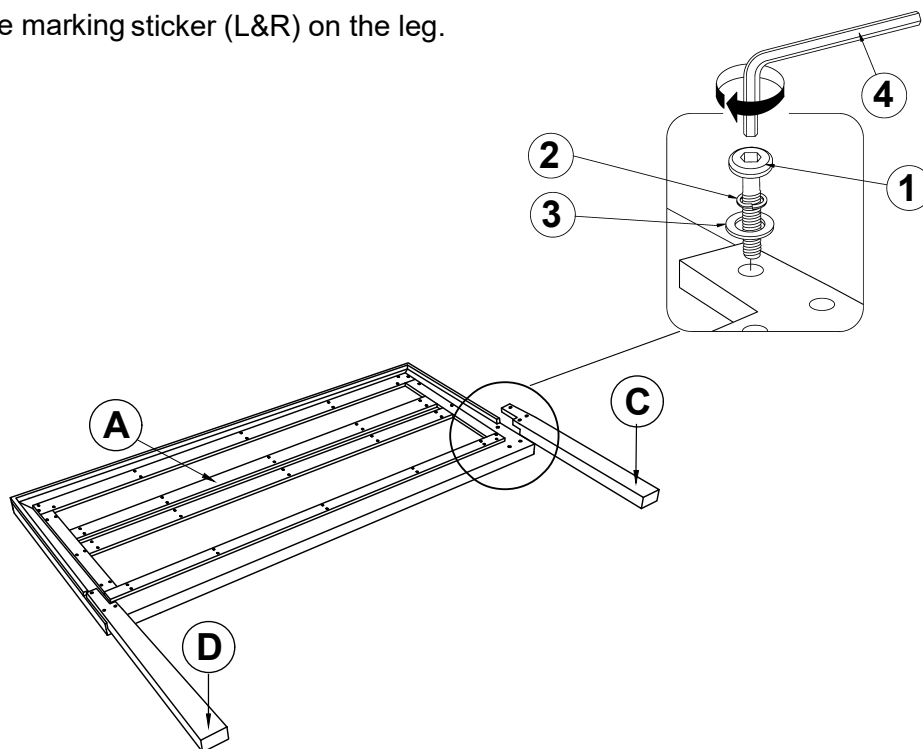

****BACK VIEW****

STEP 2

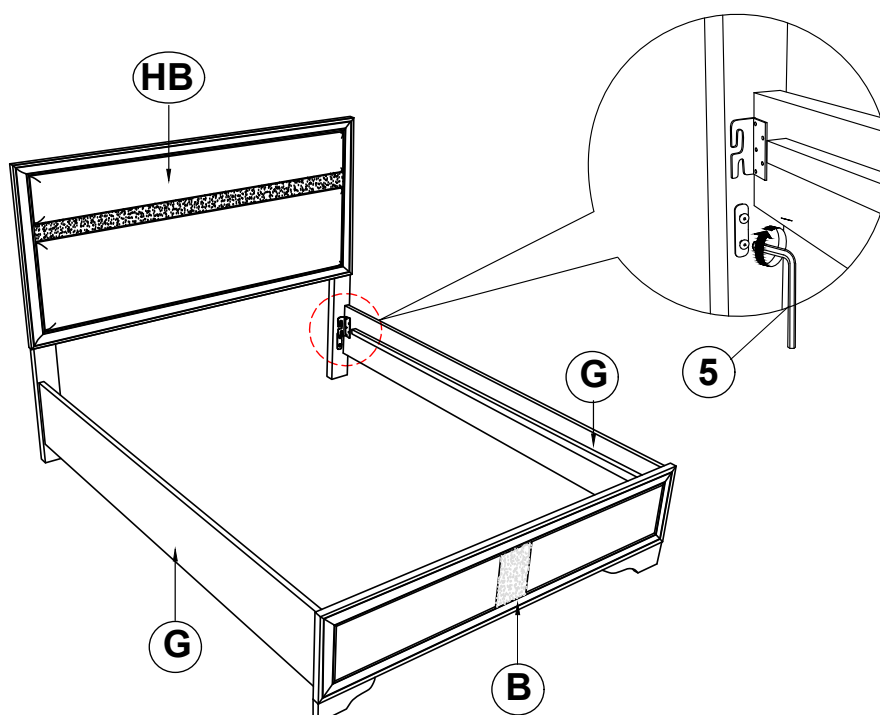

ITEM: **205110Q(B1&B2)**



ASSEMBLY INSTRUCTIONS

STEP 3

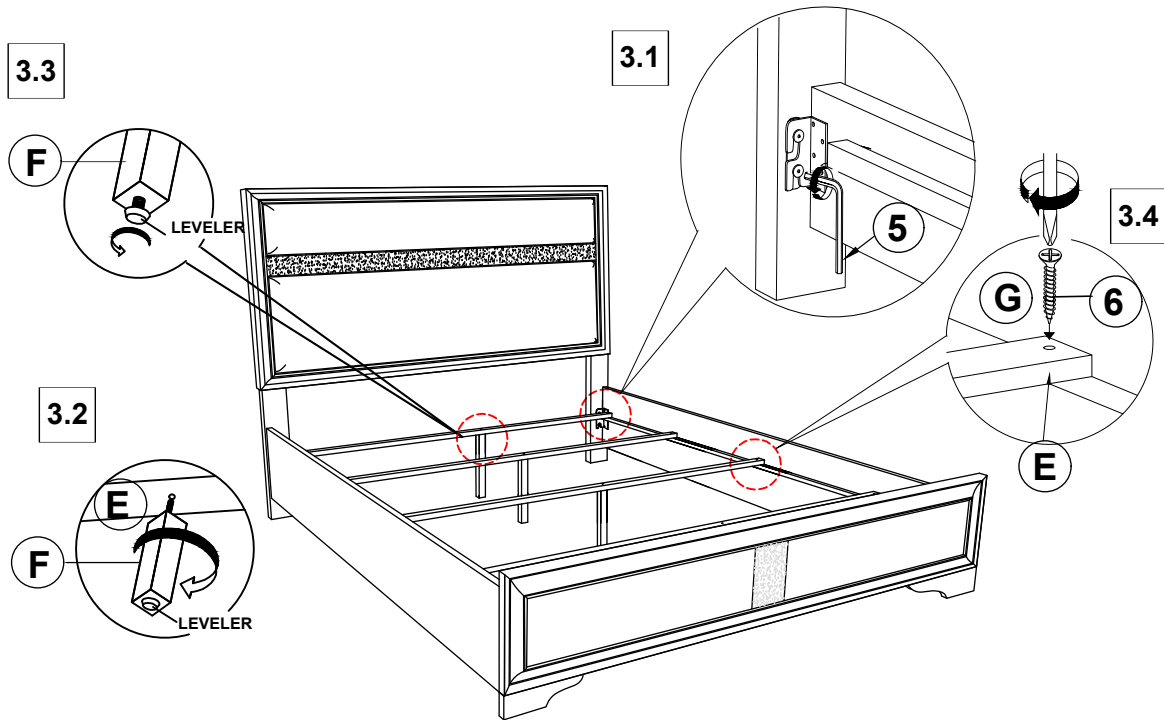

STEP 4
COMPLETE

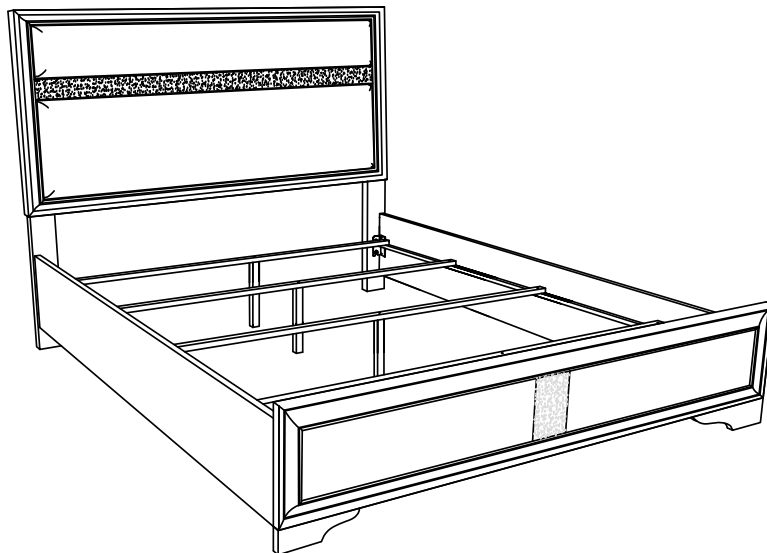

ASSEMBLY INSTRUCTIONS
COASTER FINE FURNITURE



Fine Furniture for every stage of life

205112
Nightstand

ITEM: **205112**

ASSEMBLY INSTRUCTIONS

ASSEMBLY TIPS:

1. Remove hardware from box and sort by size.
2. Please check to see that all hardware and parts are present prior to start of assembly.
3. Please follow attached instructions in the same sequence as numbered to assure fast & easy assembly.



WARNING!

1. Don't attempt to repair or modify parts that are broken or defective. Please contact the store immediately.
2. This product is for home use only and not intended for commercial establishments.



ASSEMBLY TIME

5 MINUTES

PARTS IDENTIFICATION

A NIGHTSTAND

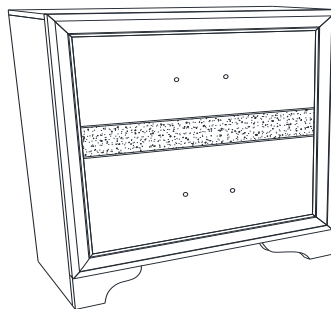

1PC

NOTE:

Phillips head screw driver is required in the assembly process; however, manufacturer does not provide this item.

STEP 1

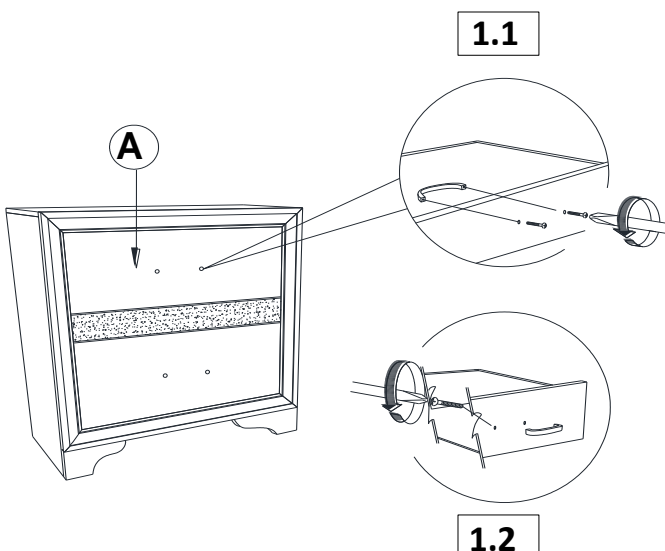

STEP 2 **COMPLETE**

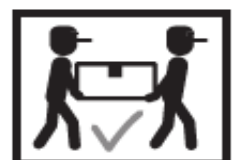
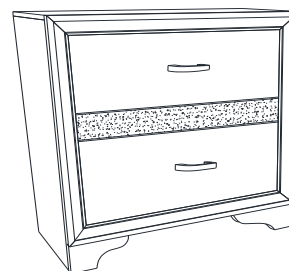

ITEM: **205112**



Inner Size of Drawer A: 18.00"W X 12.50"D X 4.00"H X 0.25"T

Inner Size of Drawer B: 18.00"W X 12.50"D X 1.25"H X 0.25"T

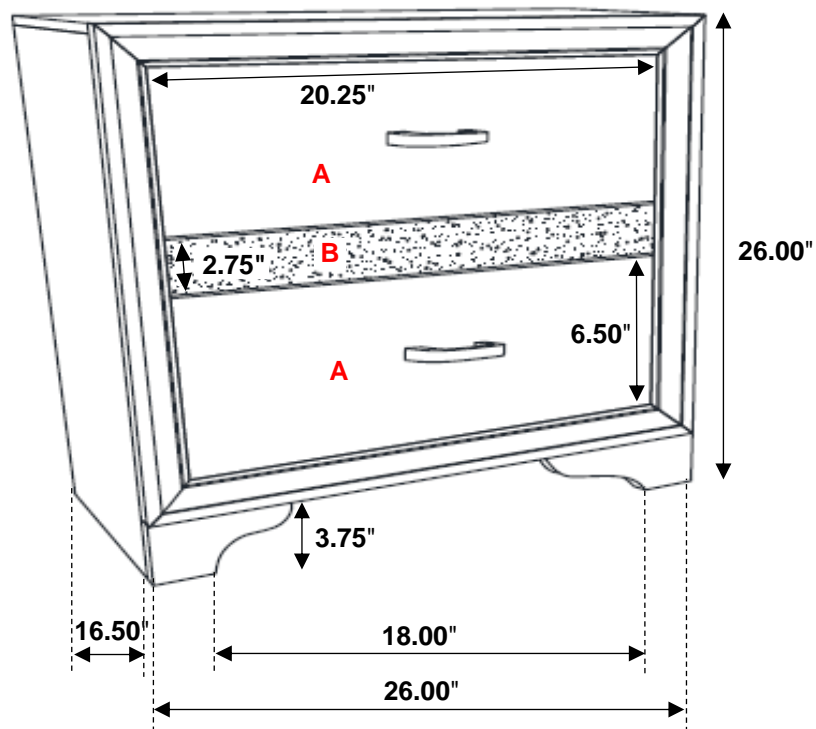

Note: Dimension tolerance $\pm 5\%$

ASSEMBLY INSTRUCTIONS
COASTER FINE FURNITURE



Fine Furniture for every stage of life

205113
Dresser

ITEM: **205113**



ASSEMBLY INSTRUCTIONS

ASSEMBLY TIPS:

1. Remove hardware from box and sort by size.
2. Please check to see that all hardware and parts are present prior to start of assembly.
3. Please follow attached instructions in the same sequence as numbered to assure fast & easy assembly.



WARNING!

1. Don't attempt to repair or modify parts that are broken or defective. Please contact the store immediately.
2. This product is for home use only and not intended for commercial establishments.



ASSEMBLY TIME

5 MINUTES

PARTS IDENTIFICATION

A DRESSER

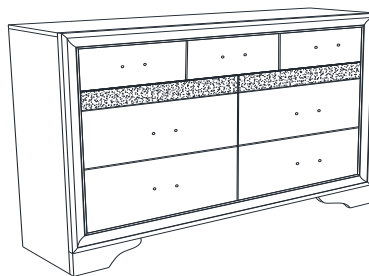

1PC

NOTE:

Phillips head screw driver is required in the assembly process; however, manufacturer does not provide this item.

STEP 1

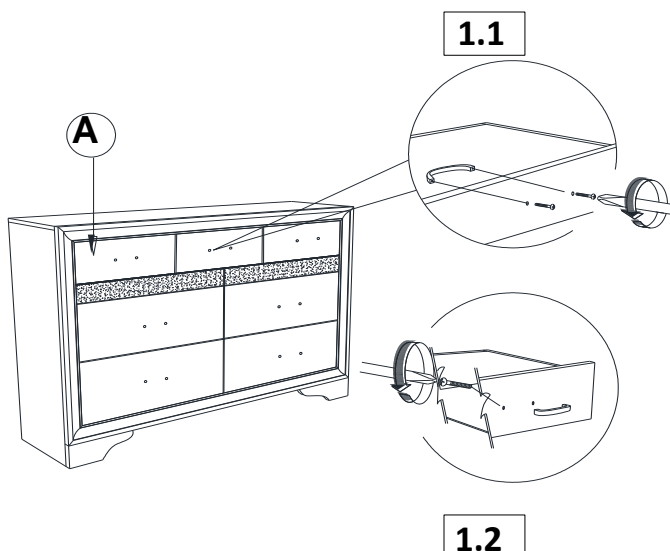

STEP 2 COMPLETE

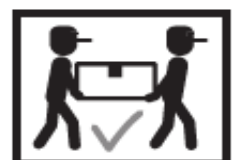

ITEM: **205113**



Inner Size of Drawer A: 17.00"W X 12.50"D X 5.00"H X 0.25"T
Inner Size of Drawer B: 26.00"W X 12.50"D X 1.25"H X 0.25"T
Inner Size of Drawer C: 26.75" W X 12.50"D X 6.00"H X 0.25"T

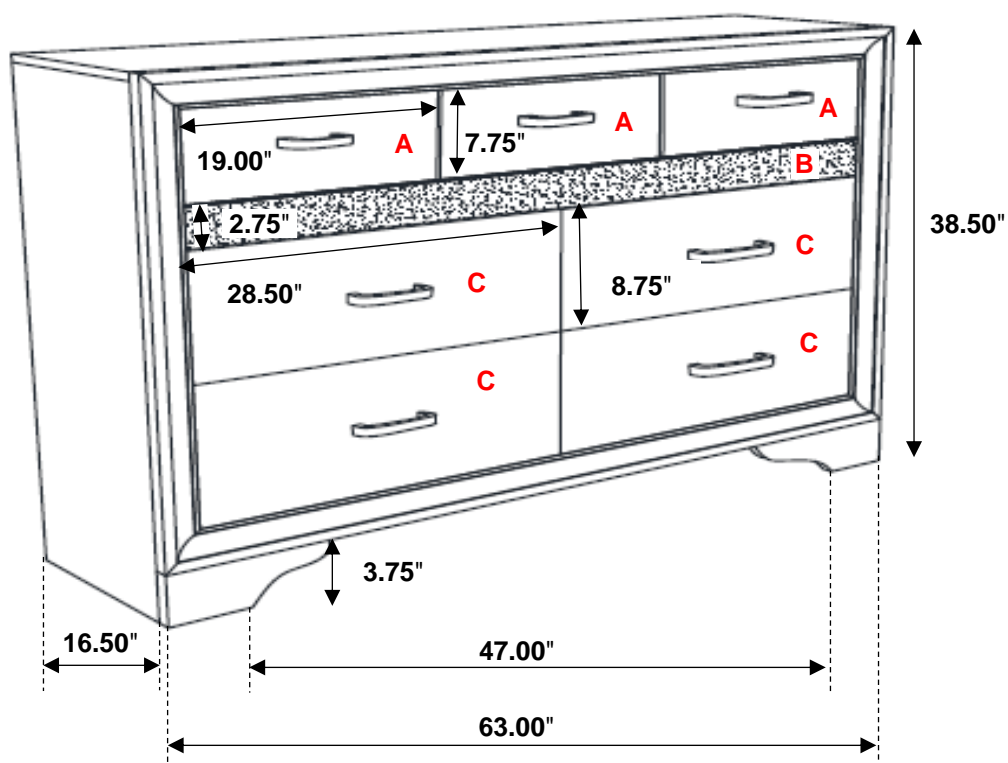

Note: Dimension tolerance $\pm 5\%$

ASSEMBLY INSTRUCTIONS
COASTER FINE FURNITURE



Fine Furniture for every stage of life

205114
Mirror

ITEM: 205114



ASSEMBLY INSTRUCTIONS

ASSEMBLY TIPS:

1. Remove hardware from box and sort by size.
2. Please check to see that all hardware and parts are present prior to start of assembly.
3. Please follow attached instructions in the same sequence as numbered to assure fast & easy assembly.



WARNING!

1. Don't attempt to repair or modify parts that are broken or defective. Please contact the store immediately.
2. This product is for home use only and not intended for commercial establishments.



ASSEMBLY TIME

10 MINUTES

PARTS IDENTIFICATION

A	MIRROR		1PC	C	MIRROR SUPPORT (PACKED WITH MIRROR)		2PCS
B	DRESSER FROM BOX ITEM #205113		1PC				

HARDWARE IDENTIFICATION

1	SHORT BOLT (M6 x 35mm - BLK)		4PCS	4	FLAT WASHER (1/4" ID x 19mm - BLK)		8PCS
2	LONG BOLT (M6 x 40mm - BLK)		4PCS	5	ALLEN WRENCH (M4 x 60MM - BLK)		1PC
3	LOCK WASHER (1/4" - BLK)		8PCS				

ITEM: **205114**



ASSEMBLY INSTRUCTIONS

STEP 1

ARROW MARKING FACE UPWARD

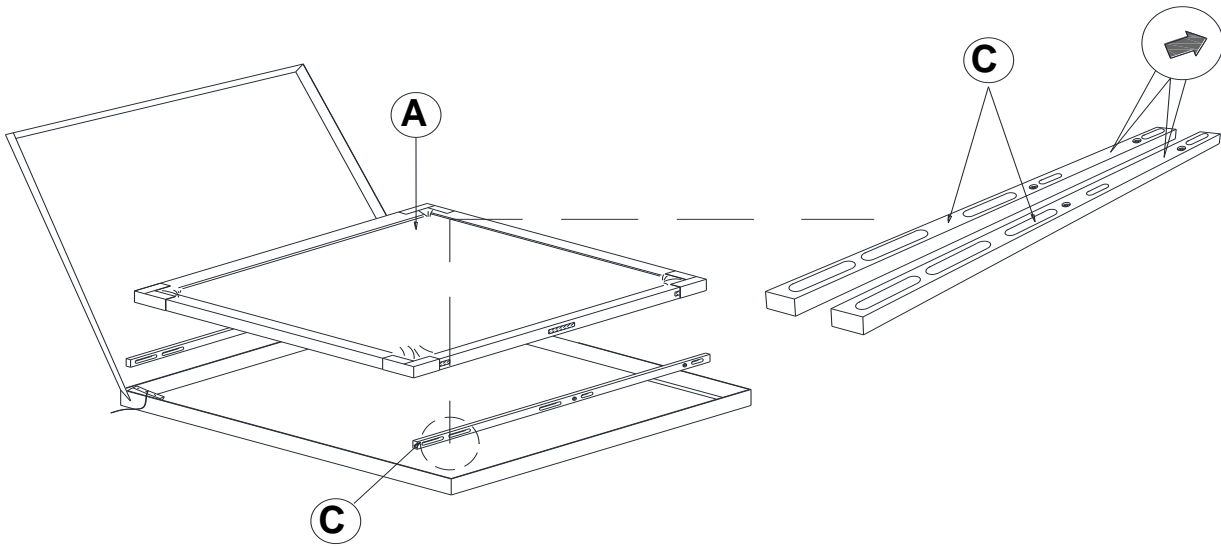

STEP 2

ARROW MARKING FACE UPWARD

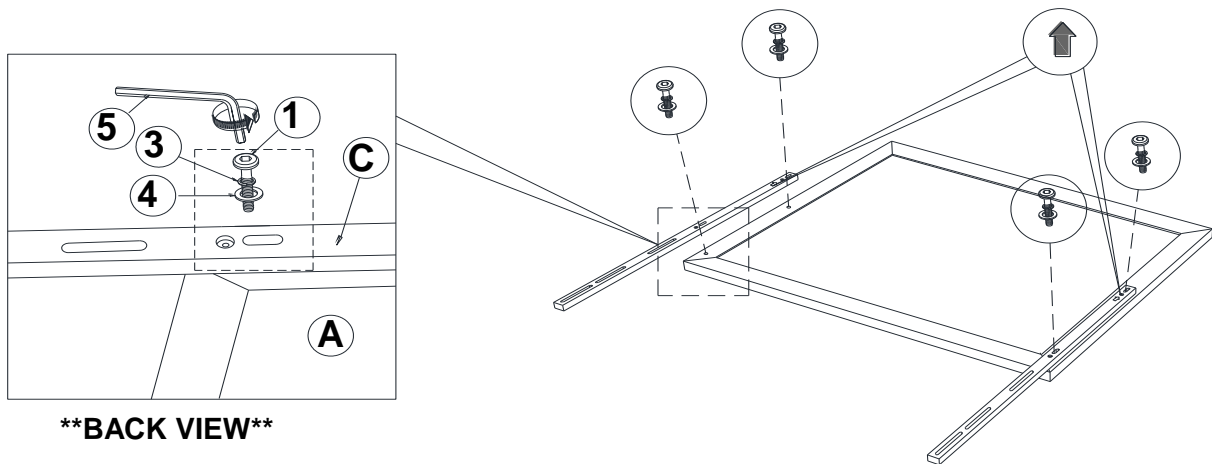

****BACK VIEW****

ITEM: **205114**



ASSEMBLY INSTRUCTIONS

STEP 3

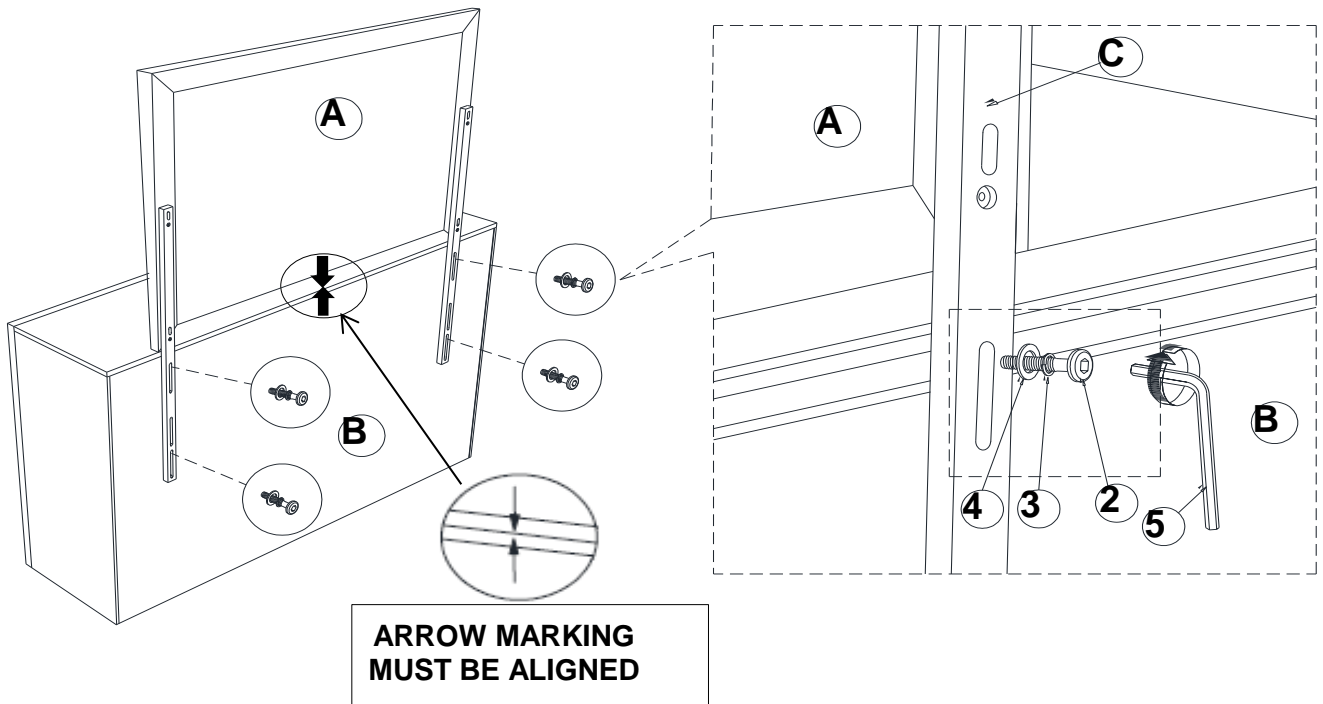

STEP 4 **COMPLETE**



ITEM: 205114

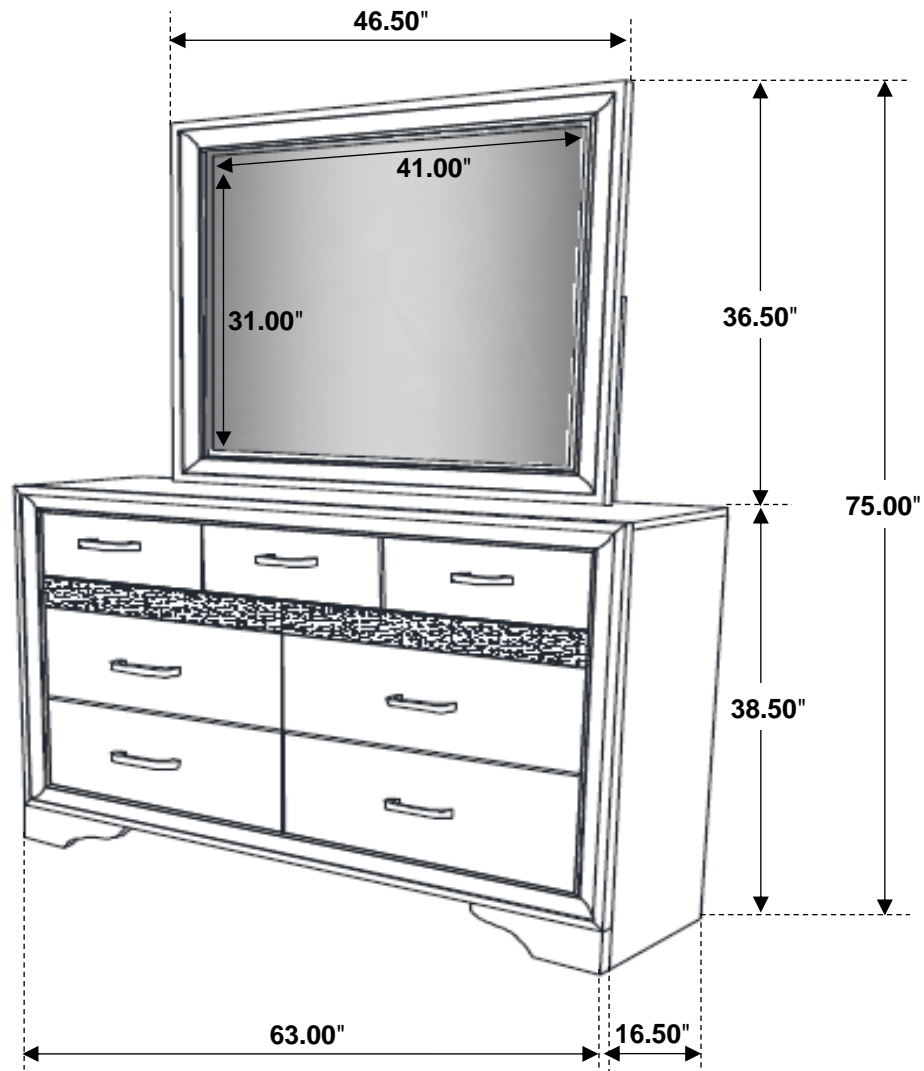

Note: Dimension tolerance $\pm 5\%$

ASSEMBLY INSTRUCTIONS
COASTER FINE FURNITURE



Fine Furniture for every stage of life

205115
Chest

ITEM: **205115**



ASSEMBLY INSTRUCTIONS

ASSEMBLY TIPS:

1. Remove hardware from box and sort by size.
2. Please check to see that all hardware and parts are present prior to start of assembly.
3. Please follow attached instructions in the same sequence as numbered to assure fast & easy assembly.



WARNING!

1. Don't attempt to repair or modify parts that are broken or defective. Please contact the store immediately.
2. This product is for home use only and not intended for commercial establishments.



ASSEMBLY TIME

5 MINUTES

PARTS IDENTIFICATION

A

CHEST



1PC

NOTE:

Phillips head screw driver is required in the assembly process; however, manufacturer does not provide this item.

STEP 1

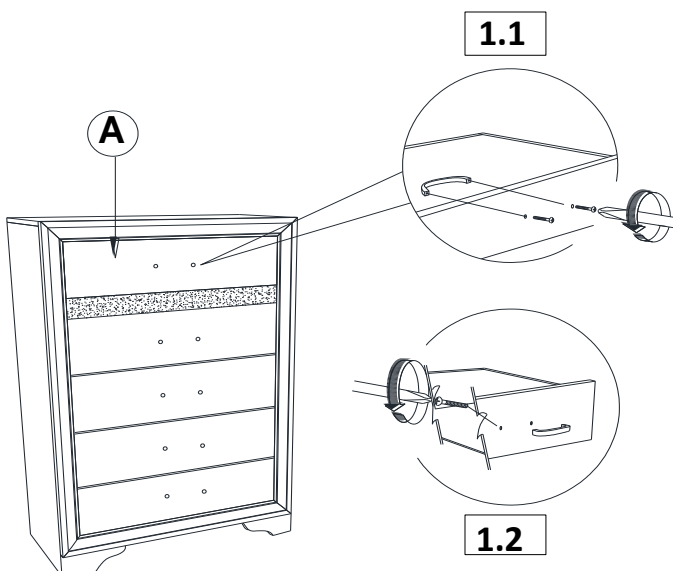

STEP 2 COMPLETE

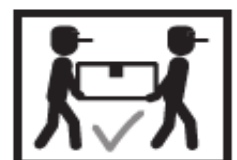

ITEM: **205115**



Inner Size of Drawer A: 26.50"W X 12.50"D X 4.00"H X 0.25"T
Inner Size of Drawer B: 25.50"W X 12.50"D X 1.18"H X 0.25"T
Inner Size of Drawer C: 26.50"W X 12.50"D X 5.00"H X 0.25"T

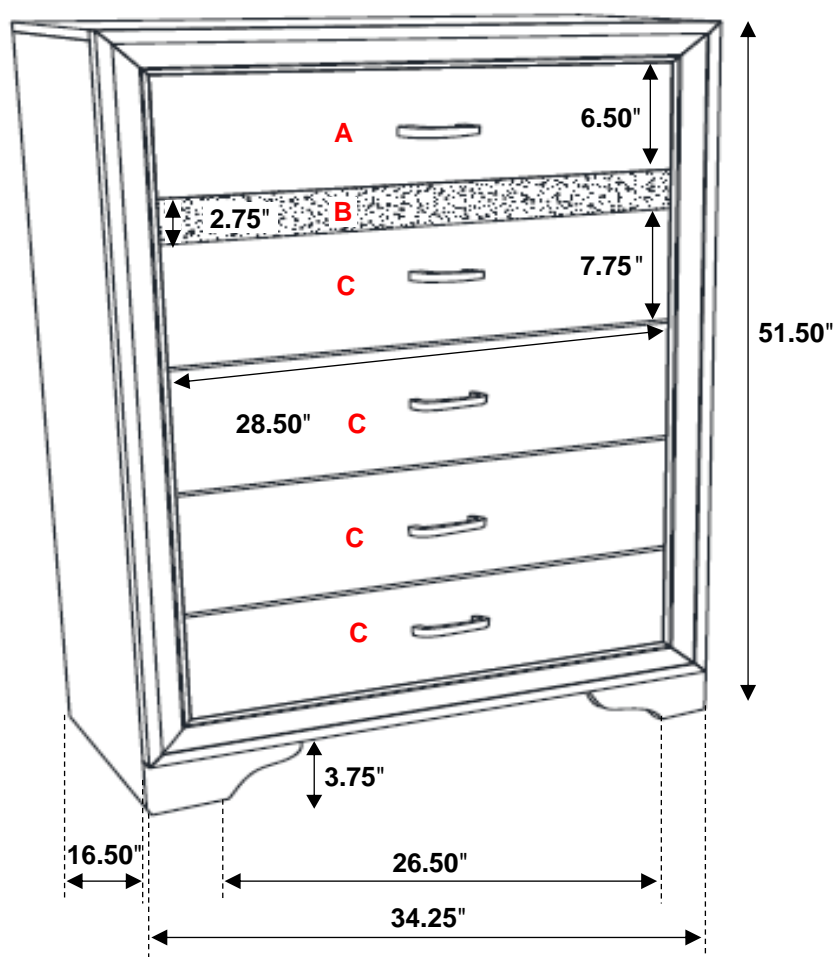

Note: Dimension tolerance $\pm 5\%$