

Assembly Instructions

DAY BED

CAUTION: You must read this before you proceed

Please look in Seat Panel for hardware packs

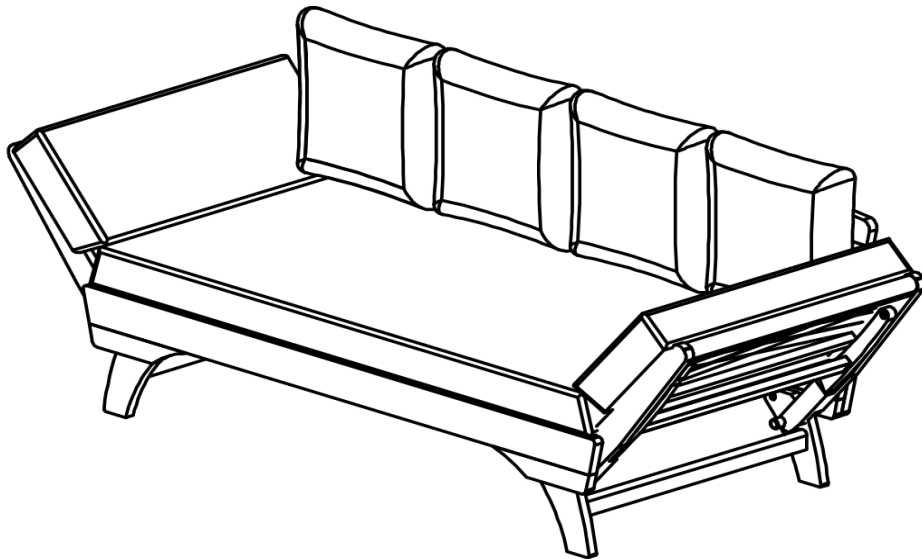



CAUTION: This Daybed is NOT a TOY.

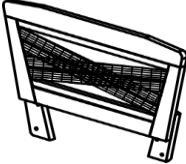
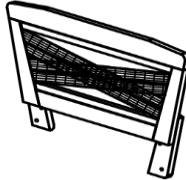
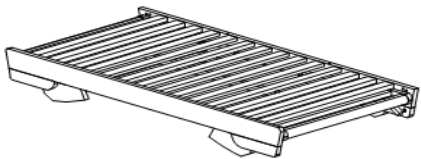
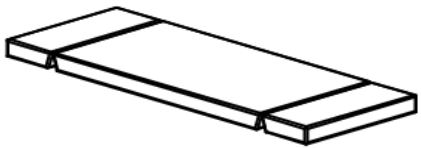

Keep your child / children at bay in the process of assembly.

For turning the Daybed and to prevent damage to the Daybed, 02 persons may be needed to execute this action.

Parts List

Label	Picture	Description	Qty
A		Left Backrest Panel	1
B		Right Backrest Panel	1
C		Seat Panel with Pre-fixed folding Leg	1
D		Seat Cushion	1
E		Back Pillow	4

Hardware

Label	Picture	Description	Qty
①		Allen Key	2
②		Bolt (M6*35mm)	9

Assembly Preparation

Before Beginning Assembly:

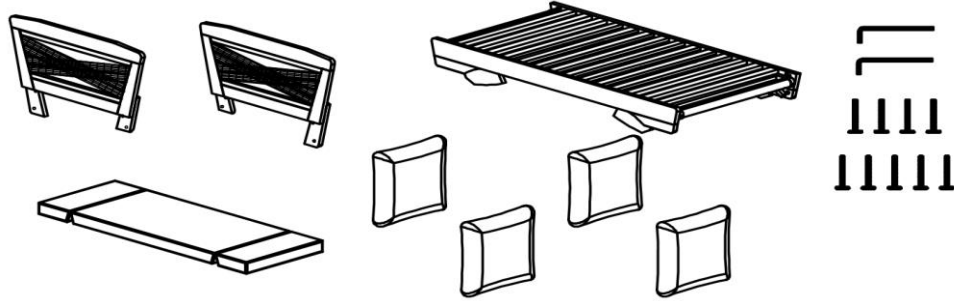

- Read instructions, cover to cover-



- Have 2 adults on hand for assembly-



- Do not assemble on flooring or carpet-



- Assemble on a clean non-marring surface (packing foam)-



- Save all packaging until finished-

Assembly Steps

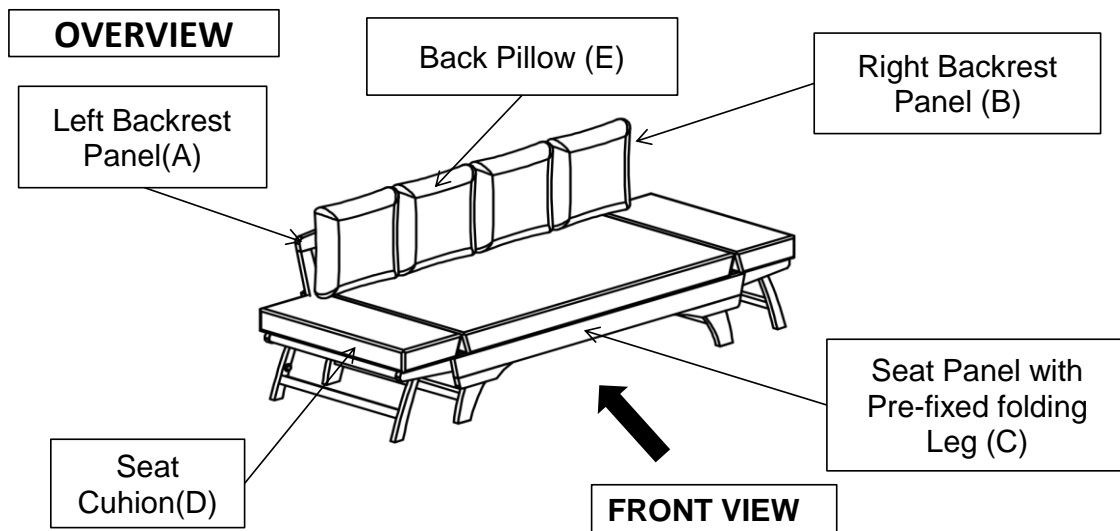

This Day Bed has multiple parts and may require up to some 30 minutes to assemble. To give you an overview of the Day Bed, the above picture is to help you put the various parts into perspective. Please read through the instructions here below to familiarise yourself with the parts and steps before assembly.

Step 1

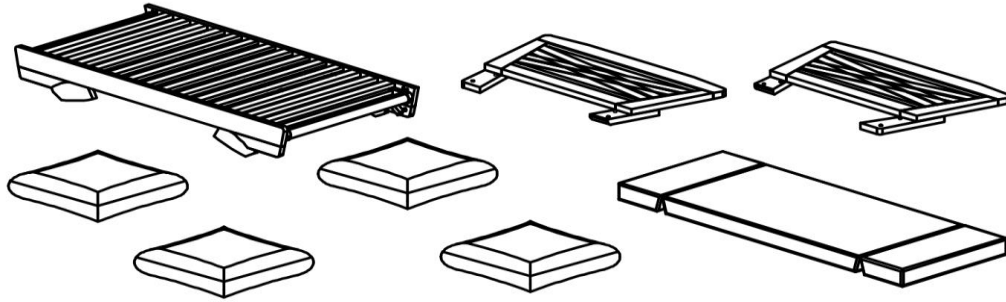

Unpack and place all parts on a clean, non-marring surface.

Step 2

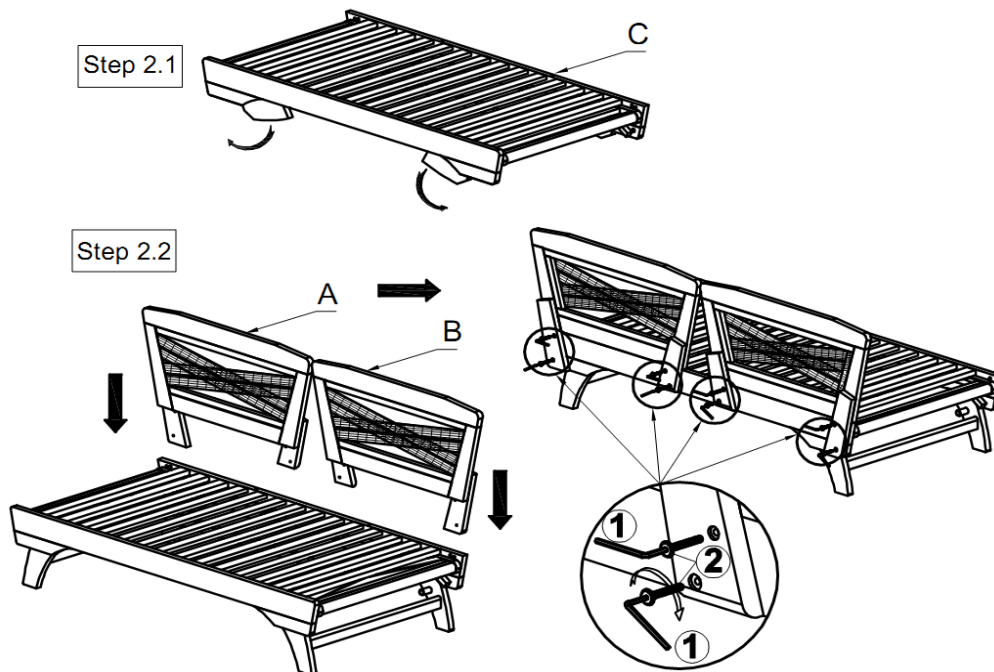

2.1) Open the Folding Leg Panels prefixed under the Seat Panel(C) as shown in above picture.

2.2) Attach the Left Backrest Panel(A) and the Right Backrest Panel(B) to the Seat Panel with the Pre-fixed folding Leg(C) using 8 Bolts(②) and the Allen Key(①) at the designated points shown in the picture above.

Do not fully tighten the Bolts and Screws.

This Daybed has multiple functions.

Belows are some steps to help you know how to use this Daybed for your purpose. This Daybed can only be used on a flat, level surface.

Function 1: A Bed

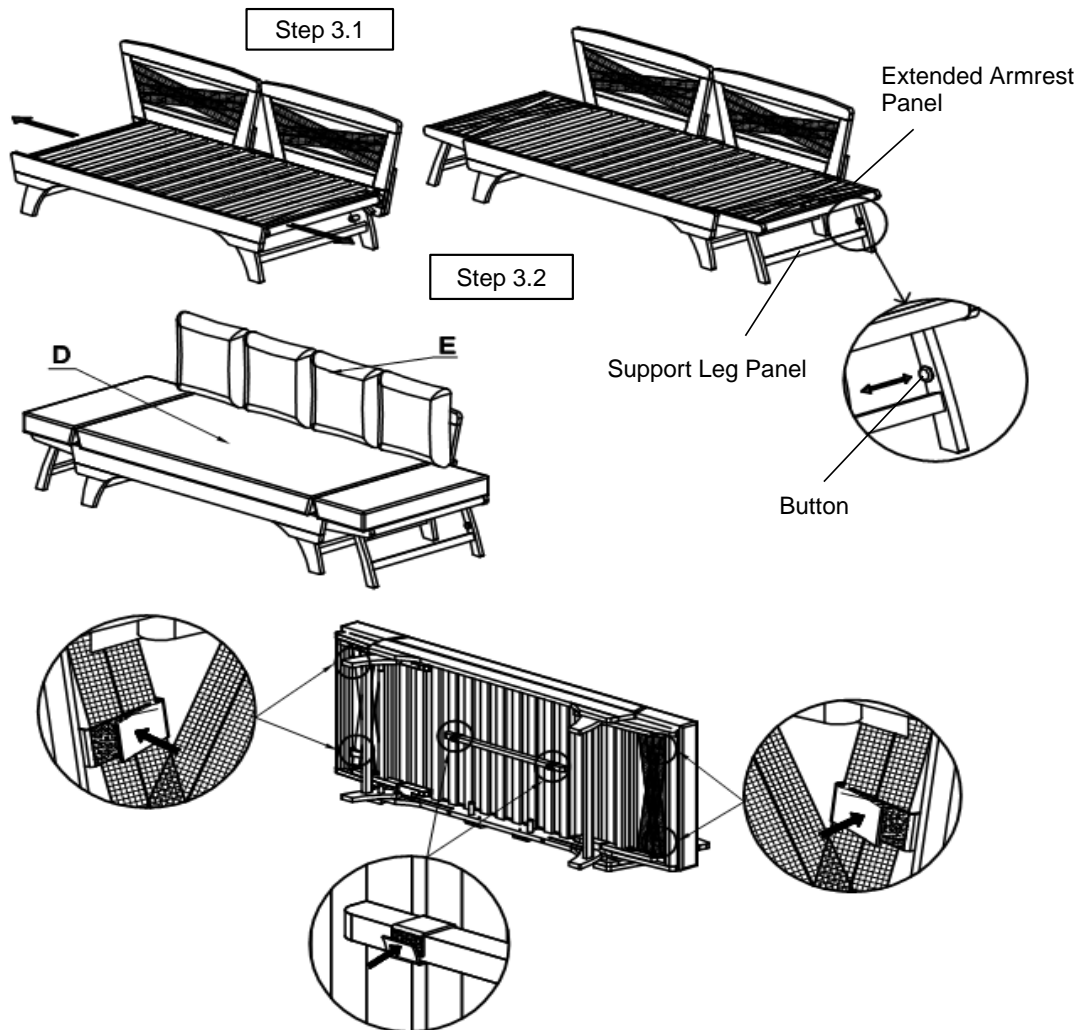

To use this Daybed as a bed, follow these instructions:

3.1) Retract the Extended Armrest under the Seat Panel(B) to the maximum level, then raise the Amrest slightly. Next, pull the Buttons to open the Support Leg Panels as shown on the picture. Finally, pull the Extended Armrest until its Side Rail is flushed with the slats on the Seat Panel(B).

3.2) Place the Seat Cushion(C) and the Back Pillows(D) onto the Daybed. Then, with the help of an adult partner, tie the velcro straps of the Back Cushion(C) to the Backrest Panel(A) and the Seat Panel(C) as shown in picture above.

Function 2: A Sunlounger

Step 4.1

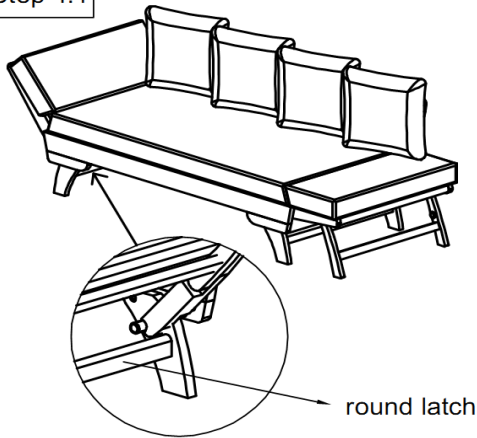

Step 4.2

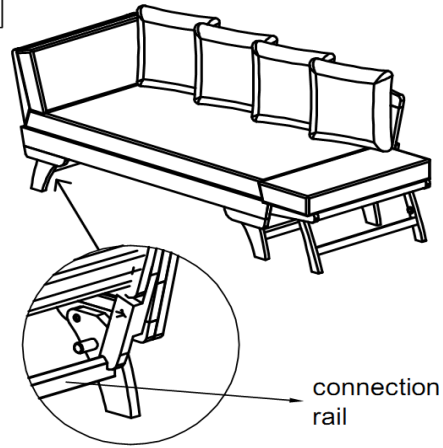

This Daybed can also be used as a Sunlounger with an Adjustable Armrest. Pull the armrest, close the Leg Panels and lock the Button.

4.1) Raise 1 Amrest halfway to gain the first level of the Armrest.

At this level, the groove hole in the armrest will match with the round latch as shown in the picture.

4.2) Release the Armrest and raise this section to maximum height.

The groove hole in the armrest will match with the connection rail.

Separate the Velcro on the Seat Panel cushion when changing the Armrest panel height.

Function 3: A Bench

Step 5.1

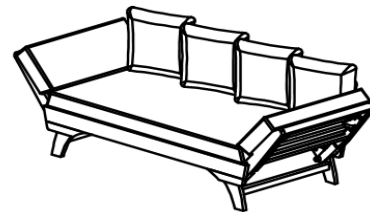
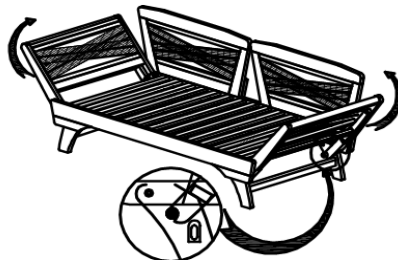



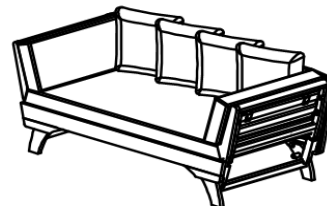
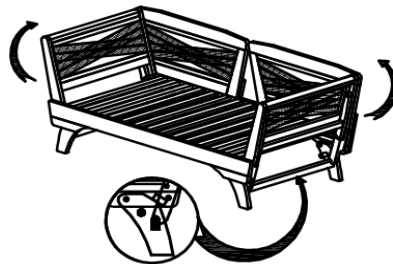





Step 5.2



To use the Daybed as a Bench, adjust the Armrest height the same way as Function 2, but for both sides.

Care & Maintenance

- ⊗  ● Do not put hot items directly on furniture surface
 - ⊗  ● Do not clean furniture with harsh cleansers or polish.
 - ✓  ● To obtain the longest lifespan of your outdoor products, minimizing exposure to direct sunlight is recommended.
 - ⊗  ● Children should not climb or jump on the furniture.
 - ⊗  ● Do not write on furniture without a padded barrier to protect the surface.
 - ✓  ● To obtain the longest lifespan of your outdoor products, avoid extended and lengthy exposure to rain, snow, and direct sunshine. Whenever possible cover the product and / or place under patio or awnings.
 - ⊗  ● Not for commercial use. For residential use only .
 - ⊗  ● Stains may be removed with mild soap solution and damp cloth.
 - ✓  ● Dust and pick-up spills using a clean, non colored lint-free cloth
-