

User's Manual

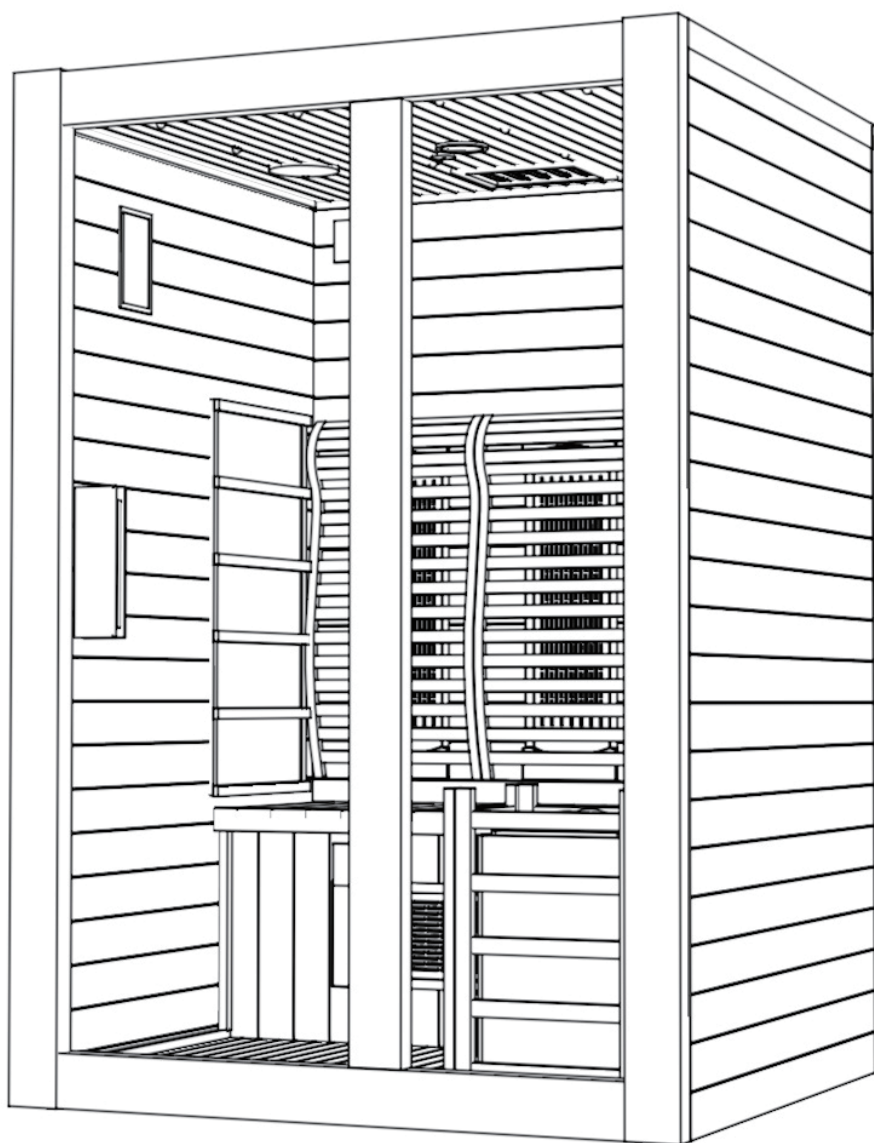

Contents

	Page
Sequences and contents of sauna assembly	
Electrical Requirements	- 3 -
Tools you need to prepare	- 3 -
Components of Sauna Room	- 4 -
Installation Instructions	- 5 -
1. Base assembly step	- 5 -
2. Back and side panels assembly step	- 5 -
3. Roof assembly step	- 7 -
4. Wiring steps for a 3.5KW sauna heater	- 8 -
5. Wiring steps for a 4.5KW/6.0KW sauna heater	- 9 -
6. Wiring steps for a 8.0KW sauna heater	-10-
7. Internal accessories assembly steps	-11-
Accessories	-12-
Control Panel Operation Instructions	-13-
Saunas and Contraindications	-16-
Warranty Policy	-18-

Electrical Requirements

Each sauna will require a dedicated circuit when plugged in an outlet according to the chart below. A dedicated circuit requires that no other appliance should share the outlet/circuit with the sauna. Failure to comply with this requirement may cause electrical interruption and diminished performance. It is recommended that a qualified electrician install your dedicated electrical wiring for proper sauna functionality and to avoid any potential electrical hazards. Please make sure the sauna is properly grounded. Serious injury may result if proper electrical requirements are not met.

Please follow all instructions carefully. Keep the sauna away from any potential hazards including any water source or liquids. Select a dry suitable location for the sauna installation. Do not expose the heater elements to any water source or liquids as it may cause electrical shock. Should you have any questions, please do not hesitate to contact the supplier.

Please read the following directions carefully. The sauna installation requires a minimum of 2 people. You should not try to install the sauna on your own as damage will easily occur.

Tools you need to prepare

Power Drill x 1	Herringbone ladder X1
	

Indoor Steam Sauna				
Product Model	Heater	Voltage	Amp	Plug
Hybrid 1	Harvia Stove 3.5KW	220V	16A	NEMA 6-20p
Hybrid 2	Harvia Stove 4.5KW	220V	20A	NEMA 6-20p
Hybrid 3	Harvia Stove 4.5KW	220V	20A	NEMA 6-20p
Hybrid 4	Harvia Stove 6.0KW	220V	30A	NEMA L6 - 30p

Components of Sauna Room

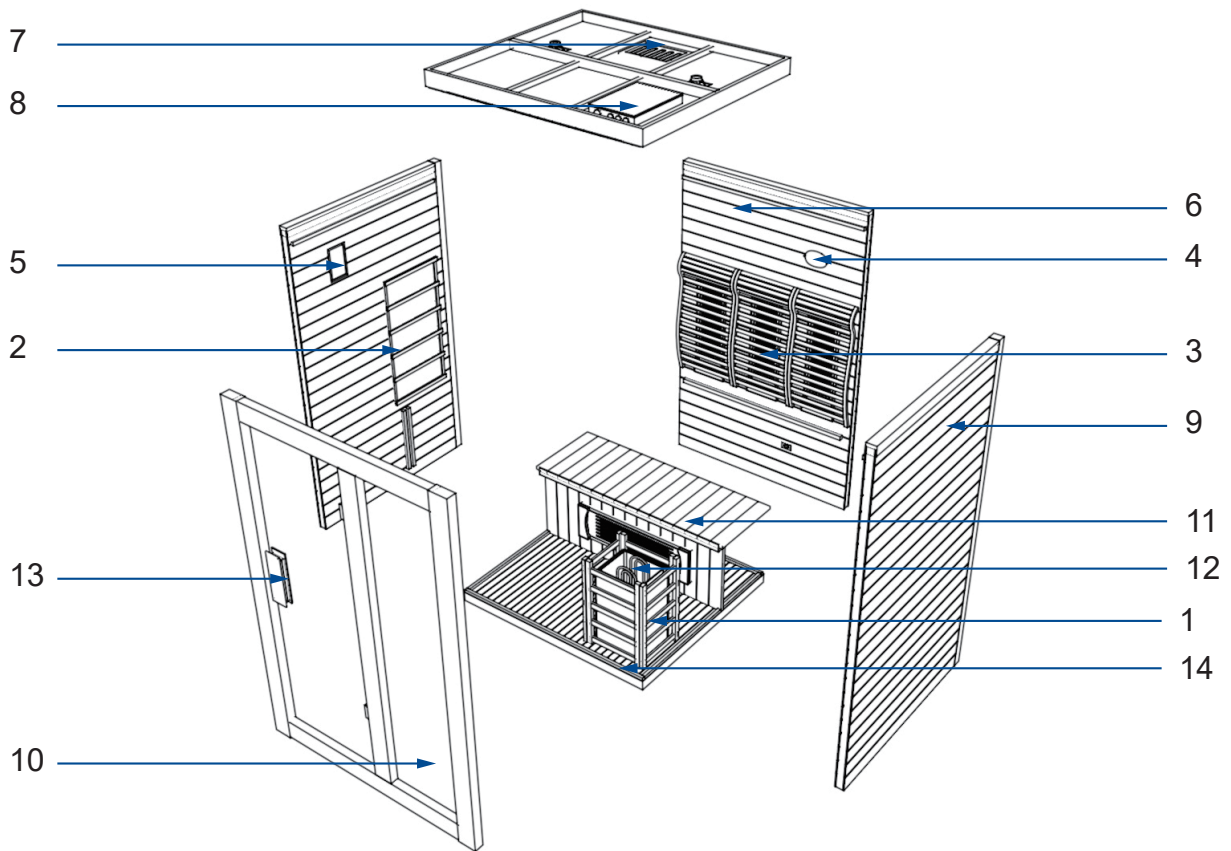

NO.	Part Name	NO.	Part Name
1	Sauna stove frame	8	Electrical control system
2	Left side panel	9	Right side panel
3	Backrest	10	Front panel
4	Oxygen bar	11	Bench
5	Control panel	12	Electric sauna stove
6	Back panel	13	Wooden handle
7	Breathable skylight	14	Bottom panel

Installation Instructions

1. Base assembly step:

① Place floor plank face up on the ground.

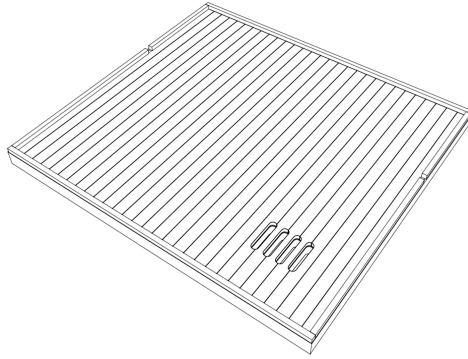

2. Back and side panels assembly step:

Steps to use the buckle.

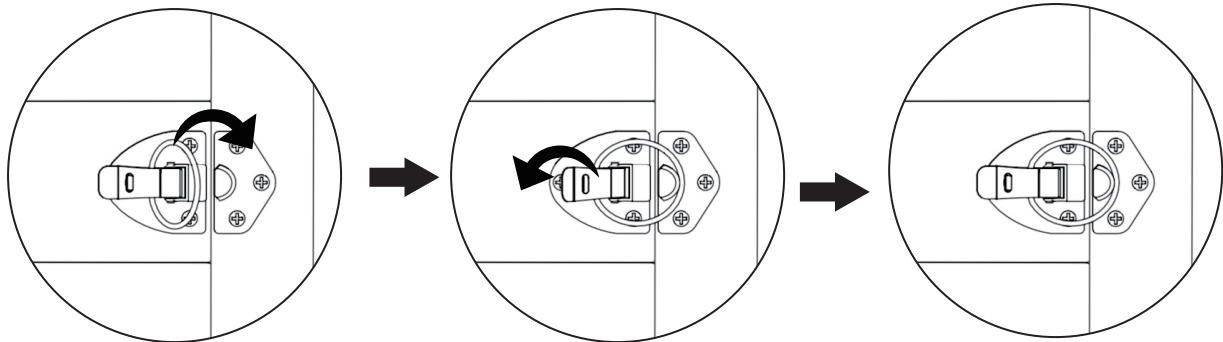

① Place the back panel. (Please note that someone needs to hold the back panel here)

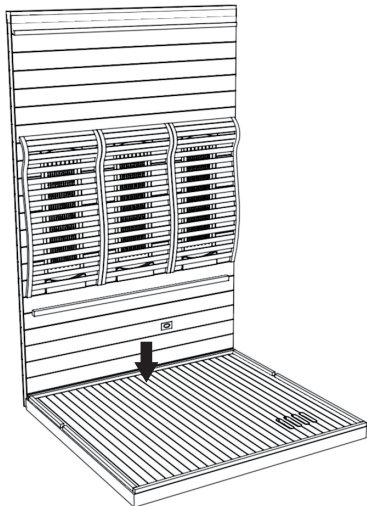

② Place the side panel, fasten the buckles to secure the back panel and side panel.

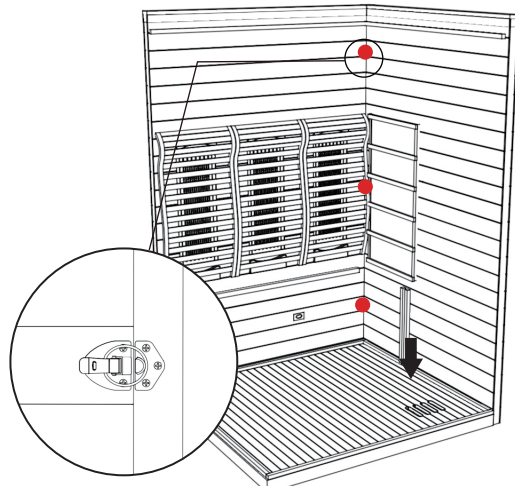

③ Place the side panel on the other side , fasten the buckles to secure the back panel and side panel.

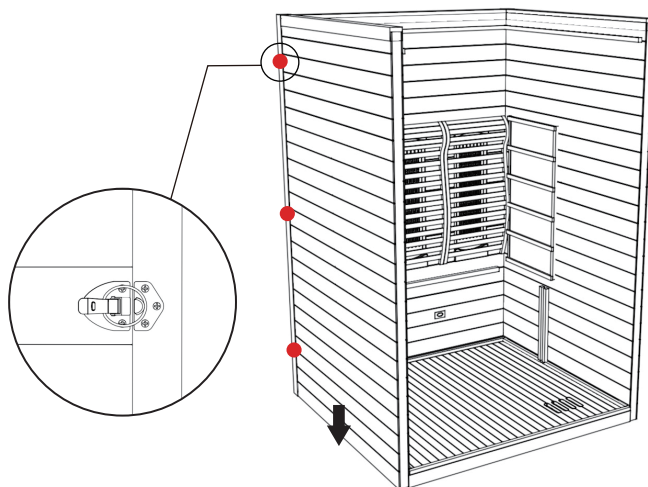

④ Install the bench, and connect the plug of the heating element.

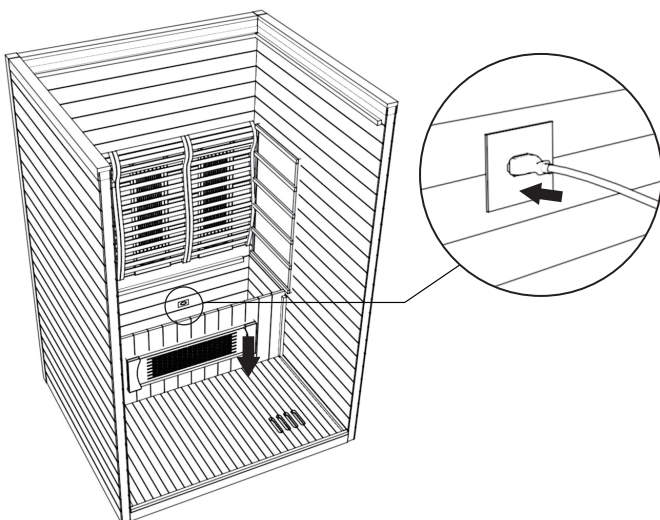

⑤ Install the seat board of the bench.

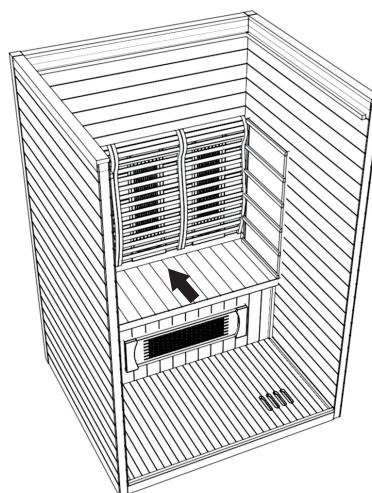

⑥ Install the front panel, fasten the buckles to secure the front panel and side panels.

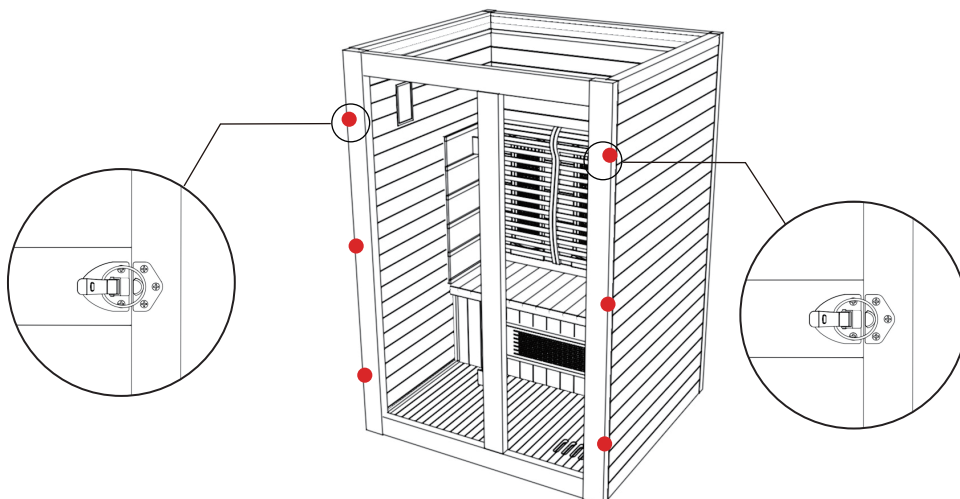

3. Roof assembly step:

① Pass the wires of the side wall through the holes reserved on the top wall, and then place the top wall in the correct position.

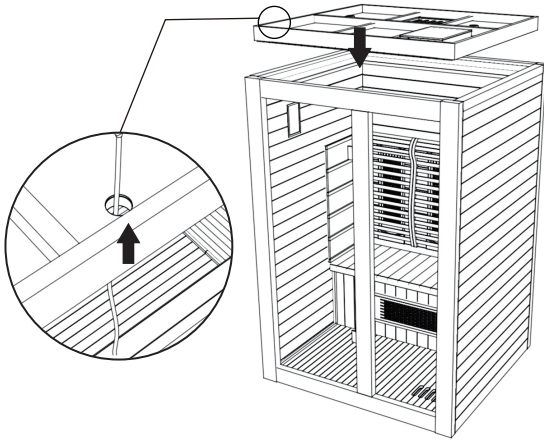

② Connect all the corresponding sockets and plugs for the letters and the corresponding sockets and plugs for the shapes.

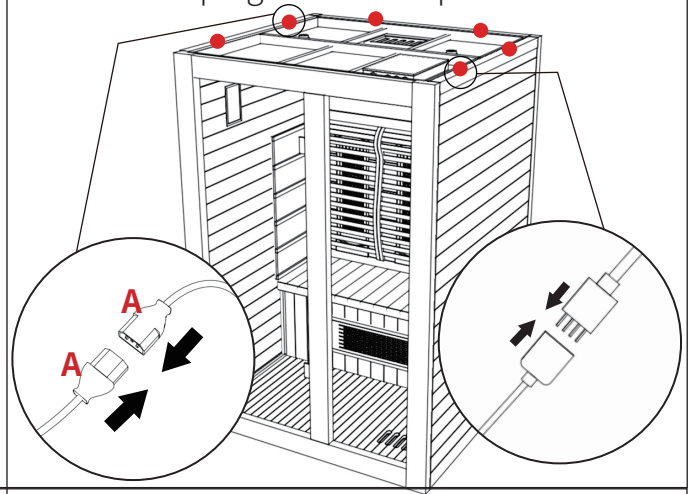

③ Open the cover of the electrical box.

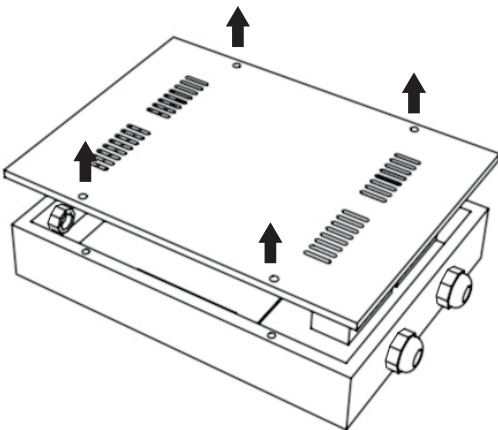

④ Connect the wires labeled "L", "N", and "E" to the terminals labeled "L", "N", and "E". (The wiring procedure applies to 3.5KW, 4.5KW and 6.0KW heaters.)

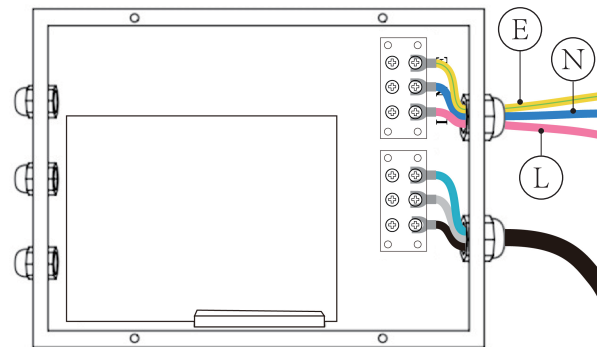

⑤ Connect the wires labeled "L1", "L2", "L3", "N", and "E" to the terminals labeled "L1", "L2", "L3", "N", and "E". (The wiring procedure applies to 8.0KW heaters.)

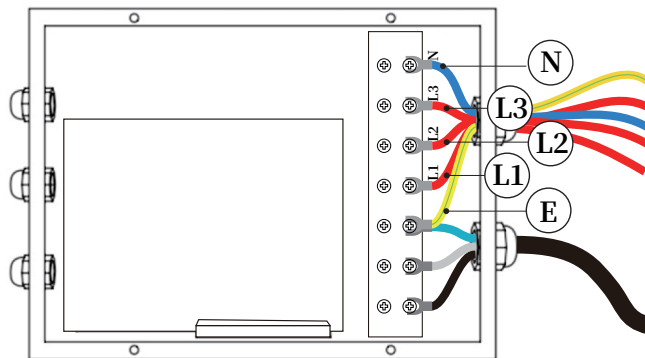

4. Steps for connecting the sauna stove's electrical wires (The wiring procedure applies to 3.5KW heaters.)

① Open the Harvia heater side panel.

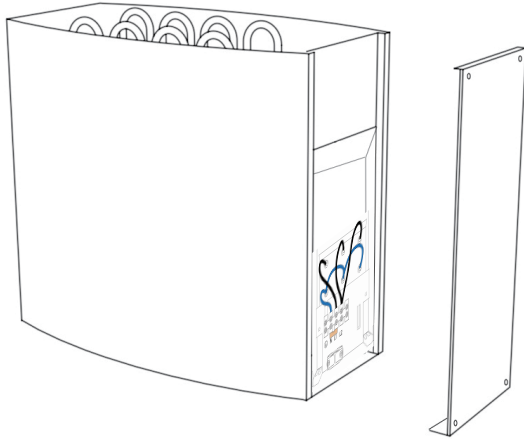

② You can see there is a copper sheet on the terminal.

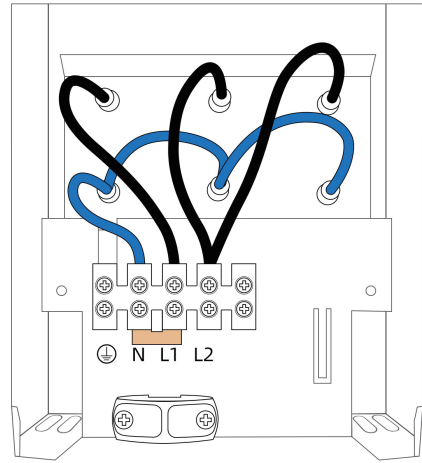

③ Remove the copper sheet from the terminal.

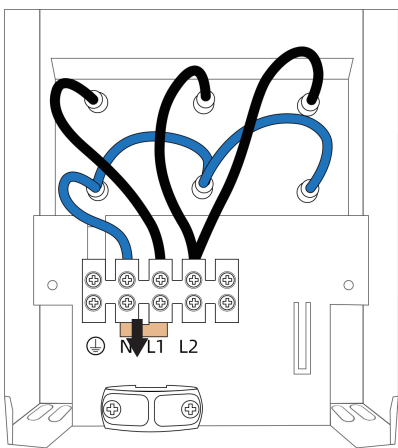

④ Put it on the two terminals marked L1 and L2.

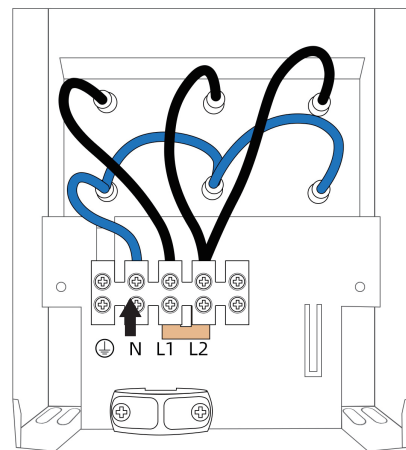

⑤ Connect the red wire marked with "L" to the terminal with black cable connection marked L1 below. Connect the blue wire marked with "N" to the terminal with blue cable connection marked N below. Connect the green/yellow wire marked with "E" to the terminal without cable connection.

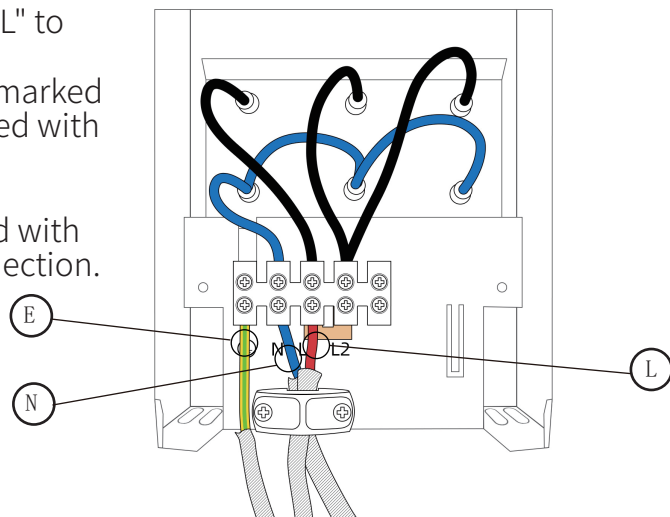

5.Steps for connecting the sauna stove's electrical wires (The wiring procedure applies to 4.5KW and 6.0KW heaters.)

① Open the Harvia heater side panel.

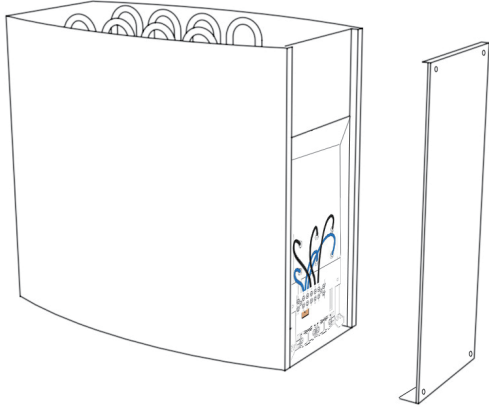

② Remove the three copper sheets from the terminal (3 copper sheets are stacked together).

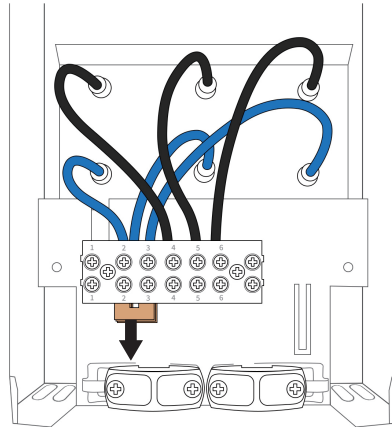

③ Take one and place it on the 2 terminals that has the blue cable attached to them.

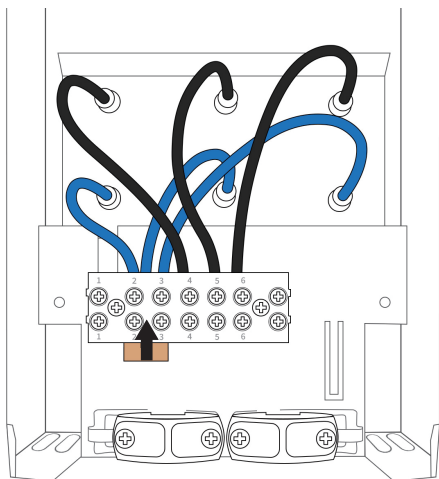

④ Arrange the other two in a "W" shape and place them on the 3 terminals that has the black cable attached to them.

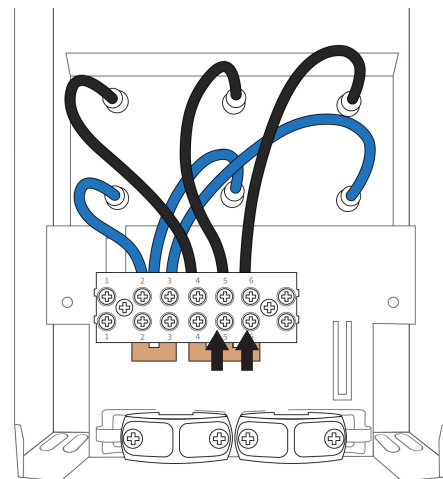

⑤ Connect the wire marked with "L" to the terminal with black cable connection (select 1 of 3).
Connect the wire marked with "N" to the terminal with blue cable connection (select 1 of 2).
Connect the wire marked with "E" to the terminal without cable connection.

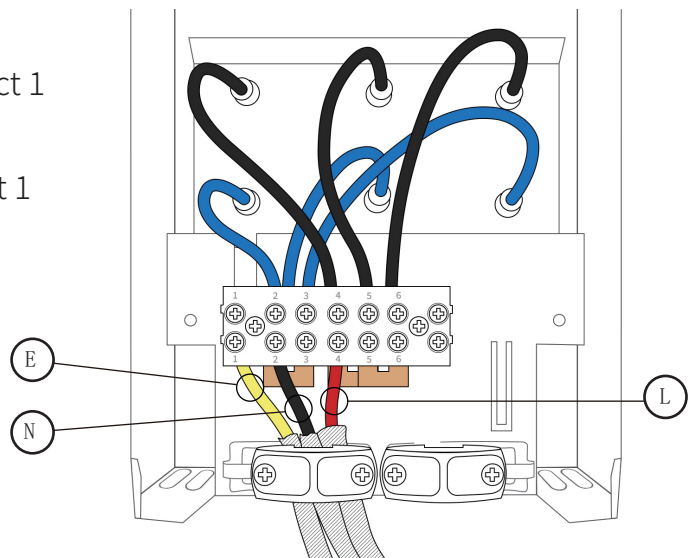

6. Steps for connecting the sauna stove's electrical wires (The wiring procedure applies to 8.0KW heaters.)

① Open the side panel of the sauna stove.

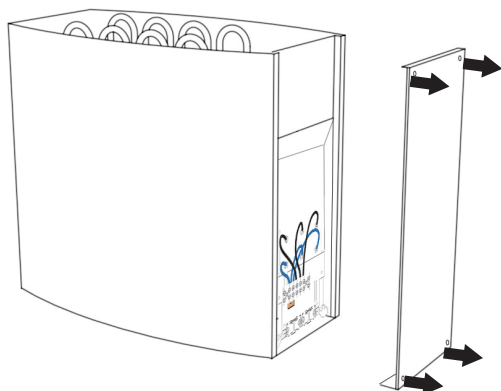

② Connect the wires of the stove.

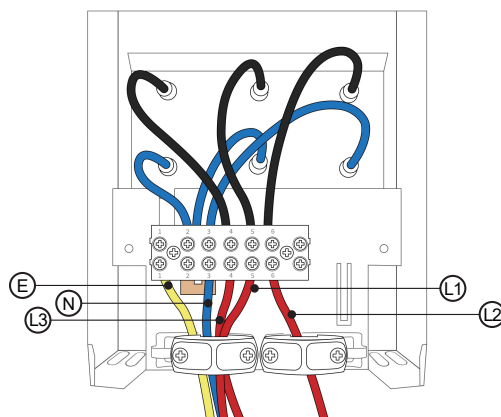

Complete the wiring as picture shown.

③ Install the furnace frame (with reserved screw holes). Note: The wooden frame has iron sheet for support; please do not remove them.
The sauna stove needs to be placed on the iron sheet.

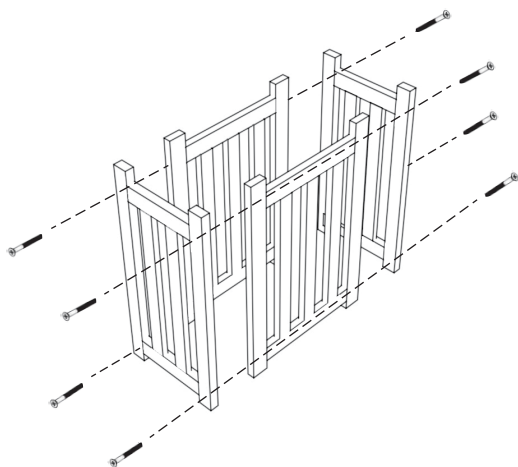

④ Place the furnace frame inside the sauna.

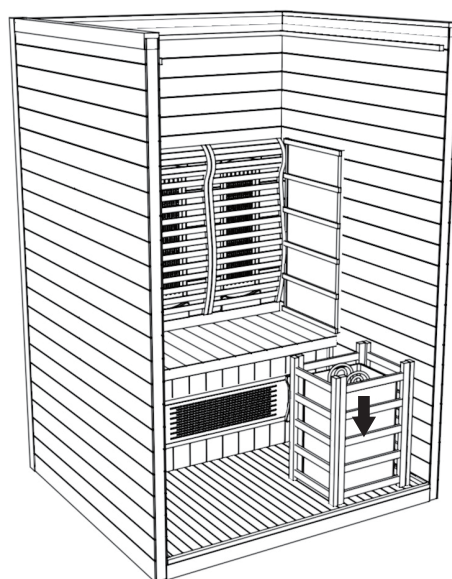

7. Internal accessories assembly steps:

① Install the door handle.

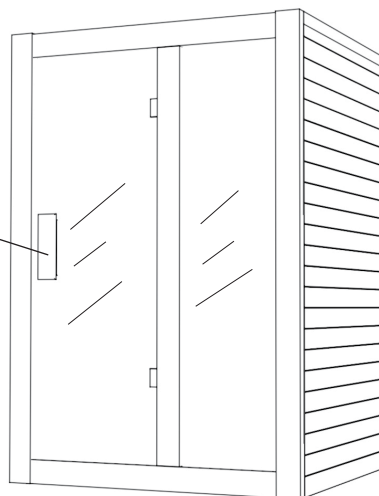
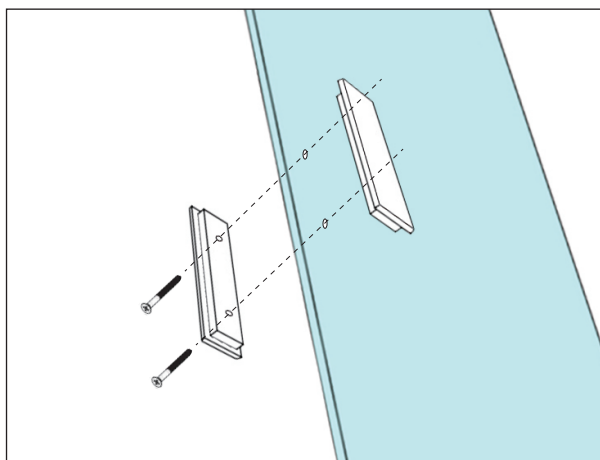

② Choose a location and use screws to fix the oxygen ionizer to the sauna.

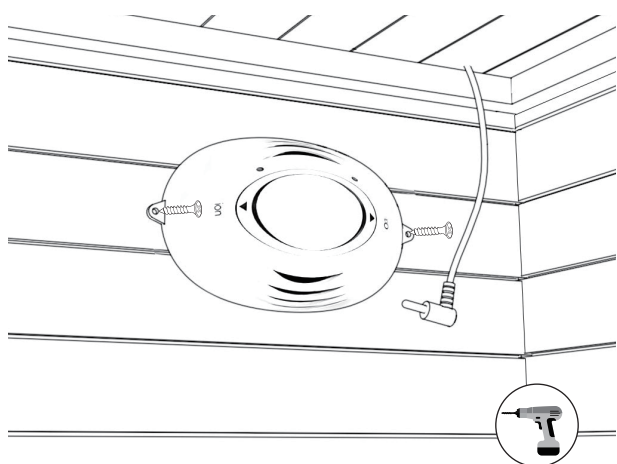

③ Connect the top wire to the oxygen ionizer.

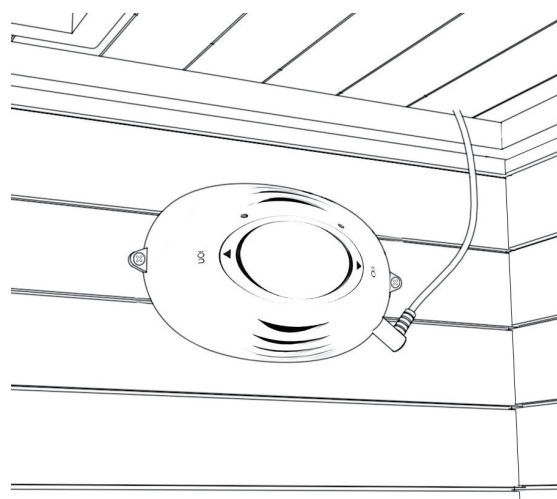

Accessories

Color Therapy Lights

Some models will include color therapy lights (or chromo lights). The color lights are operated by the remote control only. Press any color on the remote control to turn the lights on and select a color. Press the “Cycle” button (lower right button) to cycle through the colors randomly. Press the “Power” button to turn the lights off.



Wooden Bucket and Wooden Spoon

Made of natural wooden material, sturdy and durable for long service time. High quality soft plastic liner, waterproof and prevents leakage, very easy to clean. With a wide handle, convenient to take the heavy bucket filled with water. Equipped with an extra curved handle, humanized design and comfortable grip. A common accessory in all traditional sauna cabins, good for your family or friends.



Sauna Stones

Whether you prefer the steamy atmosphere of a wet sauna or the dry heat of a traditional sauna, these sauna stones offer versatility in all settings. Stones are heated up quickly, and produce and retain steam when you water them. You will be around these white steam, just like in a wonderland, that helps you relax and sweat.



Control Panel Operation Instructions



1	temperature control (reduce temperature) song select control (latter song)	8	timer control (reduce time)/ volume control (reduce volume)
2	temperature control (increase tempture)/ song select control (previous song)	9	timer control (increase time)/ volume control (increase volume)
3	AUX connect interface	10	AUX
4	FM	11	blue tooth
5	USB connect interface	12	Switch far infrared mode/steam mode
6	USB	13	power button (on/off)
7	light	/	/

1. On/Off button

Press the "  " button to turn the sauna on or off. When the power is on, the first press turns the sauna on, and the second press turns the sauna off. After setting the temperature (Infrared: 32-140 °F / Steam: 32-194 °F), the system temperature has a memory function, memorizing the last set temperature value, and the default time is the maximum value of 60 minutes.

2. Temperature setting

After turning on the sauna, press the temperature + and temperature - buttons to adjust the temperature of the light wave. The temperature adjustment range is 86-140°F (infrared) / 86-194°F (steam), with a step of 5; when the temperature is below 86 degrees, it will display -

Fahrenheit and Celsius conversion: Press and hold the TEMP + button for 10 seconds to convert between Fahrenheit and Celsius.

3. Time setting

The time can be adjusted from 5 to 60 minutes, with a step of 1. When the countdown reaches 0 minutes, the buzzer will sound 3 times, with an interval of 1.5 seconds between each sound.

4. Press the "  " button to turn the light on or off.

5. Press the "  " button to turn on the radio function, the temperature area displays the frequency, the clock area displays "XX", the time +/- adjusts the volume, the temperature +/- adjusts the frequency, there is no button response for 8 seconds, and the display switches to temperature and time.

6. Press the "  " button to turn on the AUX function, the temperature area displays AUX, the clock area displays "XX", the time +/- adjusts the volume, there is no button response for 8 seconds, and the display switches to temperature and time.

7. Press the "  " button to turn on the USB function, the temperature area displays USB, the temperature +/- adjusts the previous and next songs, the clock area displays "XX", the time +/- adjusts the volume, there is no button response for 8 seconds, and the display switches to temperature and time.

Note: The USB disk reading time is 2-3 seconds.

8. Click the "  " button, the backlight is on, turn on Bluetooth, turn on the Bluetooth of the mobile device at this time, and search to complete the Bluetooth pairing. After the pairing is successful, you can play songs. The pairing time is 6-7 seconds, the temperature area displays "T B", the clock area displays "XXdb", and the time +/- adjusts the volume. There is no button response for 8 seconds, and the display switches to temperature and time.

Note: During the Bluetooth pairing process, you cannot switch between Bluetooth, USB, and radio immediately. The switching time must be 6-7 seconds. If you switch immediately, you can switch after 6-7 seconds.

9. Press the "  " key to switch between the infrared system and the steam system. For safety reasons, the infrared system and the steam system cannot be started at the same time.

High temperature protection function:

When the sensor's detection temperature exceeds 140 degrees (infrared)/194 degrees (steam), the two digital tubes display HH at the same time, alarm and flash, all functions stop, even if the temperature drops below 140/194 degrees, the function cannot be restored, and the power must be turned off and then on again to use it normally.

Sensor fault detection:

Open circuit: The two digital tubes display " 00 " and flash, the buzzer alarms, the function cannot be turned on normally, and it can be used normally after the fault is eliminated.

Short circuit: The two digital tubes display " 11 " and flash, the buzzer alarms, the function cannot be turned on normally, and it can be used normally after the fault is eliminated.

Temperature sensor failure: The temperature digital tube displays " E0 ", the time digital tube displays normal, the buzzer alarms, and the function cannot be used normally. Check whether the wiring of the temperature sensor is normal. If it is normal, the temperature sensor needs to be changed.

WiFi network configuration:

When the mobile phone APP cannot search for the sauna, you need to debug the sauna without turning on the sauna to put it into network configuration mode.

Family 1 and Family 2 models: long press the "  " button, and hear the "di di di" sound, the sauna room network configuration is successful.

Family 3 and Family 4 models: long press the "  " button, and hear the "di di di" sound, the sauna room network configuration is successful.

Special note: The three major functions of this system, heating, lighting, and sound can be controlled independently and are not related to each other.

Saunas and Contraindications

Saunas and Medications

Individuals who are using prescription drugs should seek the advice of their personal physician or a pharmacist for possible changes in the drugs effect when the body is exposed to far infrared waves or elevated body temperature. Diuretics, barbiturates and beta-blockers may impair the body's natural heat loss mechanisms. Some over the counter drugs such as antihistamines may also cause the body to be more prone to heat stroke.

Saunas and Children

The core body temperature of children rises much faster than adults. This occurs due to a higher metabolic rate per body mass, limited circulatory adaptation to increased cardiac demands and the inability to regulate body temperature by sweating. Consult with the child's Pediatrician before using the sauna.

Saunas and the Elderly

The ability to maintain core body temperature decreases with age. This is primarily due to circulatory conditions and decreased sweat gland function. The body must be able to activate its natural cooling processes in order to maintain core body temperature.

Saunas and Cardiovascular Conditions

Individuals with cardiovascular conditions or problems (hypertension / hypo tension), congestive heart failure, impaired coronary circulation or those who are taking medications, which might affect blood pressure, should exercise extreme caution when exposed to prolonged heat. Heat stress increases cardiac output, blood flow, in an effort to transfer internal body heat to the outside environment via the skin (perspiration) and respiratory system. This takes place primarily due to major changes in the heart rate, which has the potential to increase by thirty (30) beats per minute for each degree increase in core body temperature.

Saunas and Alcohol

Contrary to popular belief, it is not advisable to attempt to "Sweat Out" a hangover. Alcohol intoxication decreases a person's judgment; therefore they may not realize it when the body has a negative reaction to high heat. Alcohol also increases the heart rate, which may be further increased by heat stress.

Saunas and Chronic Conditions / Diseases Associated With a Reduced Ability to Sweat or Perspire

Parkinson's, Multiple Sclerosis, Central Nervous System Tumors and Diabetes with Neuropathy are conditions that are associated with impaired sweating.

Saunas and Hemophiliacs / Individuals Prone To Bleeding

The use of Infrared saunas should be avoided by anyone who is predisposed to bleeding.

Saunas and Fever

An individual that has a fever should not use any type of sauna.

Saunas and Insensitivity to Heat

An individual that has insensitivity to heat should not use any type of sauna.

Saunas and Pregnancy

Pregnant women should consult a physician before using any type of sauna because fetal damage can occur with a certain elevated body temperature.

Saunas and Menstruation

Heating of the low back area of women during the menstrual period may temporarily increase their menstrual flow. Some women endure this process to gain the pain relief commonly associated with their cycle whereas others simply choose to avoid saunas use during that time of the month.

Saunas and Joint Injury

If you have a recent (acute) joint injury, it should not be heated for the first 48 hours after an injury or until the hot and swollen symptoms subside. If you have a joint or joints that are chronically hot and swollen, these joints may respond poorly to vigorous heating of any kind. Vigorous heating is strictly contra-indicated in cases of enclosed infections be they dental, in joints or in any other tissues.

Saunas and Implants

Metal pins, rods, artificial joints or any other surgical implants generally reflect far infrared waves and thus are not heated by this system; nevertheless you should consult your surgeon prior to using an Infrared Sauna. Certainly, the usage of an Infrared Sauna must be discontinued if you experience pain near any such implants. Silicone does absorb far infrared energy. Implanted silicone or silicone prostheses for nose or ear replacement may be warmed by the far infrared waves. Since silicone melts at over 200°C (392°F), it should not be adversely affected by the usage of Infrared saunas. It is still advised that you check with your surgeon and possibly a representative from the implant manufacturer to be certain.

In the rare event, you experience pain and/or discomfort, immediately discontinue sauna use.

Warranty Policy

Dear customer:

First of all, thank you for choosing to buy our products!

In order to ensure product quality, specify product quality.

The responsibility of both parties is to ensure that the product quality is qualified, and to ensure product safety, the following guarantees are hereby made:

Warranty scope:

All accessories in the sauna room including wooden planks and slats, etc.

Warranty period for wooden planks, wooden accessories (stools, backrests, headrests) :
3 years from the date of arrival;

Warranty period for lamps, control boards, oxygen bars, reading lights, etc.: 3 years from the date of arrival.

Warranty:

(1) During the 1-year warranty period, in the case of non-human damage, all accessories, free replacement, and the shipping cost will be borne by the seller.

(2) During the 1-year warranty period, if all accessories are due to human factors, our company will be responsible for free replacement, and the freight will be borne by the buyer.

(3) During the warranty period of more than one year (not including one year), if all accessories are damaged due to non-human factors, our company can replace them for the customer at the cost price, and the freight will be borne by the seller.

(4) During the warranty period of more than one year (not including one year), if all accessories are damaged due to human factors, our company can replace them for the customer at the cost price, and the freight will be borne by the buyer.

The final interpretation of this warranty policy belongs to the company.