

# ASSEMBLY INSTRUCTIONS

## 6PCS Dining Table Set

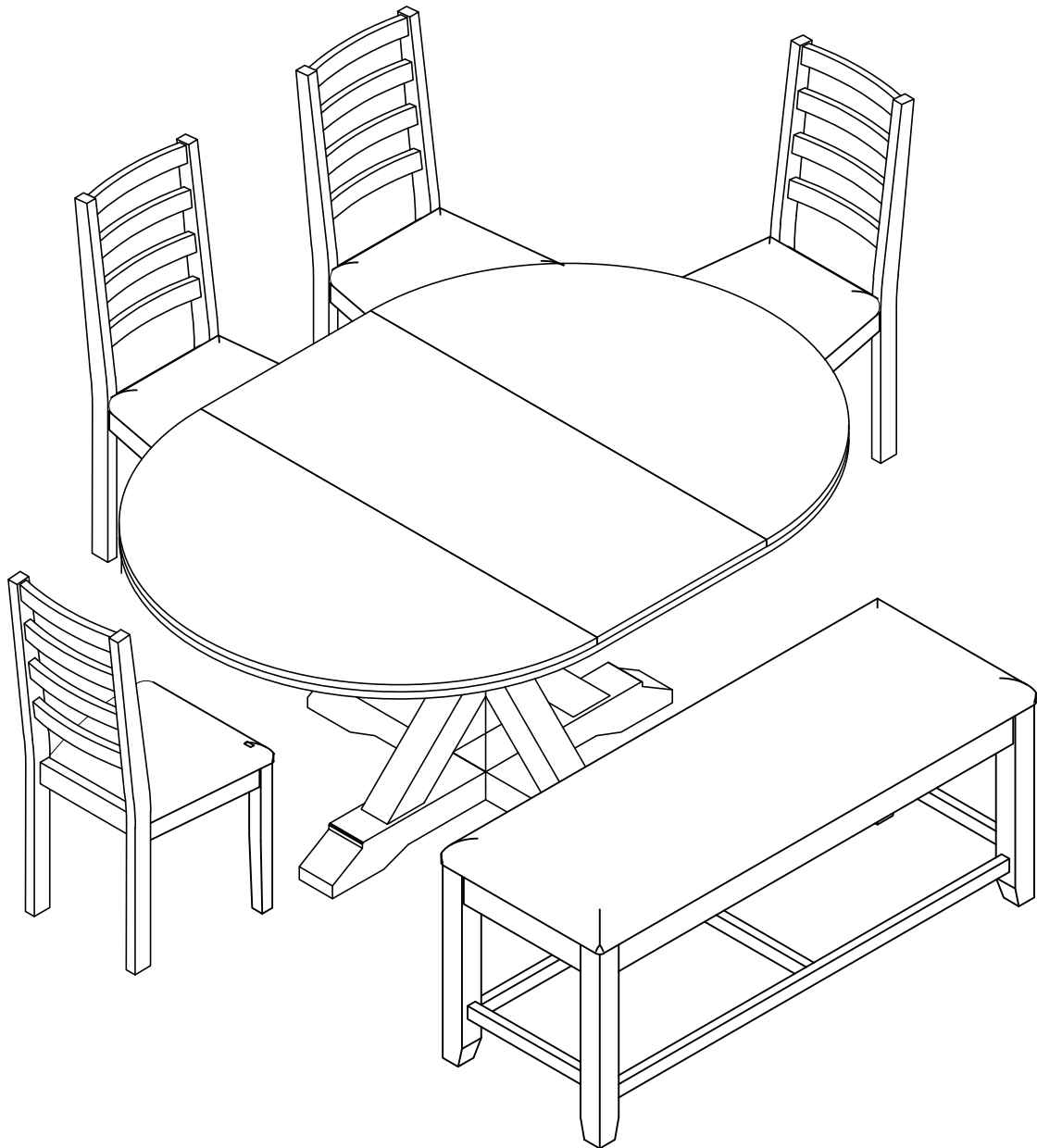

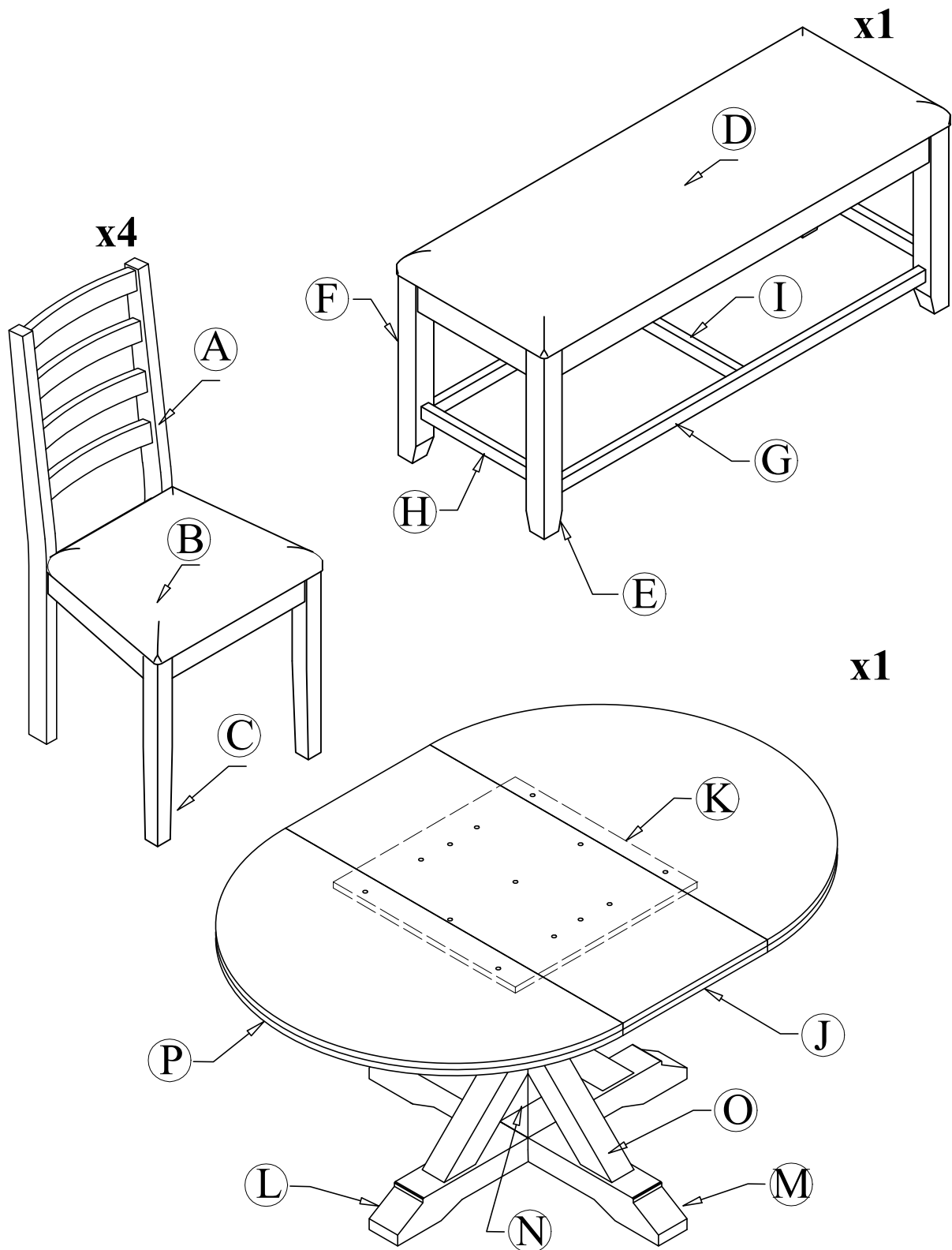

**Notice:**

1. 50% Tighten before fixing all screws, Allen wrench is recommended instead of an electric drill.
2. Place the item on a flat ground to adjust and make sure it remains stable.
3. Tighten up all screws with tools gradually.
4. If the screws are not aligned with holes during assembly, please loosen all the other screws to 50% and continue the assembly process.
5. If the item is not stable , please loosen all the screws, adjust it on a flat ground and tighten up all screws again.
6. Note:If one or some screws are fully tightened during assembly , chances are the others will not be aligned with holes . In addition ,all the holes are designed to be relatively larger to provide more space for the adjustment of the screws.

# CARTON CONTENT:

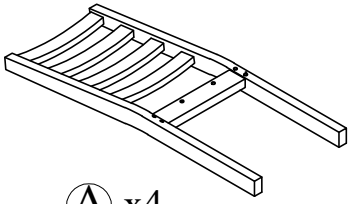

Ⓐ x4

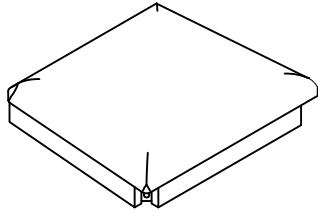

Ⓑ x4

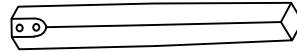

Ⓒ x8

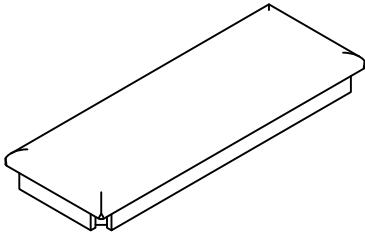
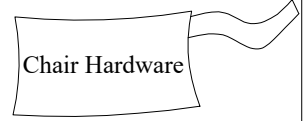

Ⓓ x1

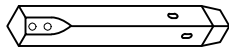

Ⓔ x2

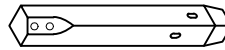

Ⓕ x2

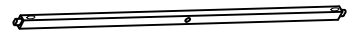

Ⓖ x2

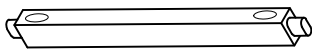

Ⓗ x2

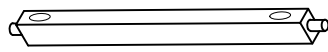

Ⓘ x1

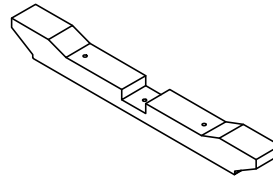

Ⓛ x1

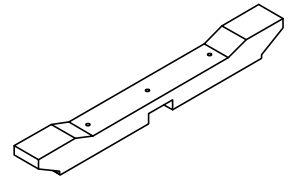

Ⓜ x1

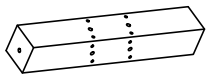

Ⓝ x1

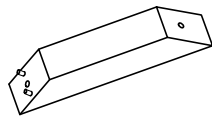

Ⓞ x8

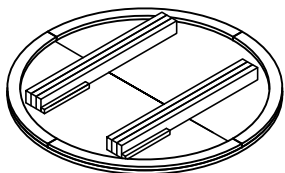
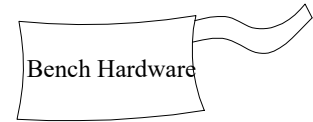

Ⓟ x1

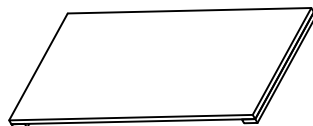

Ⓝ x1

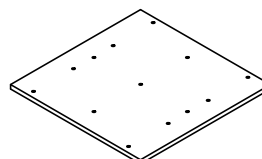

Ⓚ x1



# Part List

**A**

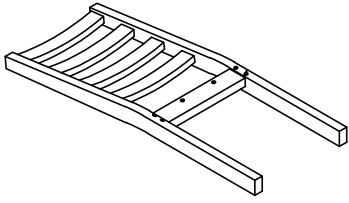

(4PCS)

**B**

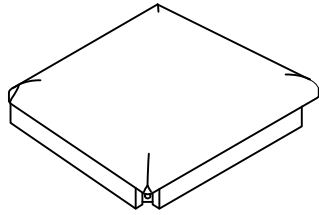

(4PCS)

**C**

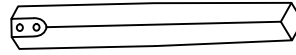

(8PCS)

**D**

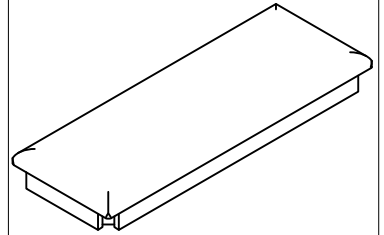

(1PC)

**E**

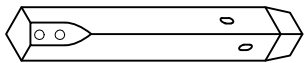

(2PCS)

**F**

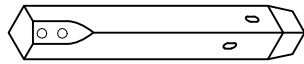

(2PCS)

**G**



(2PCS)

**H**

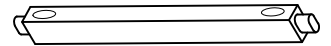

(2PCS)

**I**

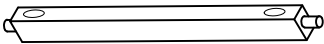

(1PC)

**P**

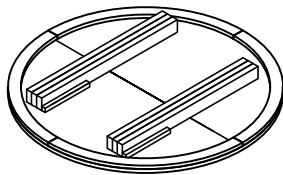

(1PC)

**J**

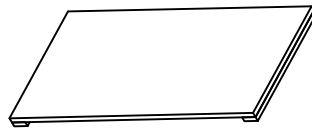

(1PC)

**K**

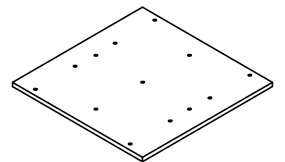

(1PC)

**L**

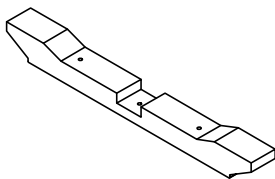

(1PC)

**M**

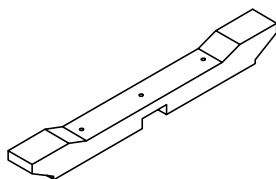

(1PC)

**N**

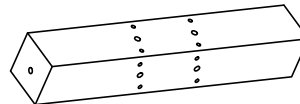



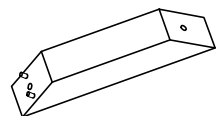

(1PC)

**O**



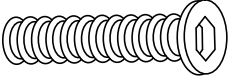
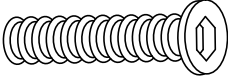
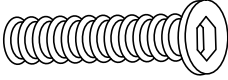

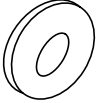

(8PCS)



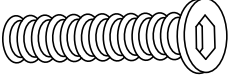

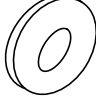
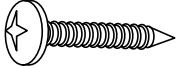

## CHAIR Hardware

<p>① x 16 PCS</p>  <p>BOLT Ø1/4"x 50mm</p>	<p>② x 4 PCS</p>  <p>BOLT Ø1/4"x 32mm</p>	<p>③ x 16 PCS</p>  <p>BOLT Ø1/4"x 80mm</p>	<p>④ x 36PCS</p>  <p>FLAT WASHER Ø1/4"x 13mm</p>
<p>⑤ x 36PCS</p>  <p>LOCK WASHER Ø1/4"x 19mm</p>	<p>⑥ x 1 PC</p>  <p>ALLEN KEY 4mm</p>		

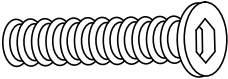
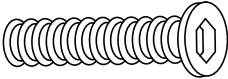
## BENCH Hardware

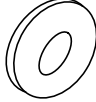
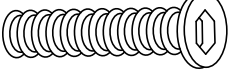
<p>① x 8PCS</p>  <p>BOLT Ø1/4"x 50mm</p>	<p>② x 8PCS</p>  <p>FLAT WASHER Ø1/4"x 13mm</p>	<p>③ x 8PCS</p>  <p>LOCK WASHER Ø1/4"x 19mm</p>	<p>④ x 10PCS</p>  <p>SCREW M4x38mm</p>
<p>⑤ x 1 PC</p>  <p>ALLEN KEY 4mm</p>	 <p>ASSEMBLY TOOLS REQUIRED (NOT INCLUDED)</p>		

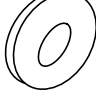
## TABLE Hardware

<p>① x 1PCS</p>  <p>BOLT Ø5/16"x 90mm</p>	<p>② x 17PCS</p>  <p>BOLT Ø5/16"x 50mm</p>	<p>③ x 18PCS</p>  <p>FLAT WASHER Ø5/16"x 13mm</p>	<p>④ x 18PCS</p>  <p>LOCK WASHER Ø5/16"x 19mm</p>
<p>⑤ x 4PCS</p>  <p>BOLT Ø1/4"x 40mm</p>	<p>⑥ x 4PCS</p>  <p>FLAT WASHER Ø1/4"x 13mm</p>	<p>⑦ x 4PCS</p>  <p>LOCK WASHER Ø1/4"x 19mm</p>	<p>⑧ x 1 PC</p>  <p>ALLEN KEY 4mm</p>

## STEP 1:

Ⓑ X 1

Ⓒ X 2

⑤ X 4

④ X 4

① X 4

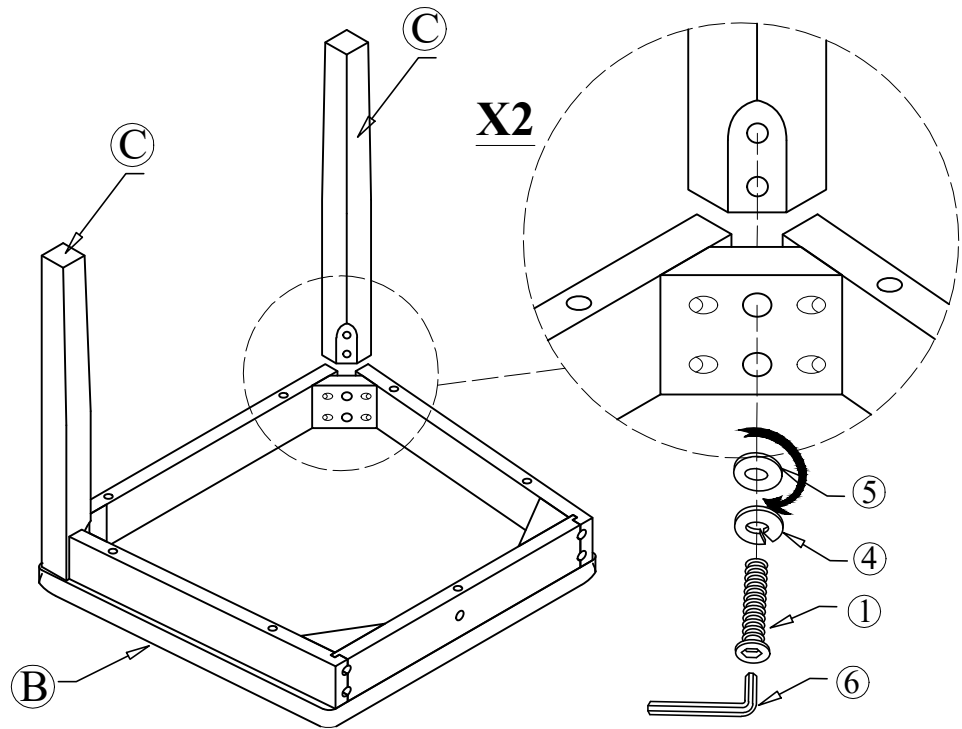

Connect the Front Leg (C) and Cushion Seat (B), tighten Bolt (1), Flat Washer (4), Lock Washer (5) with Allen Key (6)

## STEP 2:

Ⓐ X 1

⑤ X 5

④ X 5

③ X 4

② X 1

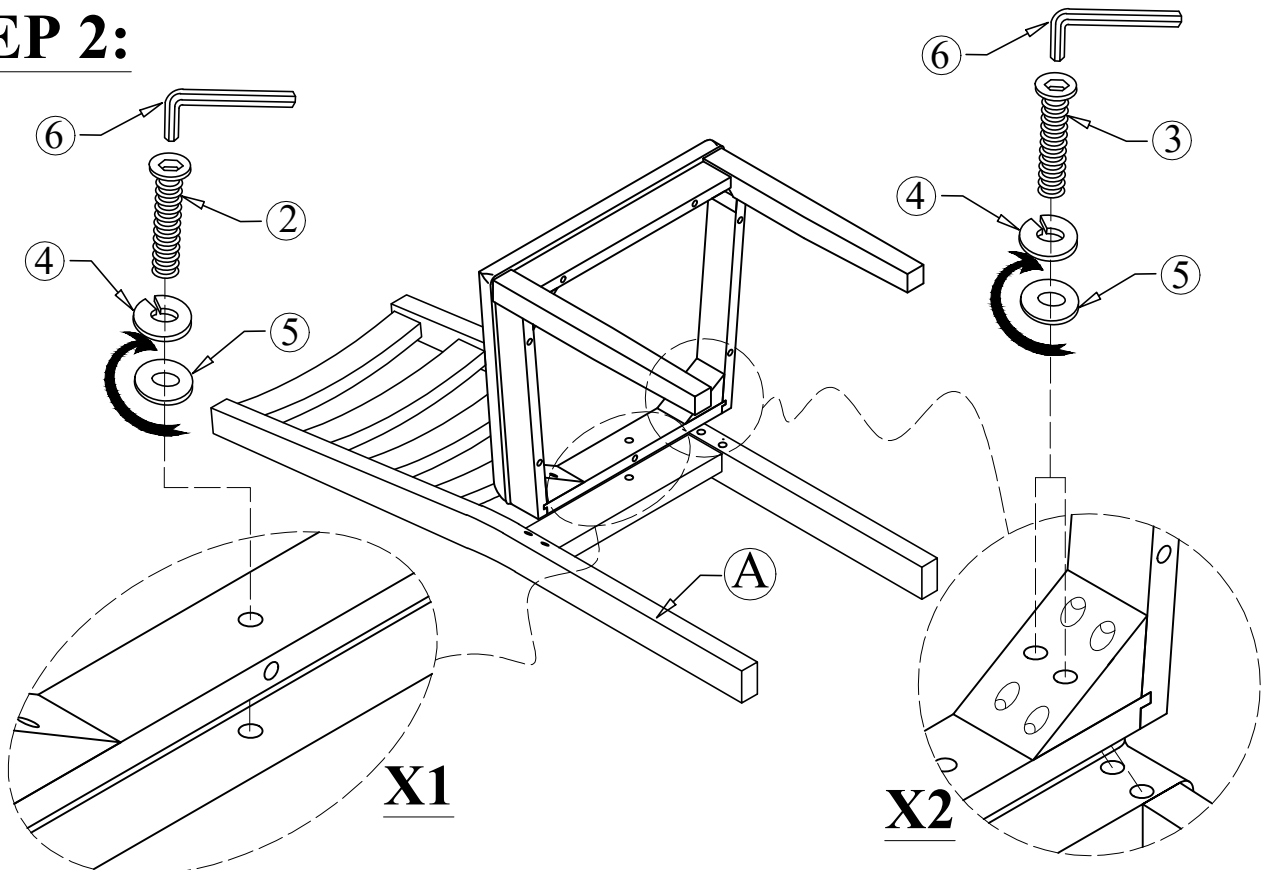

Connect The Part from Step 1 and Chair Back (A), tighten Bolt (2), Bolt (3), Flat Washer (4), Lock Washer (5) with Allen Key (6)

## STEP 1:

- Ⓓ X 1
- Ⓔ X 2
- Ⓕ X 2
- Ⓗ X 2
- ③ X 8
- ② X 8
- ① X 8

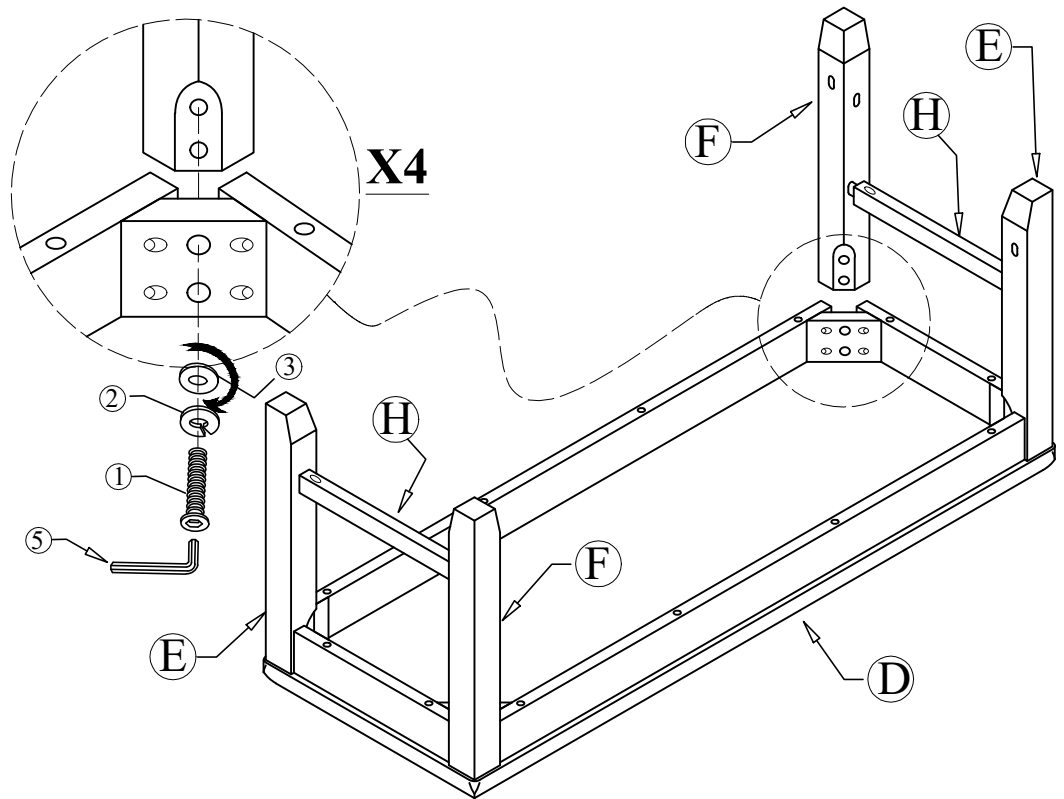

Connect the Front Left Leg (E) and Front Right Leg (F) and Cushion Seat (D) and Side Stretcher (H), tighten Bolt (1), Flat Washer (2), Lock Washer (3) with Allen Key (5)

## STEP 2:

- Ⓖ X 2
- Ⓘ X 1
- ④ X 10

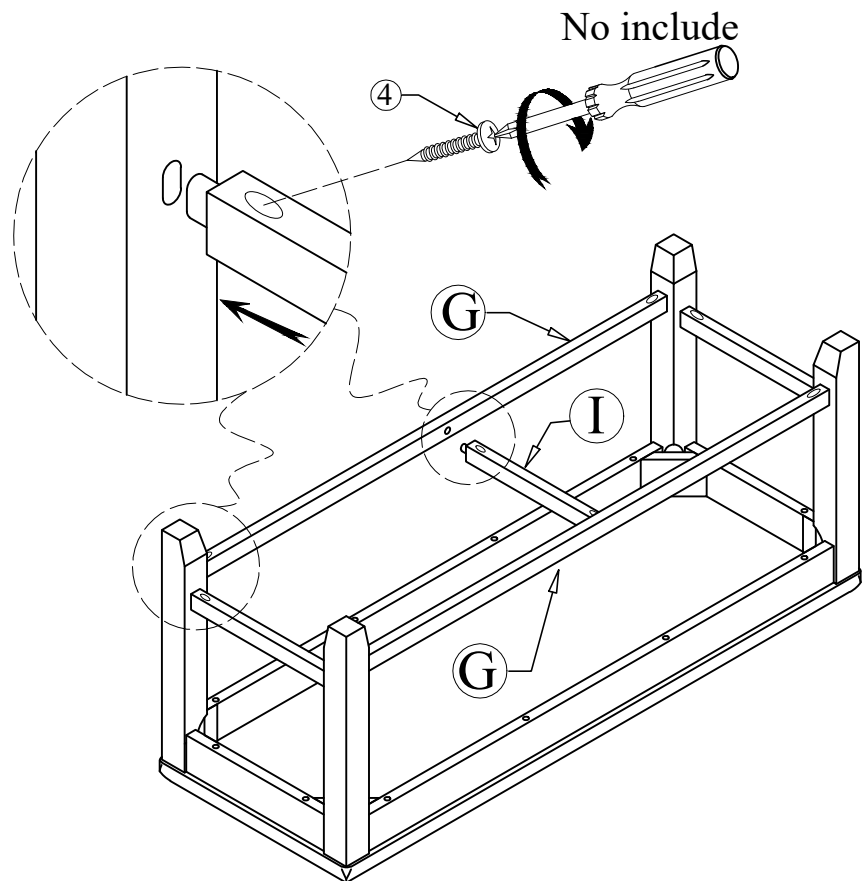

Connect The Part from Step 1 and the Front Stretcher (G) , connect Medium Stretcher (I) to Front Stretcher (G), tighten Screw (4) with assembly tool (not included).

## STEP 1:

- Ⓛ x 1
- Ⓜ x 1
- Ⓞ x 4
- Ⓝ x 1
- ③ x 9
- ④ x 9
- ② x 8
- ① x 1

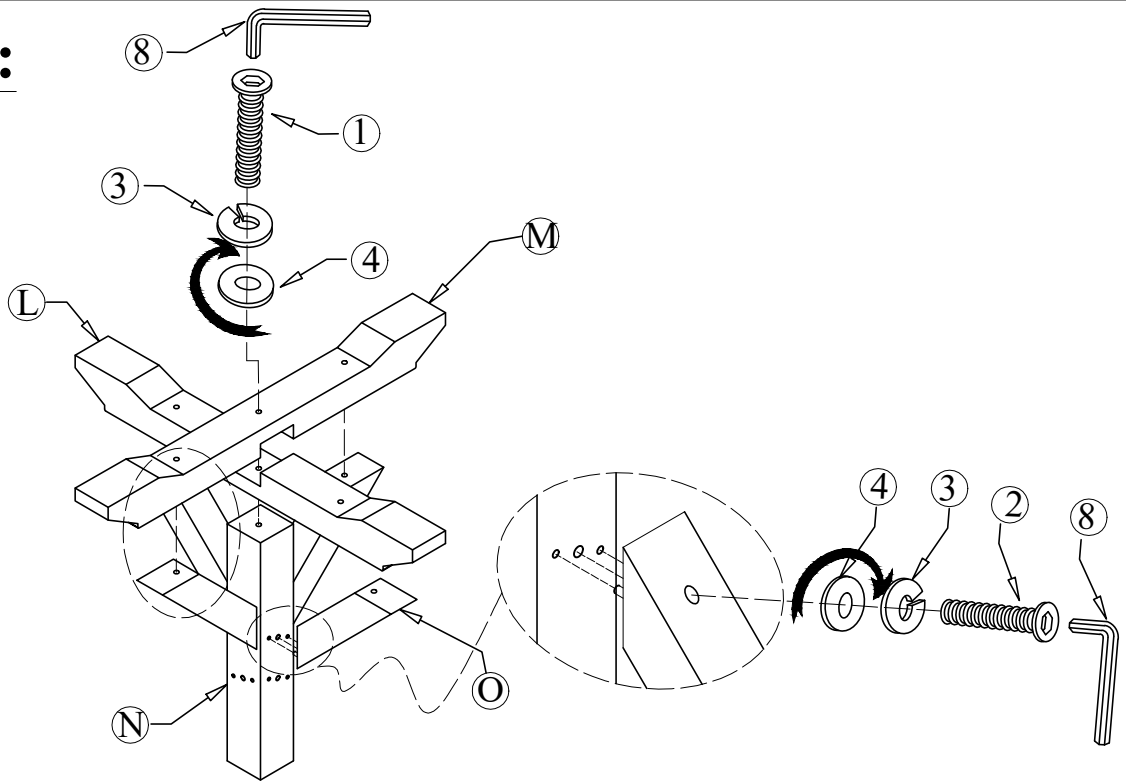

Connect the base legs (L) and (M) and straight leg (N), tighten Bolt (1), Flat Washer (3), Lock Washer (4) with Allen Key (8).

Connect support legs (O) and straight leg (N), tighten Bolt (2), Flat Washer (3), Lock Washer (4) with Allen Key (8).

Connect support legs (O) and base legs (L) and (M), tighten Bolt (2), Flat Washer (3), Lock Washer (4) with Allen Key (8).

## STEP 2:

- Ⓚ x 1
- Ⓞ x 4
- ② x 9
- ③ x 9
- ④ x 9

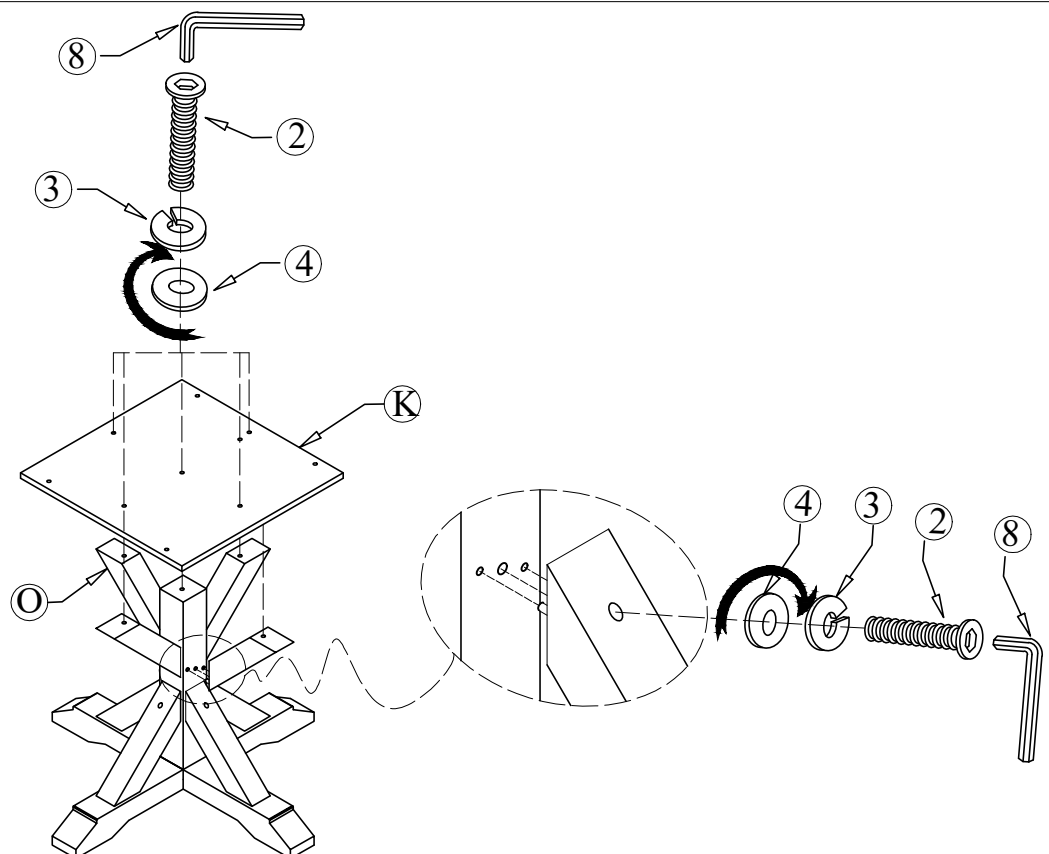

Connect the part from step 1, support legs (O) to panel (K), tighten Bolt (2), Flat Washer (3), Lock Washer (4) with Allen Key (8).

### STEP 3:

- Ⓟ X 1
- ⑦ X 4
- ⑥ X 4
- ⑤ X 4

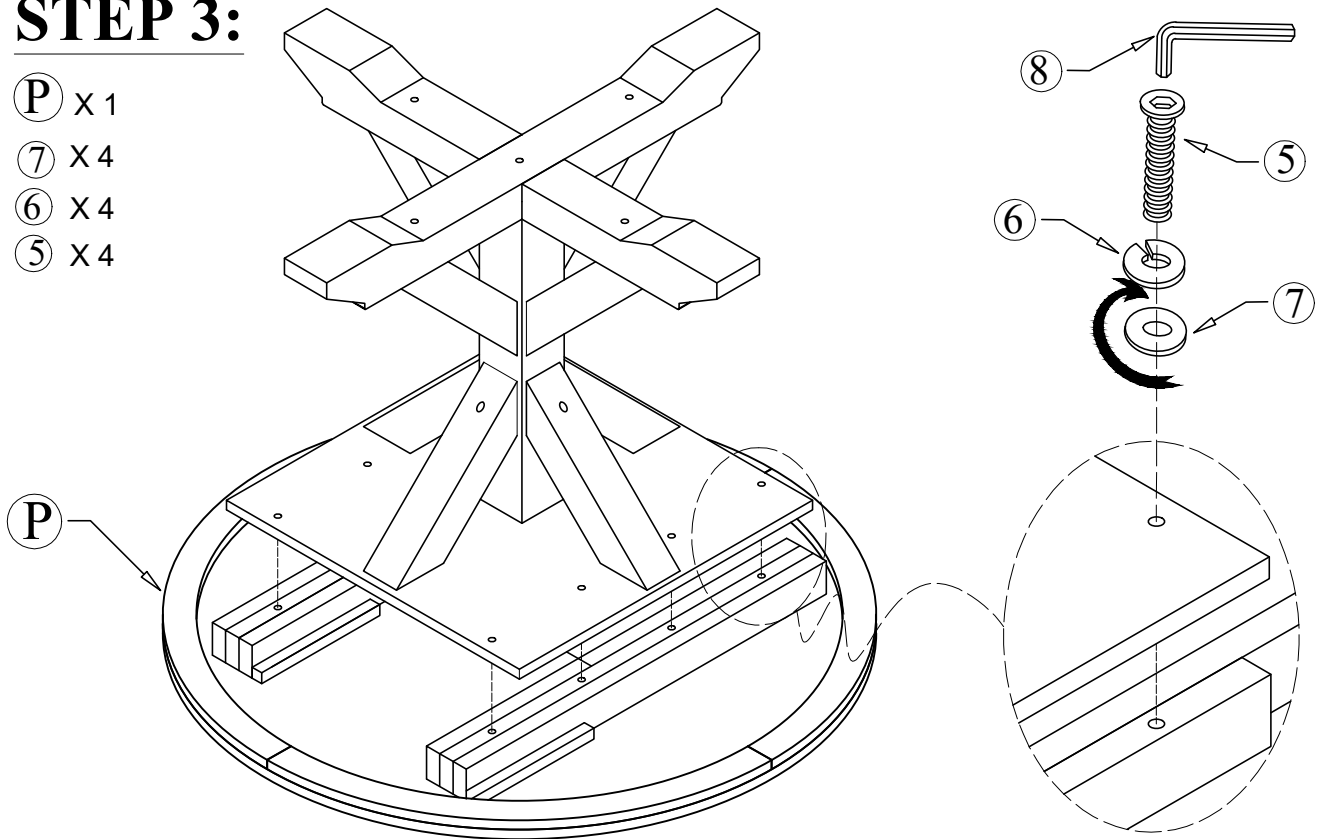

Connect the part from step 2 to the top panel (P), tighten Bolt (5), Flat Washer (6), Lock Washer (7) with Allen Key (8).

### STEP 4:

- Ⓟ X 1

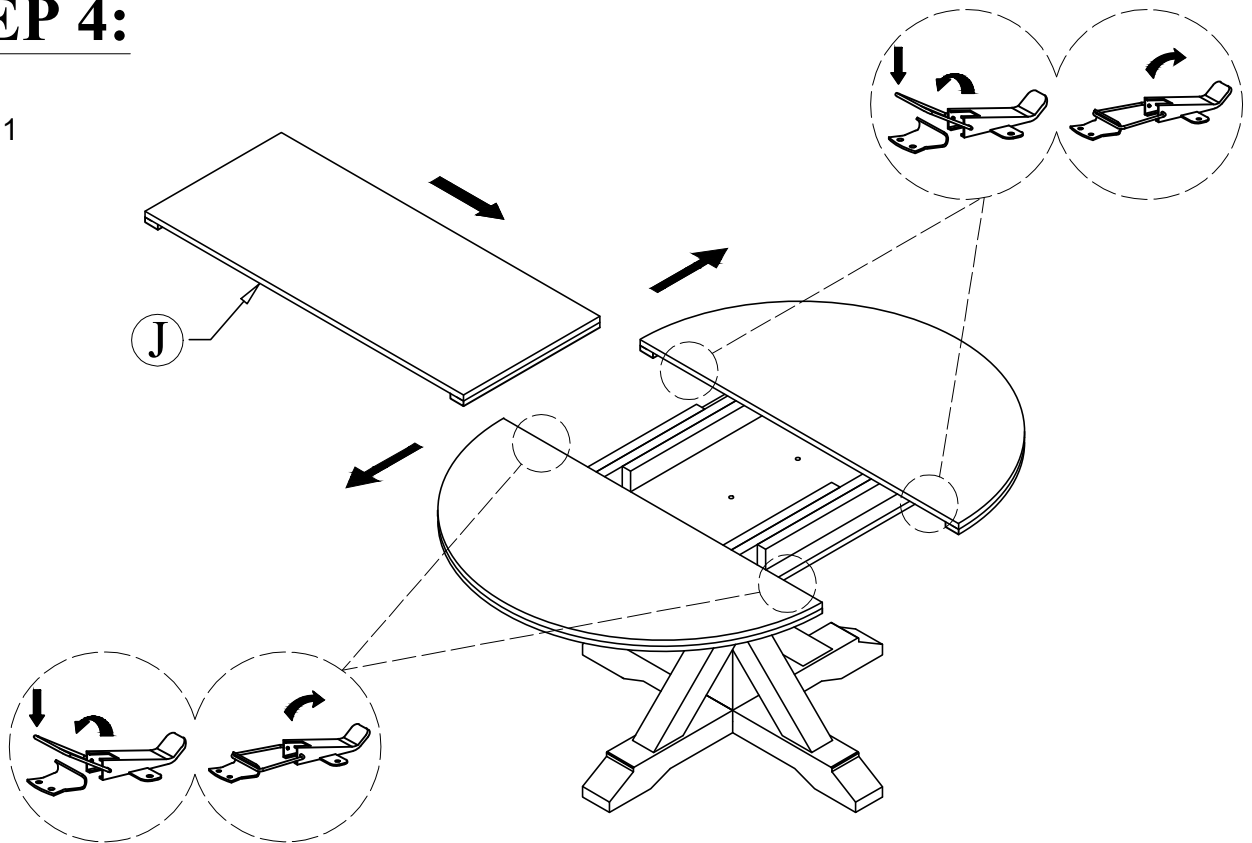

Open the 4 lockers under the top panel (P), drag them to side, put the medium panel (J) into the middle, fit the position then close the lockers.