

NOTICE

- * Please make sure that you have all parts indicated and they are in good condition before you begin assembly of this item. Refer to part list and hardware list below for guidance.
- * This item should be assembled on a soft surface to prevent scratching the finish during assembly.
- *This item may require periodic tightening.
- * If you are having difficulty, our friendly Customer Care team is always here to help.

PREPARATION

- * Before beginning assembly of product, make sure all parts are present. Compare parts with part contents list and hardware contents list.
- * If any part is missing or damaged, do not attempt to assemble the product.
- * Estimated Assembly Time: **10 minutes**.
- * Tools Required for Assembly (included): **Allen Key**







CARE AND MAINTENANCE

Wipe spills immediately. Maintain with regular dusting and clean with mild soap and water, dry thoroughly and do not use a brass cleaner.

Adhesive felt pads should always be used/applied in order to prevent damage to the furniture or surfaces on which the furniture is placed.

Always use felt pads under all articles to prevent discoloration or softening of the lacquer. Plastic and rubber bases on items can discolor wood. Wipe up spills immediately and avoid common hazards such as hot dishes, harsh solvents and abrasives. Cleaning should be done with a soft lint free cotton cloth dampened with water or furniture polish. On highly used surfaces we recommend applying a quality paste wax which should be used on a regular basis to provide additional protection from scratches and spills. How often you apply the wax depends on how much wear the furniture receives.

Part List and Hardware List

Piece	Description	Picture	Quantity
A	Top		1 X
B	Leg		4 X
C	Shelf		16X
HW1	Allen Bolt (M6x1x12mm)		16X
HW2	Adjustable Feet Leveler		4 X
HW3	Allen Key		1X

FURNITURE

Product Dimensions: 26.25"Wx14.25"Dx25.8"H

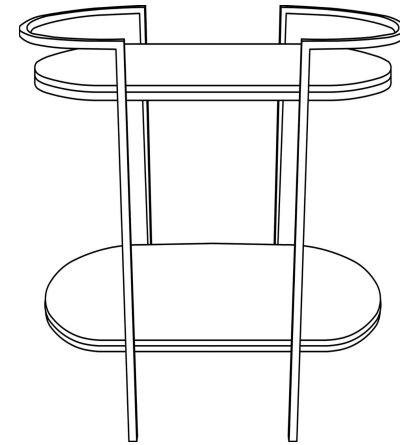

⚠ WARNING ⚠

Weight Capacity-50LBS

Warning:Do not stand on Shelf

Warning:Do not over torque bolts.

Preparation

- *Before beginning assembly of product, make sure all parts are present. Compare parts with package contents list and hardware contents list.
- *If any part is missing or damaged, do not attempt to assemble the product.
- *Estimated Assembly Time: 10 minutes.
- *Tools Required for Assembly (included):Allen Key
- * If you are having difficulty, our friendly Customer Care team is always here to help.

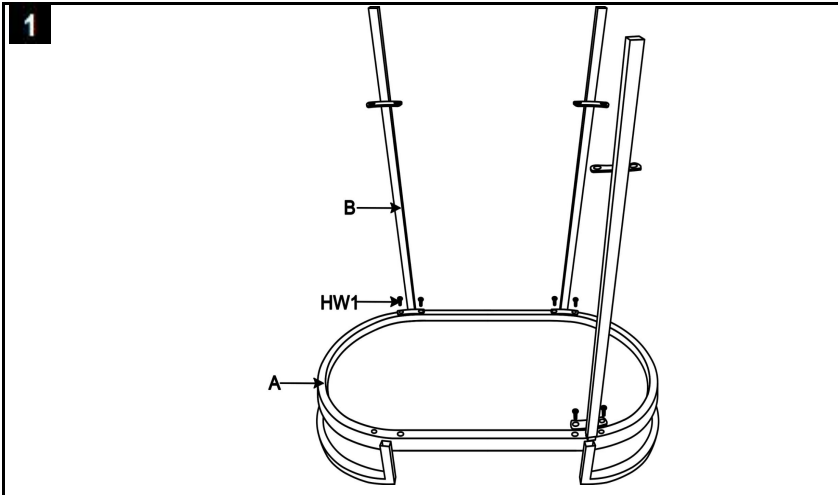

Attach the Legs(B) to the Top (A), using Allen bolts(HW1).
Do not over torque

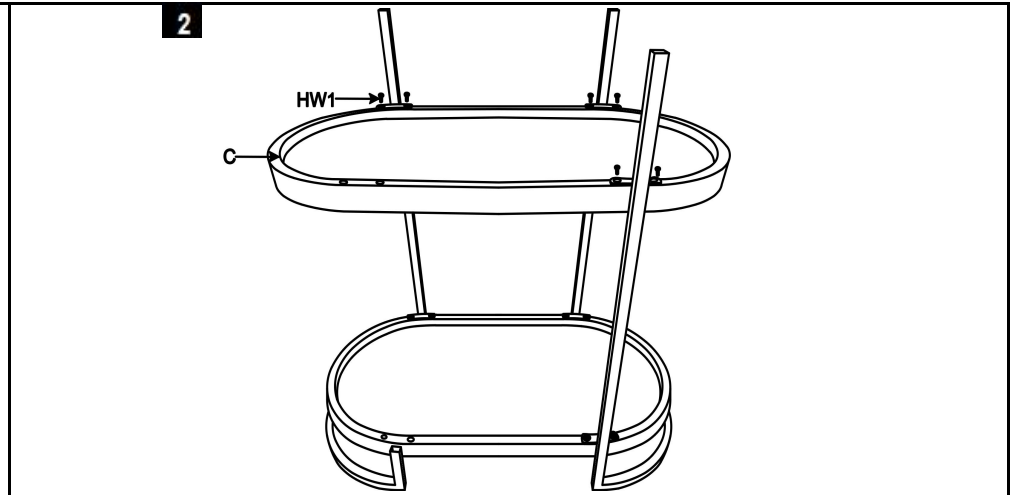

Attach the Shelf(C) to Legs,using Allen bolts(HW1).Do not over torque

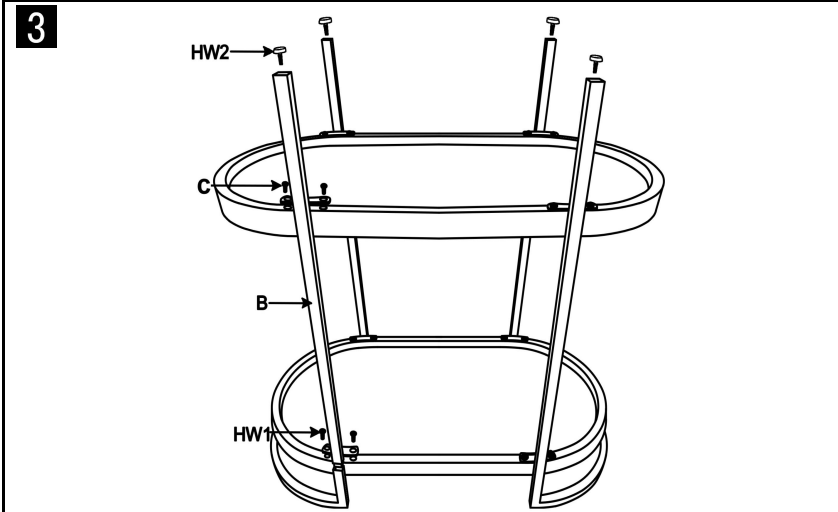

Attach the Legs(B) to the Top and Shelf, tighten all Allen bolts(HW1).
Then install the Adjustable Feet Leveler(HW2)