

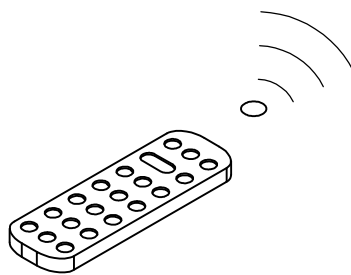

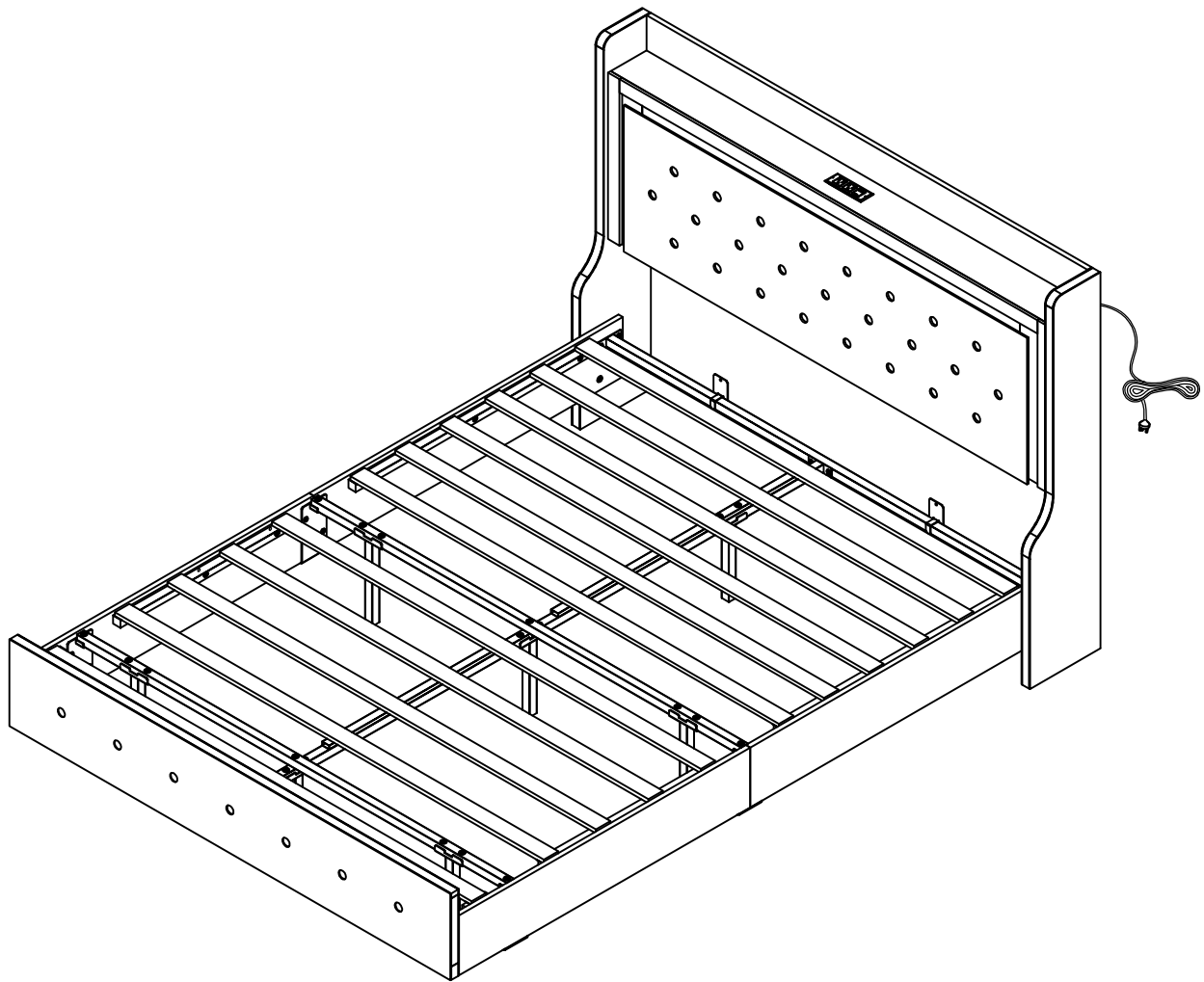

ASSEMBLY INSTRUCTION

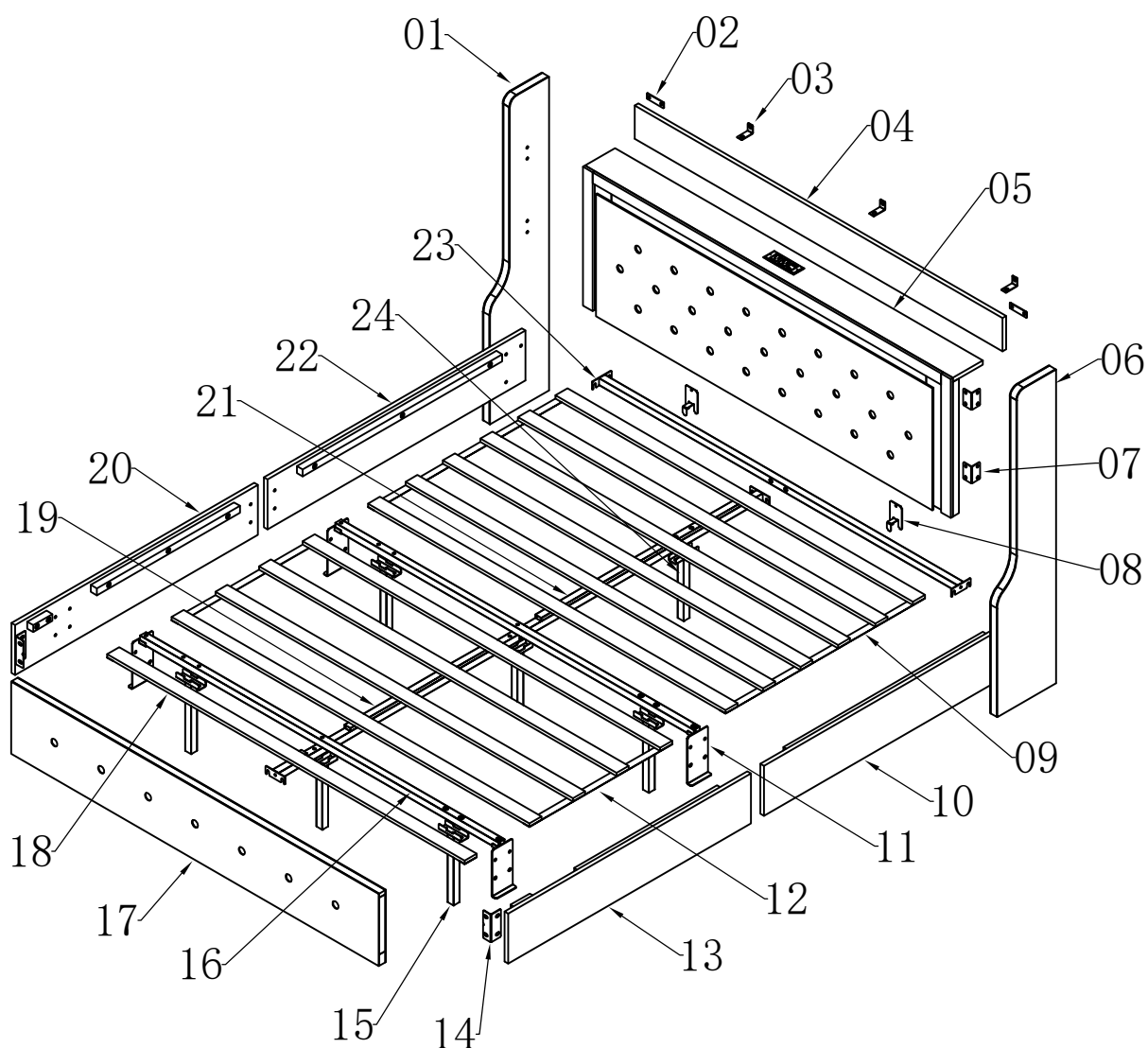

Schematic diagram of parts disassembly and installation numbering

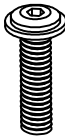
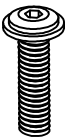

Hardware list

 (A)	 (B)	 (C)	 (D)
M8×15mm 54pcs+5pcs	M8×35mm 22pcs+2pcs	M8×60mm 4pcs	M5 1pc

Tips: The number after “+” represents the spare hardware.

Teileliste Liste des pieces

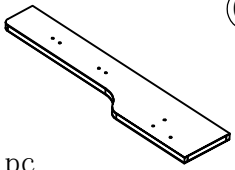
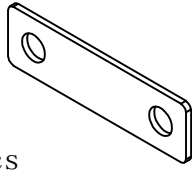
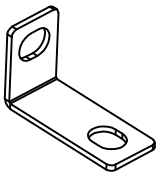
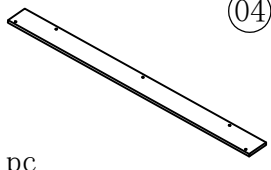
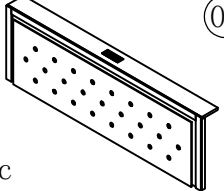
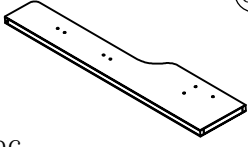
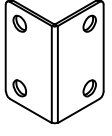
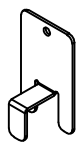
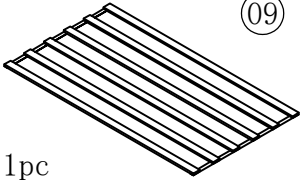
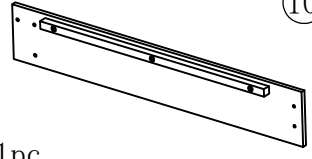
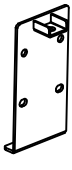
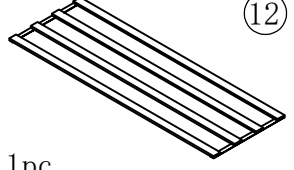
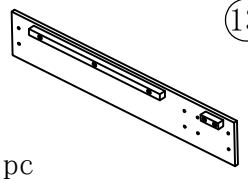
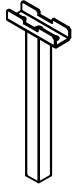
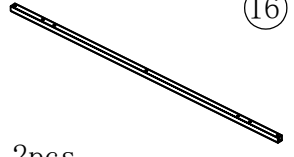
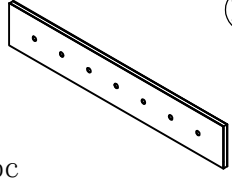
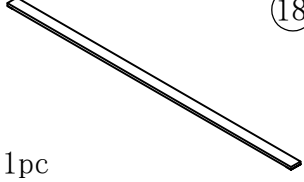
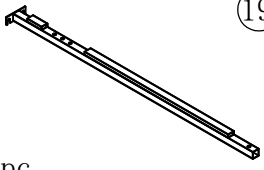
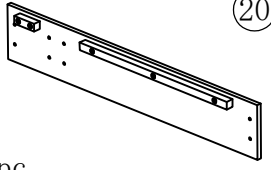
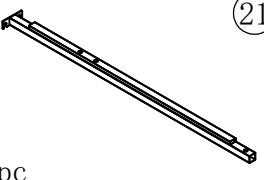
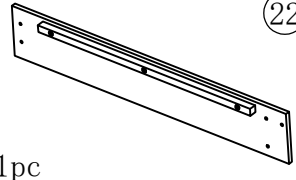
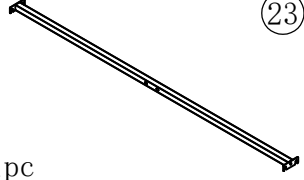
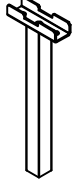
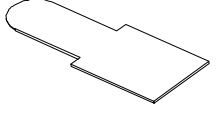
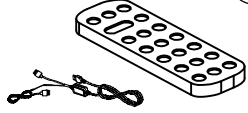
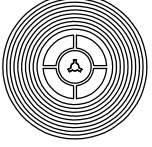
 1pc	 2pcs	 3pcs	 1pc
 1pc	 1pc	 4pcs	 2pcs
 1pc	 1pc	 4pcs	 1pc
 1pc	 2pcs	 4pcs	 2pcs
 1pc	 1pc	 1pc	 1pc
 1pc	 1pc	 1pc	 3pcs
 2pcs Velcro	 1pc	 1pc	

' SAFETY TIPS:

Static charge may cause duston foam clean with a dry or damp cioth.
 Smafoam strands may oepresent -handie gently and dispose of properly.
 Do not burn or incinerate.
 Check local recycling quldelines.

Preintall to 80% first

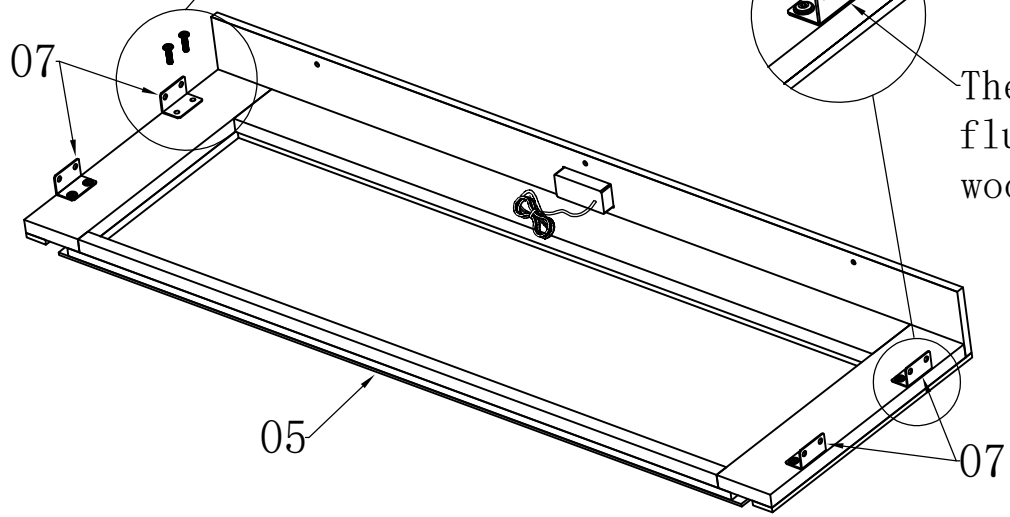
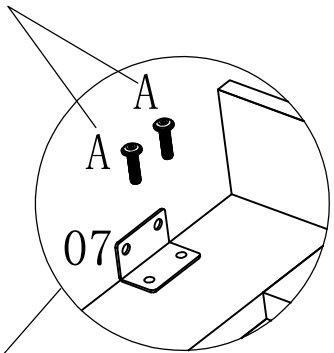

SCHRITT

Etapes1

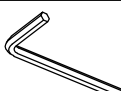
A		M8×15mm	8pcs
D		M5	1pc

The iron plate is flush with the wooden board.

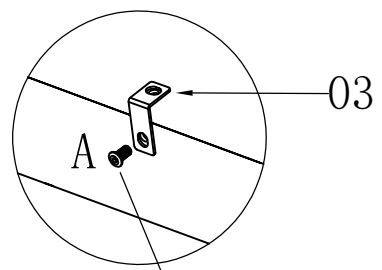

Preintall to 80% first

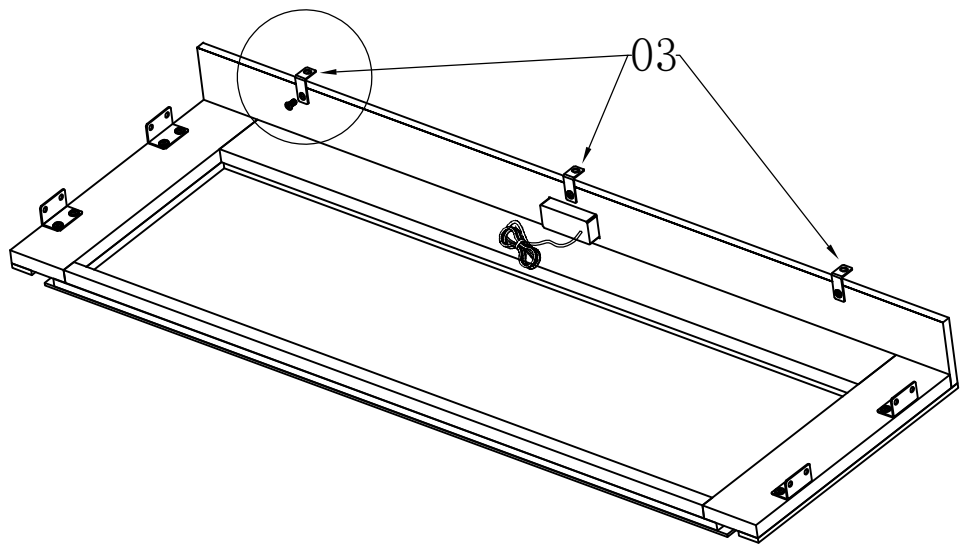

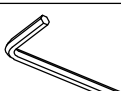

SCHRITT

Etapes2

A		M8×15mm	3pcs
D		M5	1pc

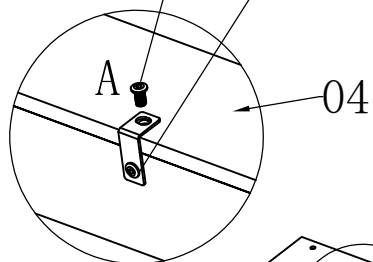
All screws are tightened 80%

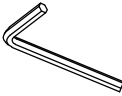

SCHRITT		Etapas3	
A		M8×15mm	3pcs
D		M5	1pc

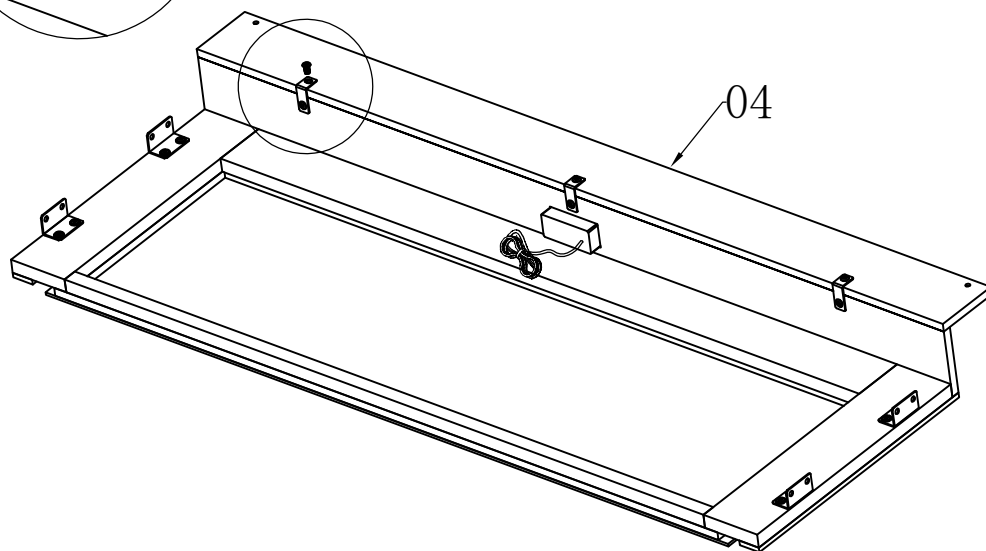

First lock both sides at 80%

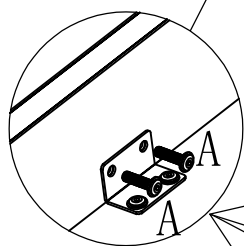

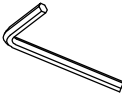

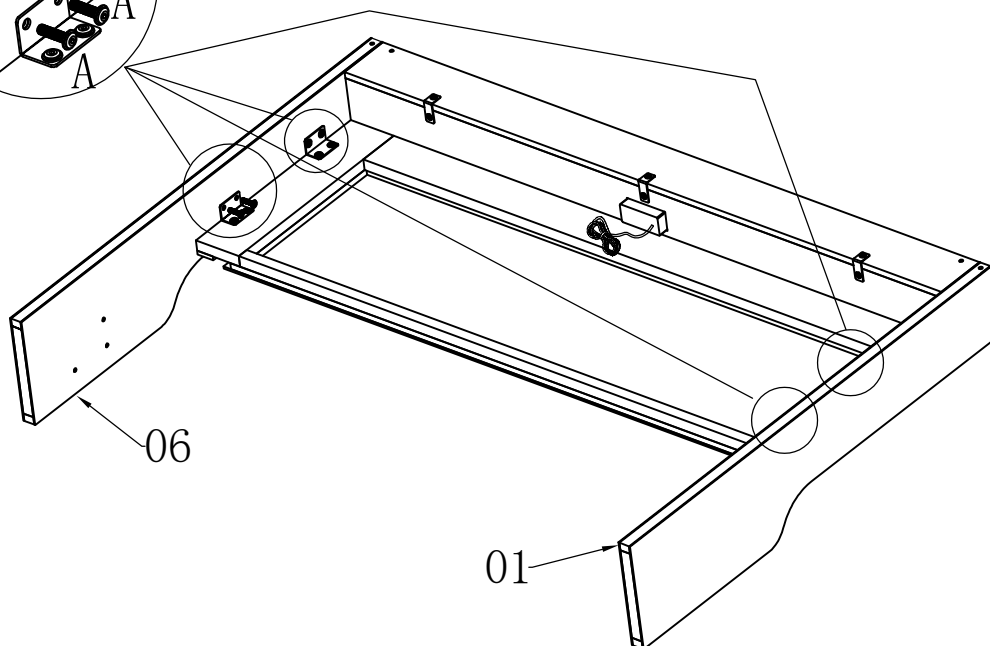
SCHRITT		Etapas4	
A		M8×15mm	8pcs
D		M5	1pc

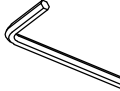

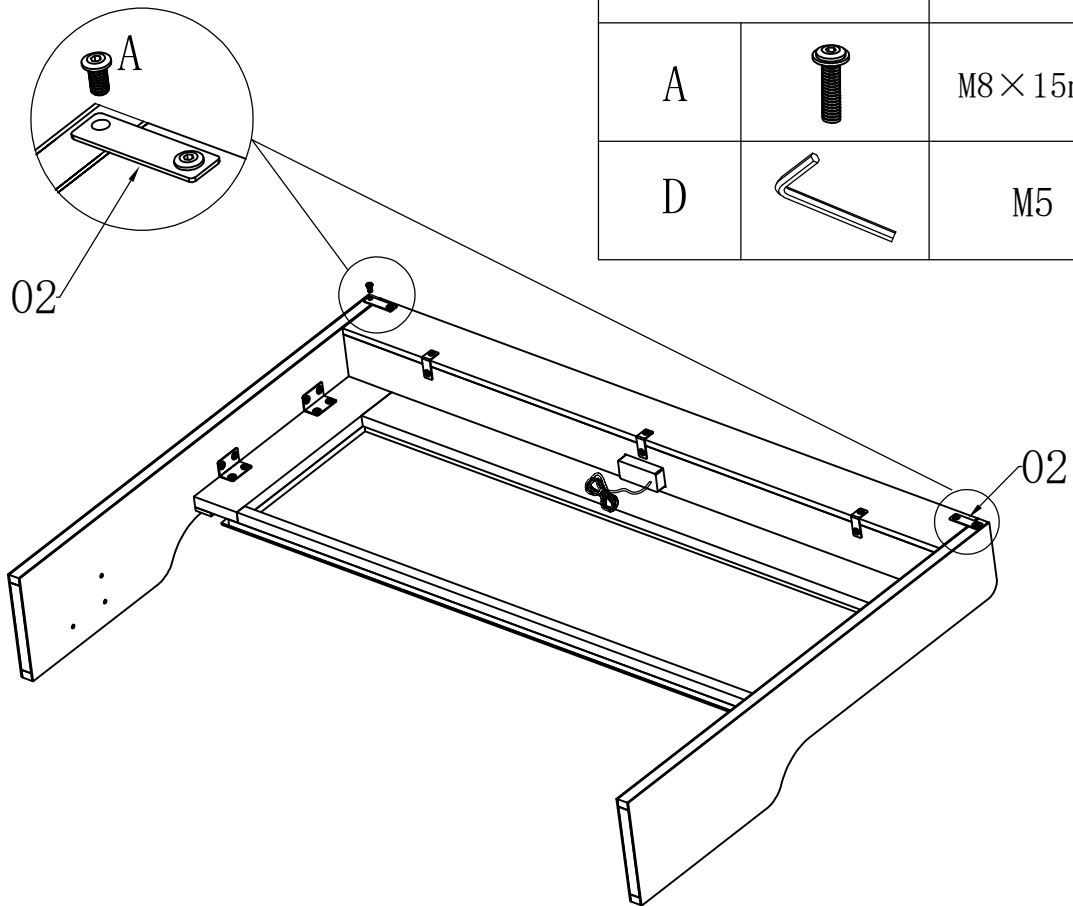
SCHRITT		Etapas5	
A		M8×15mm	4pcs
D		M5	1pc

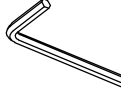

SCHRITT		Etapas6	
B		M8×35mm	4pcs
C		M8×60mm	2pcs
D		M5	1pc

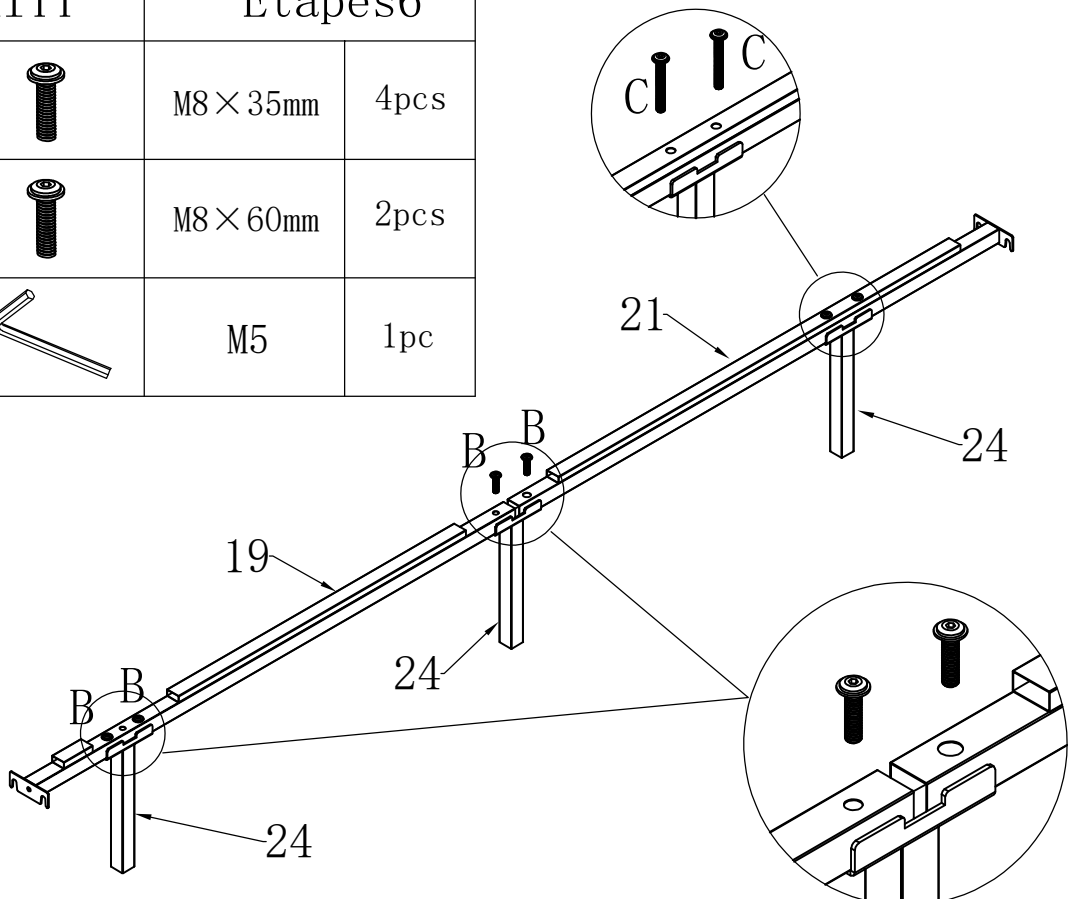

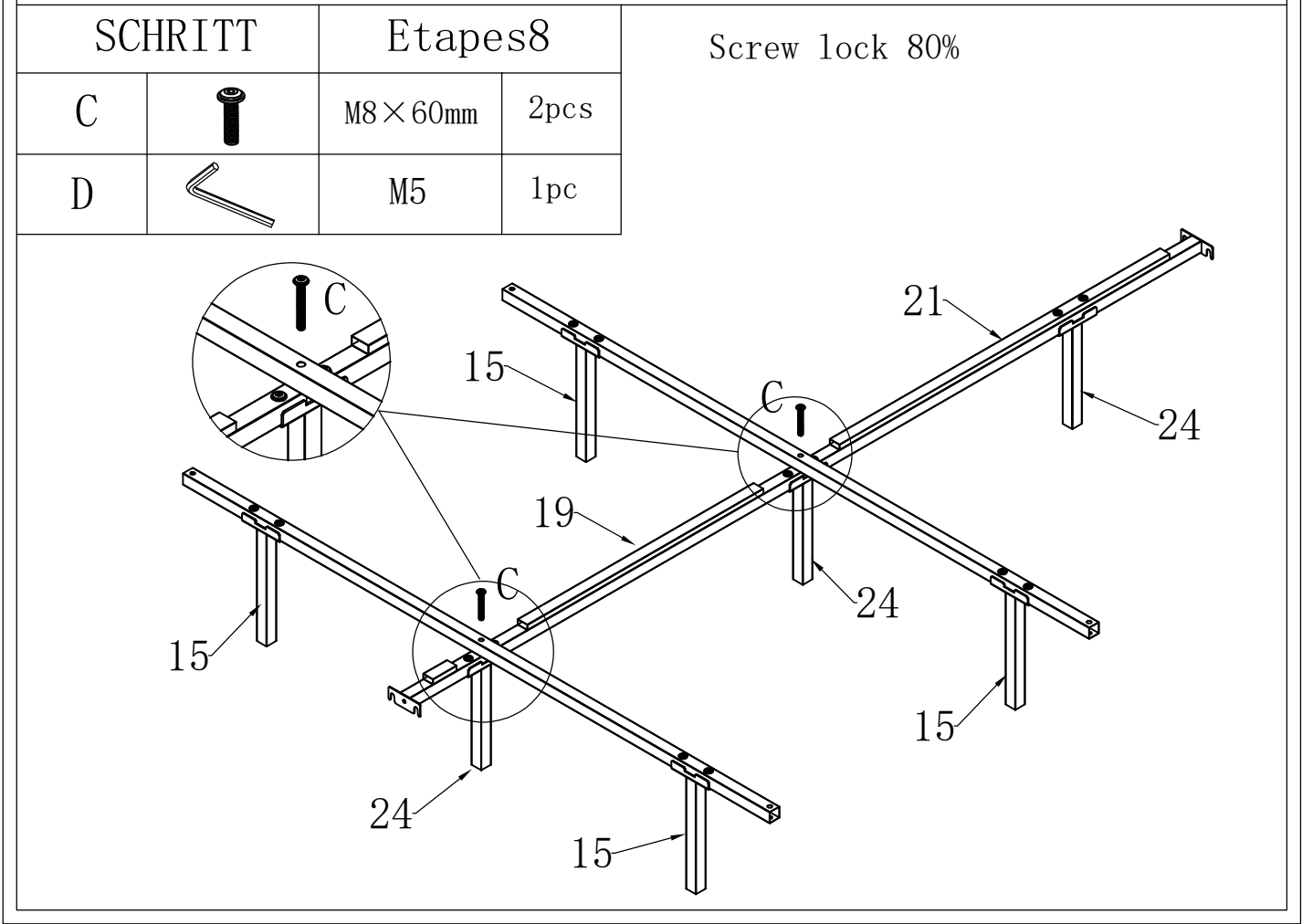
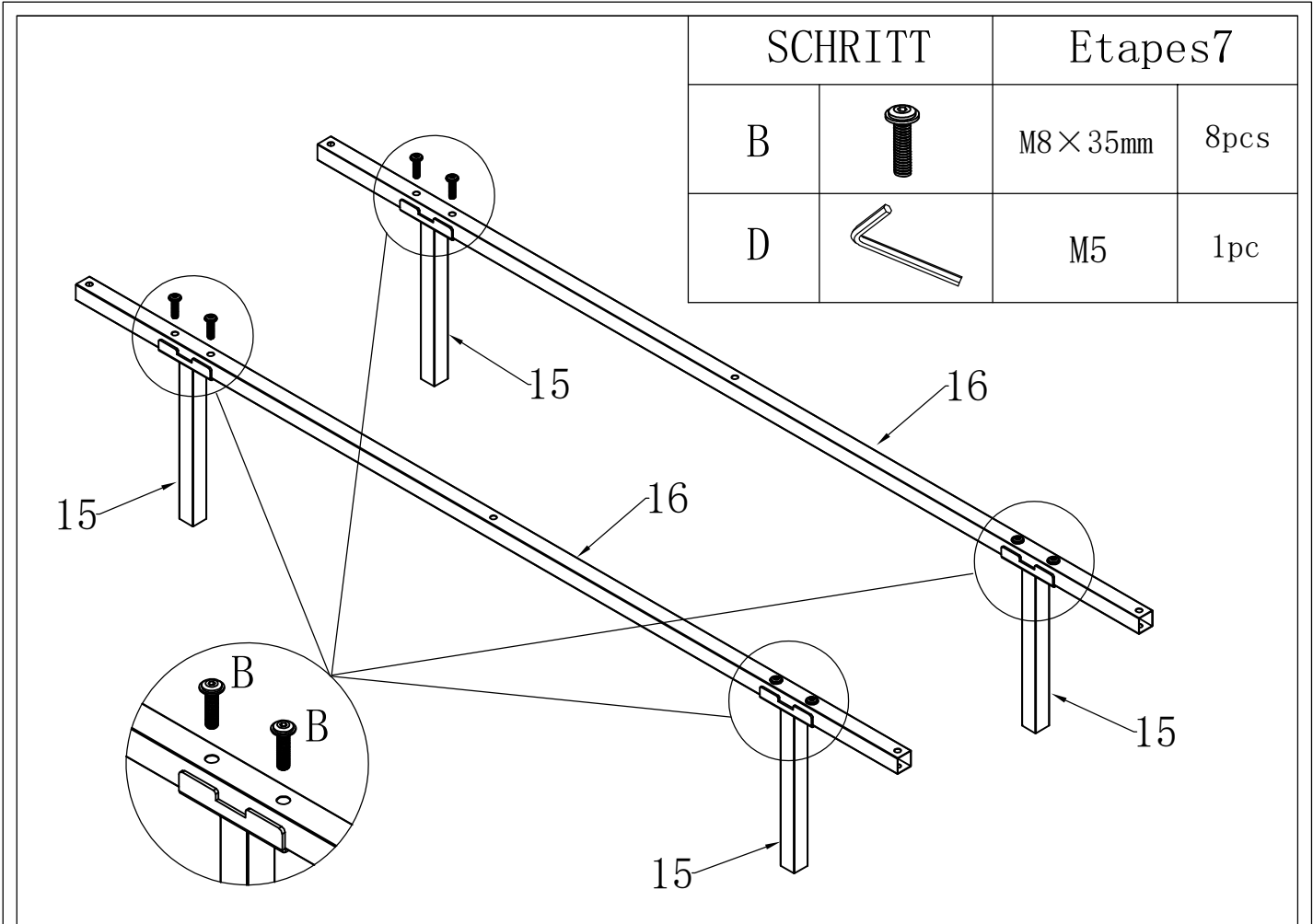

SCHRITT

Etapes9

A



M8 x 15mm

20pcs

D

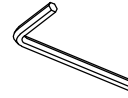

M5

1pc

Press the iron plate flat and then lock the screws 80%

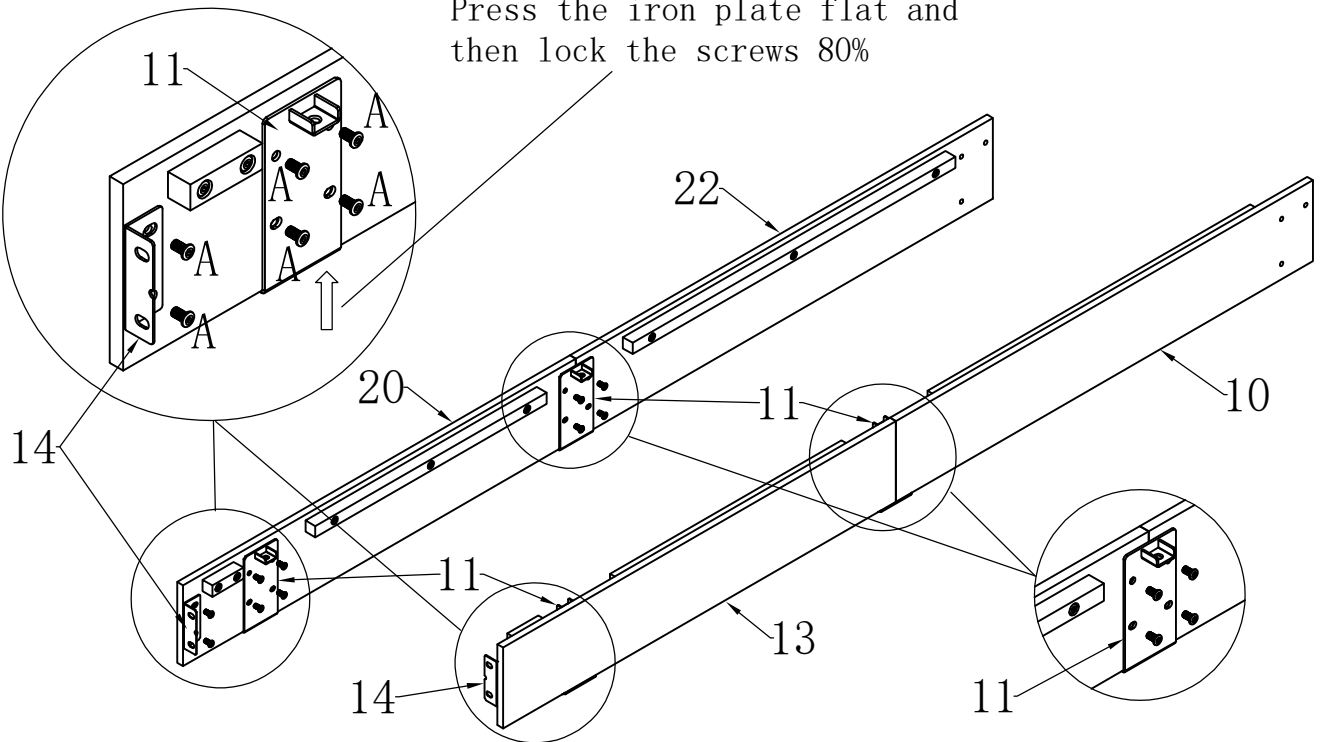

SCHRITT

Etapes10

B



M8 x 35mm

4pcs

D

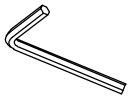

M5

1pc

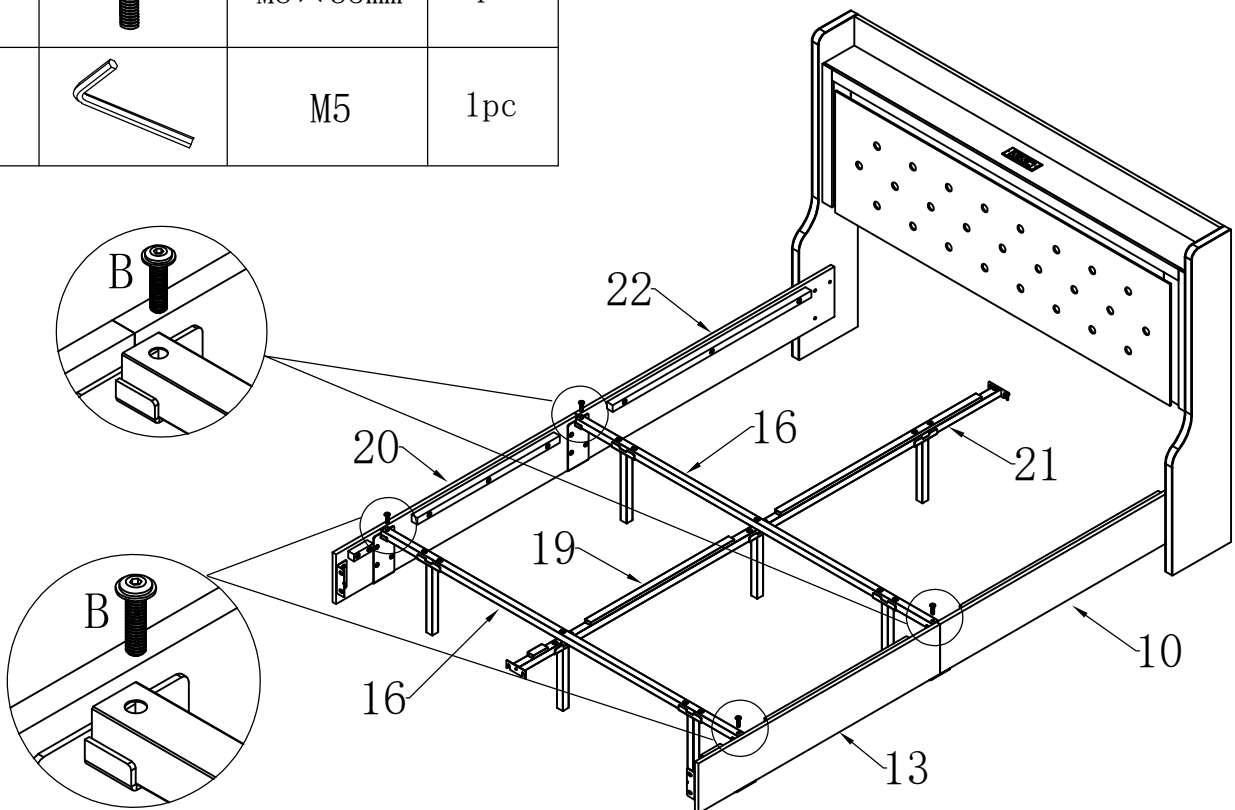

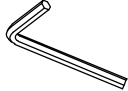
SCHRITT		Etapes11	
B		M8 × 35mm	2pcs
D		M5	1pc

Preinstall to 80% first

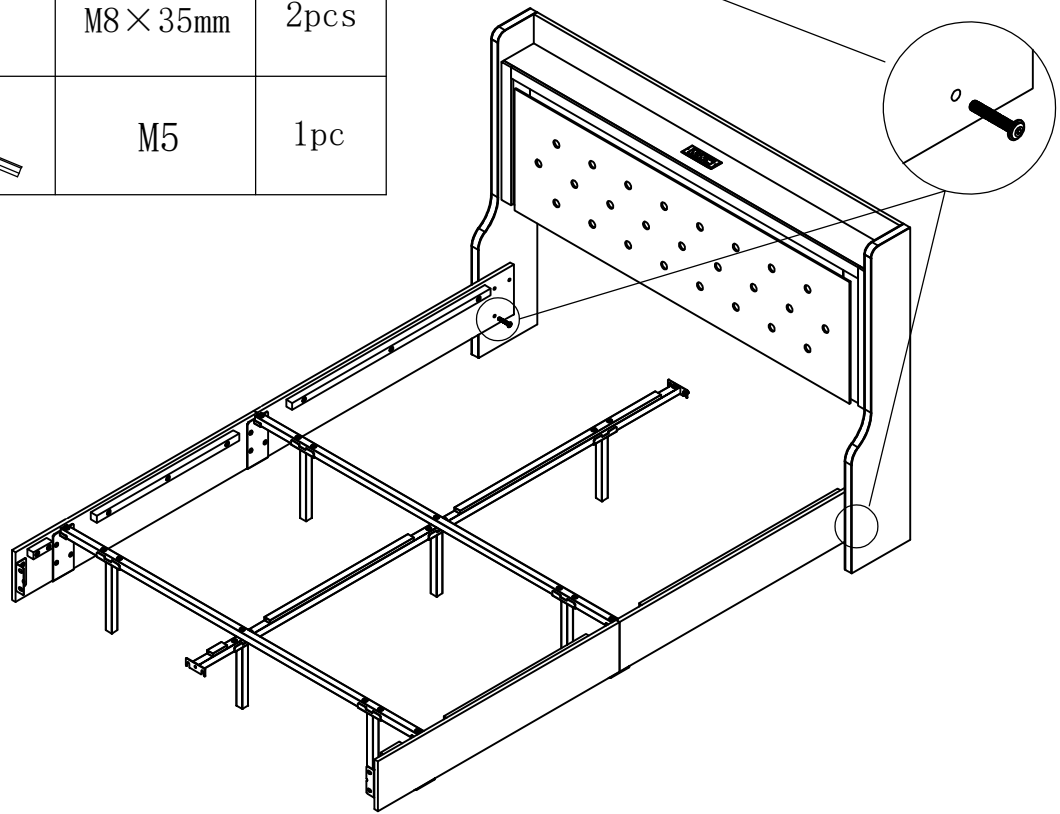

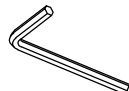

SCHRITT				Etapes12			
A		M8 × 15mm	4pcs	D		M5	1pc

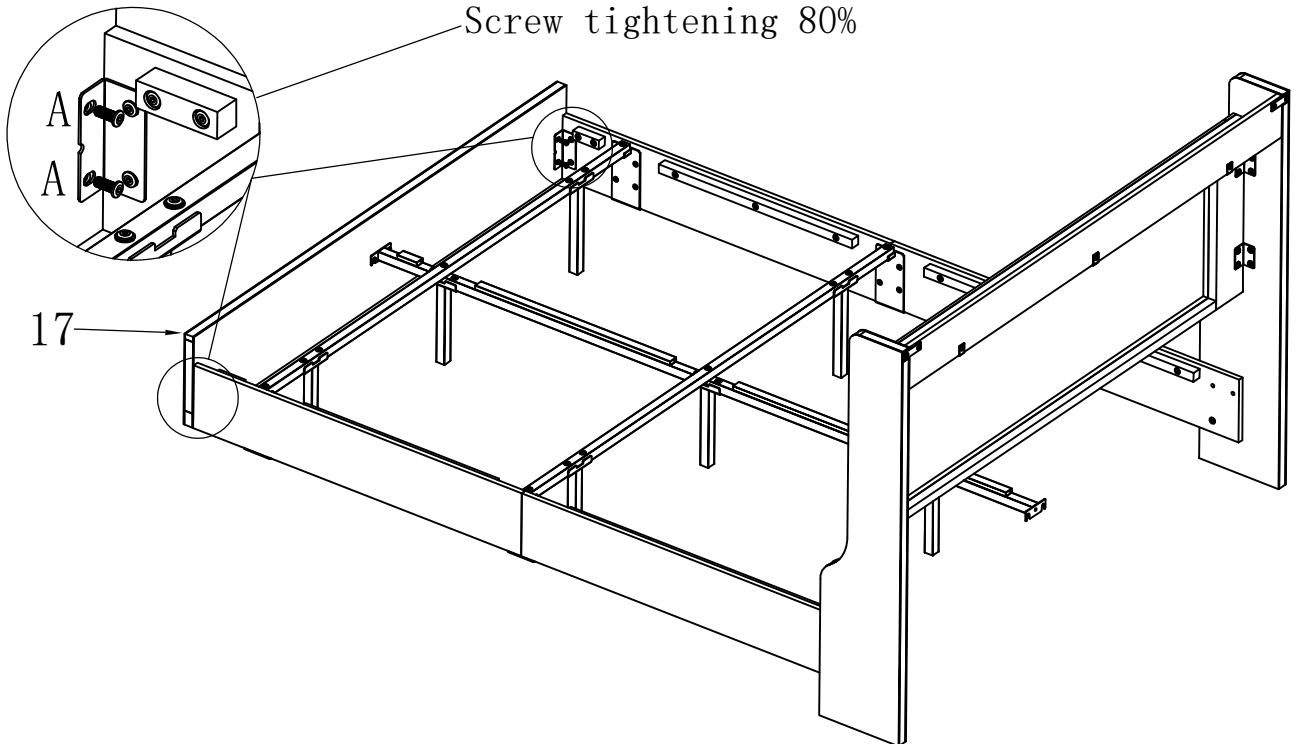
Screw tightening 80%



SCHRITT

Etapes13

A		M8 × 15mm	2pcs
B		M8 × 35mm	4pcs

D		M5	1pc
---	---	----	-----

Screw locks on both sides 50%;
next step locks the horizontal
bar hook.

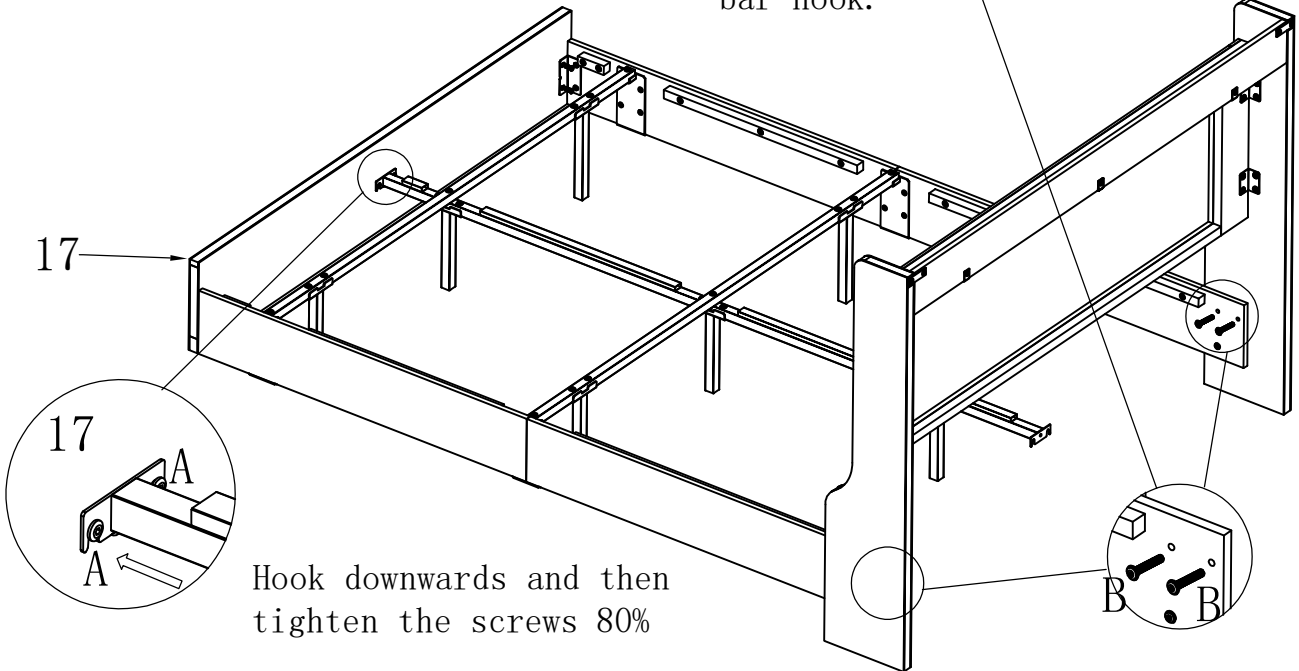

SCHRITT

Etapes14

D		M5	1pc
---	---	----	-----

Press the crossbar hook down and
then lock the screws 80%.

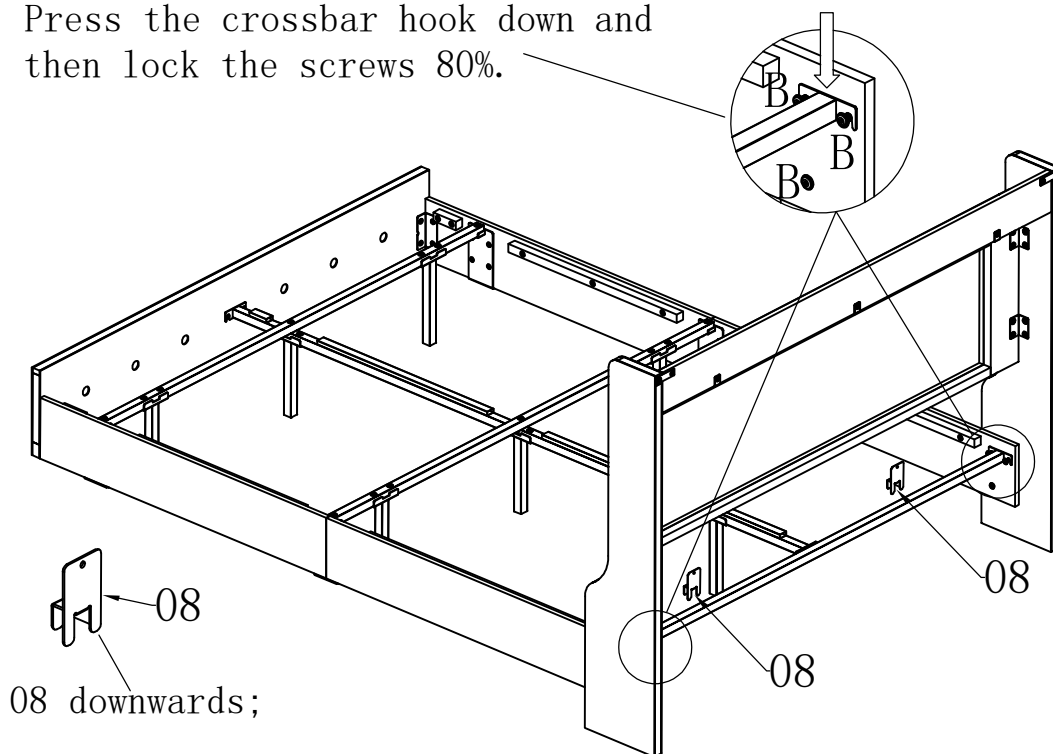

SCHRITT

Etapes15

A



M8 x 15mm

2pcs

D

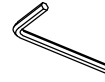

M5

1pc

Screw tightening 80%

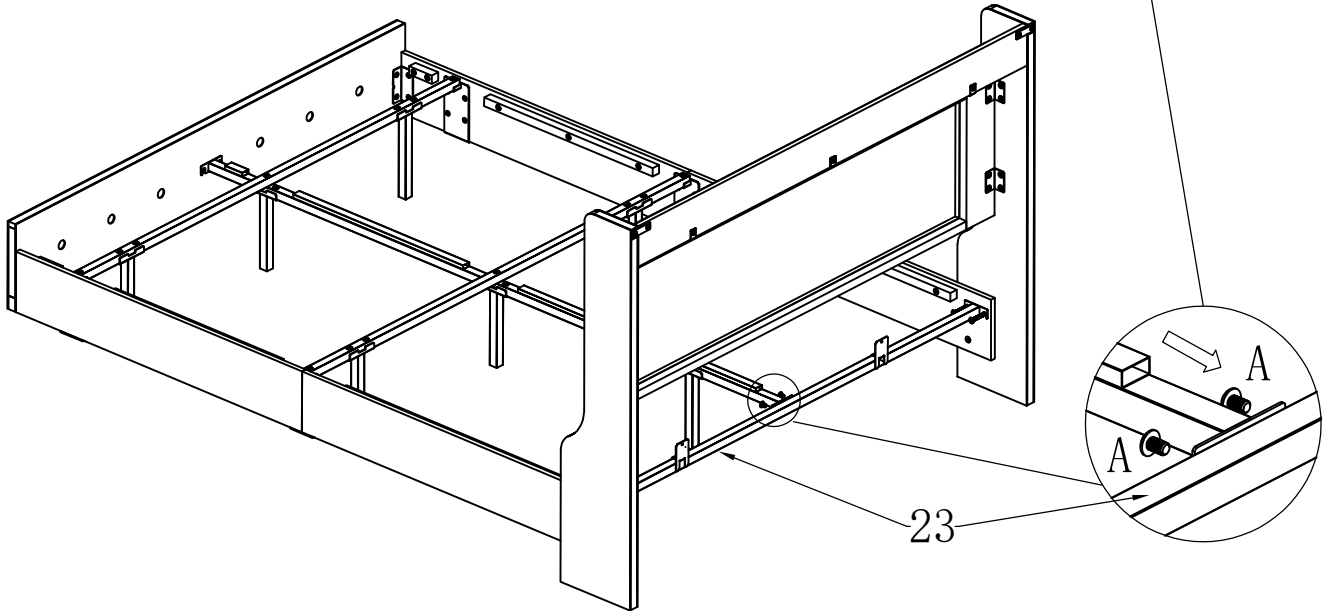

SCHRITT

Etapes16

All screws are 100% tightened;

