











End Table

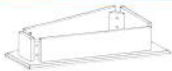

HARDWARE LIST

CODE	NAME	FIGURE	Q'TY
A	CAM LOCK (15*9mmL)		4PCS
B	CAM BOLT (6.5*35mmL)		4PCS
C	ALLEN SCREW (Ø1/4*45mmL)		8PCS
D	WASHER (Ø1/4*16mmL)		8PCS
E	LOCK WASHER (Ø1/4*11*1.5mmL)		8PCS
F	ALLEN WRENCH (4*21*57mmL)		1PC

PARTS LIST

CODE	NAME	FIGURE	Q'TY
1	TOP PANEL		1PC
2	BOTTOM PANEL		1PC
3	LEG		4PCS
4	COLOR STICK		1PC

STEP 1

HARDWARE	A x 4
NEEDED	B x 4

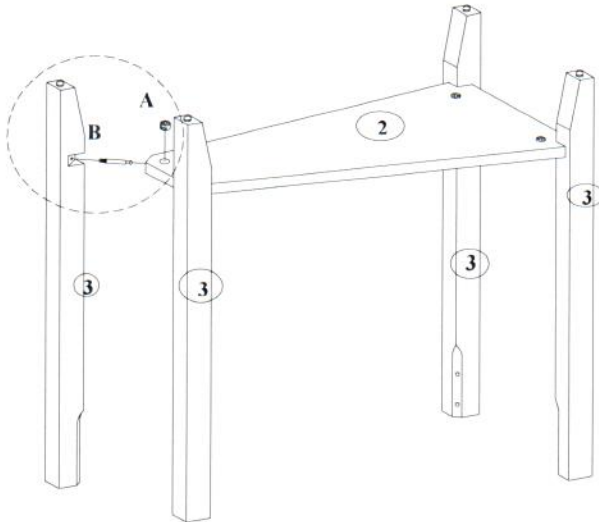

- 1.) Screw Cambolts (B) into Legs (3).
- 2.) Place Cam Locks (A) into Bottom Panel (2)
- 3.) Insert Legs into Bottom Panel and lock into position by turning Cam Locks clockwise.

***Turn only 1/4 of way for lock position.

****Arrow On Cam Lock
Faces Outward Opening

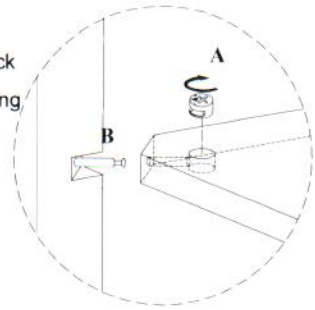

STEP 2

HARDWARE	C x 8
NEEDED	D x 8
	E x 8
	F x 1

- 1.) Place Leg Assembly onto Top Panel (1).
- 2.) Assemble Allen Screws (C) with Lock Washer (E) and Washer (D) in order as shown.
- 3.) Using Allen Wrench (F), fasten Allen Screw Assembly to secure the Top Panel to the Leg Assembly.

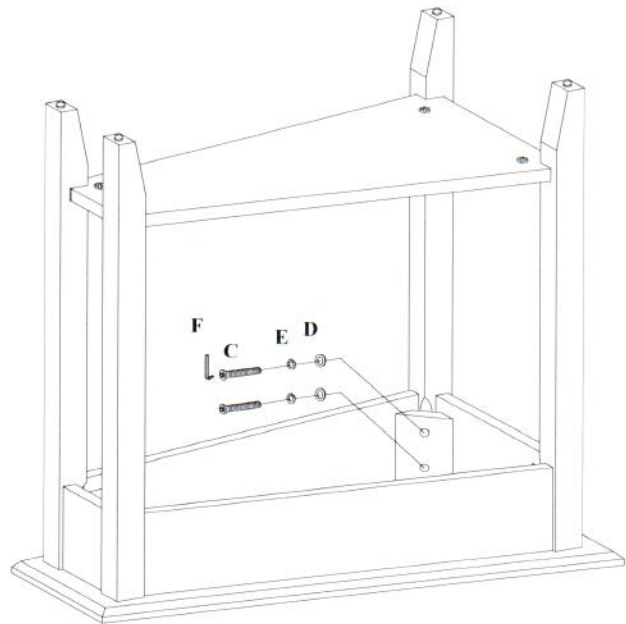

STEP 3

Turn Over and Enjoy your new quality piece of furniture for years to come!

