

## General Guidelines

- Please read the following instruction carefully and use the product accordingly.
- Please keep this manual and hand it over when you transfer the product.
- This summary may not include every detail of all variations and considered steps. Please contact us when further information and help are needed.

## Notes

- Please assemble the product strictly according to each step outlined in the instruction.
- During assembly, align all the screws with the corresponding pre-drilled holes first and then later tighten the screws one by one after placing all the parts in the correct places.
- Do not touch tube edges during assembly to avoid scratching your hands.
- Place the hallway rack on level ground during use, avoid placing next to high temperature fireplaces or under direct sunlight outdoors.
- For daily maintenance, wipe clean with a soft, damp cloth.
- Always use with anti-tipping device and do not hang heavy clothes on the top bar to avoid leaning. Children are forbidden to play on the rack to prevent falling or bodily injury.
- Warning - The product should be fixed to the wall by included anti-tipping device before use to avoid toppling over.

## Einleitung

- Bitte lesen Sie die folgende Anleitung aufmerksam durch und verwenden Sie das Produkt sachgemäß.
- Bewahren Sie diese Anleitung gut auf und händigen Sie sie bei Weitergabe des Produkts an Dritte ebenfalls mit aus.
- Aus Gründen der Übersicht können nicht alle Details zu allen Varianten und denkbaren Montagen beschrieben werden. Wenn Sie weitere Informationen und Hilfe benötigen, kontaktieren Sie uns bitte.

## Hinweise

- Bauen Sie den Kleiderständer bitte streng nach der Anleitung auf.
- Ziehen Sie alle Schrauben bitte nicht zu fest an. Erst fest anziehen, wenn die Montage fertig ist.
- Beim Zusammenbau gehen Sie bitte vorsichtig mit der Stangen um, um die Verletzungen durch scharfe Kanten zu vermeiden.
- Bitte stellen Sie den Kleiderständer auf eine horizontale Ebene und vermeiden Sie, den Ständer in der Nähe von Hitzequellen oder für eine lange Zeit unter direkter Sonneneinstrahlung zu stellen.
- Bei der Reinigung verwenden Sie bitte ein leicht feuchtes Tuch.
- Verwenden Sie das Produkt bitte mit dem Kippschutz und vermeiden Sie zu schwere Kleidung auf die obere Stange zu hängen. Lassen Sie keine Kinder auf den Kleiderständer klettern, ansonsten besteht Verletzungsgefahr!

- 
- Achtung - Um zu verhindern, dass der Kleiderständer umkippt, muss er mit dem beigegepackten Kippschutz fest an der Wand verankert werden.

FR

## Introduction

- Lisez attentivement ces instructions et utilisez votre produit d'après ce mode d'emploi.
- Conservez ces instructions. Si vous souhaitez offrir ce produit à un tiers, joignez obligatoirement ce mode d'emploi.
- Pour des raisons de clarté, les détails concernant chaque variante ou montage envisageable ne peuvent être tous décrits. Si vous souhaitez obtenir plus d'informations ou si vous rencontrez certains problèmes non traités de manière détaillée dans ces instructions, veuillez nous contacter.

## Notes

- Veuillez monter ce produit étape par étape d'après ce mode d'emploi.
- Lors du montage, veuillez bien positionner et régler toutes les vis et les écrous, ensuite effectuer un serrage progressif de l'ensemble des vis.
- Lors du montage, évitez tout contact avec les bords des tubes pour ne pas vous blesser.
- Mettez ce produit sur un sol plat à l'abri de la chaleur. N'exposez pas ce produit à l'extérieur et aux rayons du soleil forts à l'extérieur.
- Pour l'entretien du produit, il est conseillé de nettoyer avec un chiffon humide.
- Veuillez mettre en place le système anti-basculement. Veuillez ne pas pendre des vêtements trop lourds sur les barres au niveau supérieur, sinon, le produit pourrait perdre son équilibre et se renverser. Pour éviter des accidents, il est interdit aux enfants de jouer avec ce produit.
- Attention - Pour éviter le risque de basculement, il est impératif de fixer ce produit au mur via le ruban anti-basculement fourni.

IT

## Linee guida generali

- Si prega di leggere attentamente le seguenti istruzioni e usare il prodotto in modo opportuno.
- Si prega di conservare questo manuale e consegnarlo quando il prodotto cambia proprietario.
- Questo riassunto potrebbe non includere ogni dettaglio di tutte le variazioni e le fasi considerate. Contattaci se hai bisogno di ulteriori informazioni e assistenza.

## Note

- Si prega di eseguire il montaggio seguendo attentamente le istruzioni.
- In fase di montaggio, si prega di non stringere le viti quando inserite nei fori, ma di avvitarle soltanto alla fine, dopo aver completato il montaggio.
- Non toccare i fori dei tubi direttamente con le mani al fine di evitare il rischio di lesioni.
- Collocare il prodotto su una superficie orizzontale, non esporre il prodotto alla luce solare diretta o vicino a fonti

- 
- 
- di calore.
- Si può strofinare il prodotto con un panno umido per pulirlo.
  - Montare l'attacco anti-ribaltamento e fissarlo alla parete prima dell'uso. Non appendere gli abiti pesanti alla barra più alta per evitare inclinazione causata dallo sbilanciamento. Proibire ai bambini di giocare sul prodotto per prevenire le cadute.
  - Avvertenza - Per garantire la sicurezza ed evitare il ribaltamento durante l'uso, montare l'attacco anti-ribaltamento e fissarlo alla parete.









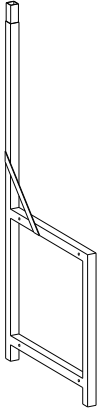
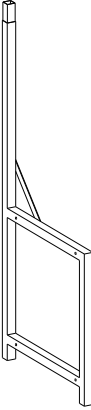
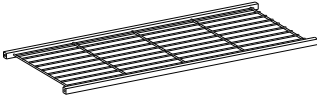
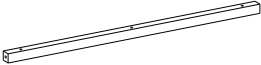
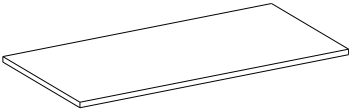
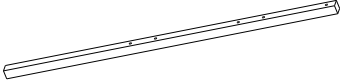

## Acerca del manual

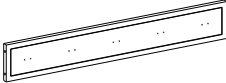
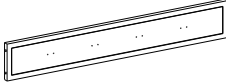
- Por favor, lea detenidamente las instrucciones y respete los debidos usos del producto.
- Por favor, conserve bien este manual y en caso de cesión, no olvide entregarlo junto al producto.
- No es posible que presente todos los detalles y los pasos de montaje en las instrucciones. Si necesita ayuda o información adicional, póngase en contacto con nosotros.

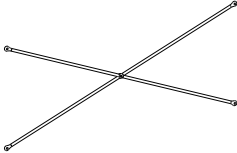
## Notas

- Debe montar el producto paso a paso siguiendo las instrucciones.
- No apriete totalmente los tornillos durante el montaje, después de terminar el montaje, apriete por completo todos los tornillos.
- Está prohibido el contacto directo con los bordes de los tubos para evitar las rayas.
- Utilice el producto en un suelo nivelado y manténgalo alejado de chimenea. No lo deje expuesto al sol.
- Use una toalla mojada para la limpieza diaria.
- Al usar el producto, debe montar el mecanismo de seguridad. No cuelgue las prendas que tengan un peso extremo en la barra superior para prevenir la inclinación. No permita que los niños jueguen con el producto para evitar las lesiones causadas por la caída.
- Advertencia - Antes del uso, ha de montarse el mecanismo de seguridad suministrado a la pared para evitar la caída.

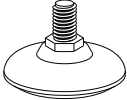
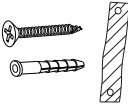
<p><b>A</b> <span style="float: right;">× 1</span></p> 	<p><b>B</b> <span style="float: right;">× 1</span></p> 
<p><b>C</b> <span style="float: right;">× 1</span></p> 	<p><b>D</b> <span style="float: right;">× 2</span></p> 
<p><b>E</b> <span style="float: right;">× 1</span></p> 	<p><b>F</b> <span style="float: right;">× 2</span></p> 

<p><b>G</b> × 1</p> 	<p><b>H</b> × 1</p> 	<p><b>I</b> × 9</p> 
<p><b>J</b> × 1</p> 	<p><b>K</b> × 1</p> 	<p><b>L</b> × 8</p>  <p><b>M6 × 40 mm</b></p>
<p><b>M</b> × 16</p>  <p><b>M6 × 35 mm</b></p>	<p><b>N</b> × 8</p> 	<p><b>O</b> × 4</p> 
<p><b>P</b> × 1</p> 	<p><b>Q</b> × 18</p> 	<p><b>R</b> × 1</p> 

1

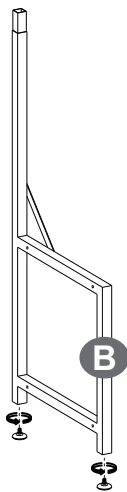
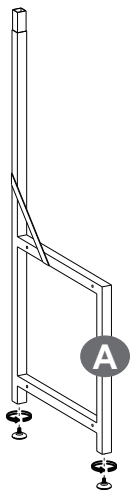
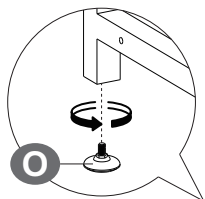

2

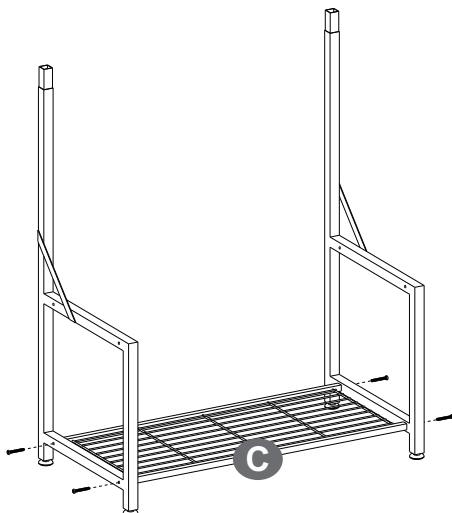
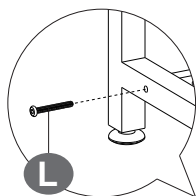

3

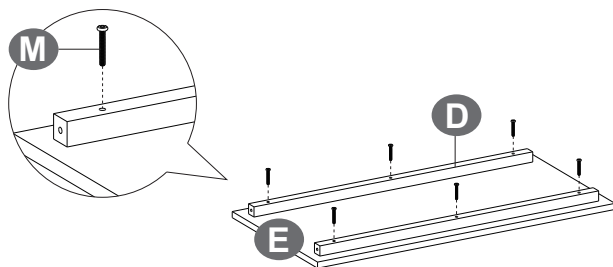

**M**



6PCS

4

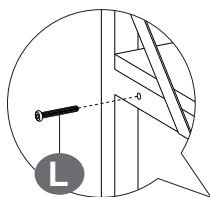

**L**

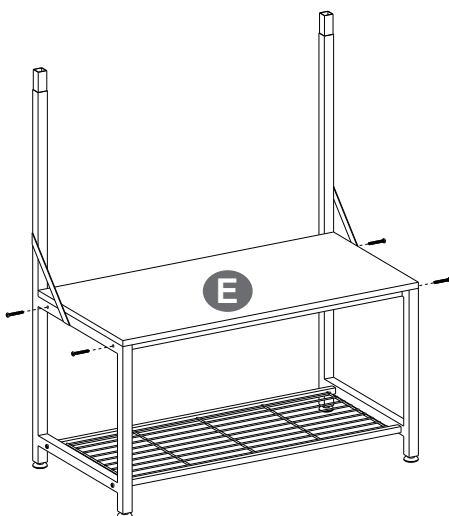



**L**

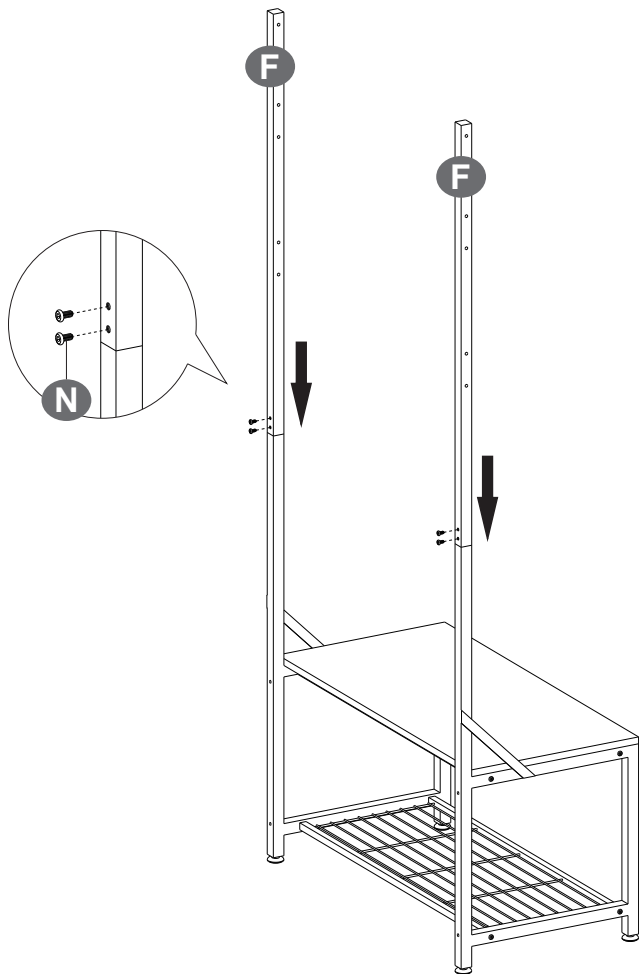

4PCS

5



**N**  4PCS

6

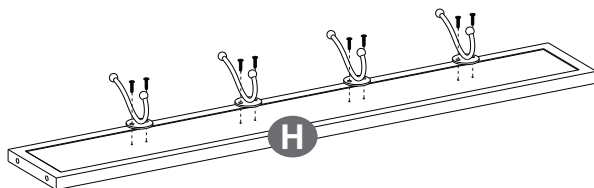
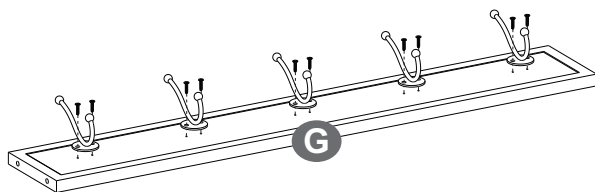
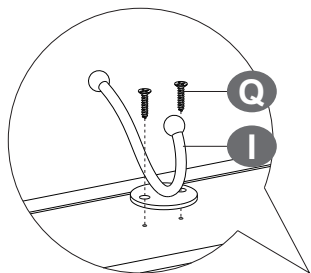

7

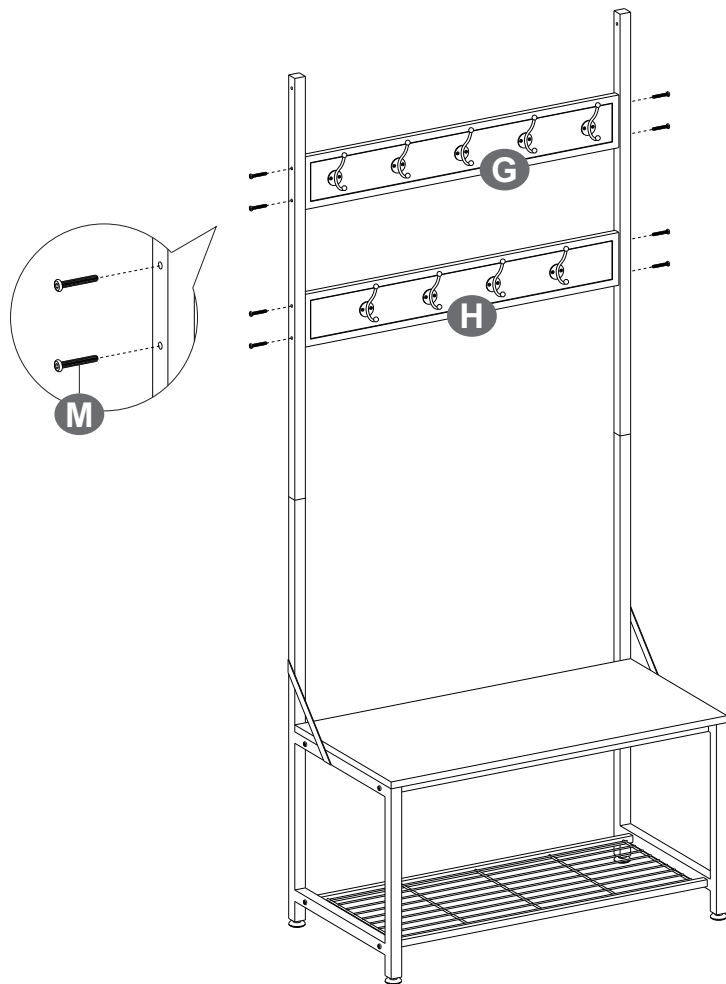

**M**  8PCS

8

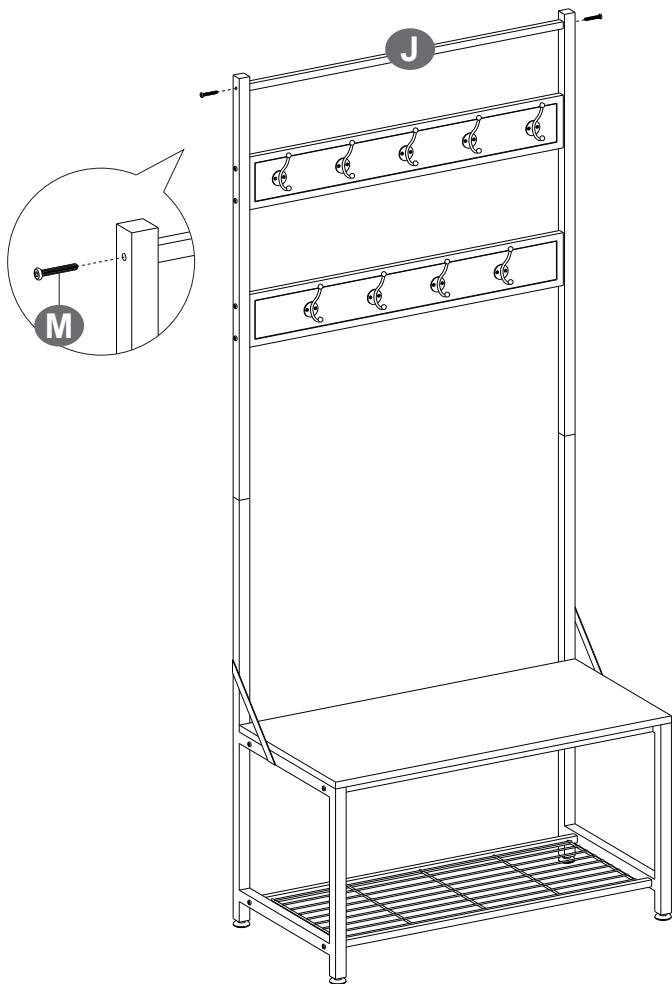

**M**  2PCS

9

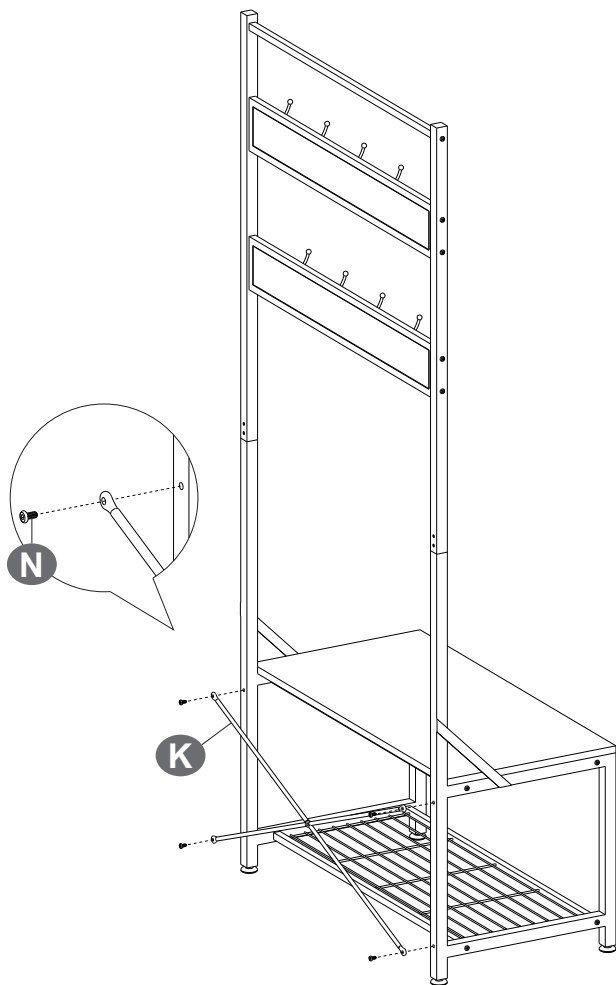

**N**  4PCS

10

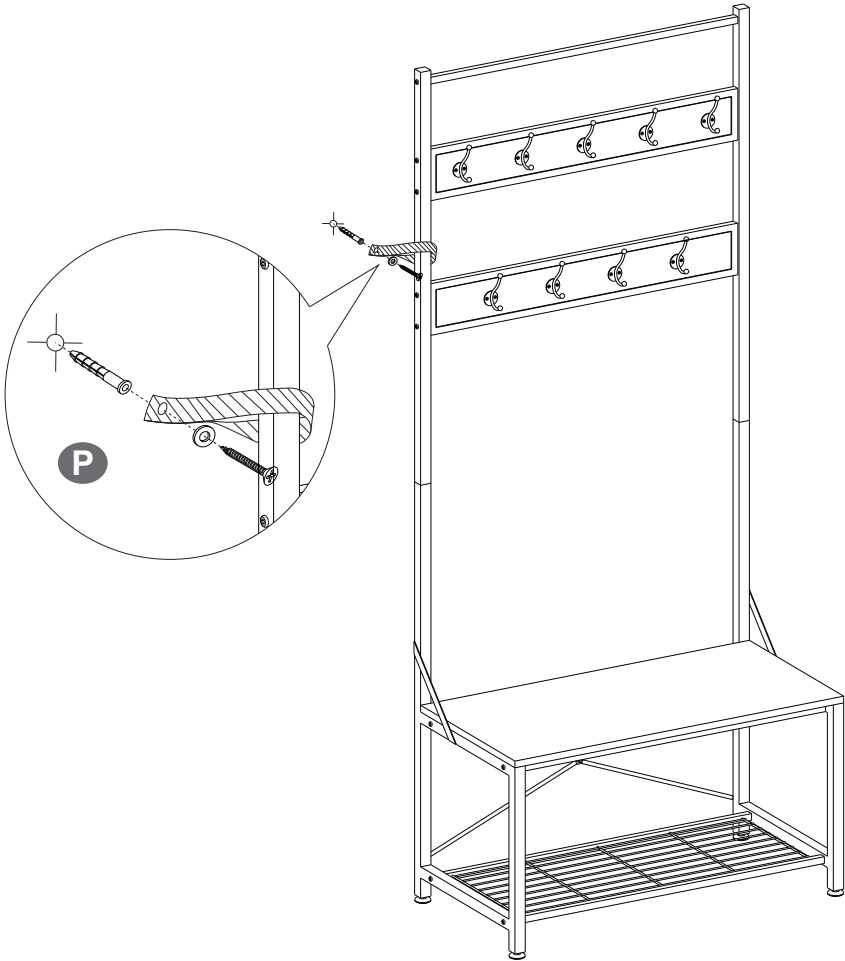

**P**  1PC