

ASSEMBLY INSTRUCTIONS

ASSEMBLY
REQUIREMENTS:

1-Person
Assembly

30 Minutes
Assembly Time Per Chair
(Approximate)

Thank you for purchasing our product!

Please refer and use this assembly instruction to assemble the product. Contact our customer service department in case there are any missing or damage parts or hardware. Replacement parts are normally shipped within 2 or 3 days.

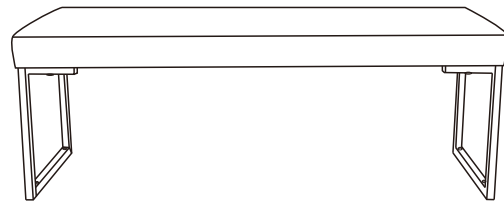

ASSEMBLY PREPARATION

1. Remove all packaging materials, staples and packing straps from the carton.
2. Refer to Parts List and Hardware List, and ensure parts and hardware are correct before assembly. Contact customer service for missing parts.
3. Place all wooden parts on a clean, flat and soft surface (e.g. carpet or rug) to prevent scratch and damage to parts.

SAFETY PRECAUTION

1. KEEP ALL HARDWARE PARTS OUT OF REACH OF CHILDREN.
2. DISPOSE PLASTIC PACKAGING MATERIAL IMMEDIATELY TO AVOID ANY RISK OF SUFFOCATION TO CHILDREN AND ANIMALS.

TIPS FOR ASSEMBLY

1. Allow ample room for assembly and assemble the product near where the product will be placed.
2. Assemble the product on a surface that does not scratch or damage the exterior gloss and finish of the furniture.
3. Identify all of the parts, hardware and quantities required for each step.
4. During assembly, do not over-tighten any fittings as this may cause damage.
5. DO NOT USE POWER TOOLS TO ASSEMBLE THIS PRODUCT.
6. Always place the product on a flat, level surface.
7. Do not sit or stand on the partially assembled product; only use the product for which it is intended.

CARE AND MAINTENANCE

- Use a slightly damp cloth to clean the product. Do not use bleach or abrasive cleaning material.
- Check all the fittings periodically and re-tighten as necessary. Do not use the product if any of the parts is damaged or broken.
- Never allow any kind of liquid to remain on your furniture. Absorption can cause wood to warp or delaminate.
- Do not place hot items (e.g. hot drinks) directly onto the wood surface.
- Do not drag and/or pull the furniture.

This product is for indoor and household use only - not for commercial use.

Hardware

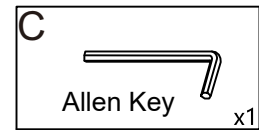
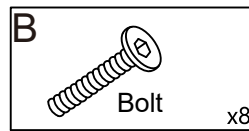
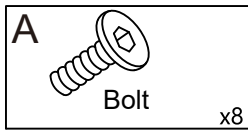

Parts

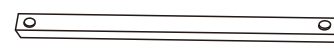
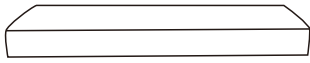

STEP 1

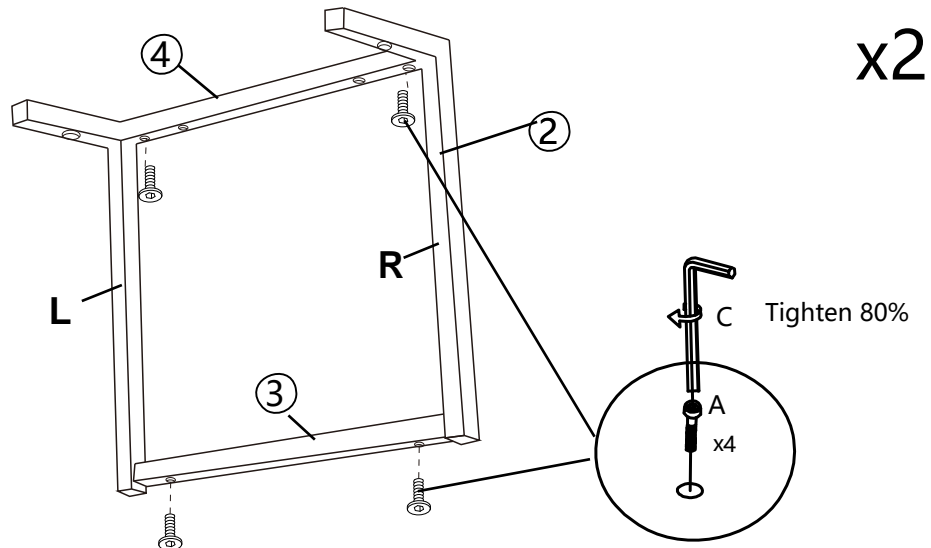

- Attach Top and Bottom Connect Bar (4 & 3) to the 2 pieces of Leg (2) as shown and fasten with Bolt (A).
- Use Allen Key (C) to drive (A). Do not tighten (A) fully (only 80%) at this time.
- Assemble the second leg assembly using the above procedures.

STEP 2

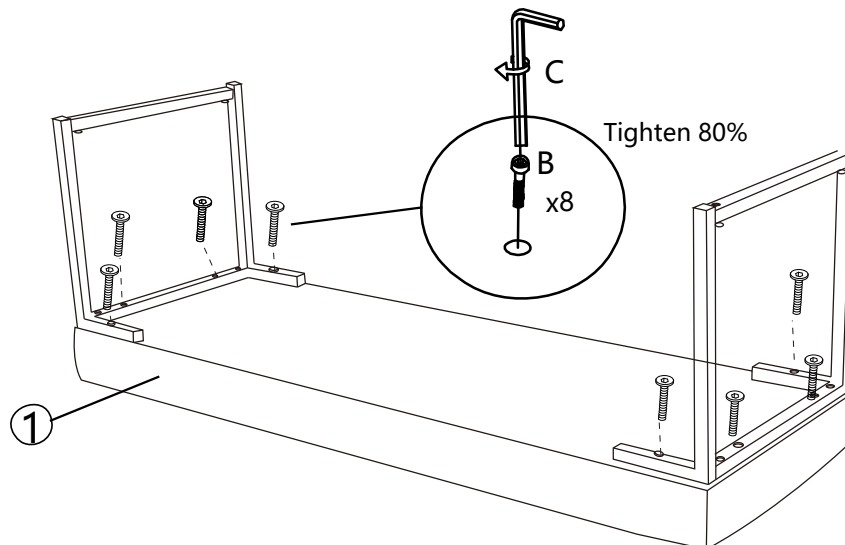

- Lay Seat (1) bottom-side up as shown on a material that does not scratch its surface.
- Position the Leg assembly from STEP 1 with bolt holes aligned to the bolt holes on the bench seat.
- Use Bolt (B) to fasten Leg to Seat. Use Allen Key (C) to drive (B). Do not tighten (B) completely (quarter turn loose) at this time.



Note: Please leave all the screws a-quarter-turn loose before all parts are set. Fully tighten them to finish the assembly.

STEP 3

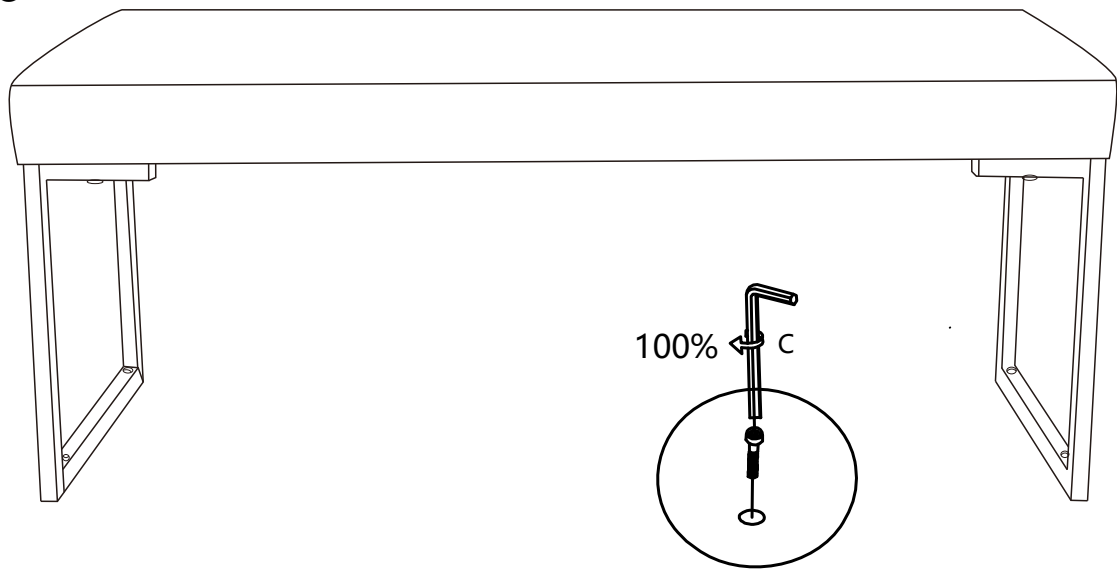

A. Set the bench right-side up and check that the bench is level and balanced and then tighten all the Bolts (A & B).



Set the bench right-side up on flat, level floor and check to ensure the legs are flat and in contact with the flat, level floor and then tighten all of the Bolts (A & B) in STEP 3 and 2.

STEP 4

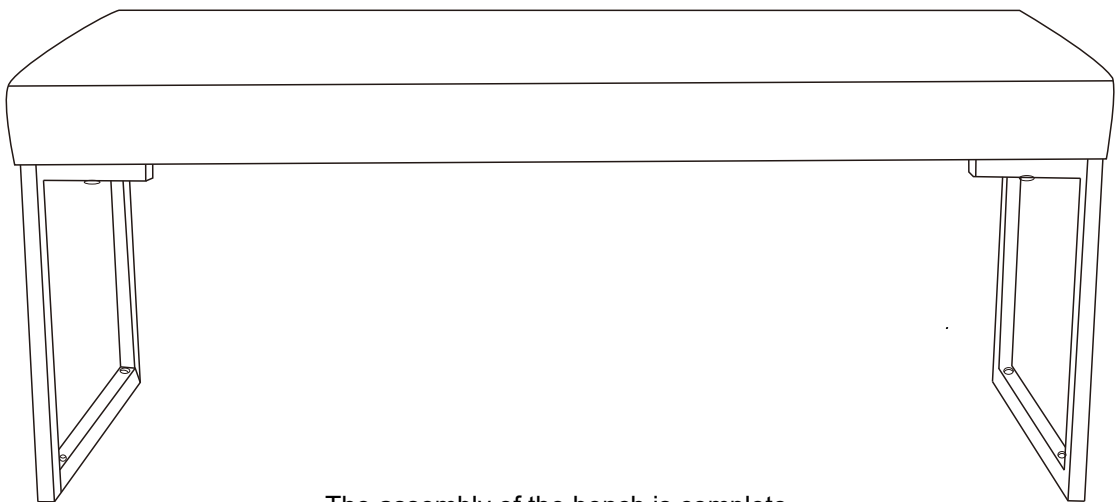

The assembly of the bench is complete.

Note: As the bench gets acclimated to its new environment, check and tighten all the bolts after a few days.