

Installation & Assembly

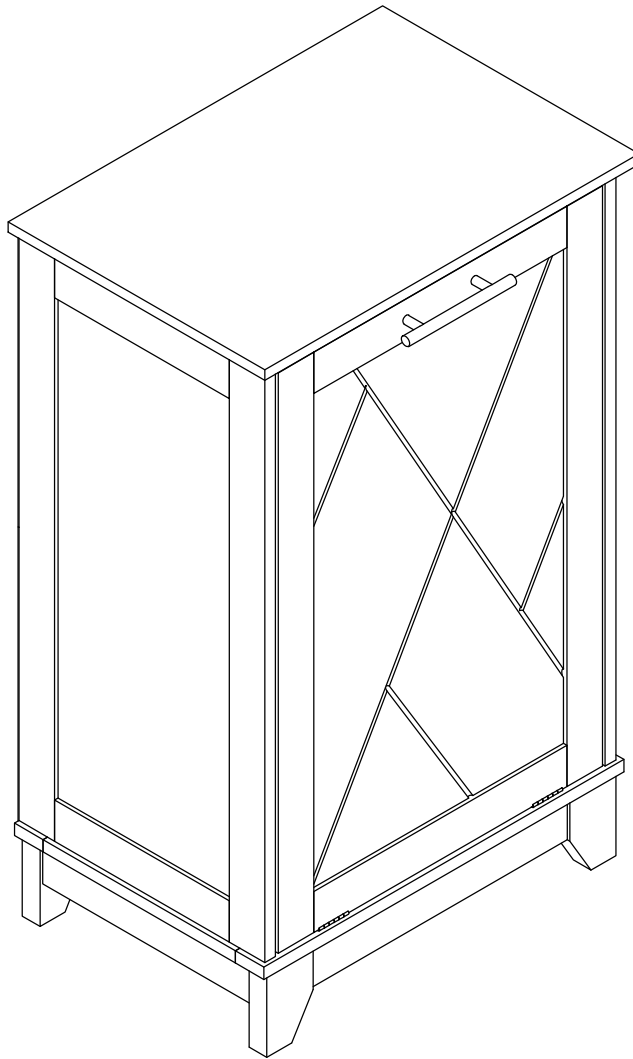
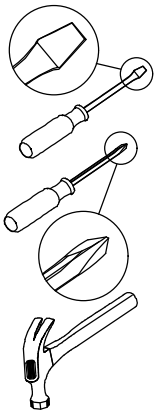

As this item contains many parts, please read the installation instruction carefully before installation . Please use tools properly and carefully. If you have any questions about the product and installation, please contact us.

Our professional after-sales team will serve you online all day.

Before You Start



- ✓ Read through each step carefully and follow the proper order
- ✓ Separate and count all your parts and hardware
- ✓ Give yourself enough room for the assembly process
- ✓ Have the following tools: Flat Head Screwdriver, #2 Phillips Head Screwdriver and Hammer
- ✓ Caution: If using a power drill or power screwdriver for screwing, please be aware of to slow down and stop when screw is tight. Failure to do so may result in stripping the screw. (Assembly speed can be increased by using electric screwdriver)

Helpful Hints

PEOPLE NEEDED FOR ASSEMBLY: 1-2

- Open your item in the area you plan to keep it to avoid excessive heavy lifting.
- Identify, sort and count the parts before attempting assembly.
- Compression dowels are lightly tapped in with a hammer.
- Slides are labeled with an **R** (right) and **L** (left) for proper placement.
- Make sure to always face the point on the top of the Cam Lock towards the outer edge.
- If there is a back panel in the package, please install it to make sure your unit is complete and sturdy.
- Please fix all the screws provided for the back panel which can enhance product stability. If it is difficult to fix it when tightening, it can be fixed with the help of a hammer and then tightened.
- Do NOT use harsh chemicals or abrasive cleaners on this item.
- Never push, pull, or drag your furniture.



Board Identification

Not actual size

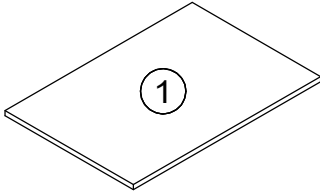

DESKTOP
Qty:1

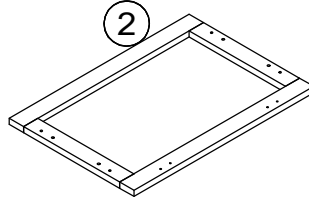

MOTHERBOARD
Qty:1

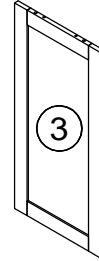

LEFT PANEL
Qty:1

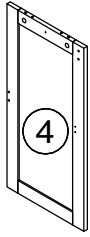

RIGHT PANEL
Qty:1

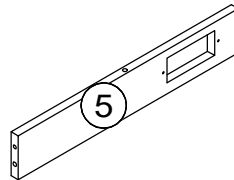

UPPER HORIZONTAL BAR
Qty:1

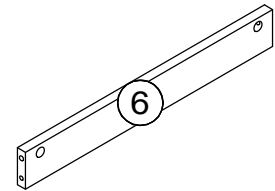

MIDDLE AND REAR BARS
Qty:1

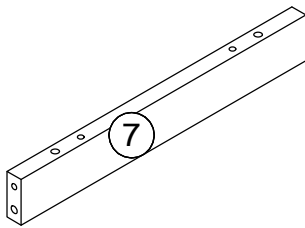

FRONT AND REAR STANDING
WATER HORIZONTAL BARS
Qty:2

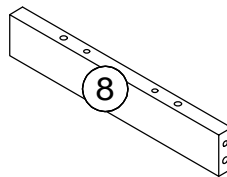

LEFT AND RIGHT STANDING
WATER HORIZONTAL BARS
Qty:2

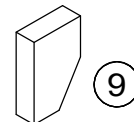

STANDING WATER
WOOD FOOT 1
Qty:2

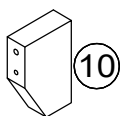

STANDING WATER
WOOD FOOT 2
Qty:2

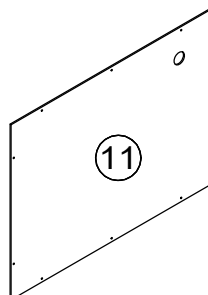

UPPER BACK PLATE
Qty:1

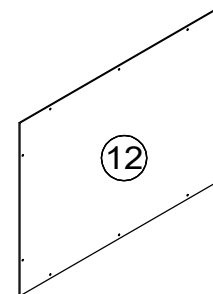

LOWER BACK PANEL
Qty:1

Board Identification

Not actual size

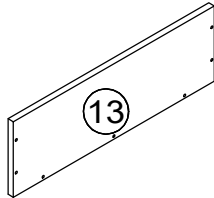

DRAWER BACK PANEL
Qty:1

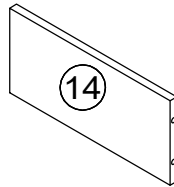

DRAWER LEFT PANEL
Qty:1

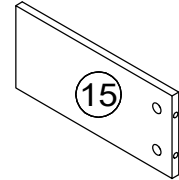

RIGHT PANEL OF
DRAWER
Qty:1

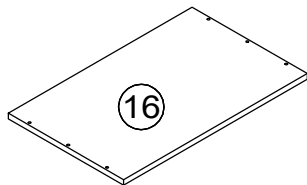

DRAWER BOTTOM
PANEL
Qty:1

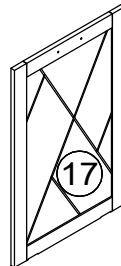

DRAWER PANEL
Qty:1

Part List

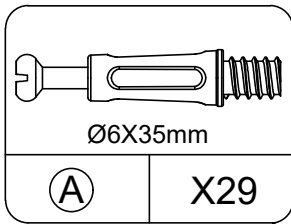

CAM BOLT
spare:2

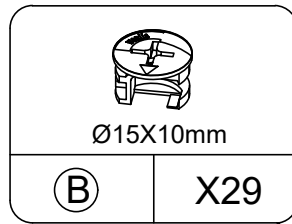

CAM LOCK
spare:2

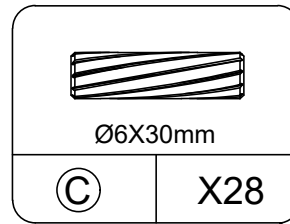

WOOD DOWEL
spare:2

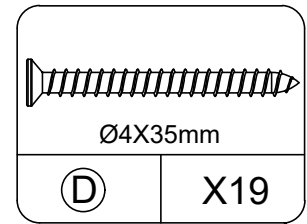

SCREW
spare:2

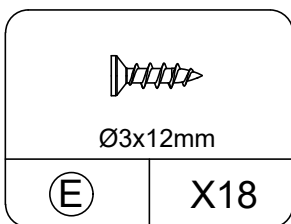

SCREW
spare:2

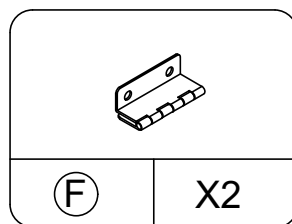

4-HOLE 3-PAGE HINGE

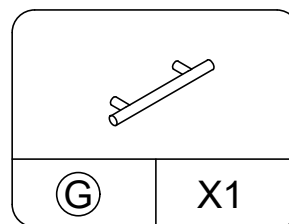

HANDLE

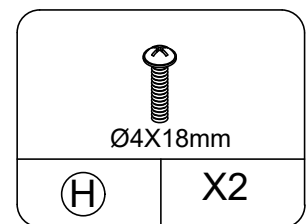

SCREW

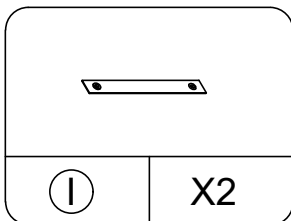

ANTI-INVERTED
STRIPS

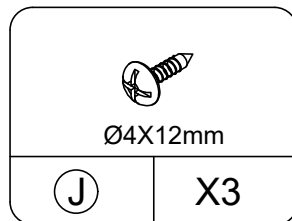

SCREW

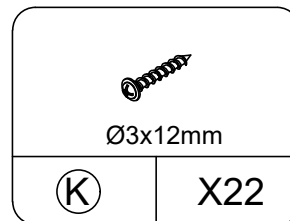

SCREW

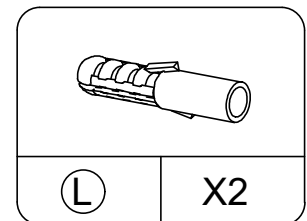

SLIDE EXPANSION BOLTS

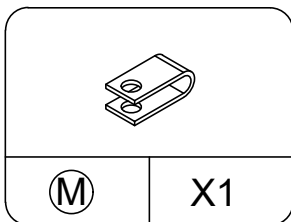

WIRE BUCKLE

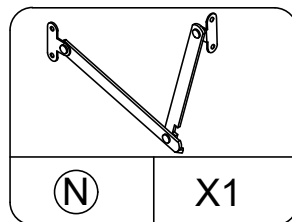

METAL PULL RODS

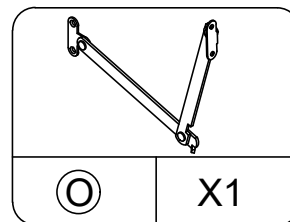

METAL PULL RODS

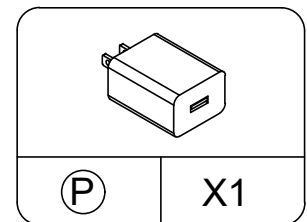

PLUG

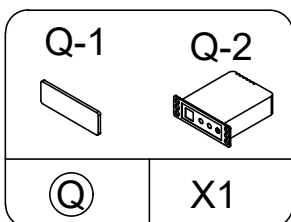

DECONTAMINATION

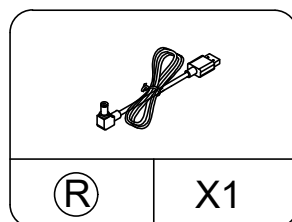

ELECTRIC WIRE

Part List

Cam Lock Fastening System

Insert the cam bolt into the hole first, then insert the cam lock and lock it.

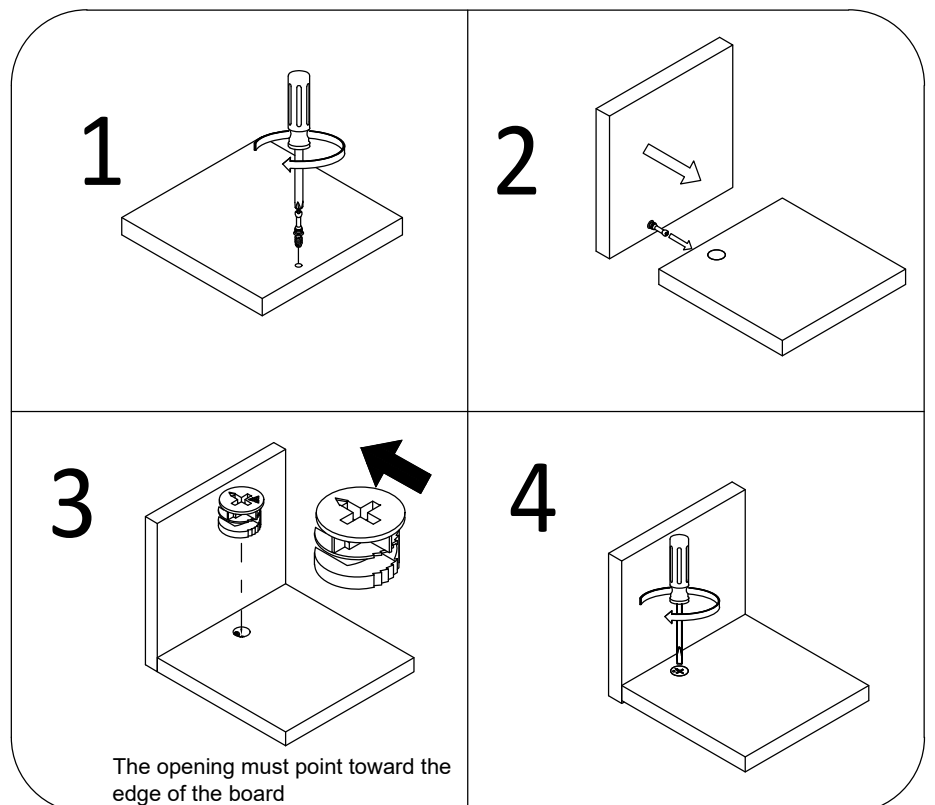

Board Identification

Not actual size

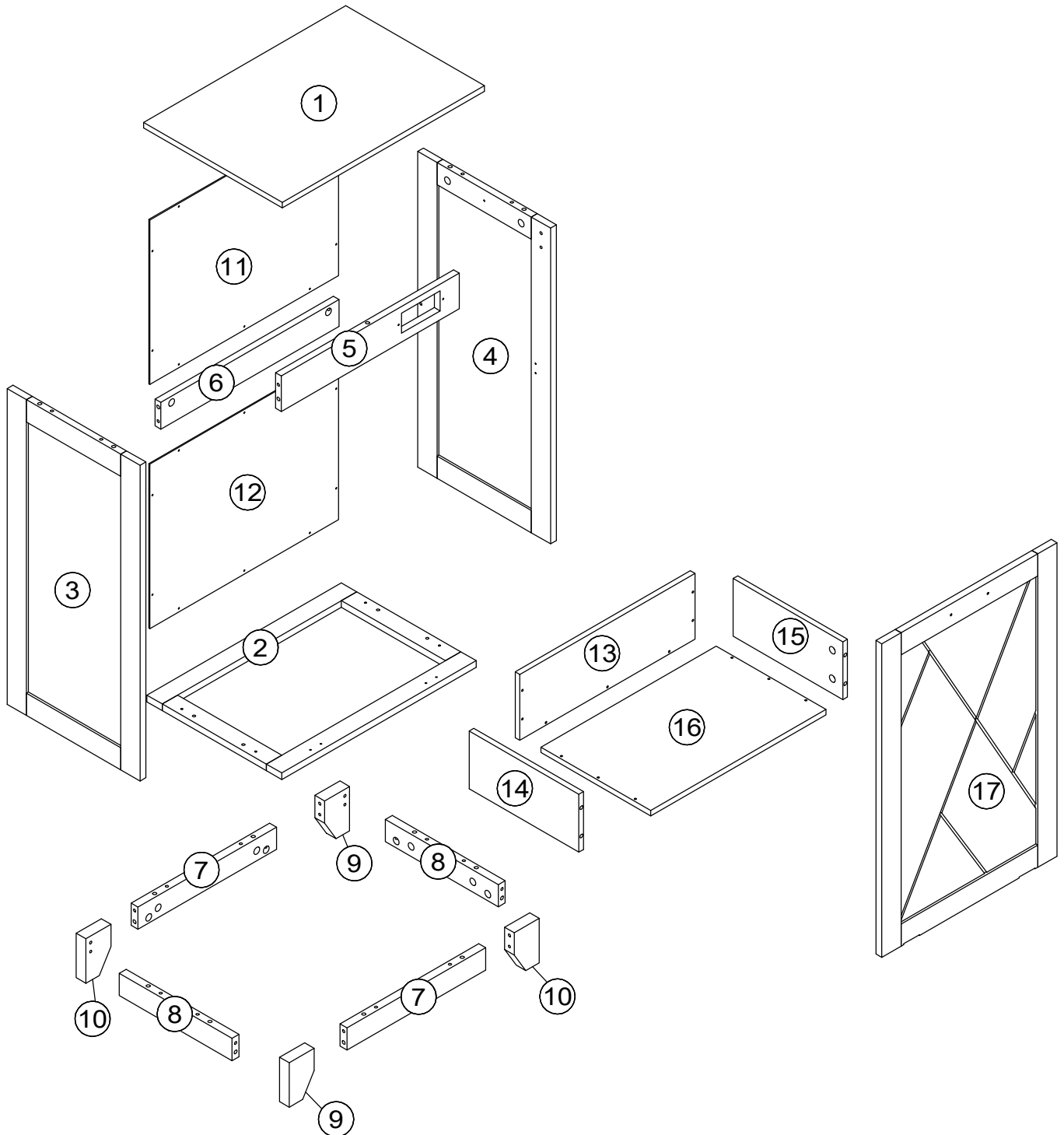

STEP1

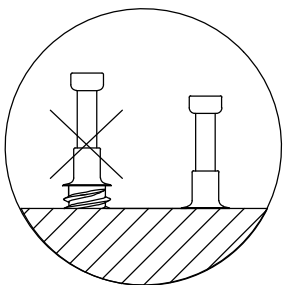
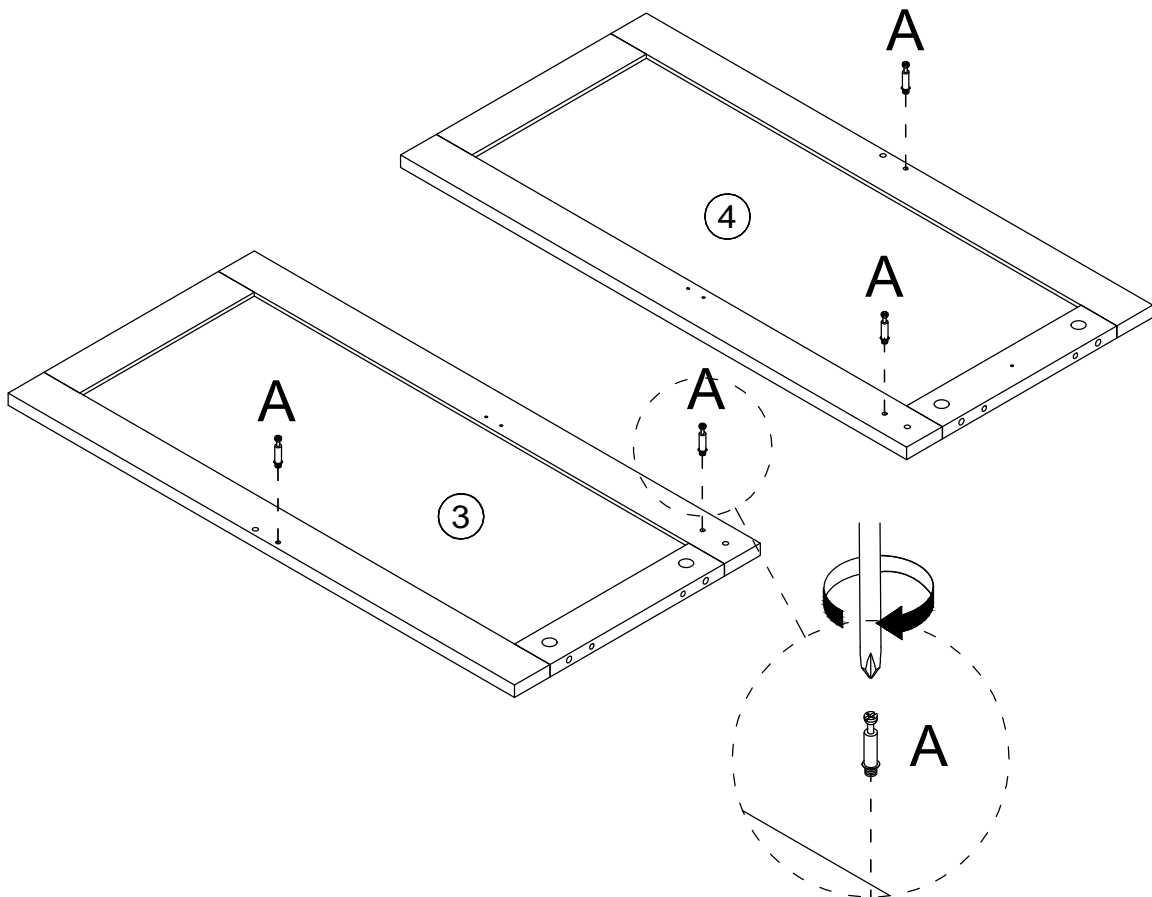
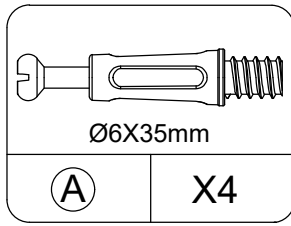
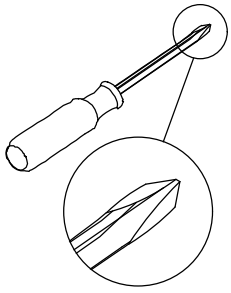

STEP 2

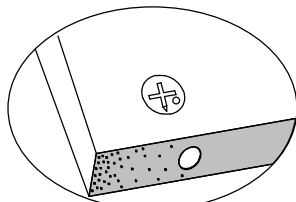
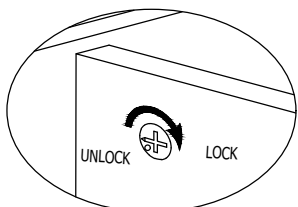
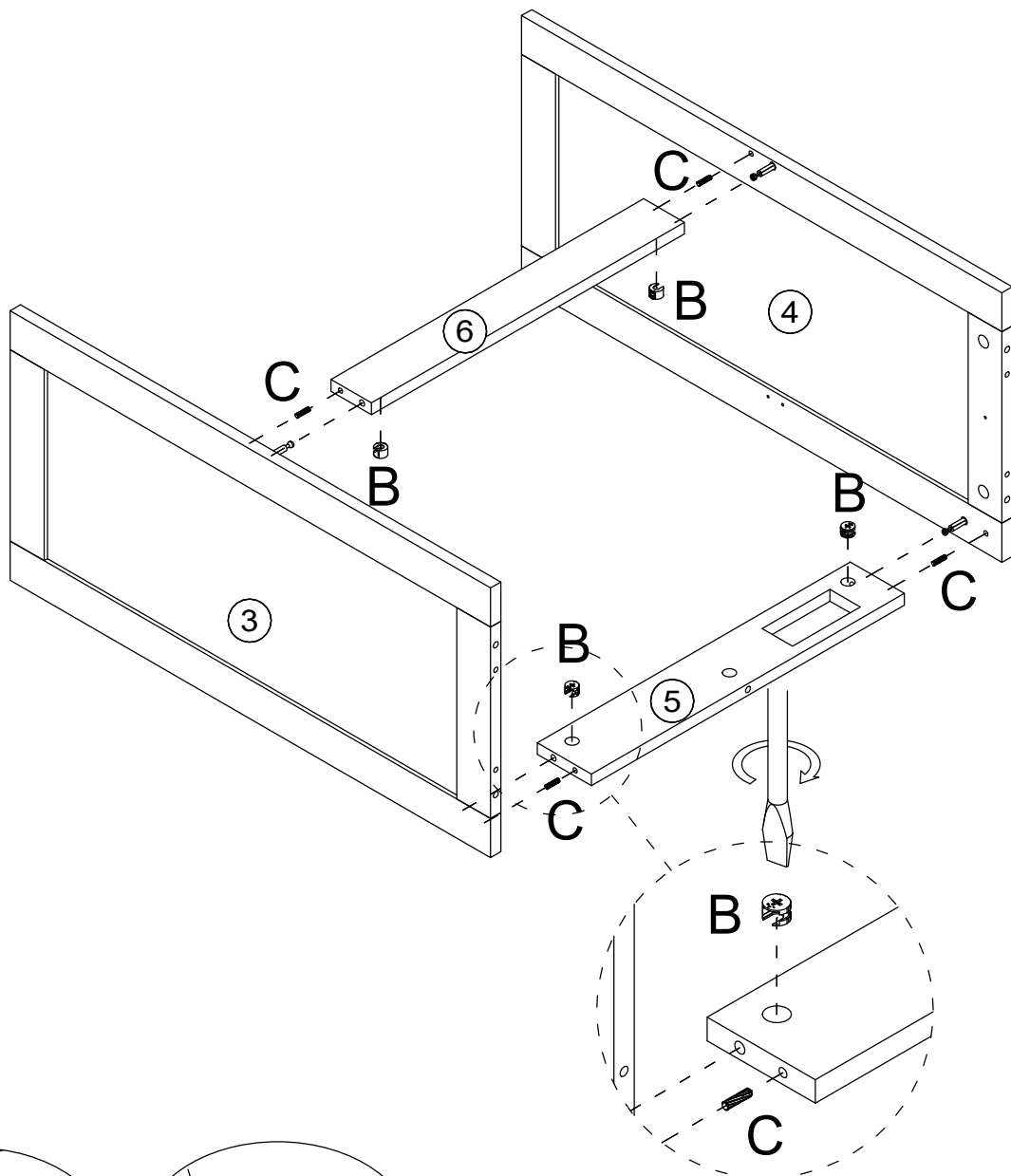
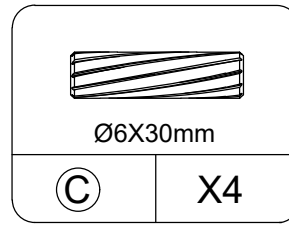
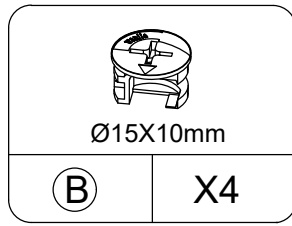
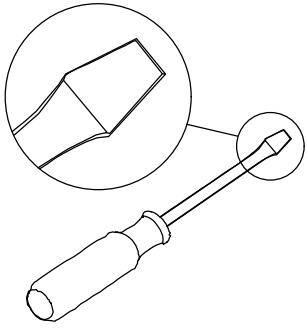

Proper orientation of CAM LOCK

STEP 3

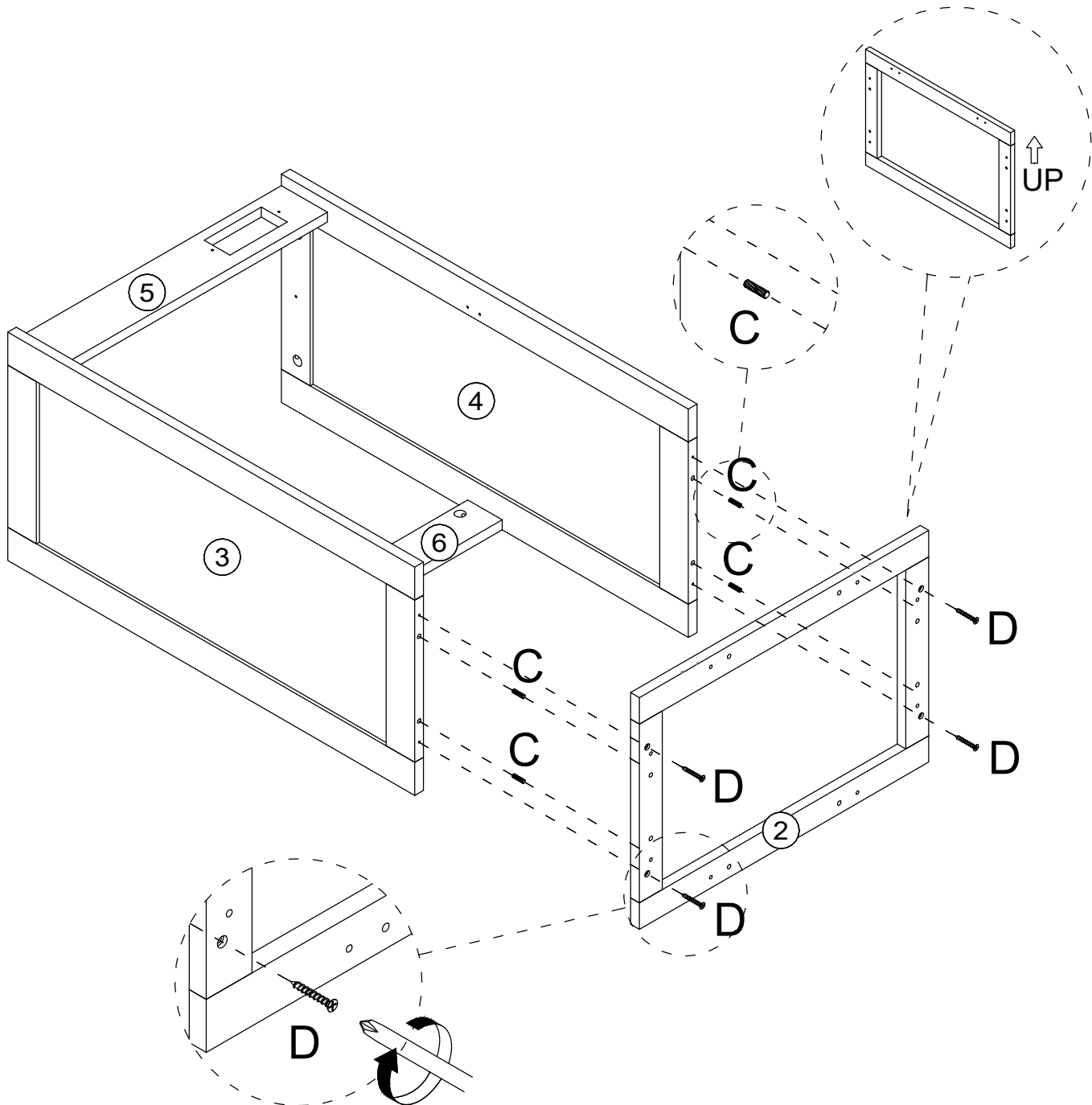
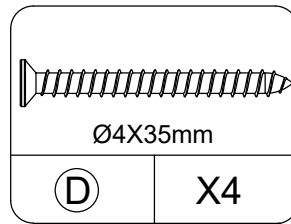
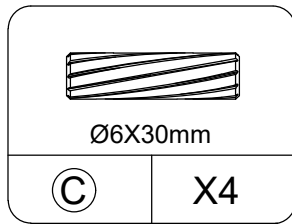
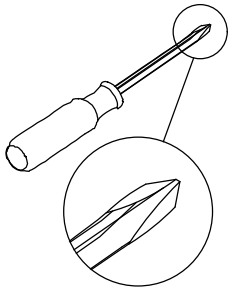

STEP 4

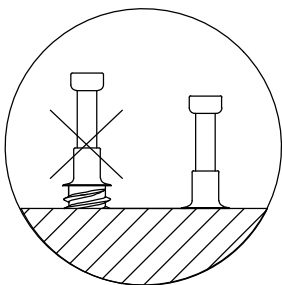
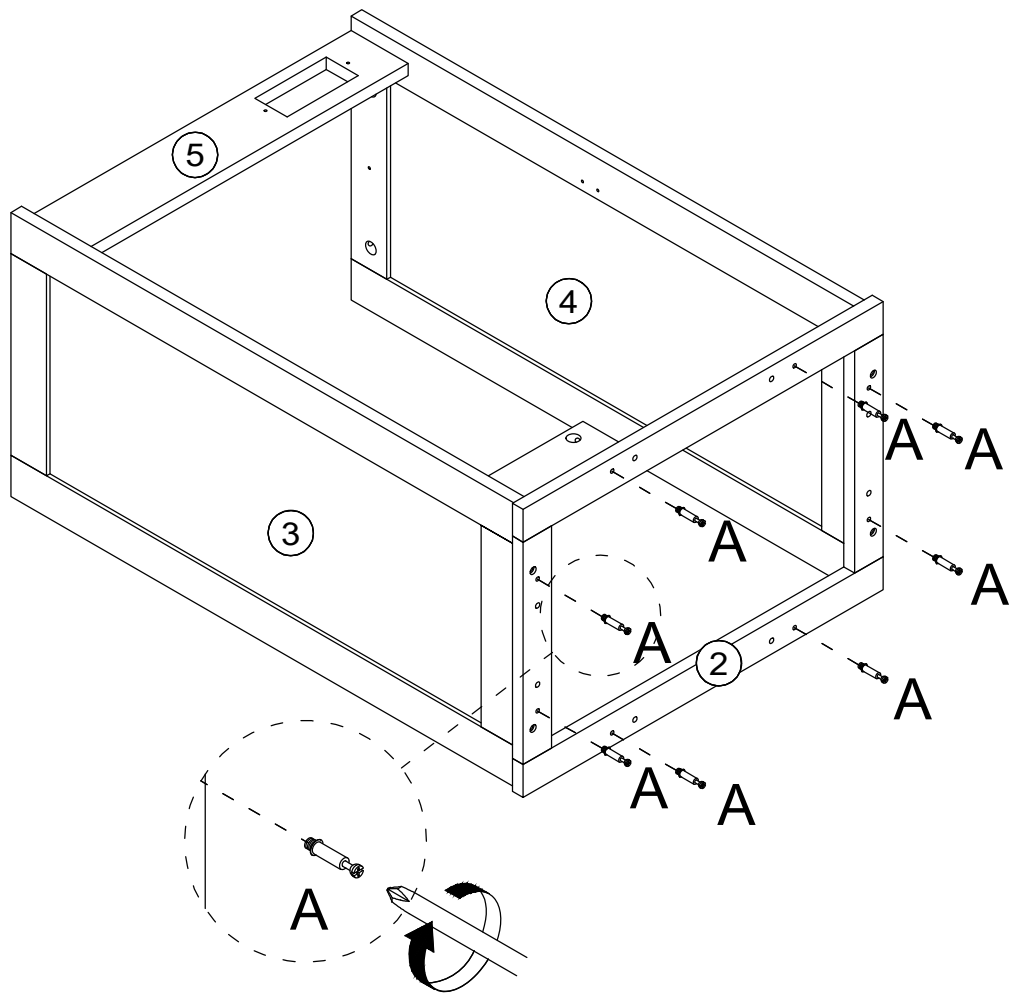
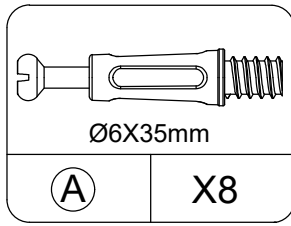
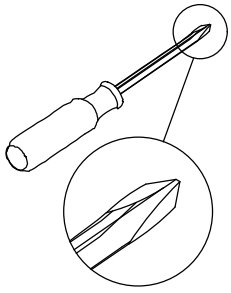

STEP5

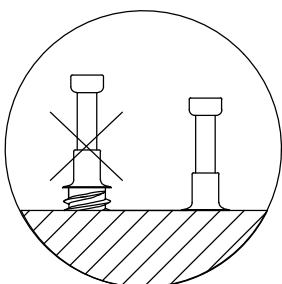
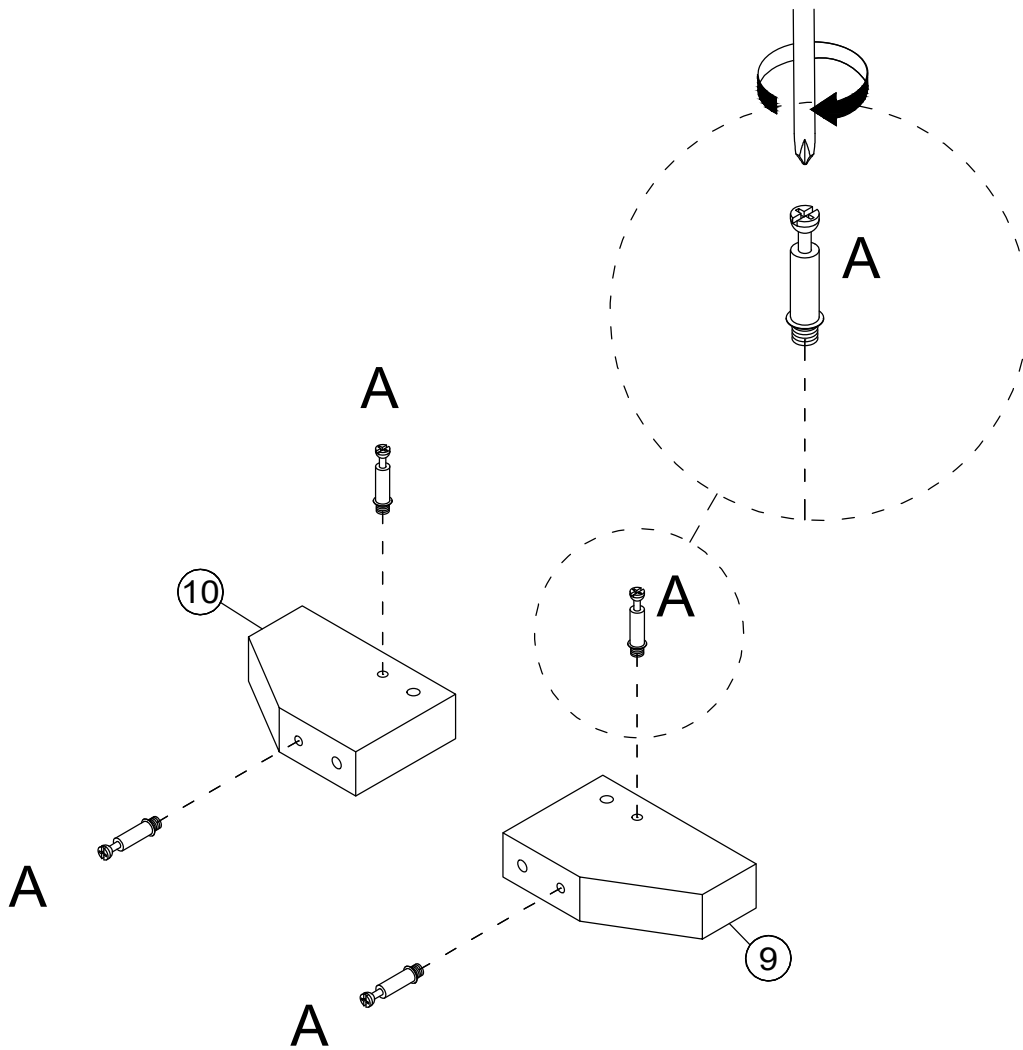
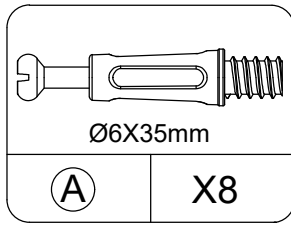
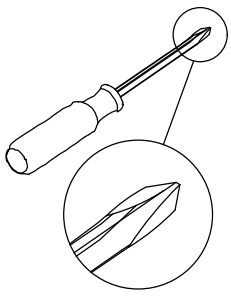

X2

STEP 6

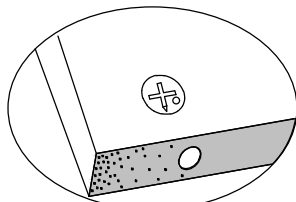
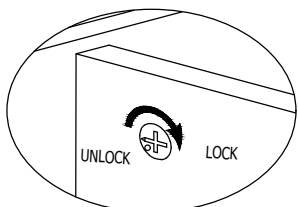
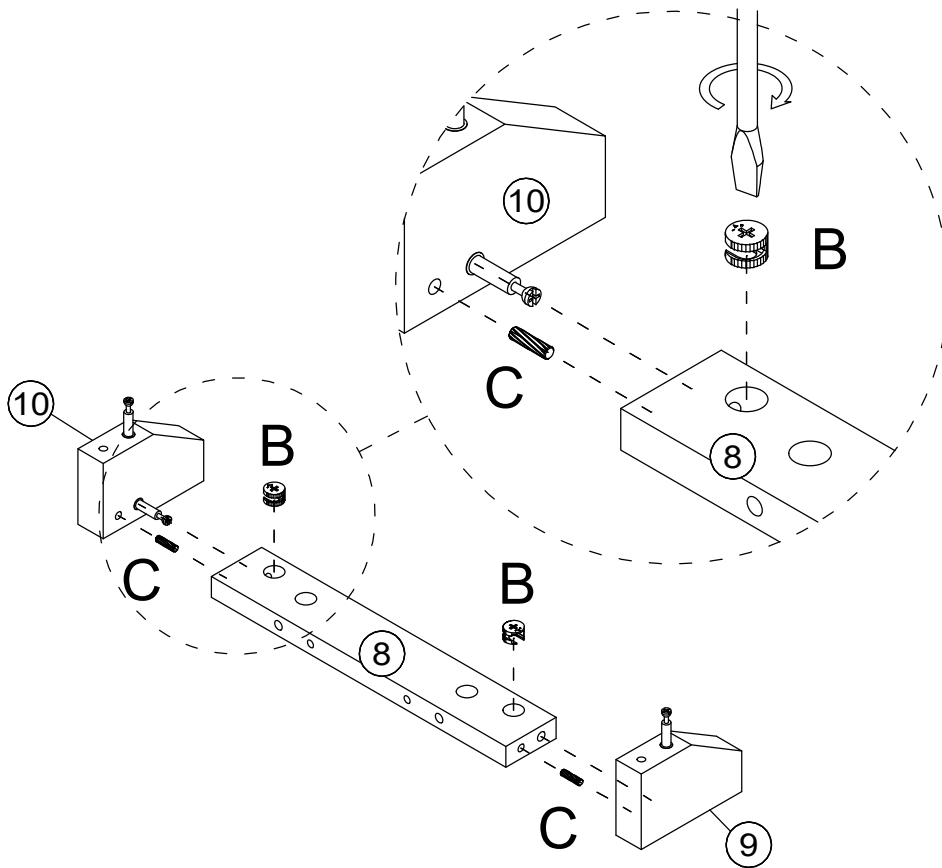
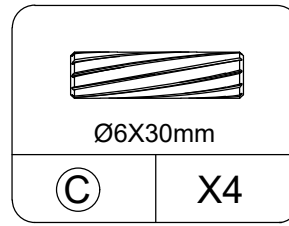
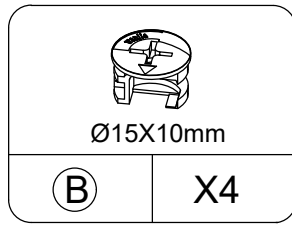
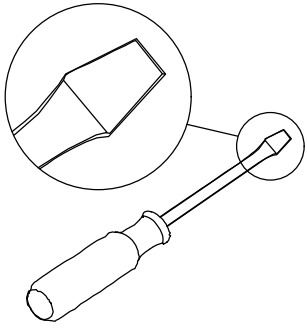

Proper orientation of CAM LOCK

X2

STEP 7

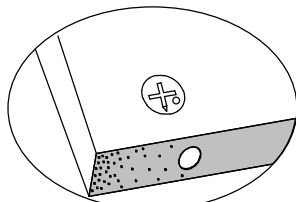
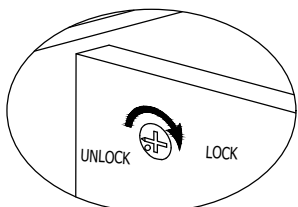
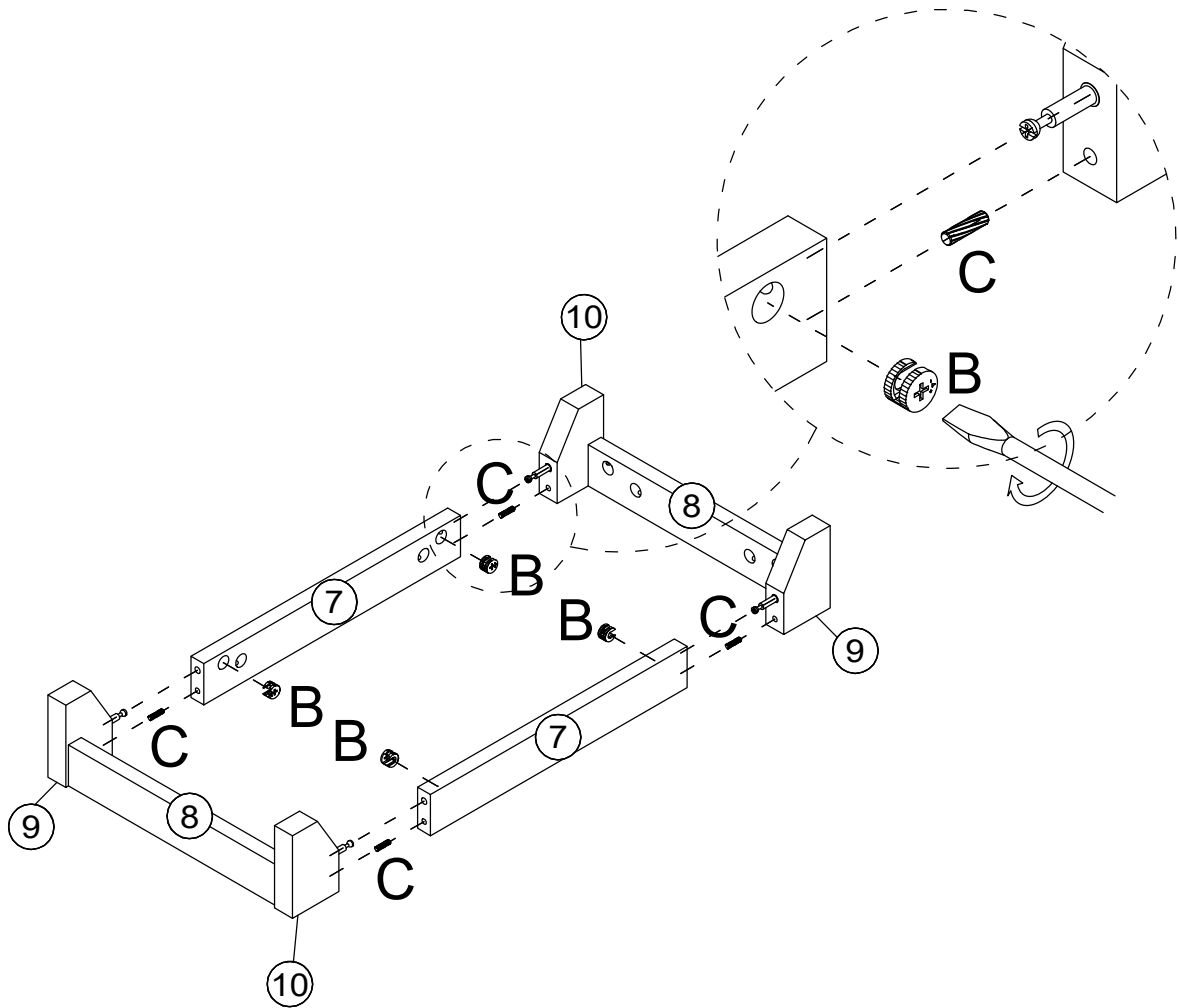
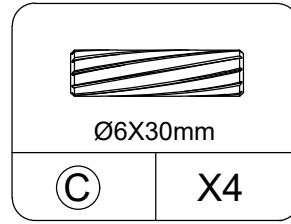
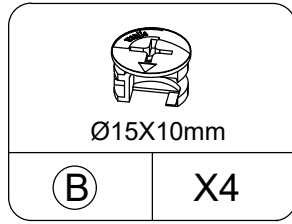
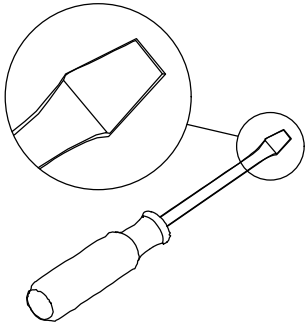

Proper orientation of CAM LOCK

STEP 8

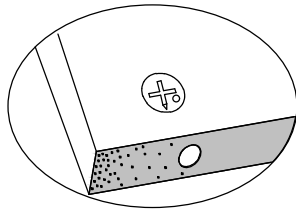
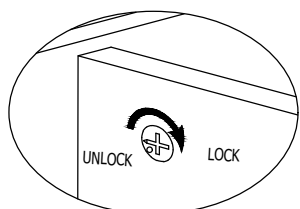
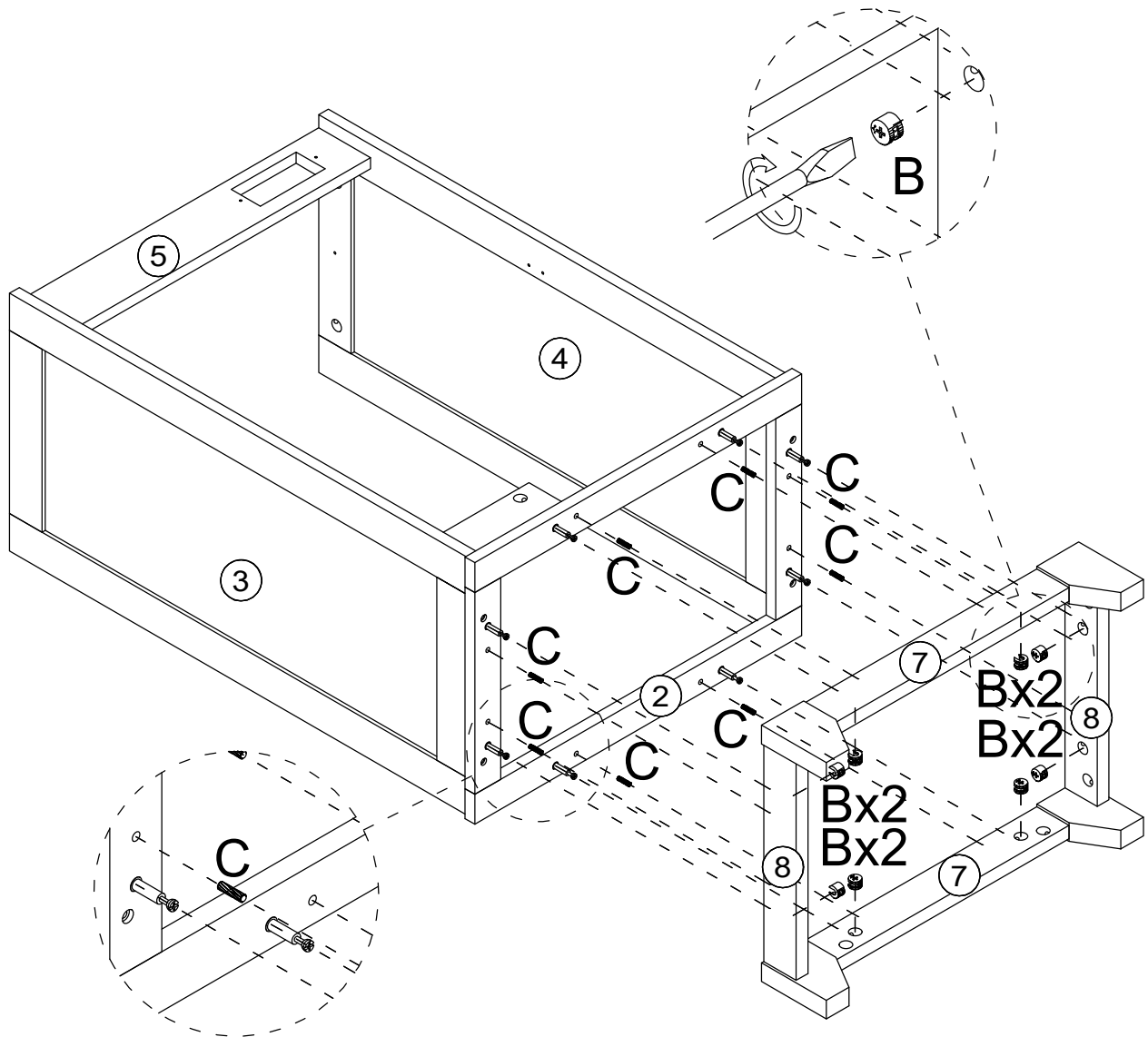
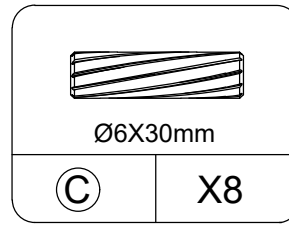
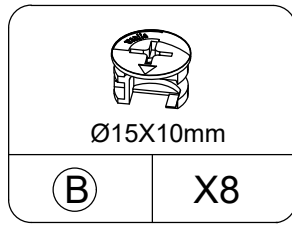
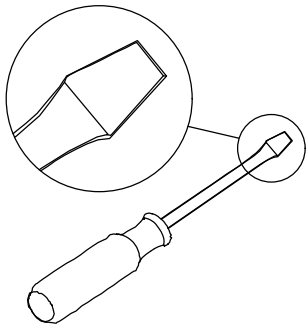

Proper orientation of CAM LOCK

STEP9

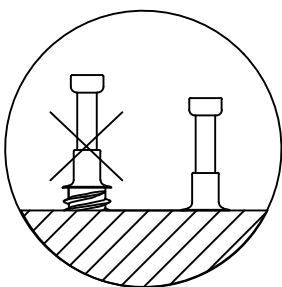
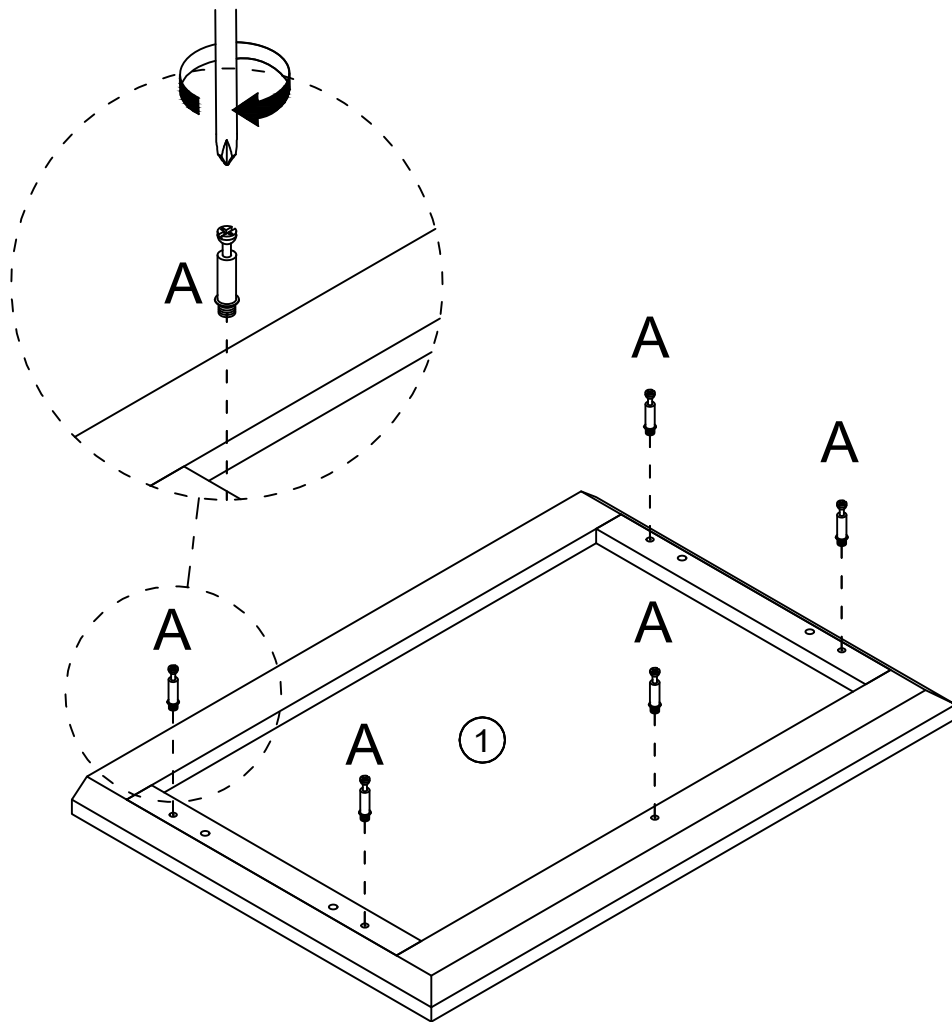
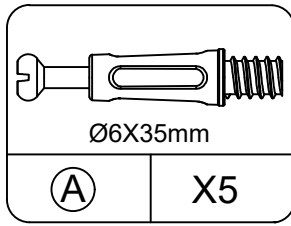
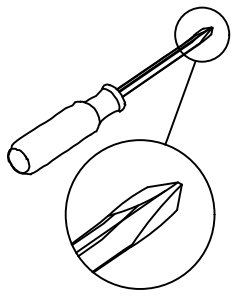

STEP10

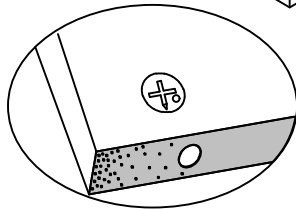
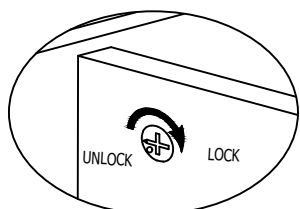
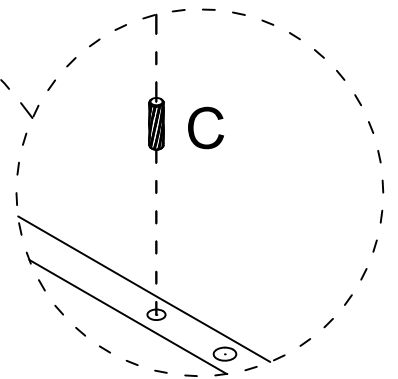
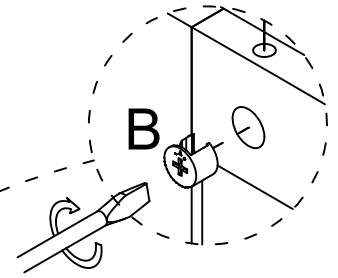
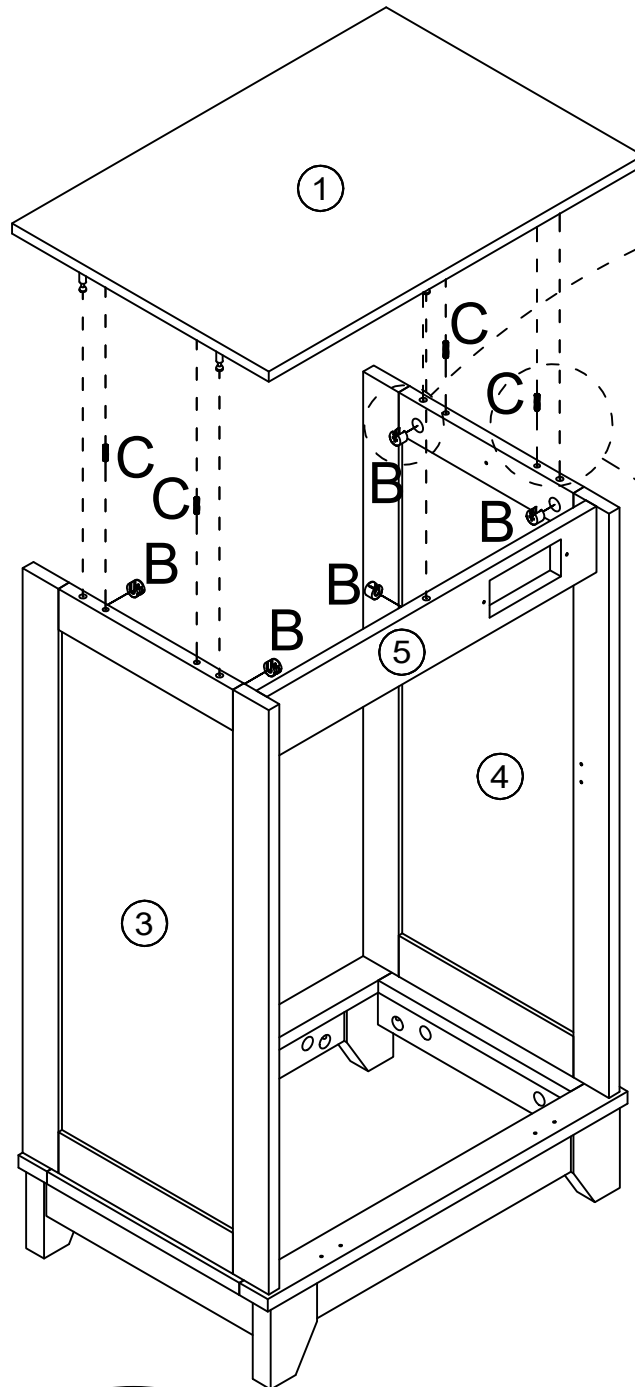
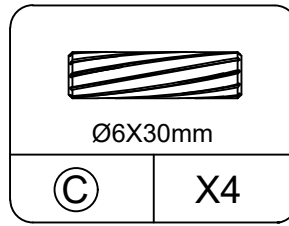
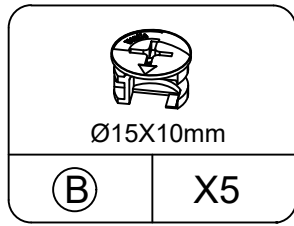
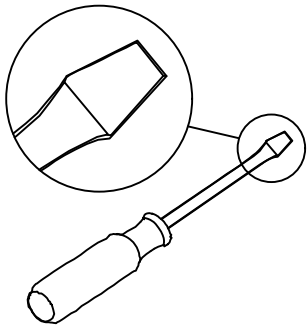

Proper orientation of CAM LOCK

STEP11

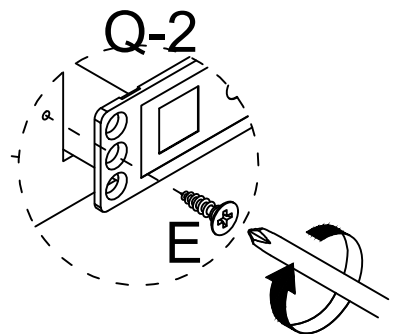
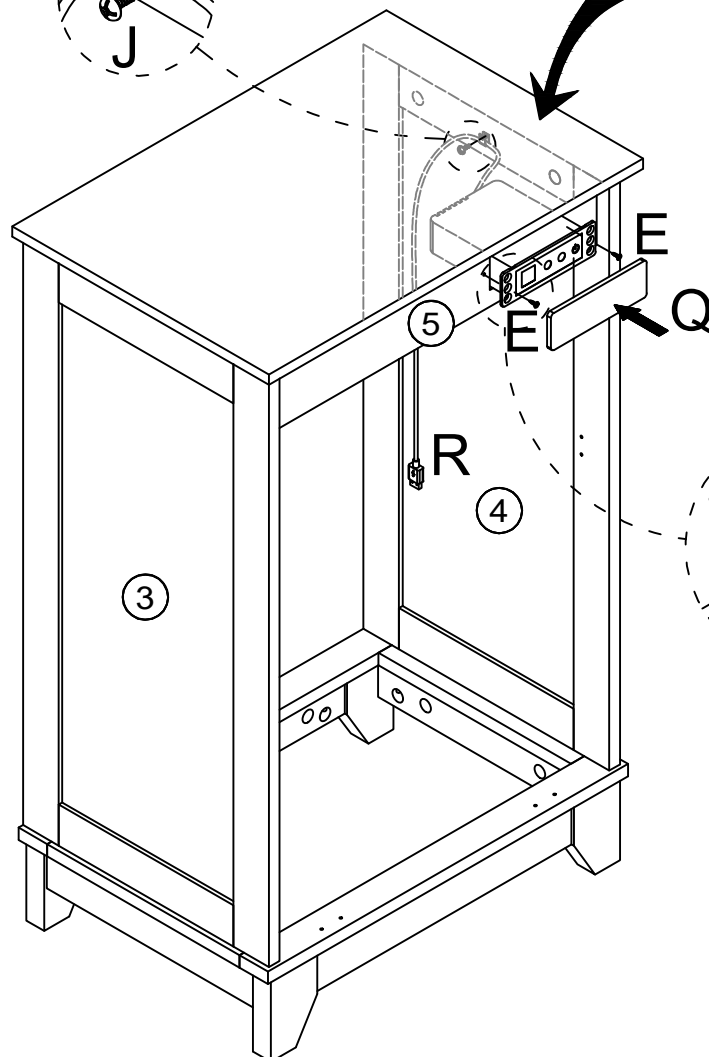
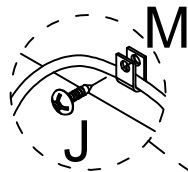
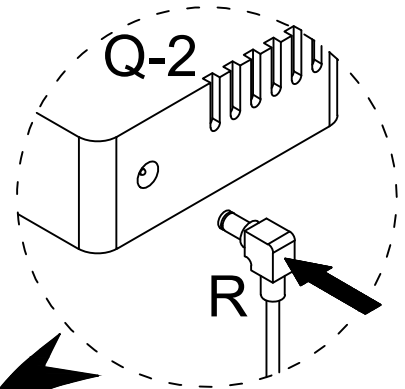
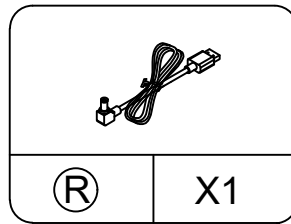
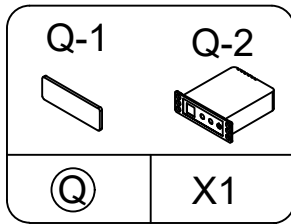
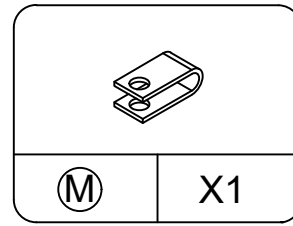
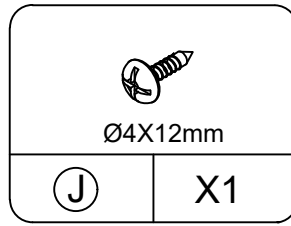
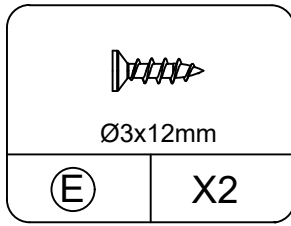
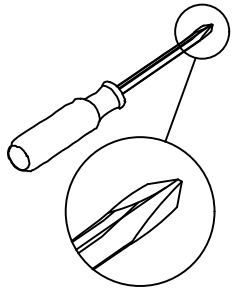

STEP 12

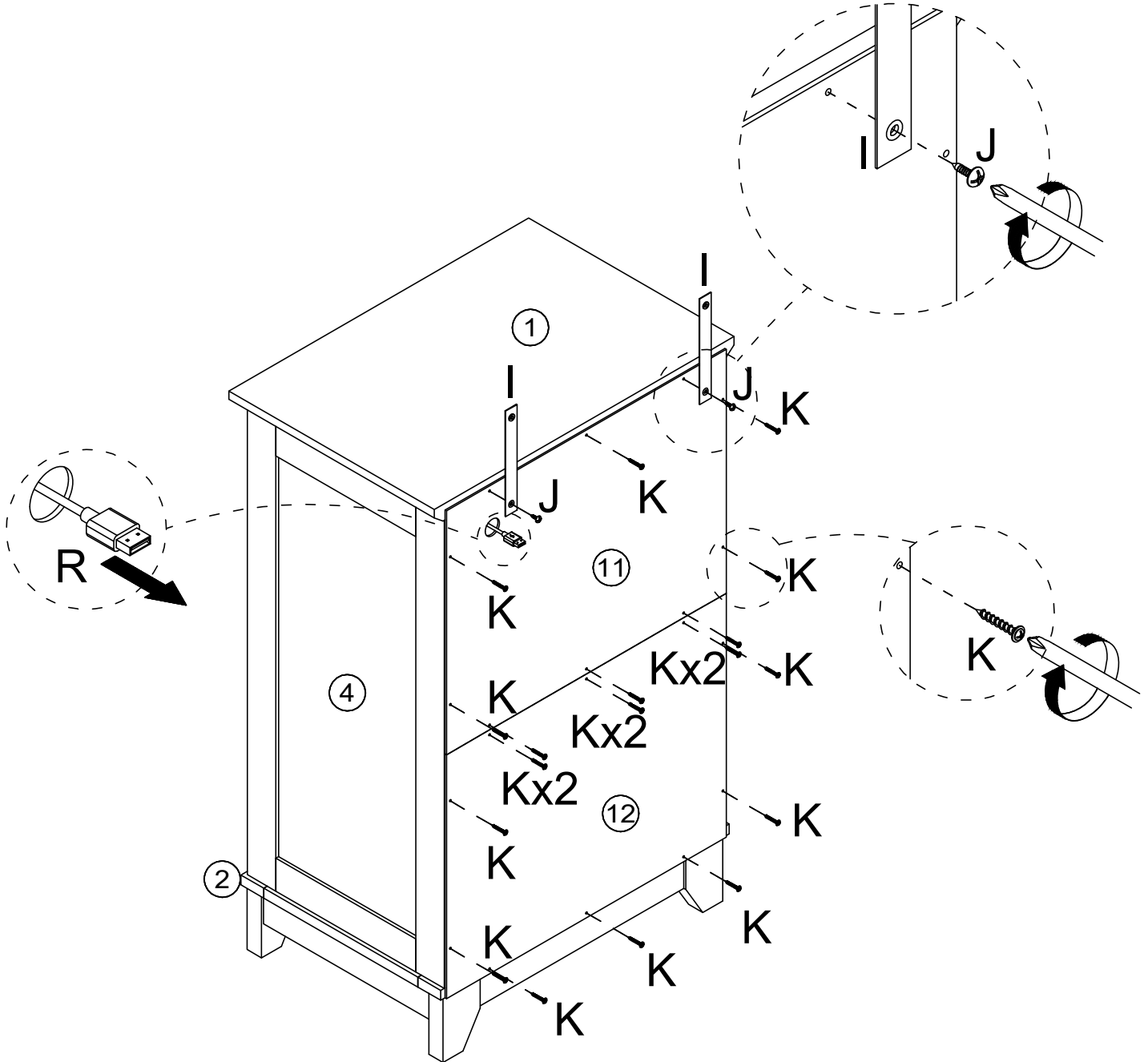
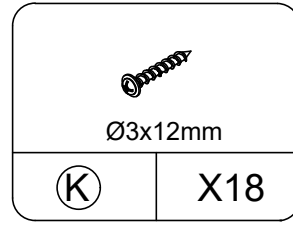
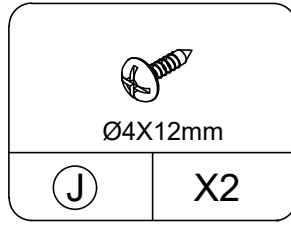
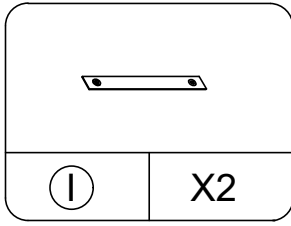
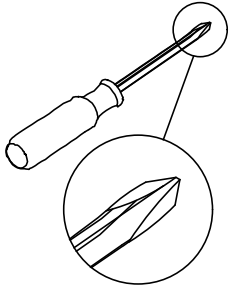

STEP 13

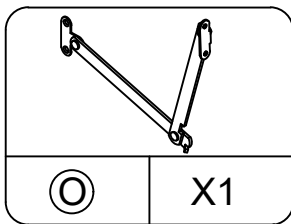
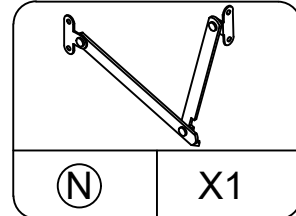
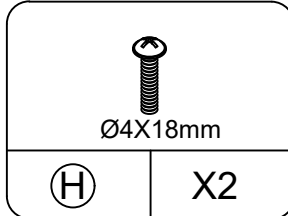
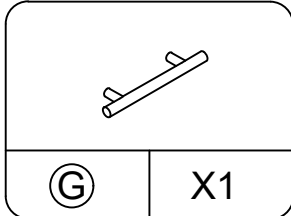
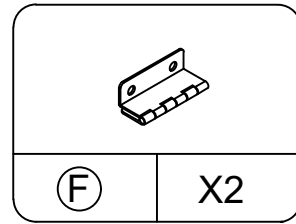
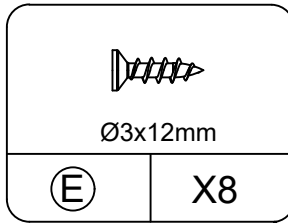
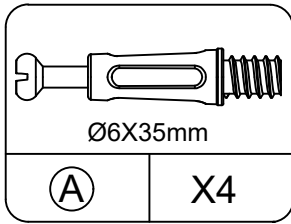
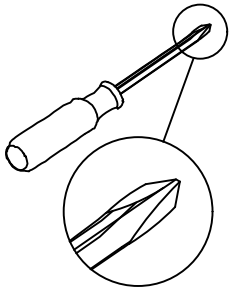

Notice the opening facing down

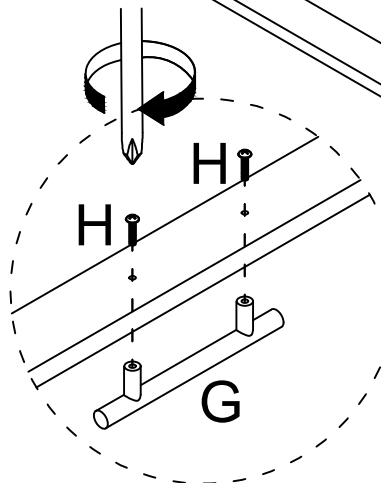
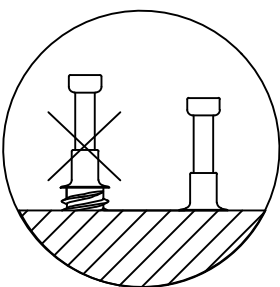
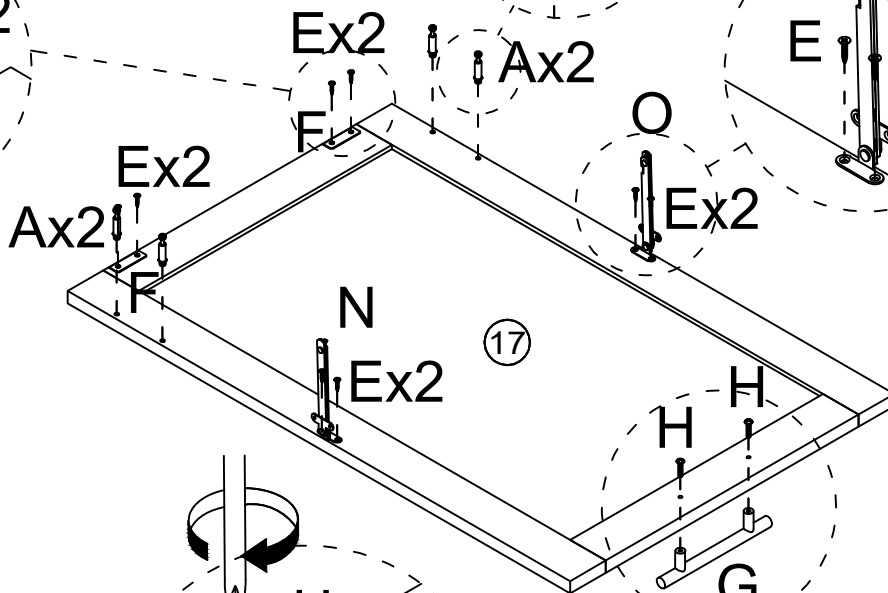
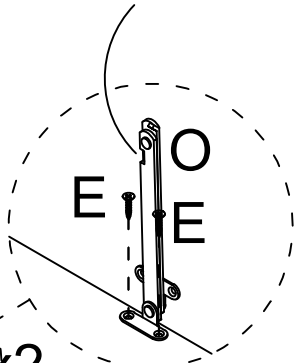
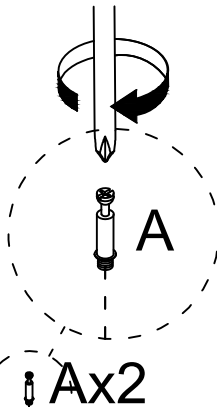
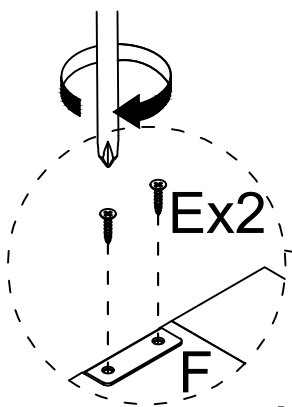

STEP14

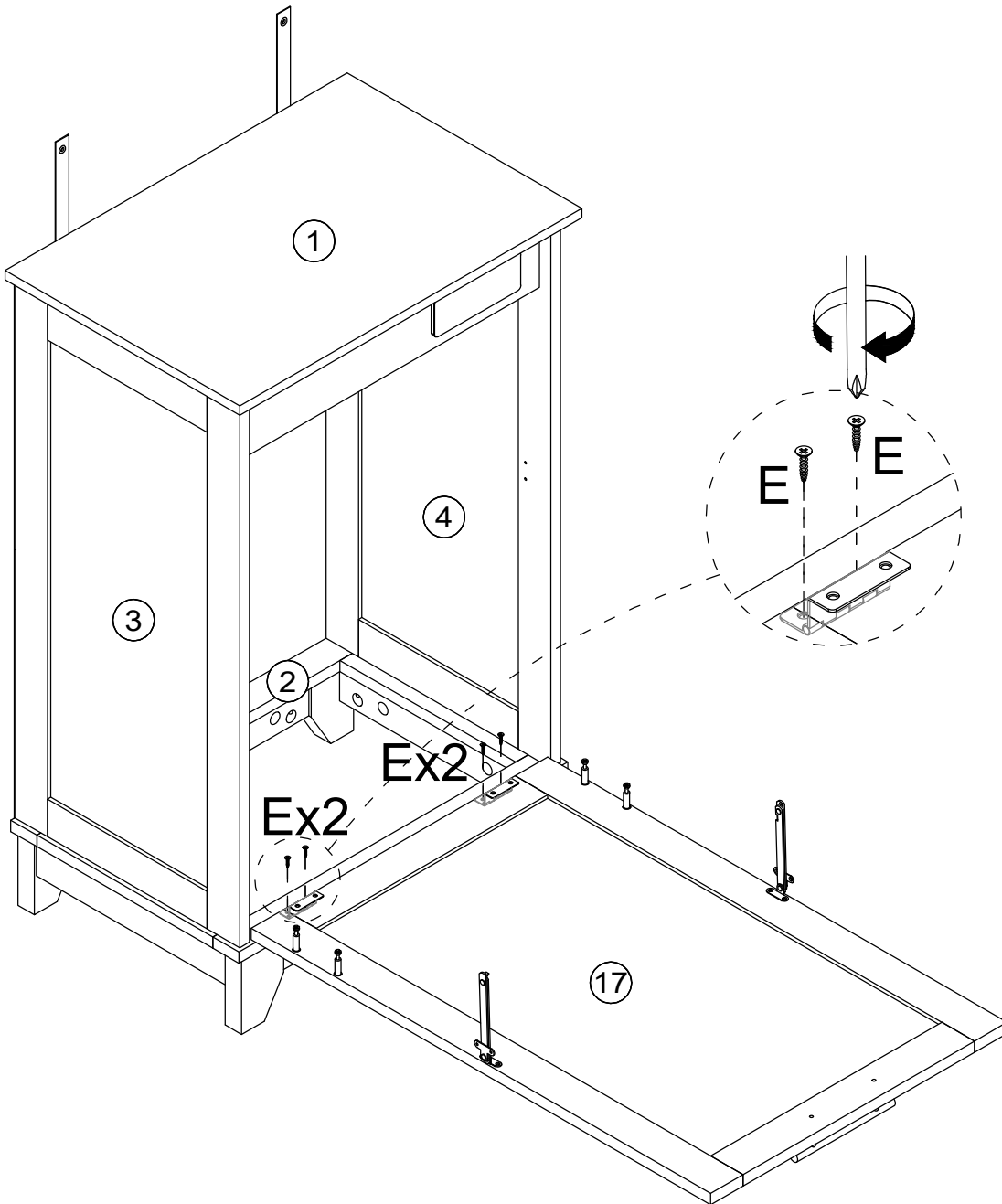
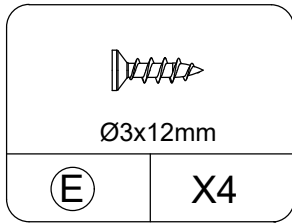
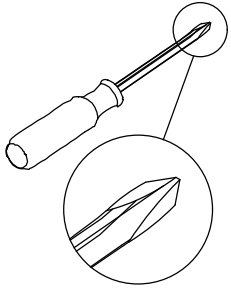

STEP15

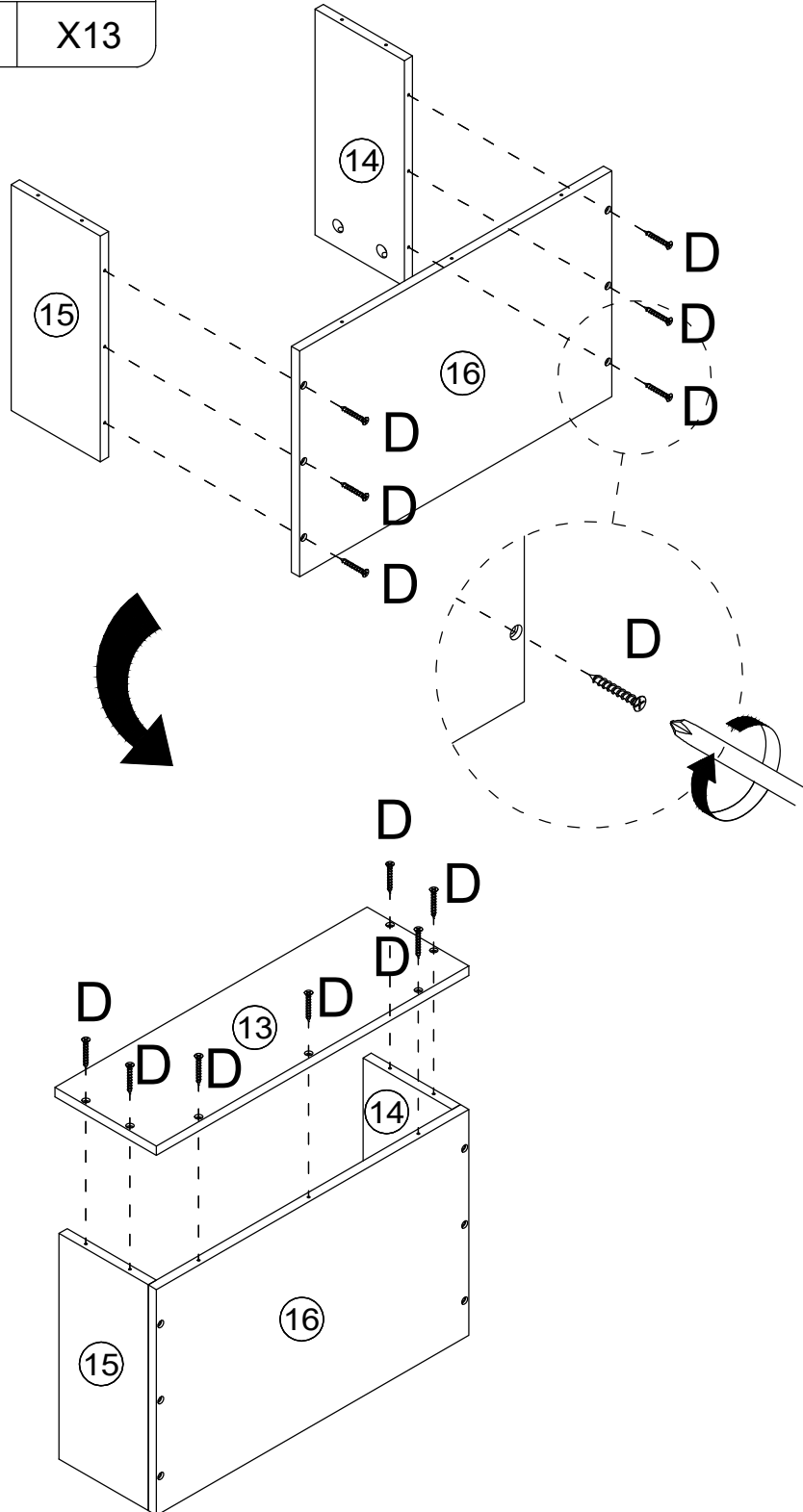
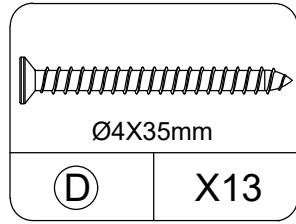
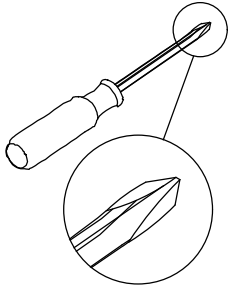

STEP 16

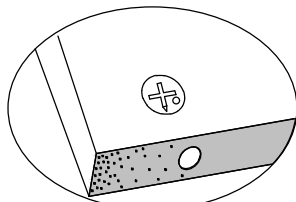
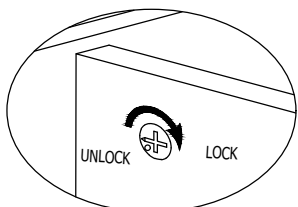
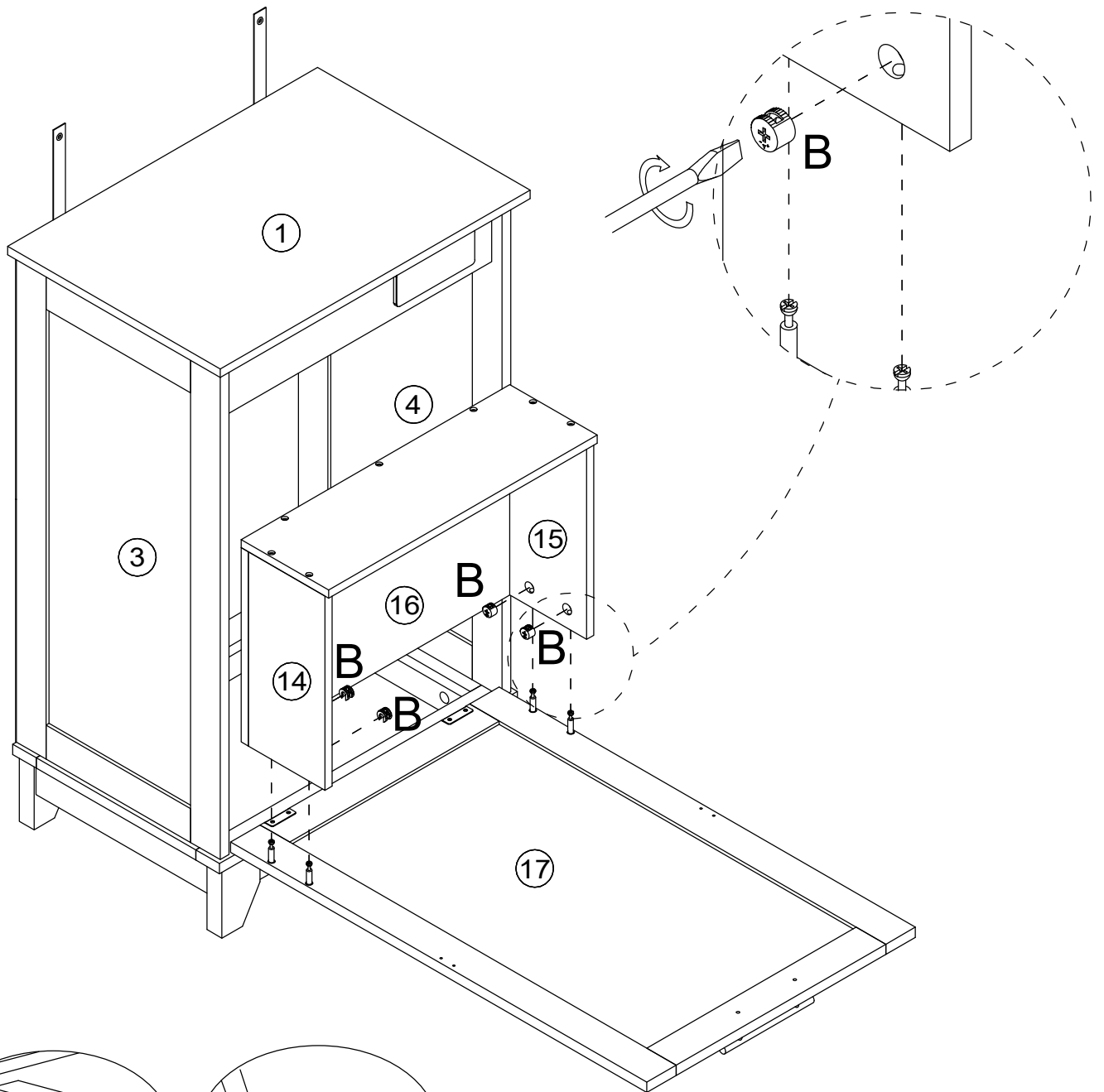
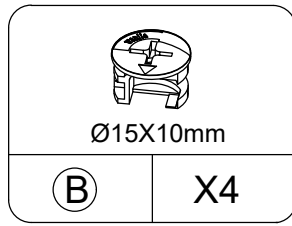
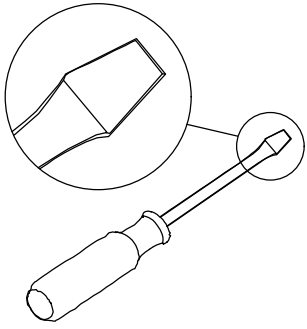

Proper orientation of CAM LOCK

STEP17

