

# CANTRIO KONCEPTS



## KSS-518

### FEATURES:

- \* Sink Size: 31-1/2" x 20-1/2" x 9"/7"
- \* Material: 304 Stainless Steel, 18 Gauge
- \* Undercounter Sink
- \* Strainer Drain Provided
- \* Warranty: Limited Lifetime Warranty

### CODES / STANDARDS APPLICABLE

- \* CSA B45
- \* ASME A112.19.2

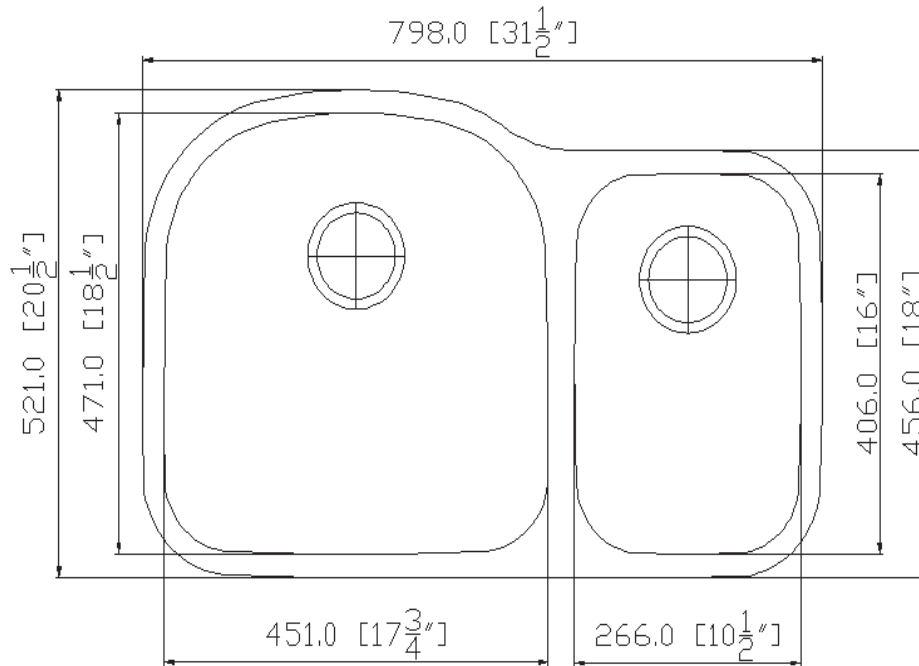

## JOB INFORMATION:

Job Name \_\_\_\_\_

Date Specified \_\_\_\_\_

Contractor \_\_\_\_\_

\* Specifications and drawings provided on this sheet are for illustration only. Cantrio Koncepts will not be held responsible for cutouts made without the actual product or product template.