

ASSEMBLY INSTRUCTION

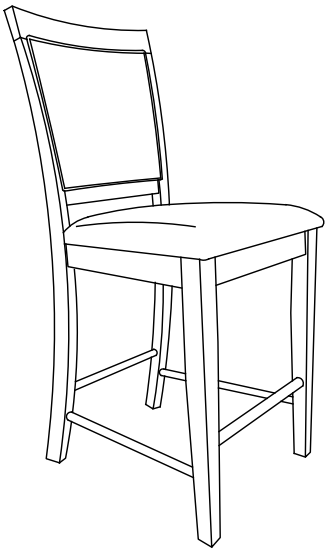

Thank you for purchasing the product. Please take time to read and follow the instructions below. Check that you have all parts and hardware before assembly. Parts apparently missing are often found in the packing materials. If you do not have all the parts listed, have your dealer contact us and they will be sent to you immediately.



It is recommended to install protective pads under all legs and supports to avoid damage or scratches when placing furniture on a wood floor or other hard surface, and to limit indentation and prevent discoloration if placing on carpet.

PARTS LIST			
No	Sketch	Description	Quantity
1		Chair Back	1PC
2		Cushion Seat With Frame	1PC
3A 3B		LSF Leg RSF Leg	1PC 1PC
4		Front Cross Bar	1PC
5		Cross Bar	2PCS

HARDWARE LIST				
No	Description	Size	Sketch	Quantity
A	JCBC Bolt	M6X70mm		8PCS
B	JCBC Bolt	M6X40mm		2PCS
C	Spring Washer	M6X13mm		10PCS
D	Flat Washer	M6X18mm		10PCS
E	Wood Screw	M5X32mm		6PCS
F	Allen Key	M4		1PC

**Above hardware are packed in 5825-24 for assembly.

STEP 1

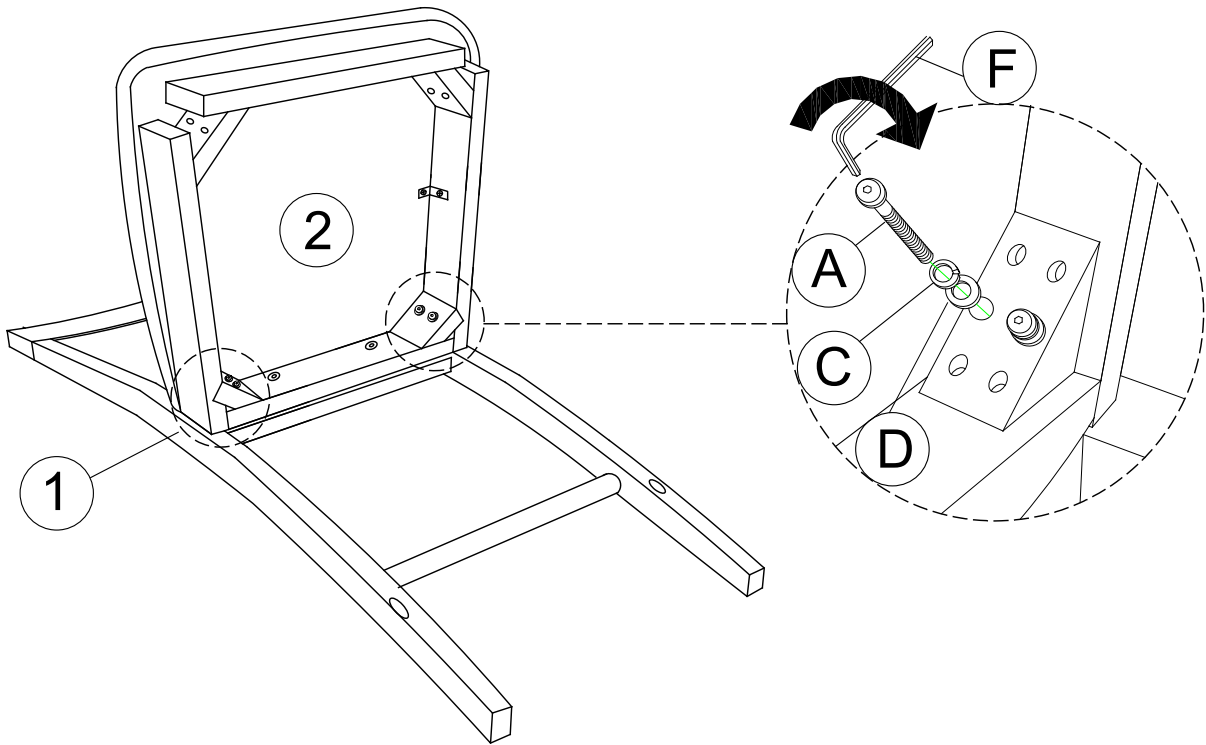

STEP 2

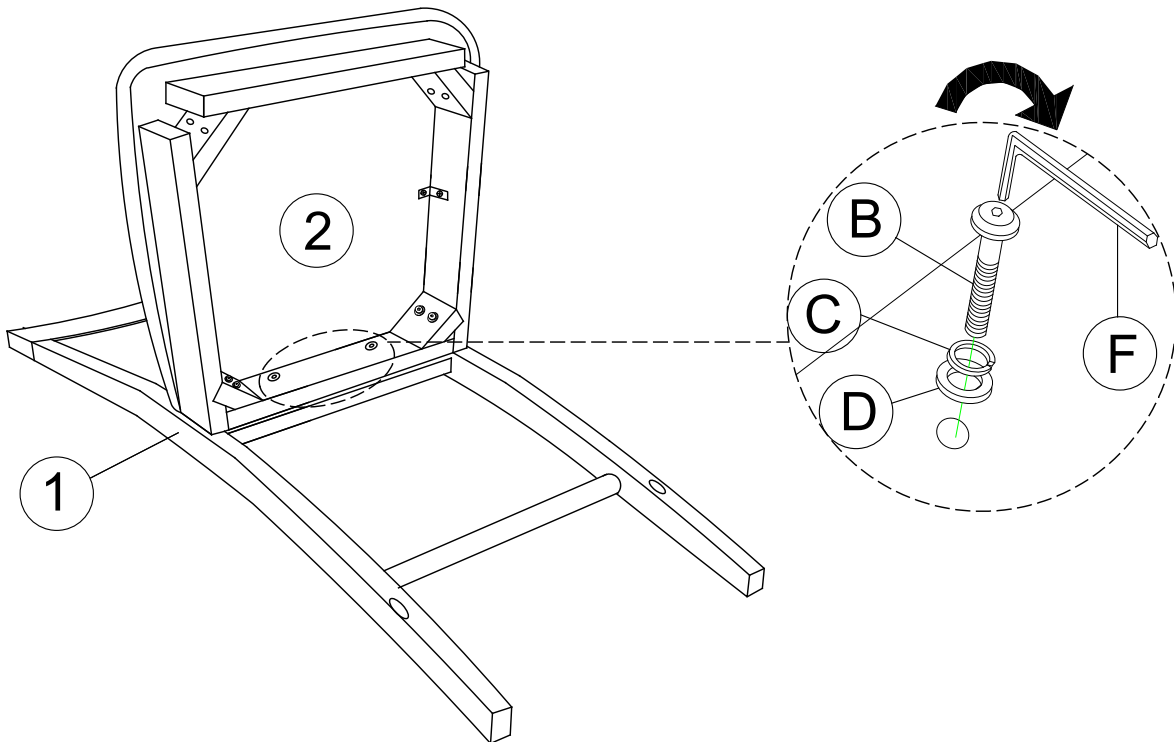

STEP 3

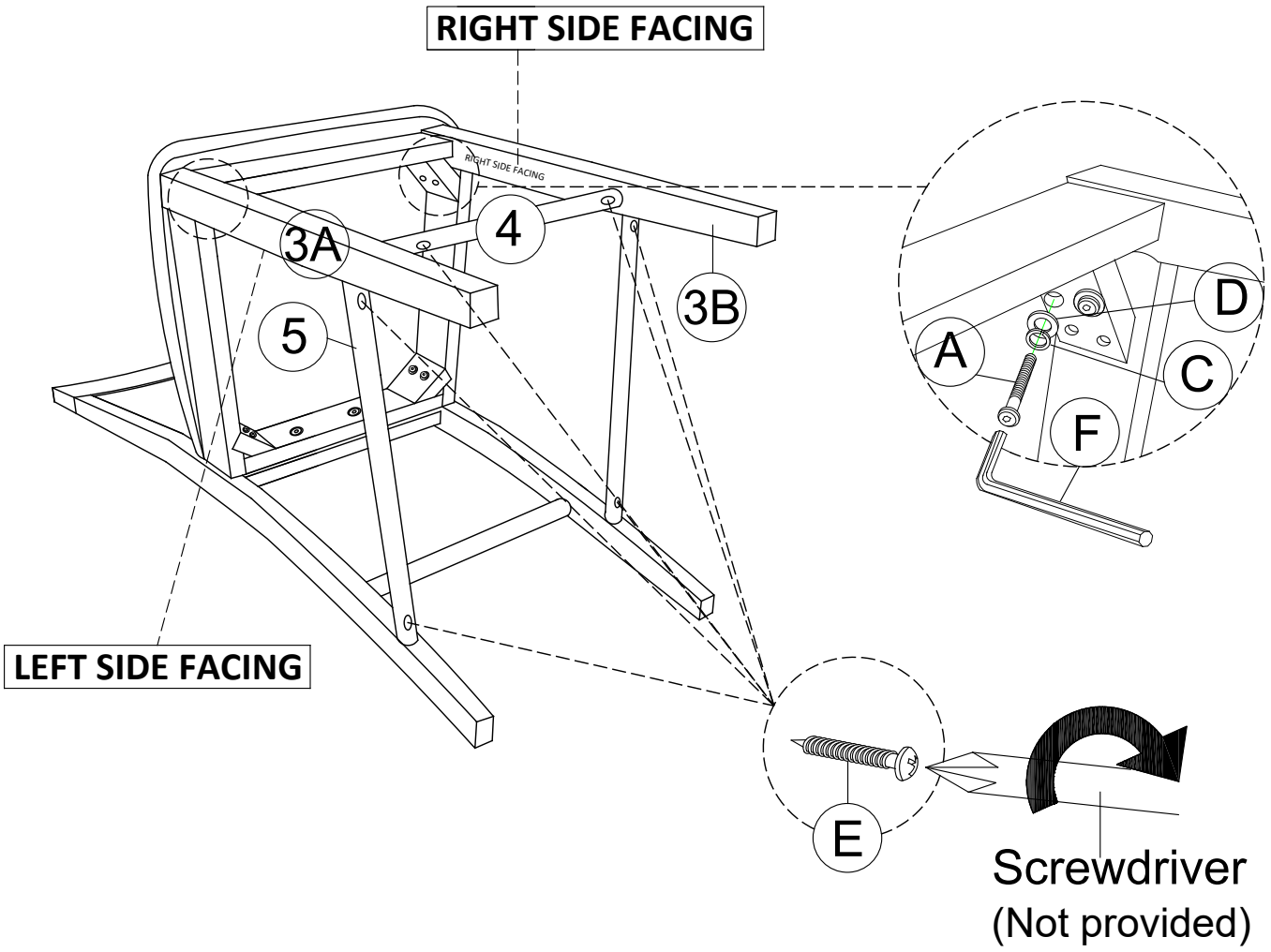

STEP 4 COMPLETED

