

CHAIR & TABLE COMPANY

ASSEMBLY INSTRUCTION

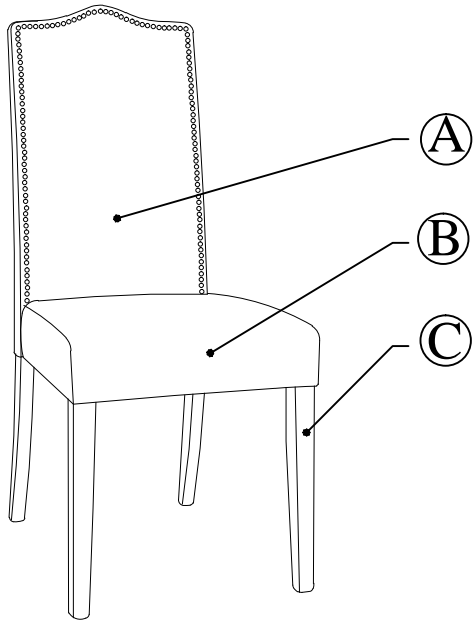

PARTS CHECK LIST

CODE	COMPONENTS	Q'TY
(A)	BACK REST	x01
(B)	SEAT	x01
(C)	FRONT LEG	x02

FITTINGS CHECK LIST

CODE	DESCRIPTION	Q'TY
(D)	JCBC M6 x 70mm (RB)	x04
(E)	JCBC M6 x 60mm (RB)	x04
(F)	JCBC M6 x 45mm (RB)	x02
(G)	SPRING WASHER Ø1/4 (RB)	x10
(H)	FLAT WASHER Ø1/4 x 19mm (RB)	x10
(I)	ALLEN KEY M4 x 60mm	x01

1. Assemble FRONT LEGS to the SEAT as illustrated below. DO NOT TIGHTEN THE SCREWS UNTIL FULLY SET UP.

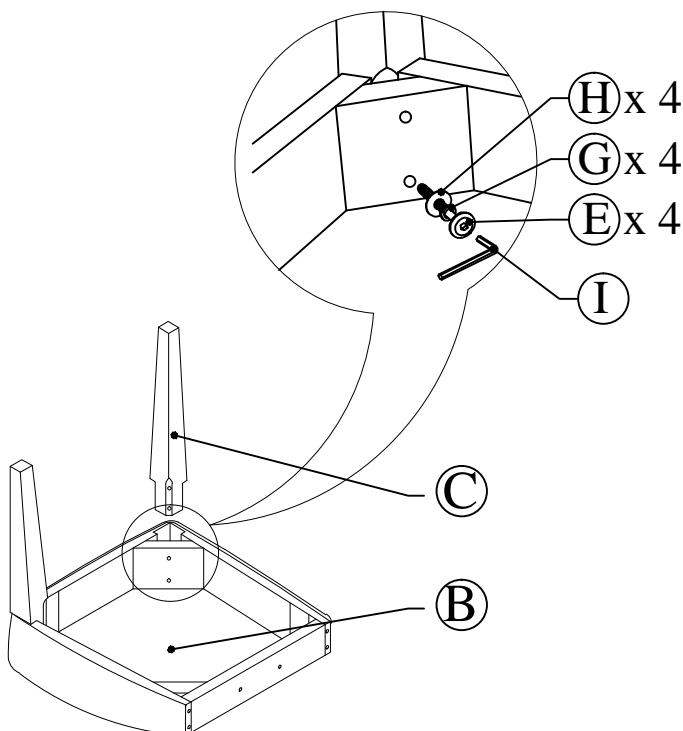

2. Assemble BACKREST to the SEAT as illustrated below. TIGHTEN ALL THE SCREWS !!!

