

ASSEMBLY INSTRUCTIONS & PARTS IDENTIFICATION







DINING CHAIR

Thank you for purchasing this quality product. Be sure to check all packing material carefully for small parts that may have come loose inside the carton during shipment

Key Parts

No	Code	Qty	Description
1	NOT AVAILABLE AS A PART	1 pc	Chair Back
2	2511-400KDP41	1 pc	Complete seat
3	2511-400KDP42	2 pcs	Front Legs
4	2511P01F	4 pcs	Floor glide

Hardware kit

No	Description	Q'Ty
A	 Hexa Nut Ø5/16"	4 pcs
B	 Lock Washer 5/16"	11 pcs
C	 Flat Washer 5/16"	11 pcs
D	 Long Bolt 1/4" x 3"	4 pcs
E	 Short Bolt 1/4" x 1-5/8"	3 pcs
F	 Allen Wrench	1 pc
G	 Key Wrench	1 pc

FABRIC CARE INSTRUCTIONS

REGULAR CARE

FABRIC CONTENT

100% POLYESTER - CLEANING CODE WS

Water-based cleaning agents, foam or mild water-free cleaning solvents may be used. Never use tap water. Use distilled water, as tap water contains minerals that may cause rings or fading. Do not saturate fabric.

DO NOT USE POWER TOOLS TO ASSEMBLE

STEP 1

- Carefully lay Chair Back flat on a smooth flat surface to prevent scratches.
- Attach Complete Seat to Chair Back by inserting a Flat Washer, Lock Washer and Short bolt into each of the hole on the back of the seat. Do not fully tighten at this point.
- Insert a Flat Washer, Lock Washer and Long screw into each of 2 holes in the Complete Seat corners.
- Tighten all bolts with provided Key Wrench.(See Detail B).

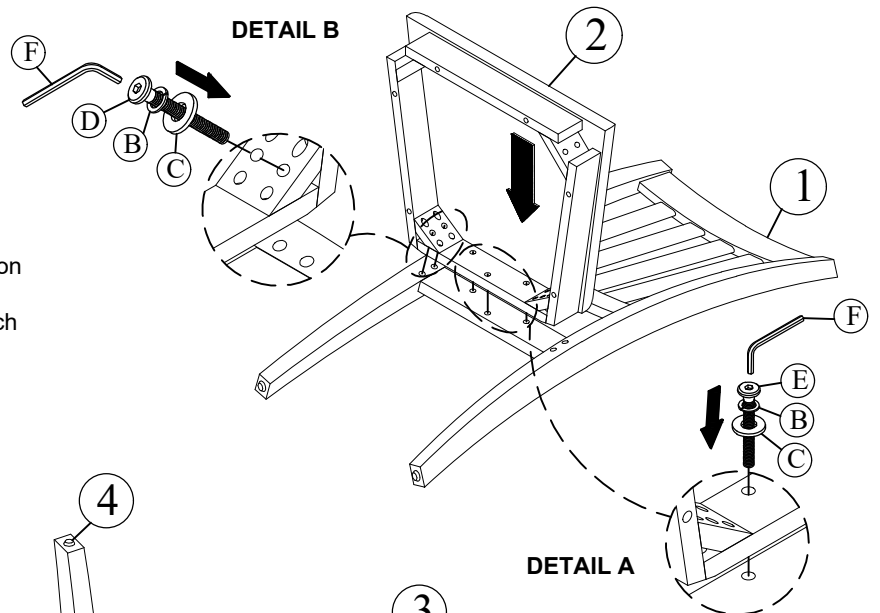

STEP 2

- Carefully turn the chair upside down and attach each Leg to the front corners of the Complete Seat. Place a Flat Washer, Lock Washer and Nut on each leg bolt, tightening the Nut on each Leg using provided Key Wrench. (See Detail C).
- Be sure to level the chair prior to tightening all the nuts and bolts.

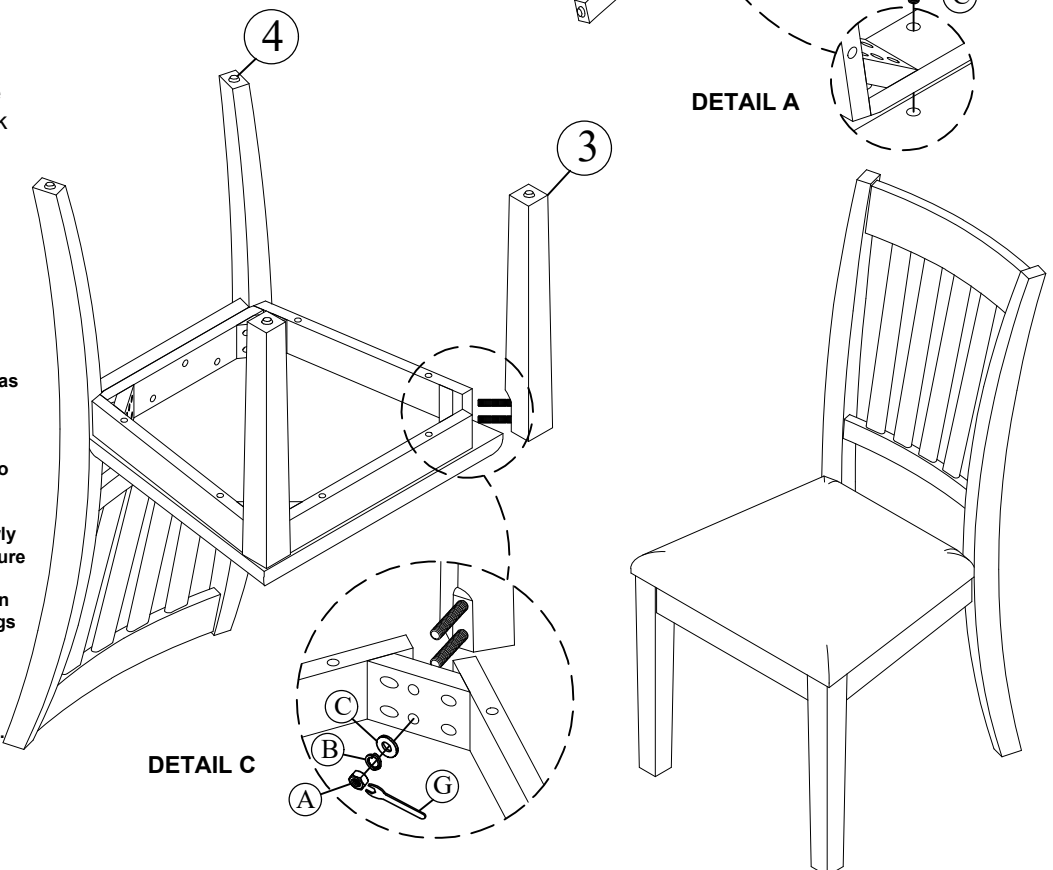

LEVELING A DINING CHAIR.

1. With the chair fully set up, find a level surface such as a kitchen counter top that will accept the chair.
2. Loosen all the back bolts connecting the seat to the back just enough to create movement between the two pieces.
3. With the chair still upright on the level surface, slowly tighten the center bolt until snug, checking to make sure both of the two front legs are still in contact with the level surface. If not loosen the bolt, shift the seat down on the side that the leg did not touch until the both legs rest on the surface. Holding everything steady, tighten the center bolt to secure.
4. Tighten the remaining center bolts fully, always checking that all the legs are in contact to the surface.
5. Fully tighten the corner bolts.