

Installation & Assembly

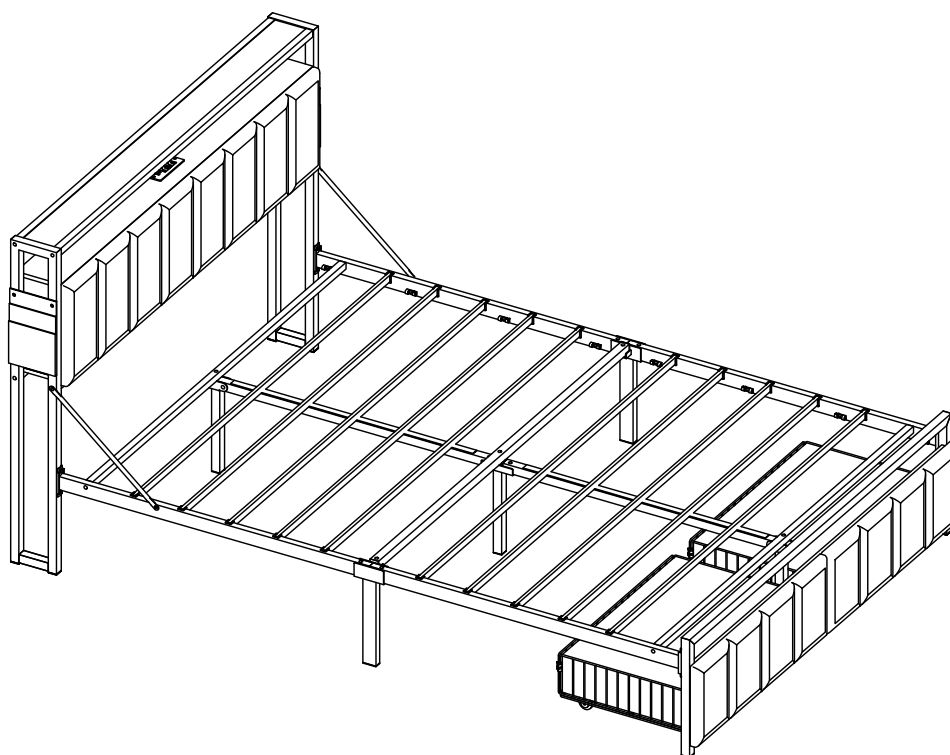

ASSEMBLY INSTRUCTION

Montageanleitung
Instructions De Montage
Istruzioni Per L'assemblaggio
Instrucciones De Montaje
組立説明書
安装说明书



HELPFUL HINTS

BEFORE YOU START

- Inspect product packaging to ensure the appearance is good.
- Read the assembly instruction carefully and follow it step by step.
- To avoid any scratching, putting a soft blanket on the floor is suggested.
- Identify, sort and count all the parts with tags.
- Find out installation position according to the drawing and install it in correct steps.

OTHER

- People needed for assembly: 1-2.
- Estimated assembly time: 1-1.5h.

CAUTION

- Be cautious when using a power drill or power screwdriver.
- Please be aware to slow down and stop when screw is nearly tight.
- Do Not use any harsh chemicals or abrasive cleaners for this item.
- Push, pull or drag this item carefully.

ASTUCES UTILES

AVANT DE COMMENCER

- Inspectez l'emballage du produit pour vous assurer que l'apparence est bonne.
- Lisez attentivement les instructions de montage et suivez-les étape par étape.
- Pour éviter toute rayure, posez une couverture douce sur le sol est suggéré.
- Identifiez, trie et comptez toutes les pièces avec des étiquettes.
- Trouver la position d'installation selon le dessin et l'installer dans les étapes correctes.

AUTRE

- Personnes nécessaires pour l'assemblage : 1-2.
- Temps de montage estimé : 1-1.5 h.

AVERTIR

- Soyez prudent lorsque vous utilisez une perceuse électrique ou un tournevis électrique.
- Veuillez être conscient de ralentir et d'arrêter lorsque la vis est presque serrée.
- N'utilisez pas de produits chimiques corrosifs ou de nettoyants abrasifs pour cet article.
- Poussez, tirez ou tirez cet article avec précaution.

CONSEJOS ÚTILES

ANTES DE EMPEZAR

- Inspeccione el paquete del producto para asegurarse de que la apariencia es buena.
- Lea atentamente las instrucciones de montaje y sígalas paso a paso.
- Para evitar rayas, se sugiere poner una manta suave en el suelo.
- Identifique, clasifique y enumere todas las piezas con etiquetas.
- Averigüe la posición de instalación según el dibujo e instálela en los pasos correctos.

OTROS

- Personas necesarias para el montaje: 1-2.
- Tiempo de montaje estimado: 1-1.5 h.

PRECAUCIÓN

- Tenga cuidado al utilizar un taladro eléctrico o un destornillador eléctrico.
- Tenga en cuenta que debe hacerlo más despacio y detenerse cuando el tornillo esté casi apretado.
- No utilice productos químicos agresivos ni limpiadores abrasivos para este artículo.
- Empuje, tire o arrastre este elemento con cuidado.

SUGGERIMENTI UTILI

PRIMA DI INIZIARE

- Controllare la confezione del prodotto per assicurarsi che sia in buono stato.
- Leggere con attenzione le istruzioni per l'assemblaggio e seguirle passo dopo passo.
- Per evitare graffi al pavimento, suggeriamo di stendervi una coperta morbida.
- Identificare, suddividere e contare tutte le parti con etichetta.
- Trovare la posizione adatta per il montaggio in base al disegno e montare lo scaffale seguendo correttamente i vari passaggi.

ALTRO

- Persone necessarie per l'assemblaggio: 1-2.
- Tempo di assemblaggio stimato: 1-1.5 ora.

ATTENZIONE

- Prestare molta attenzione quando si utilizza un trapano elettrico o un cacciavite elettrico.
- Rallentare con accortezza e fermarsi quando una vite è già sufficientemente serrata.
- Non utilizzare prodotti chimici aggressivi o detergenti abrasivi su questo articolo.
- Spingere, tirare o trascinare questo articolo con cautela.

NÜTZLICHE HINWEISE

⚠️ BEVOR SIE BEGINNEN

- Überprüfen Sie die Produktverpackung auf Schäden.
- Lesen Sie sich die Montageanleitung sorgfältig durch und befolgen Sie sie Schritt für Schritt.
- Um etwaiges Zerkratzen zu vermeiden, wird das Auslegen einer weichen Decke auf dem Boden empfohlen.
- Identifizieren, sortieren und zählen Sie alle Teile mit Tags nach.
- Identifizieren Sie die Montageposition gemäß der Zeichnung und bauen Sie das Regal den richtigen Schritten entsprechend auf.



SONSTIGES

- Für den Zusammenbau erforderliche Anzahl an Menschen: 1-2.
- Ungefähre Montagedauer: 1-1.5 h.

⚠️ VORSICHT

- Seien Sie bei der Verwendung einer Bohrmaschine oder eines Akkuschraubers vorsichtig.
- Bitte vergessen Sie nicht darauf, langsamer zu werden und zu stoppen, sobald die Schraube fast festgezogen ist.
- Verwenden Sie keinerlei aggressive Chemikalien oder scheuernden Reinigungsmittel für dieses Produkt.
- Schieben oder ziehen Sie dieses Produkt vorsichtig.

温馨提示

⚠️ 安装前注意事项

- 检查产品包装, 确保外观良好。
- 仔细阅读安装说明, 按步骤操作。
- 为了避免刮伤, 建议在地板上放一条柔软的毯子。
- 标识、分类和清点所有部件。
- 根据图形找到安装孔位, 按正确步骤安装。



其他:

- 组装所需人员: 1-2人。
- 预计组装时间: 1-1.5小时。

⚠️ 注意:

- 小心使用电钻或电动螺丝刀。
- 当螺丝快要拧紧时, 请注意减速。
- 不要使用任何刺激性化学物质或清洗剂。
- 当推、拉或拖动产品时, 注意小心谨慎, 防止损坏。

役に立つヒント

⚠️ 組立の場所を確保し、順番通りに組み立てる

- 組立場所 (充分広くて平たい場 所) を確保してください。
- 床や壁、商品を傷つけないように、商品の下に厚めの布や段ボールなどを敷いてください。
- 組立の順番を守らないと、組立できなくなったり、商品を傷つけたりします。



その他

- 組み立てに必要な人: 1-2。
- 組立時間: 約1-1.5時間。

⚠️ 部品を確認する

- ネジ類などの部品番号、形状を説明書の部品一覧で確認してください。
- 部品をなくさないように纏めて置いてください。
- 部品を取り出すときに使う分だけ取り出してください。

Detailed Installation for Accessory A B

Installation détaillée pour l'accessoire A B
Detaillierte Installation des Zubehörs A B
Installazione dettagliata per l'accessorio A B
Instalación detallada del accesorio A B
カムロック取り付け方
配件A、B详细安装

1

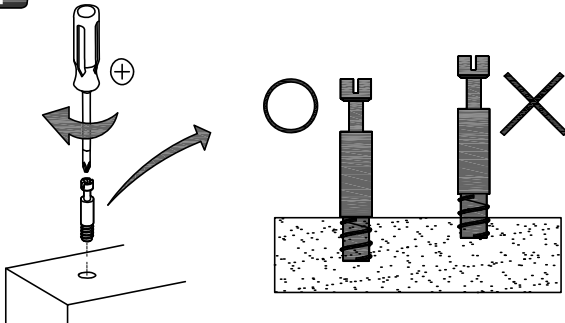

Screw cam dowel on the panel.
Vissez la goupille de came au panneau.
Nockendübel auf die Platte schrauben.
Avvitare il tassello a camme sul pannello.
tornillo de pasador de leva en el panel.
カムロックネジを部品に取り付ける。
螺杆用十字螺丝刀装入对应的预留孔内

Place another panel via the dowel.
Placez un autre panneau par le goujon.
Setzen Sie eine weitere Platte über den Dübel ein.
Posizionare un altro pannello tramite il tassello.
Coloque otro panel a través del pasador.
カムロックネジをカムロック穴に差し込む。
螺杆插入对应孔位，将两块板材对接起来。

2

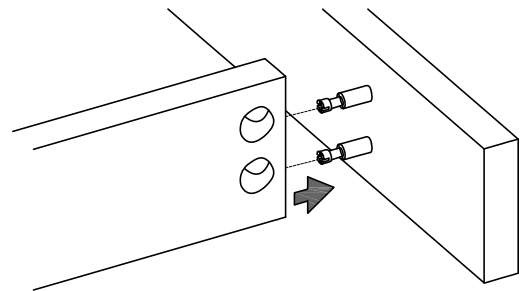

3

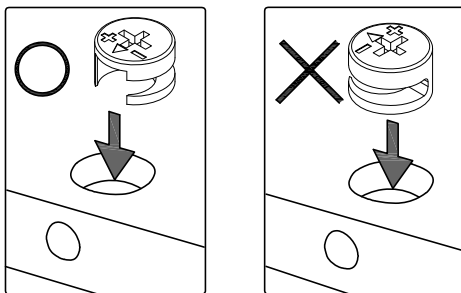

Pay attention to the direction of cam lock when putting it into hole.

Faites attention à la direction du verrou à came en entrant dans le trou.

Achten Sie auf die Richtung des Nockenschlosses, wenn Sie es in das Loch stecken.

Fare attenzione alla direzione della serratura a camme quando lo si inserisce nel foro.

Preste atención a la dirección de la leva de fijación al insertarla en el orificio.

カムロックネジの方向にカムロックの穴の穴の向きを合わせ取り付け。

装入锁扣圆盘，注意锁扣圆盘的方向；

Tighten up cam lock clockwise until it stops.
Serrez le verrou à came dans le sens des aiguilles d'une montre jusqu'à ce qu'il s'arrête.
Ziehen Sie die Nockenverriegelung im Uhrzeigersinn bis zum Anschlag an.
Stringere la serratura a camme in senso orario fino all'arresto.
Apriete la leva de fijación en sentido horario hasta el tope.
カムロックをドライバーで締め固定する。
顺时针旋转锁扣圆盘并锁紧。

4

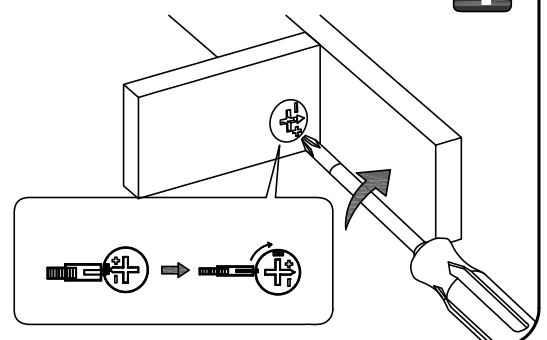



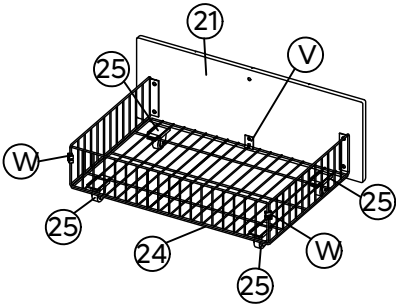
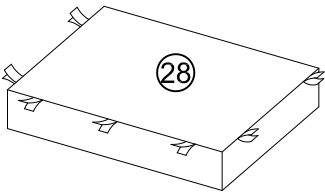
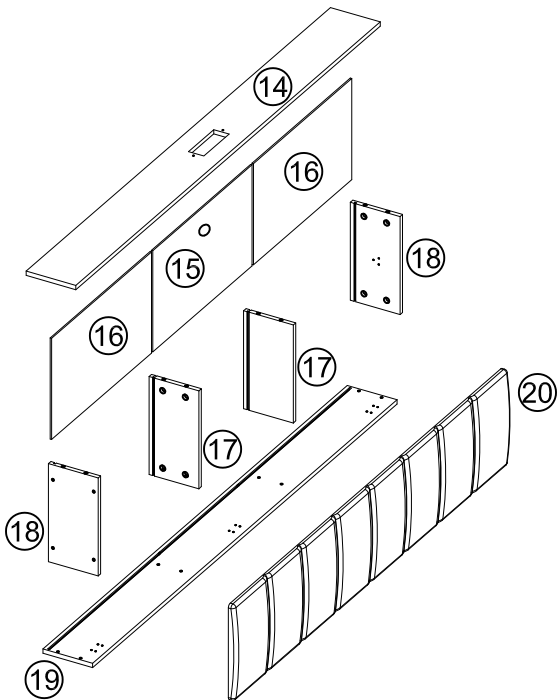
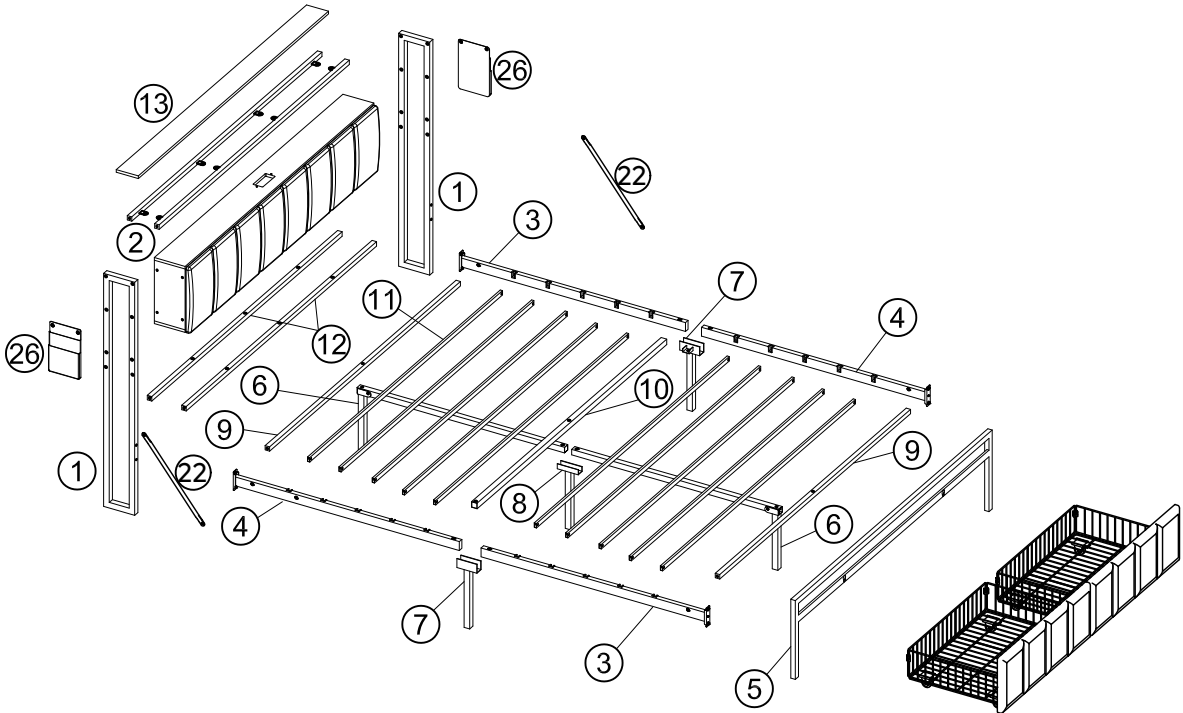





ASSEMBLY INSTRUCTION

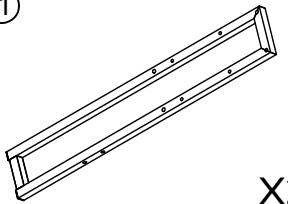
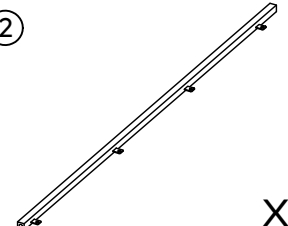
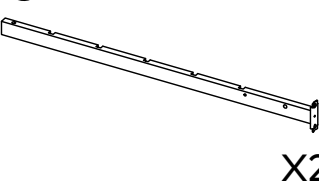
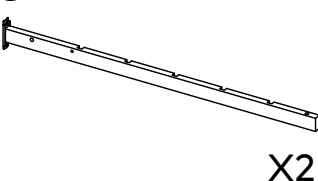
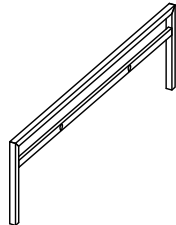
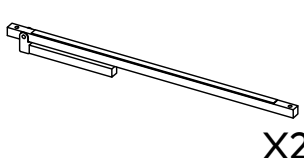

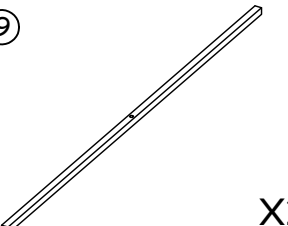
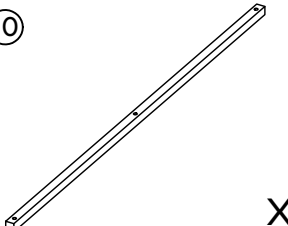
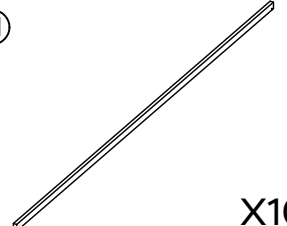
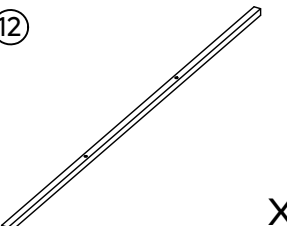
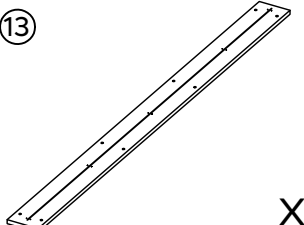
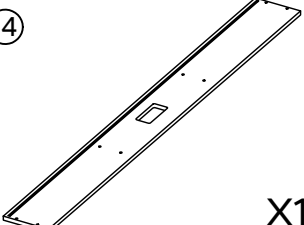
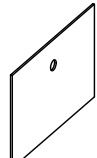
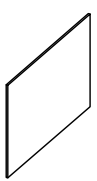
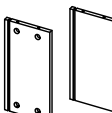
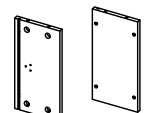
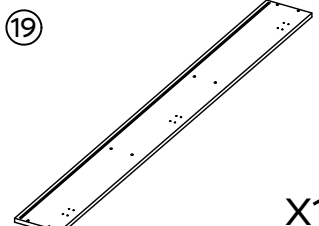
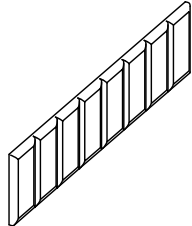
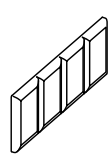
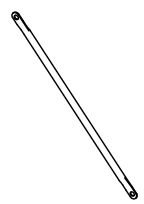
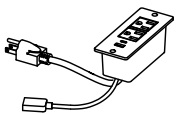
PART LIST

STÜCKLISTE
LISTE DES PIÈCES
ELENCO DEI PEZZI

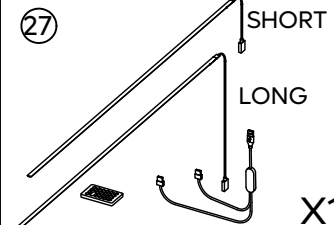
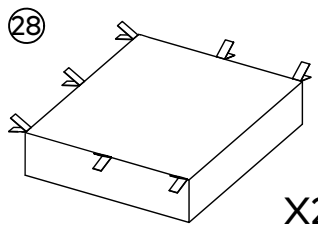

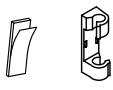









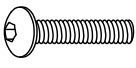

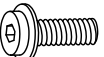

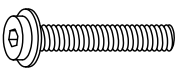

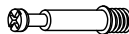

LISTA DE PIEZAS
部品の確認
部件清單

①  X2	②  X2	③  X2	④  X2
⑤  X1	⑥  X2	⑦  X2	⑧  X1
⑨  X2	⑩  X1	⑪  X10	⑫  X2
⑬  X1	⑭  X1	⑮  X1	⑯  X2
⑰  X2	⑱  X2	⑲  X1	⑳  X1
㉑  X2	㉒  X2	㉓  X1	㉔  X2
㉕  X8	㉖  X2	㉗  X1	㉘  X2
㉚  X5	㉛  X11		

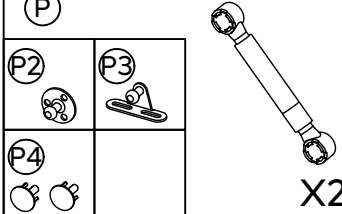
ACCESSORY LIST

ZUBEHÖRLISTE
LISTE DES ACCESSOIRES
ELENCO DEGLI ACCESSORI

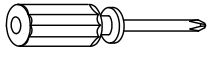
LISTA DE ACCESORIOS
付属品部品の確認
配件清單

<p>(A)</p>  <p>M6*10mm X10 (+1)</p>	<p>(B)</p>  <p>M6*15mm X10 (+1)</p>	<p>(C)</p>  <p>M6*28mm X2</p>	<p>(D)</p>  <p>M6*35mm X8 (+1)</p>
<p>(E)</p>  <p>M8x20mm X8 (+1)</p>	<p>(F)</p>  <p>M8x35mm X16 (+2)</p>	<p>(G)</p>  <p>M8x50mm X4</p>	<p>(H)</p>  <p>M8x60mm X3</p>
<p>(I)</p>  <p>3*12mm X26 (+2)</p>	<p>(J)</p>  <p>4*14mm X22 (+2)</p>	<p>(K)</p>  <p>M6*20mm X2</p>	<p>(L)</p>  <p>S5mm X1</p>
<p>(M)</p>  <p>S4mm X1</p>	<p>(N)</p>  <p>X16</p>	<p>(O)</p>  <p>X16</p>	<p>(P)</p>  <p>X2</p>
<p>(Q)</p>  <p>X3</p>	<p>(R)</p>  <p>X2</p>	<p>(S)</p>  <p>X4</p>	<p>(T)</p>  <p>X8</p>
<p>(U)</p>  <p>X1</p>	<p>(V)</p>  <p>X2</p>	<p>(W)</p>  <p>X1</p>	

※Remote control battery installation procedure

※Étapes d'installation de la batterie à télécommande

※ Schritte zur Installation der Batterie der Fernbedienung

※Passaggi di installazione della batteria del telecomando

※Pasos de instalación de la batería de control remoto

※リモコンの電池取り付け手順

※遥控器电池安装步骤

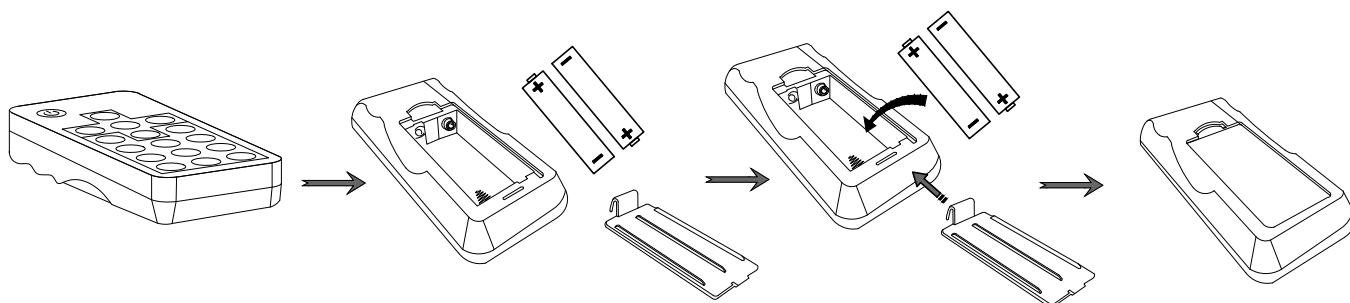

1. The battery compartment is located on the back end of the remote control.
2. Press and slide the battery door open.
3. Insert 2 AAA batteries, checking that the + and - sides of the battery match inside the battery compartment.
4. Replace the battery compartment door.
5. Batteries are not included in the package due to safety transportation.

Note:

- A. Do not mix old and new batteries together in the remote.
- B. Do not mix alkaline, standard(carbon-zinc), or rechargeable (NiCad, NiMh, etc.) batteries together.

-
- 1.Le compartiment de la batterie est situé à l'arrière de la télécommande.
 - 2.Appuyez et faites glisser la porte de la batterie pour l'ouvrir.
 - 3.Insérez 2 piles AAA et vérifiez si le côté + et le côté - de la batterie correspondent. Dans le compartiment de la batterie.
 - 4.Remplacez le couvercle de la batterie.
 - 5.En raison du transport sûr, la batterie n'est pas incluse dans l'emballage.

Remarque :

- A.Ne mélangez pas les anciennes et les nouvelles batteries dans la télécommande.
- B.Ne mélangez pas les piles alcalines, standard (zinc carbone) ou rechargeables (NiCad, NiMh, etc.).

-
- 1.Das Batteriefach befindet sich am hinteren Ende der Fernbedienung.
 - 2.Drücken und schieben Sie die Batterietür, um sie zu öffnen.
 - 3.Setzen Sie 2 AAA-Batterien ein und überprüfen Sie, ob die +-Seite und --Seite der Batterie übereinstimmen, Im Batteriefach.
 - 4.Ersetzen Sie die Batterietür.
 - 5.Aufgrund des sicheren Transports ist die Batterie nicht im Paket enthalten.

Hinweis:

- A.Mischen Sie alte und neue Batterien nicht in der Fernbedienung.
- B.Mischen Sie keine Alkali-, Standard- (Kohlenstoff-Zink) oder wiederaufladbaren (NiCad, NiMh usw.) Batterien zusammen.

1. Il vano batteria si trova nella parte posteriore del telecomando.
 2. Premere e far scorrere lo sportello della batteria per aprirlo.
 3. Inserire 2 batterie AAA e verificare se il lato + e il lato - della batteria corrispondono.
- Nel vano batteria.
4. Sostituire lo sportello della batteria.
 5. A causa del trasporto sicuro, la batteria non è inclusa nel pacchetto.

Nota:

- A. Non mescolare insieme batterie vecchie e nuove nel telecomando.
 - B. Non mescolare insieme batterie alcaline, standard (carbon zinco) o ricaricabili (NiCad, NiMh, ecc.).
-

1. El compartimento de la batería se encuentra en la parte trasera del mando a distancia.
 2. Presione y deslice la puerta de la batería para abrirla.
 3. Inserte 2 pilas AAA y compruebe si el lado + y el lado - de la batería coinciden.
- En el compartimento de la batería.
4. Reemplace la puerta de la batería.
 5. Debido a la seguridad del transporte, la batería no está incluida en el paquete.

Nota:

- A. No mezcle las baterías viejas y nuevas en el mando a distancia.
 - B. No mezcle baterías alcalinas, estándar (zinc de carbono) o recargables (NiCad, NiMh, etc.).
-

1. 電池室はリモコンの後ろ側にあります。
2. 電池ドアを押してスライドさせて開けます。
3. 2本のAAA電池を、電池室内の+と-が一致するように挿入します。
4. 電池室のドアを元に戻します。
5. 安全輸送のため、電池をパッケージに入れしないでください。

注意:

- A. 古い電池と新しい電池を一緒に使用しないでください。
 - B. アルカリ電池、標準（炭酸亜鉛）電池、充電式（ニッカド、ニッケル水素など）電池を混ぜて使用しないでください。
-

1. 电池舱位于遥控器的后端。
2. 按下并滑动打开电池舱门。
3. 插入两节AAA电池，检查电池的正极和负极是否与电池内部隔间匹配。
4. 合上电池舱门。
5. 出于运输安全考虑，包装中不包括电池。



注意:

- A. 不要在遥控器中将新旧电池混在一起。
- B. 不要将碱性、标准（碳锌）或可充电（镍镉、镍氢等）电池混合在一起。

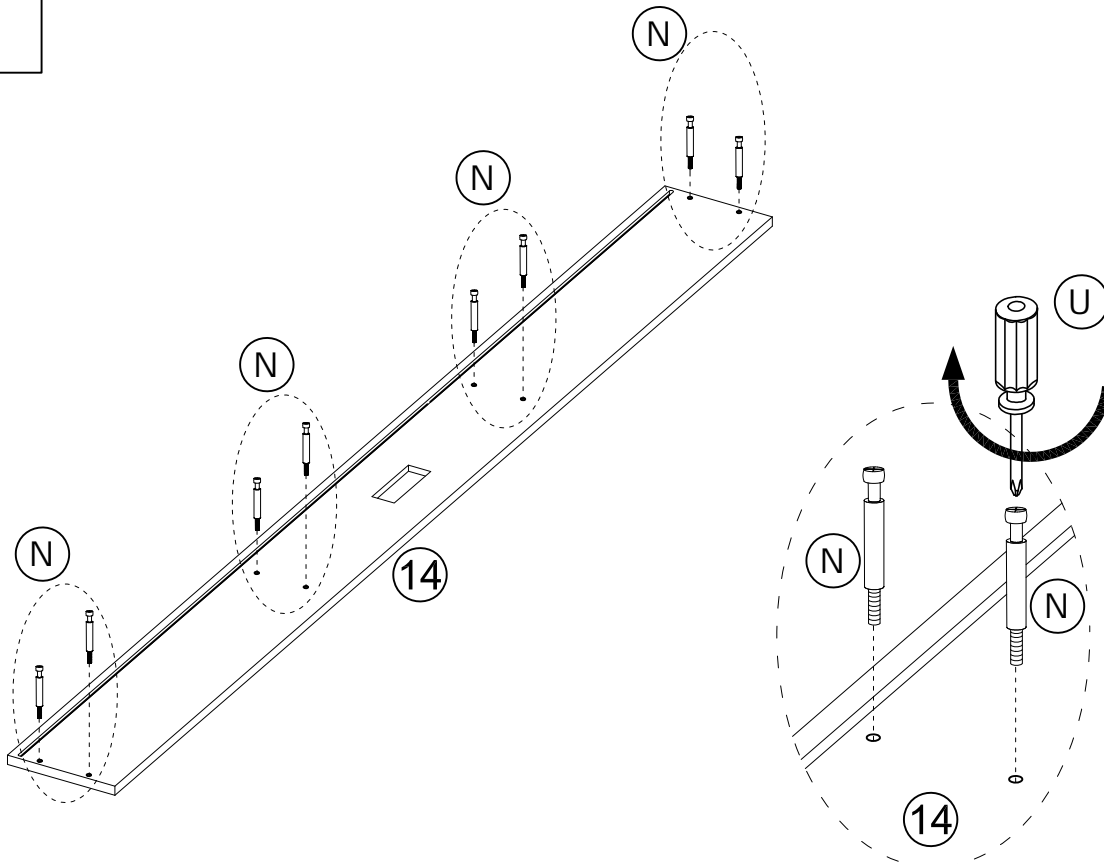
1





100% tighten
 100% serré
 100% festziehen
 Serraggio al 100%
 100% reforzado
 100%締め付け
 100%锁紧

	(N) X8
	(U) X1

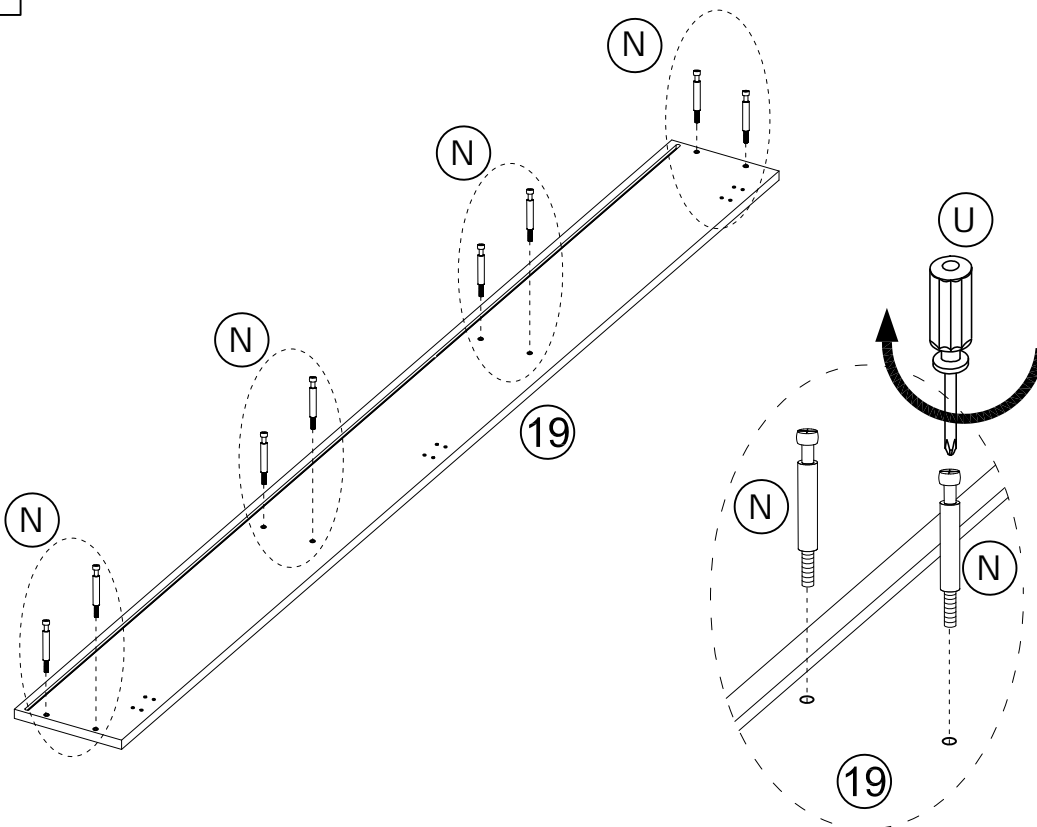
2





100% tighten
 100% serré
 100% festziehen
 Serraggio al 100%
 100% reforzado
 100%締め付け
 100%锁紧

	(N) X8
	(U) X1

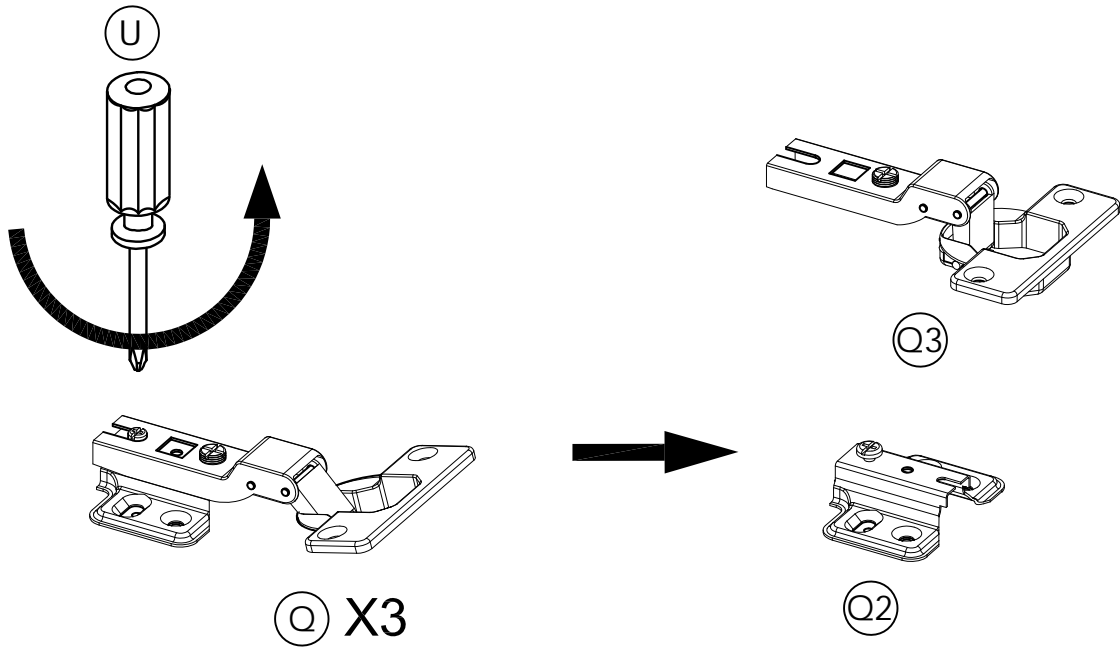
3



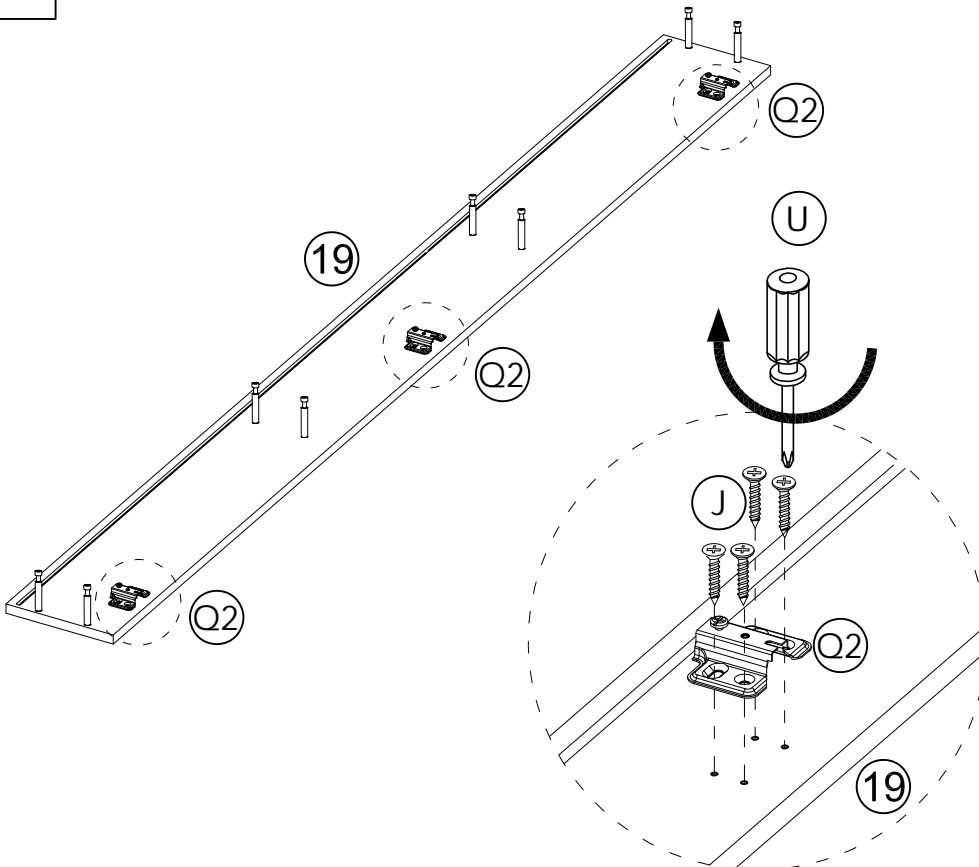

	Ⓚ X3
	Ⓚ X1

4



100%
 100% tighten
 100% serré
 100% festziehen
 Serraggio al 100%
 100% reforzado
 100%締め付け
 100%锁紧

		Ⓚ X3
4*14		Ⓚ X12
		Ⓚ X1

5

100% tighten
 100% serré
 100% festziehen
 Serraggio al 100%
 100% reforzado
 100%締め付け
 100%锁紧

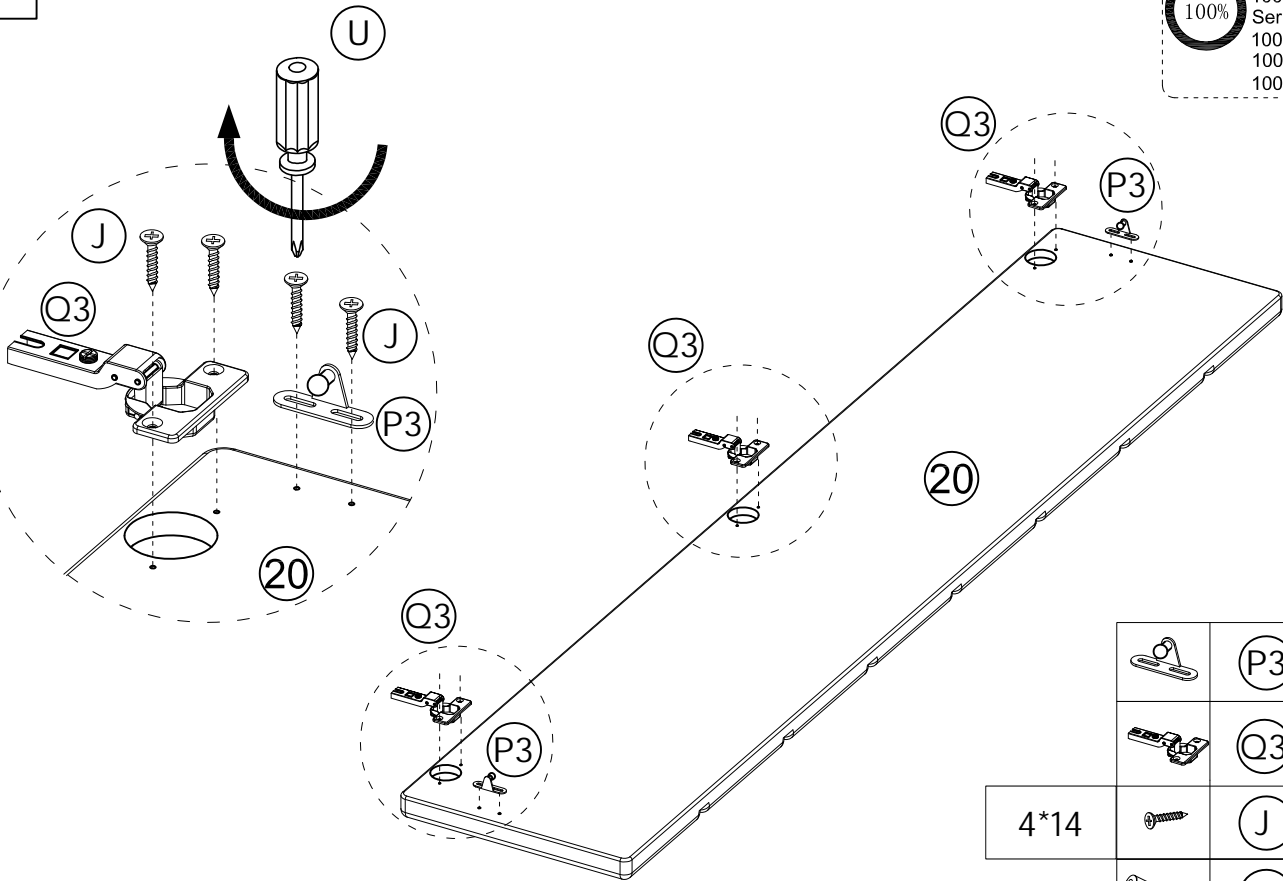

		P3	X2
		Q3	X3
4*14		J	X10
		U	X1

6



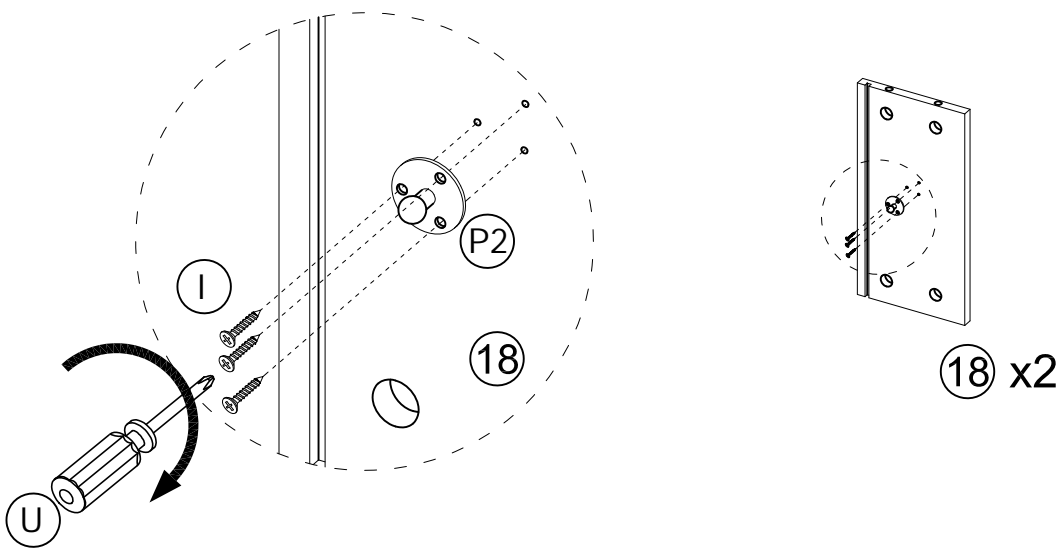

100% tighten
 100% serré
 100% festziehen
 Serraggio al 100%
 100% reforzado
 100%締め付け
 100%锁紧

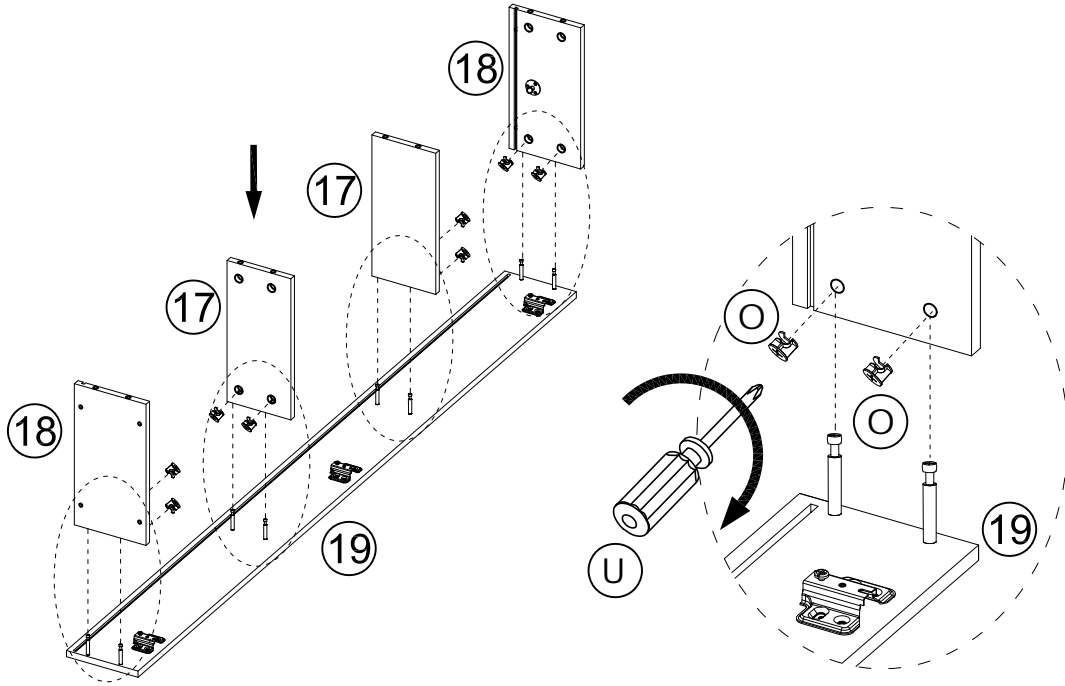

3*12		I	X6
		P2	X2
		U	X1

7





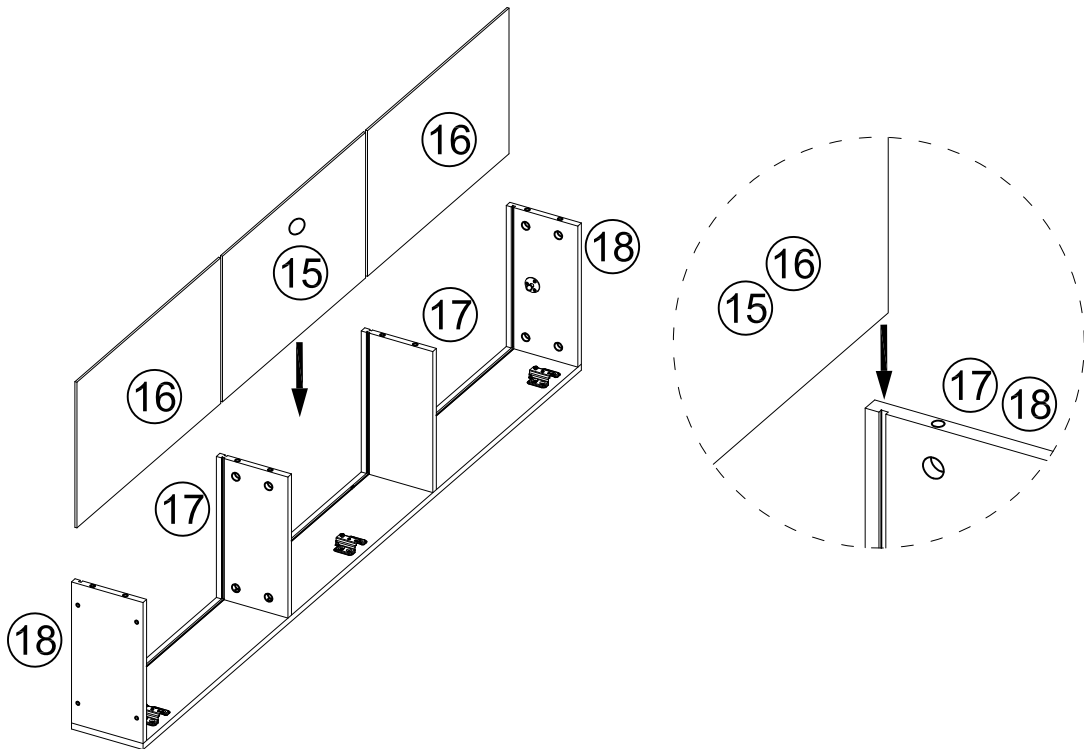

	 X8
	 X1

8

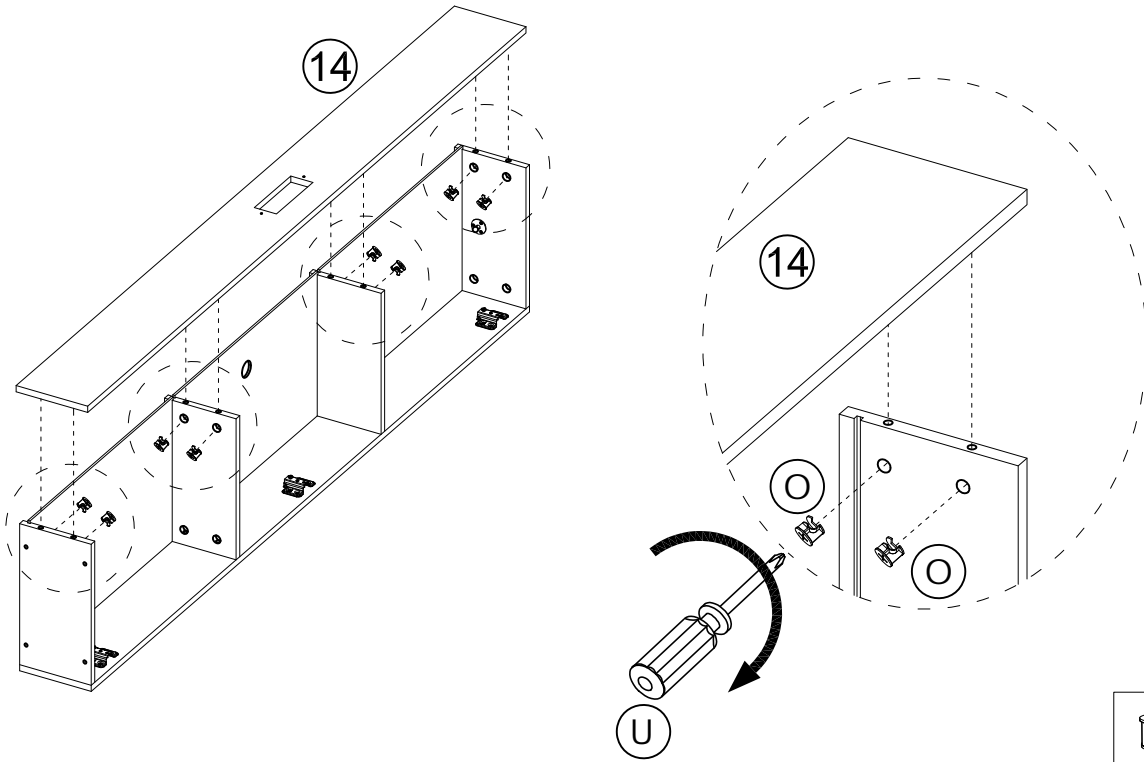

9





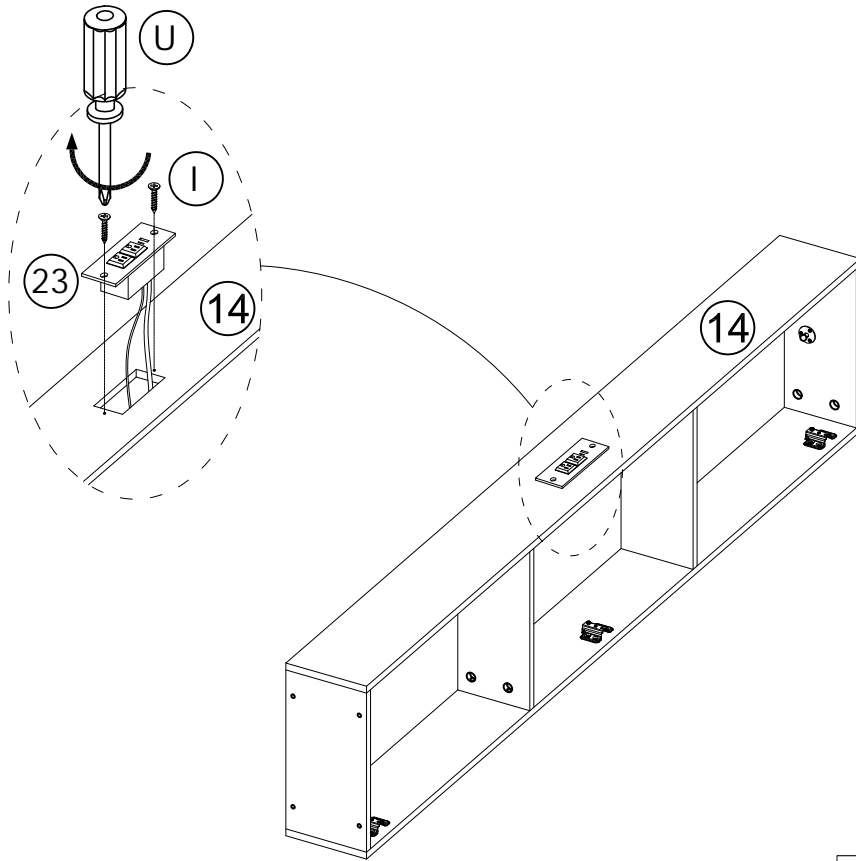

	 X8
	 X1

10





100% tighten
 100% serré
 100% festziehen
 Serraggio al 100%
 100% reforzado
 100%締め付け
 100%锁紧

3*12		 X2
		 X1

11

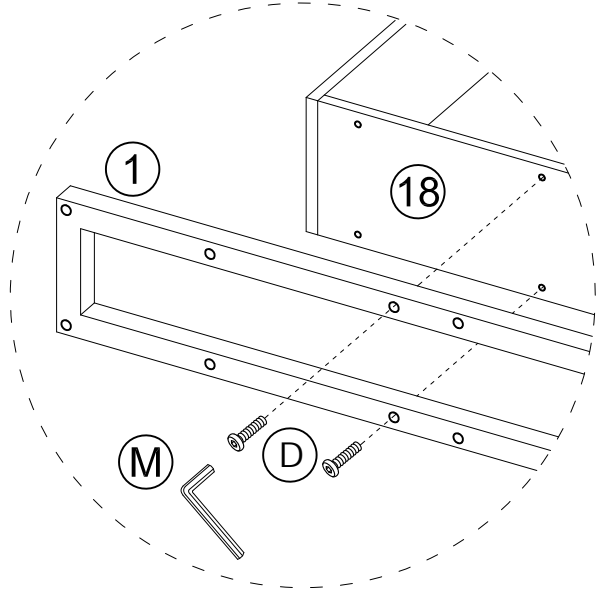
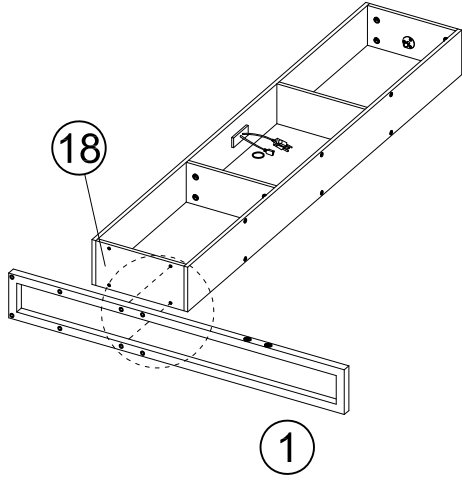
80% tighten
 80 % serré
 80% festziehen
 Serraggio al 80%
 80% reforzado
 80% 締め付け
 80% 锁紧





M6*35		(D) X2
		(M) X1

12

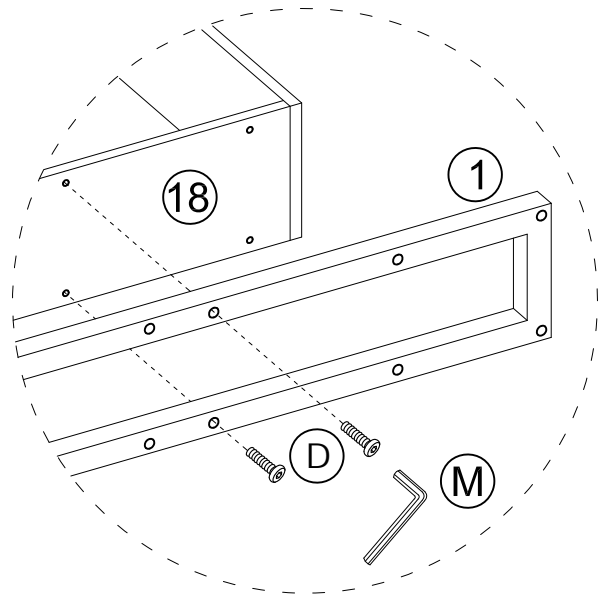
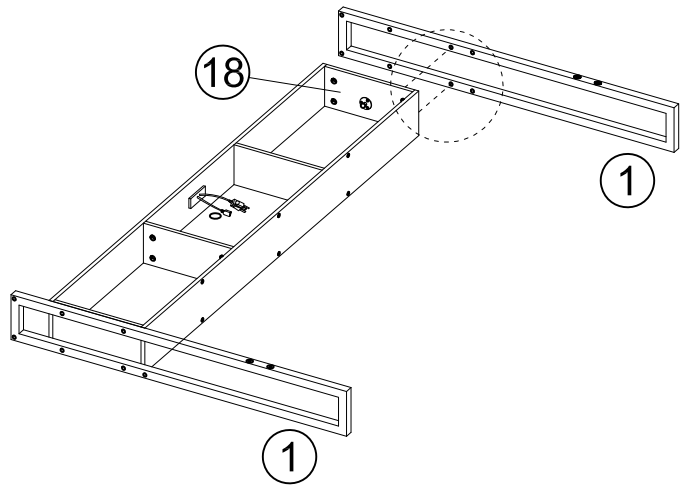
80% tighten
 80 % serré
 80% festziehen
 Serraggio al 80%
 80% reforzado
 80% 締め付け
 80% 锁紧



M6*35		(D) X2
		(M) X1

13

80% tighten
 80 % serré
 80% festziehen
 Serraggio al 80%
 80% reforzado
 80% 締め付け
 80% 锁紧

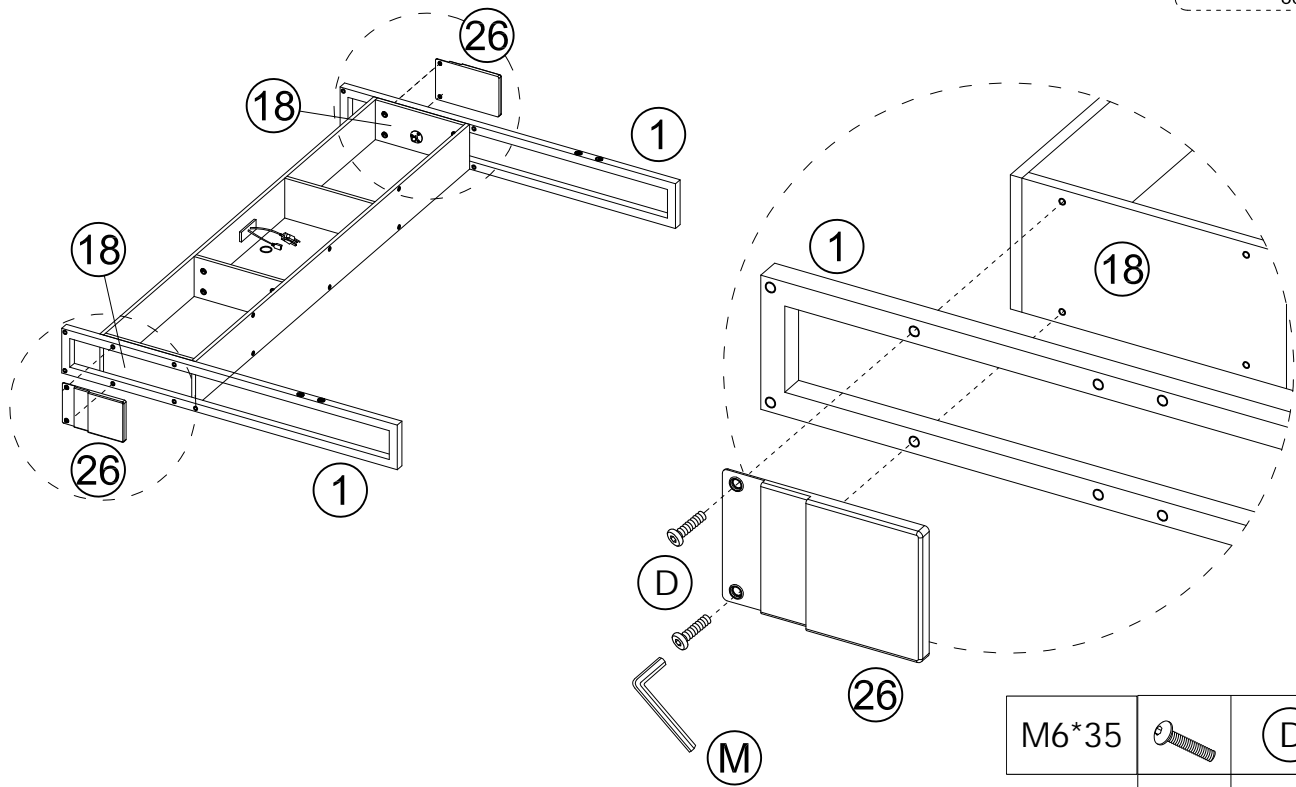

M6*35		(D) X4
		(M) X1

14

80% tighten
 80 % serré
 80% festziehen
 Serraggio al 80%
 80% reforzado
 80% 締め付け
 80% 锁紧

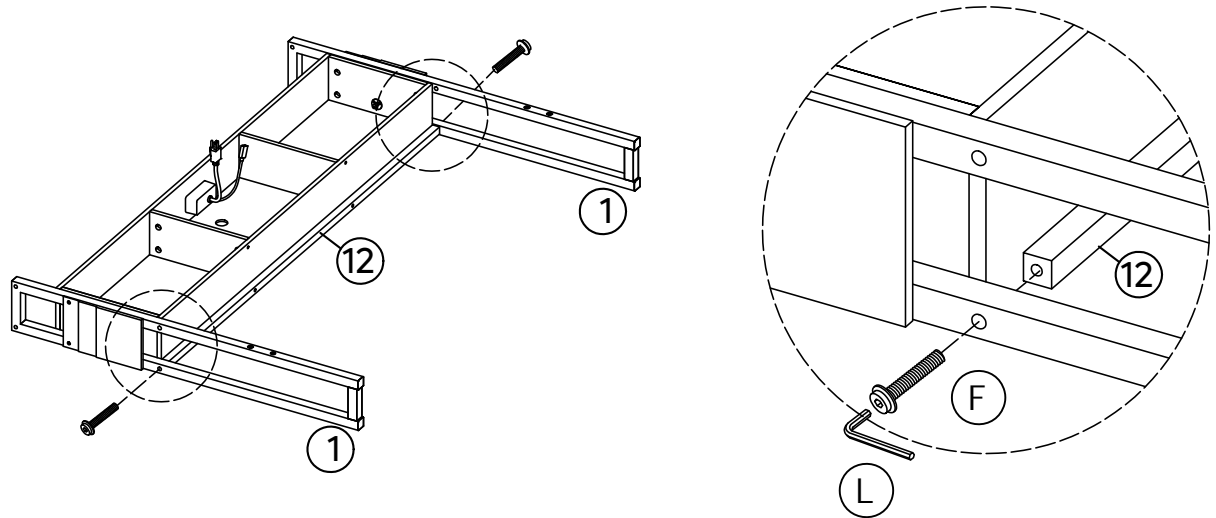

M8*35		(F) X2
		(L) X1

15

100% tighten
 100% serré
 100% festziehen
 Serraggio al 100%
 100% reforzado
 100% 締め付け
 100% 锁紧

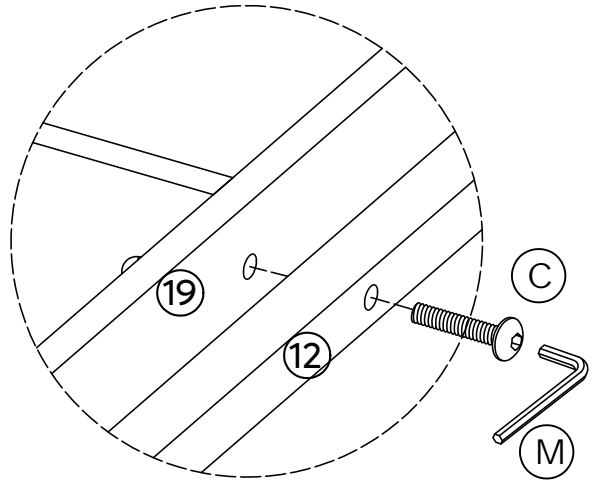
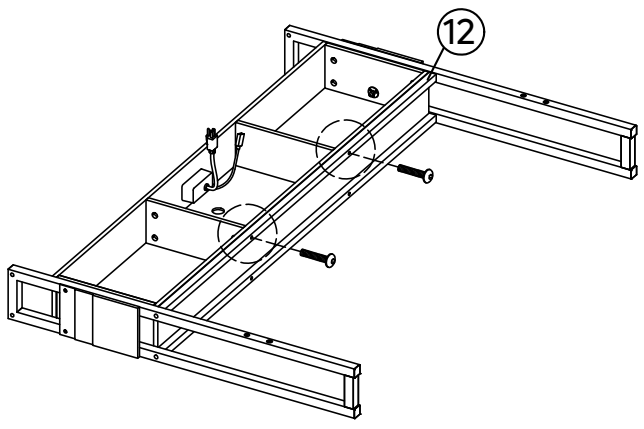

M6*28		(C) X2
		(M) X1

16

100% tighten
 100% serré
 100% festziehen
 Serraggio al 100%
 100% reforzado
 100% 締め付け
 100% 锁紧

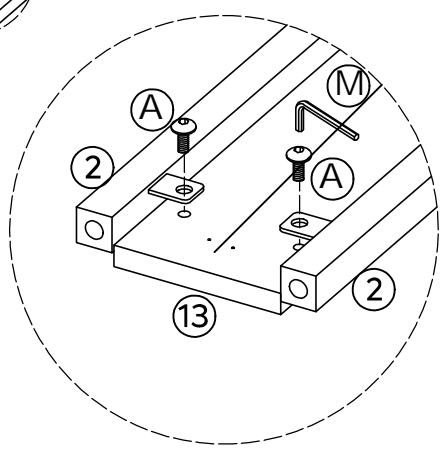
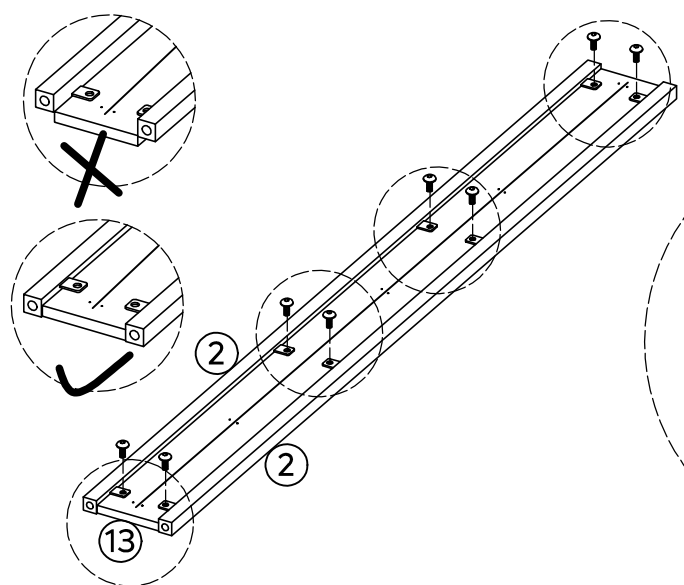



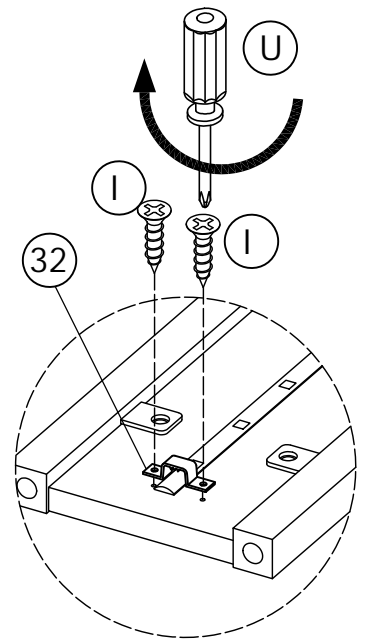
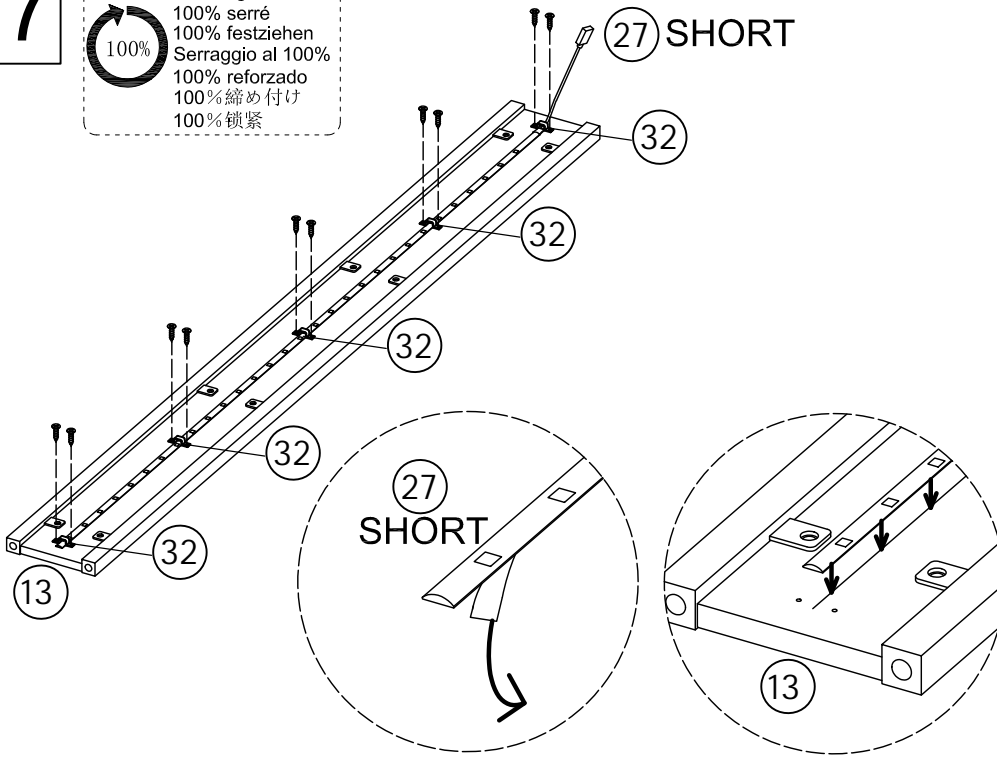

M6*10		(A) X8
		(M) X1

17



 100% tighten
 100% serré
 100% festziehen
 Serraggio al 100%
 100% reforzado
 100%締め付け
 100%锁紧



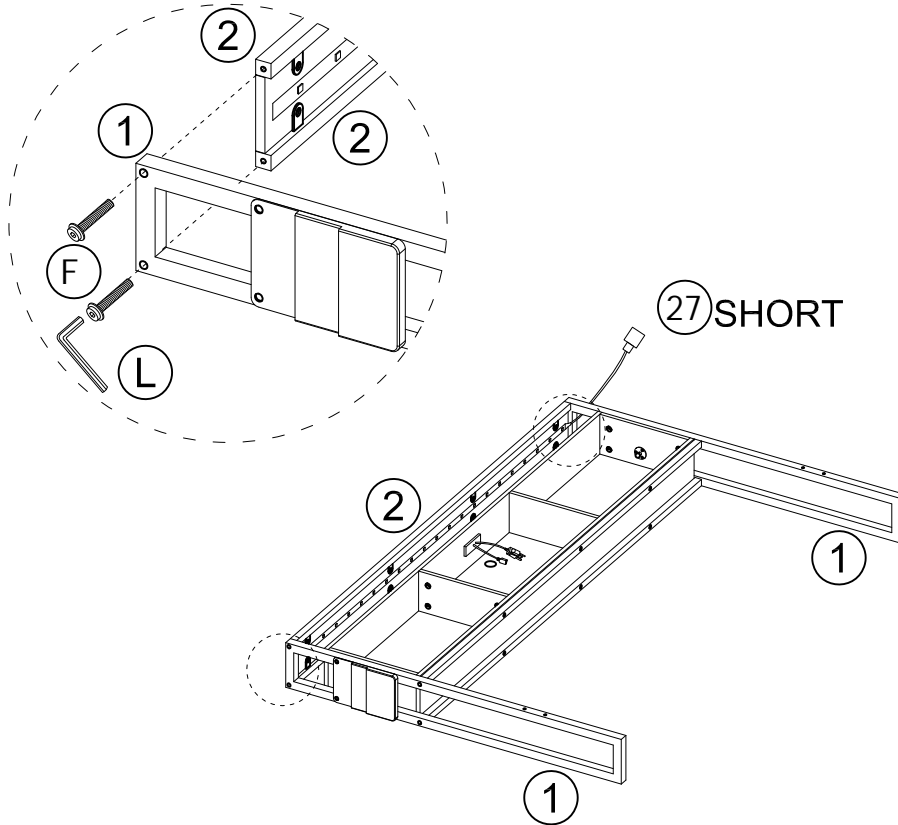

	(32) X5
 SHORT	(27) X1
3*12 	(I) X10
	(U) X1

18



 100% tighten
 100% serré
 100% festziehen
 Serraggio al 100%
 100% reforzado
 100%締め付け
 100%锁紧



M8*35 	(F) X4
	(L) X1

19

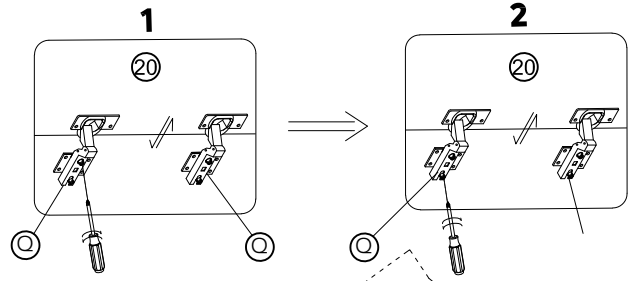
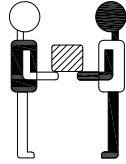
- ※ Two persons are needed.
- ※ Deux personnes sont nécessaires.
- ※ Zwei Personen sind erforderlich.
- ※ Sono necessarie due persone.
- ※ Se necesitan dos personas.
- ※ 必ず2人で作業してください。
- ※ 需要另外1个人协助。



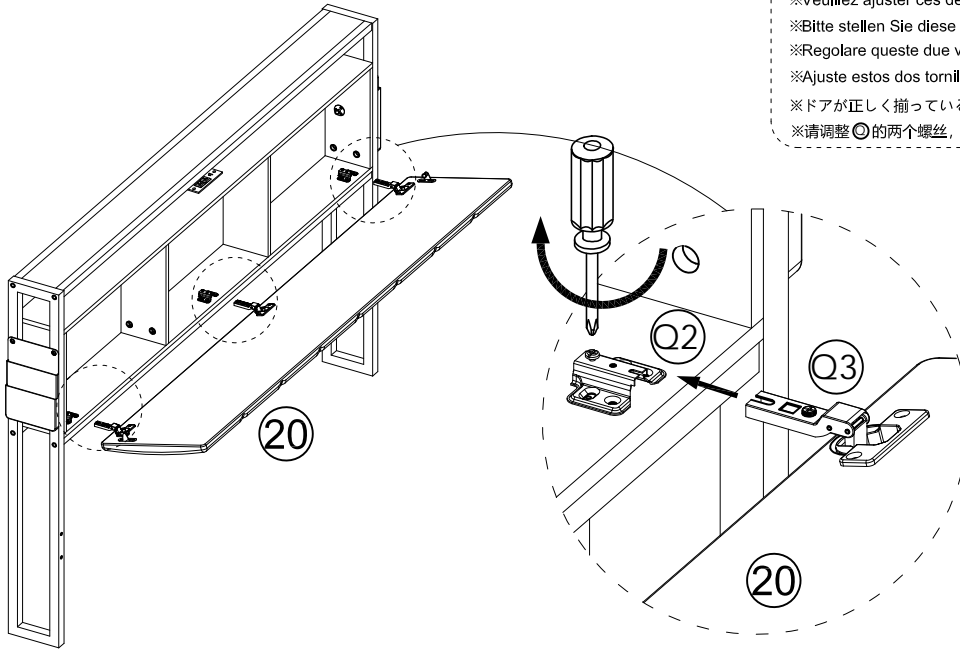

- ※Please adjust these two screws of Part 20 to make the door well-aligned.
- ※Veuillez ajuster ces deux vis de la pièce 20 pour que la porte soit bien installée.
- ※Bitte stellen Sie diese beiden Schrauben von Teil 20 so ein, dass die Tür gut eingestellt ist.
- ※Regolare queste due viti della parte 20 per rendere la porta ben allineata.
- ※Ajuste estos dos tornillos de la pieza 20 para que la puerta esté bien alineada.
- ※ドアが正しく揃っていることを確認するには、部品 20 の2本のねじを調整してください。
- ※请调整 20 的两个螺丝，使门缝平齐一致。

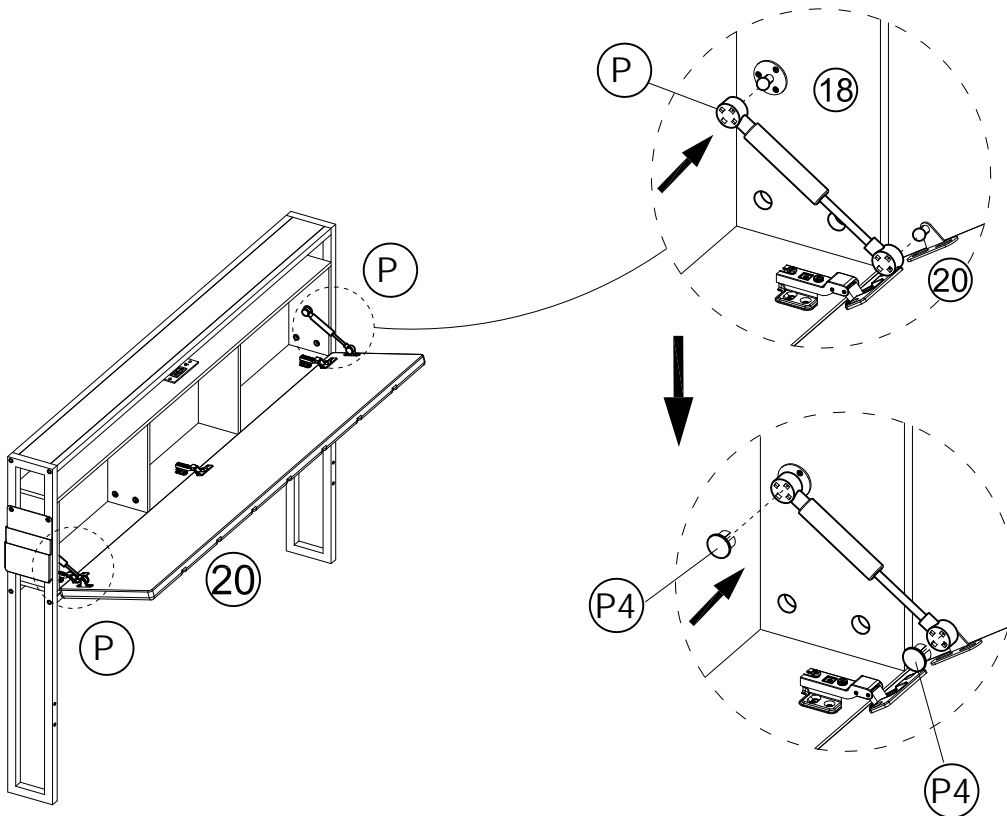

	(U) X1
---	--------

20



	(P) X2
	(P4) X4

21

※ Two persons are needed.
 ※ Deux personnes sont nécessaires.
 ※ Zwei Personen sind erforderlich.
 ※ Sono necessarie due persone.
 ※ Se necesitan dos personas.
 ※ 必ず2人で作業してください。
 ※ 需要另外1个人协助。

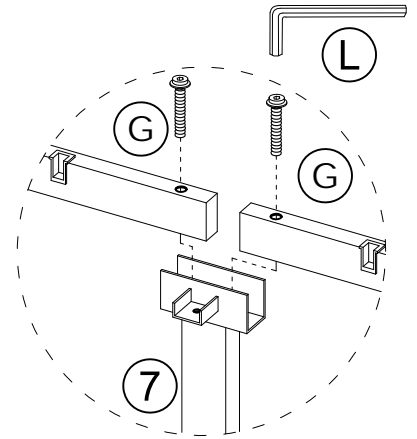
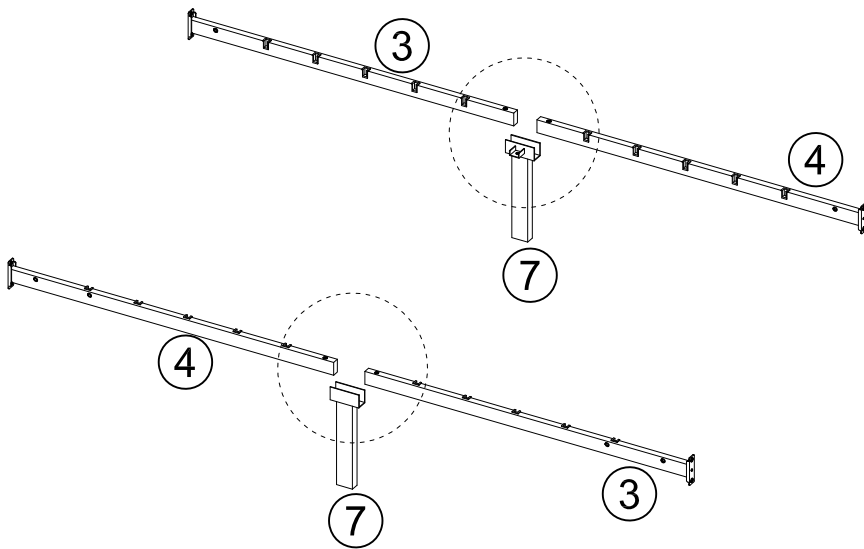
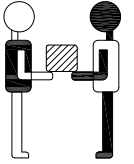

M8*50		(G) X4
		(L) X1

22

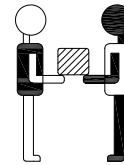

※ Two persons are needed.
 ※ Deux personnes sont nécessaires.
 ※ Zwei Personen sind erforderlich.
 ※ Sono necessarie due persone.
 ※ Se necesitan dos personas.
 ※ 必ず2人で作業してください。
 ※ 需要另外1个人协助。

100% tighten
 100% serré
 100% festziehen
 Serraggio al 100%
 100% reforzado
 100% 締め付け
 100% 锁紧

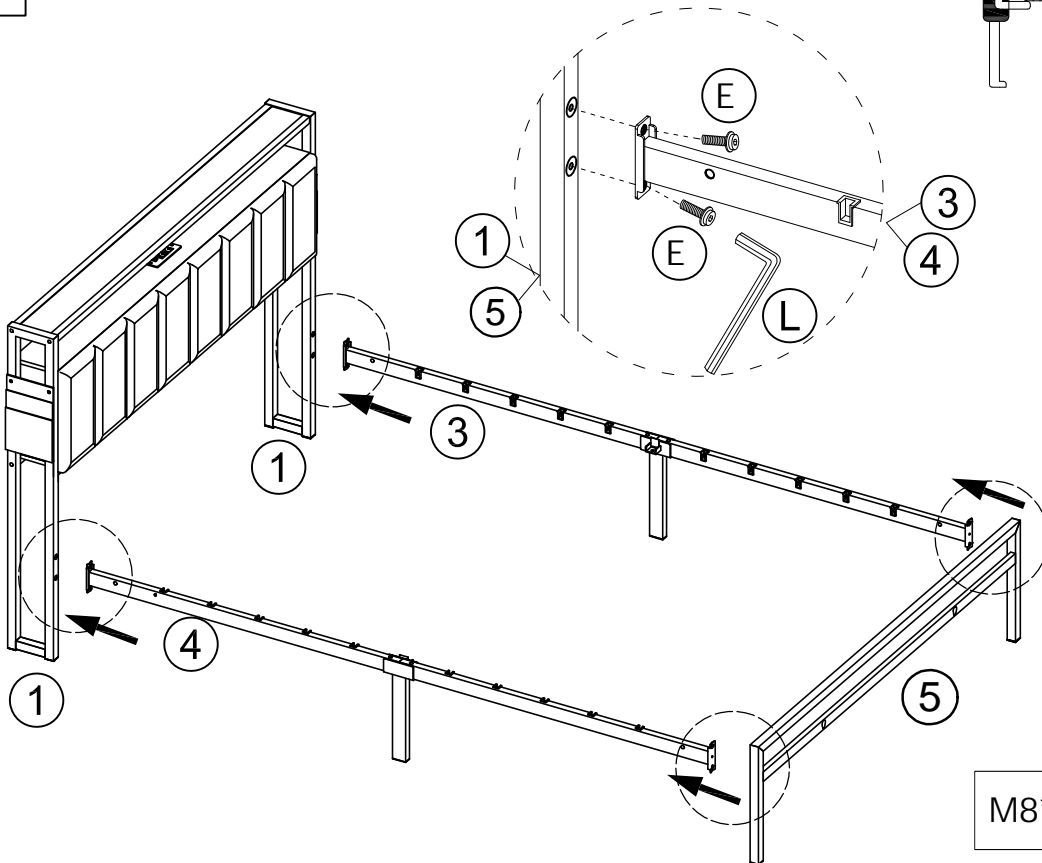

M8*20		(E) X8
		(L) X1

23

100% tighten
 100% serré
 100% festziehen
 Serraggio al 100%
 100% reforzado
 100%締め付け
 100%锁紧

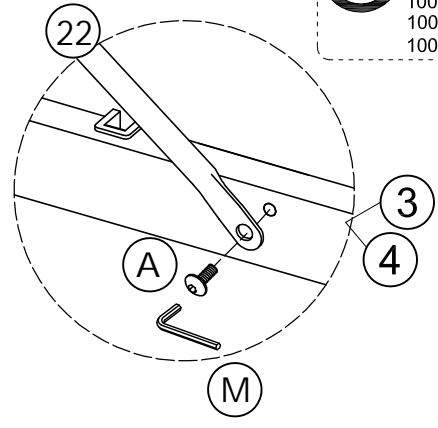
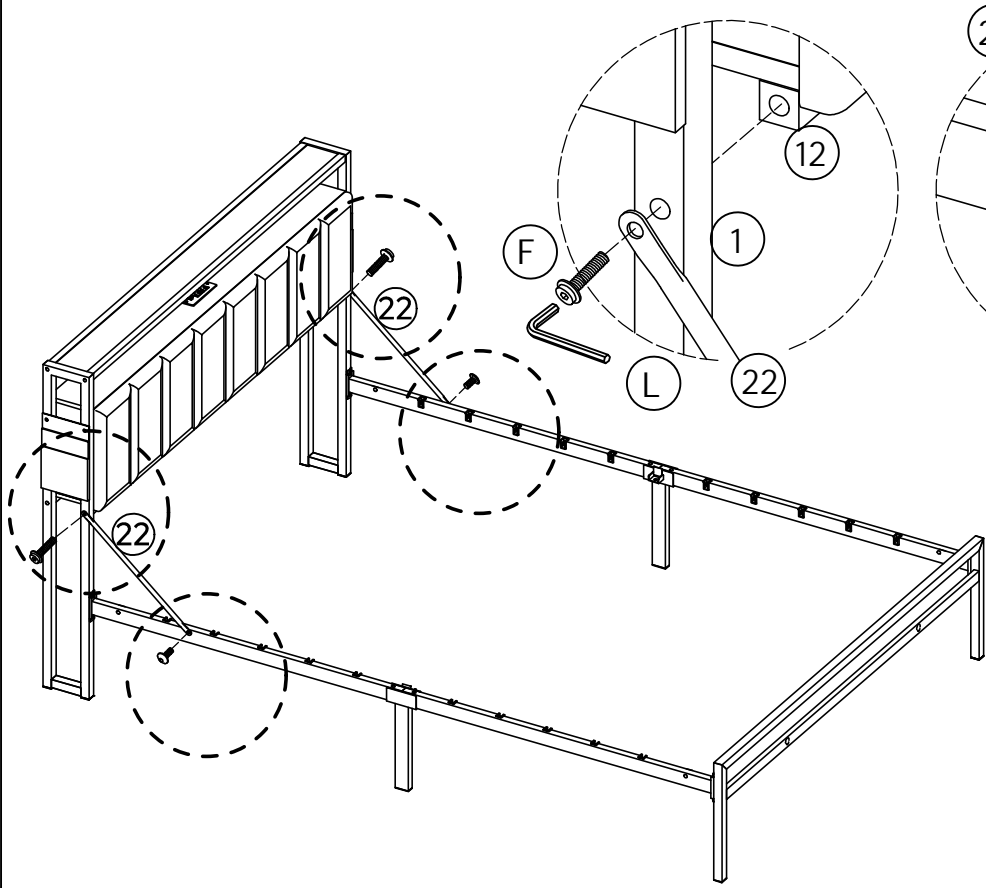

M6*10		(A) X2
		(M) X1
M8*35		(F) X2
		(L) X1

24

100% tighten
 100% serré
 100% festziehen
 Serraggio al 100%
 100% reforzado
 100%締め付け
 100%锁紧

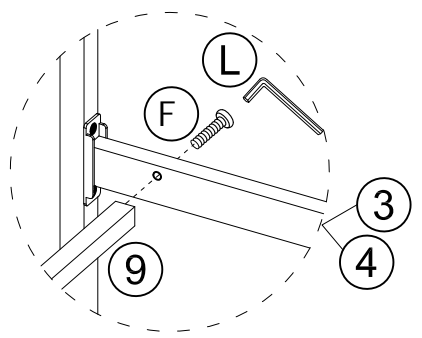
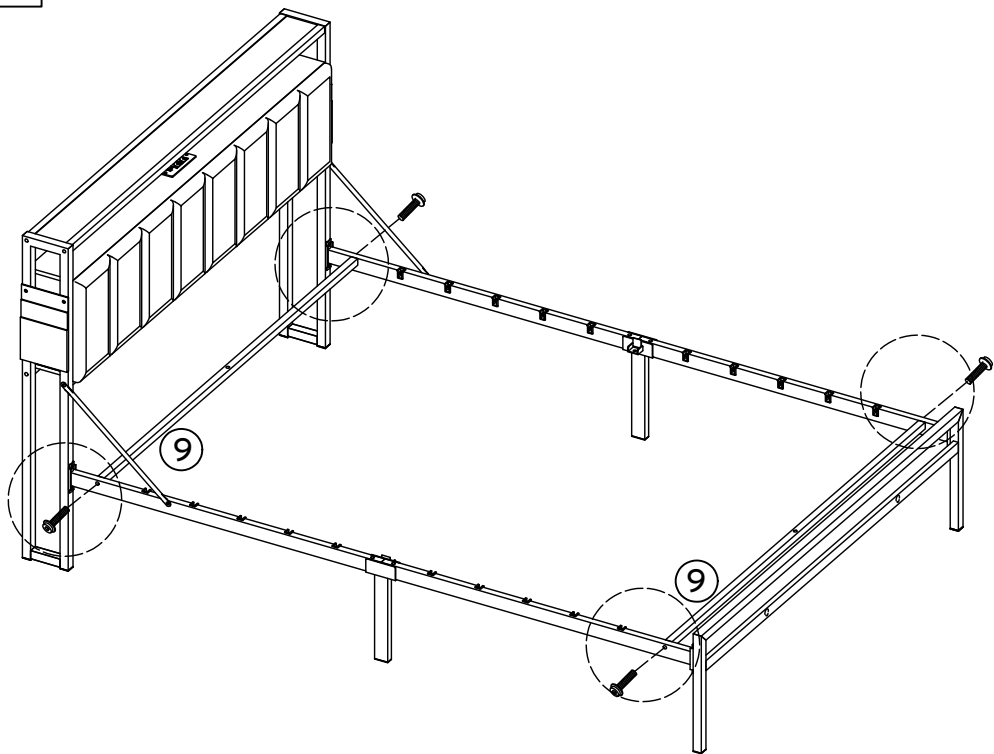

M8*35		(F) X4
		(L) X1

25

※ Two persons are needed.
 ※ Deux personnes sont nécessaires.
 ※ Zwei Personen sind erforderlich.
 ※ Sono necessarie due persone.
 ※ Se necesitan dos personas.
 ※ 必ず2人で作業してください。
 ※ 需要另外1个人协助。

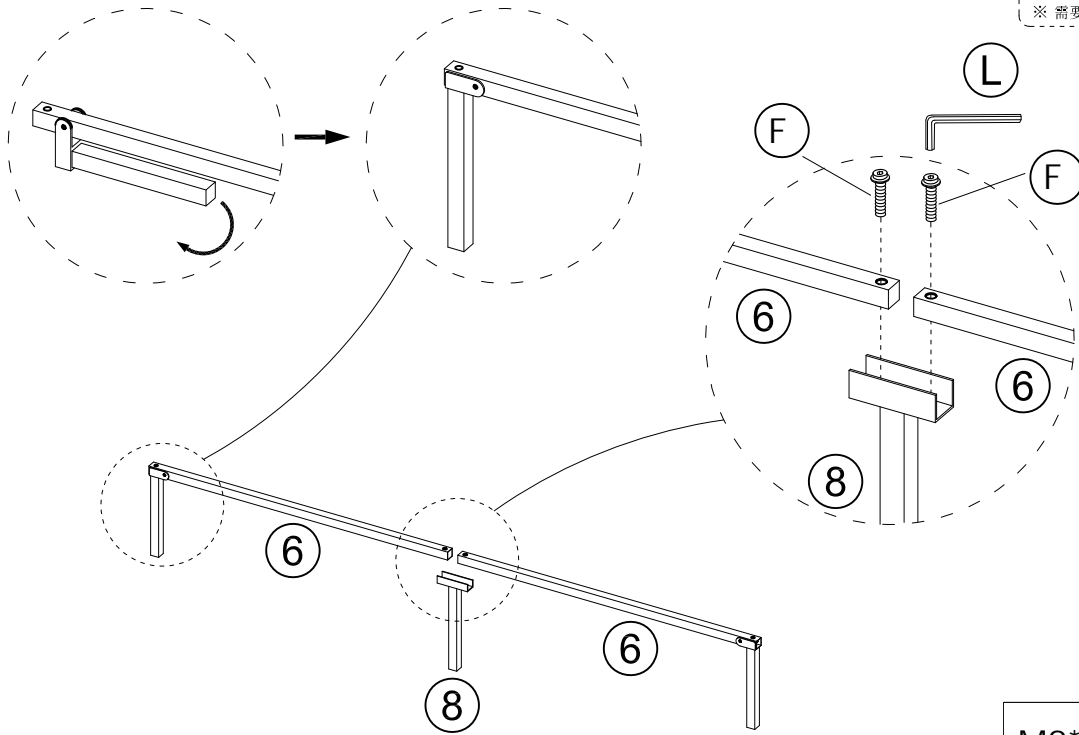
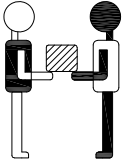

M8*35		(F) X2
		(L) X1

26

100% tighten
 100% serré
 100% festziehen
 Serraggio al 100%
 100% reforzado
 100%締め付け
 100%锁紧

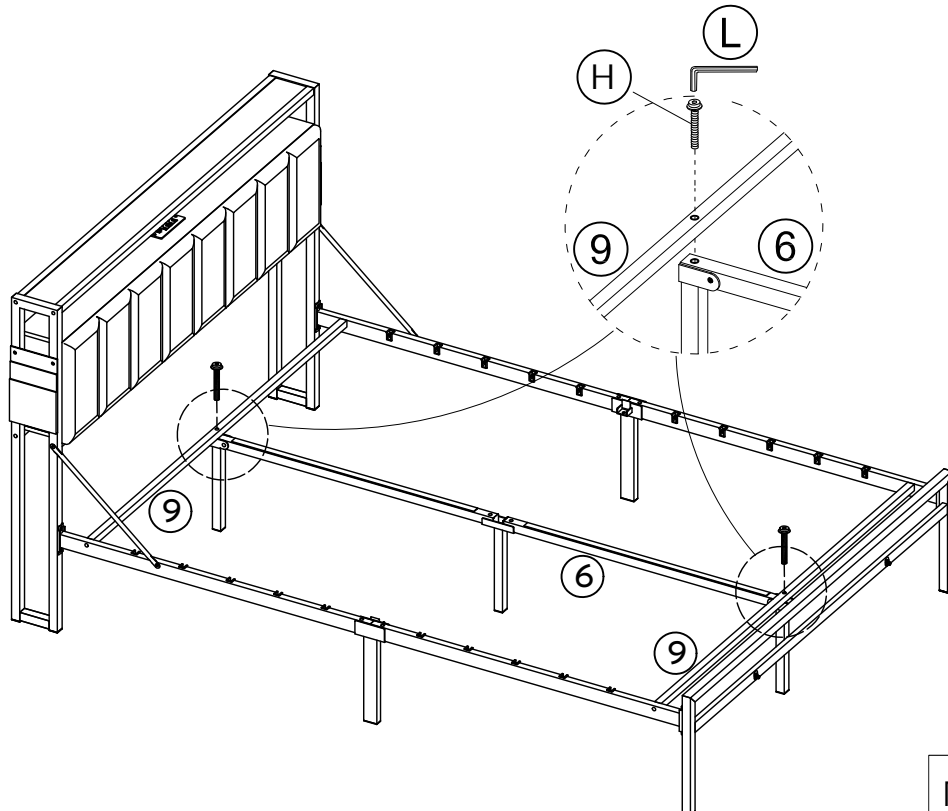

M8*60		(H) X2
		(L) X1

27

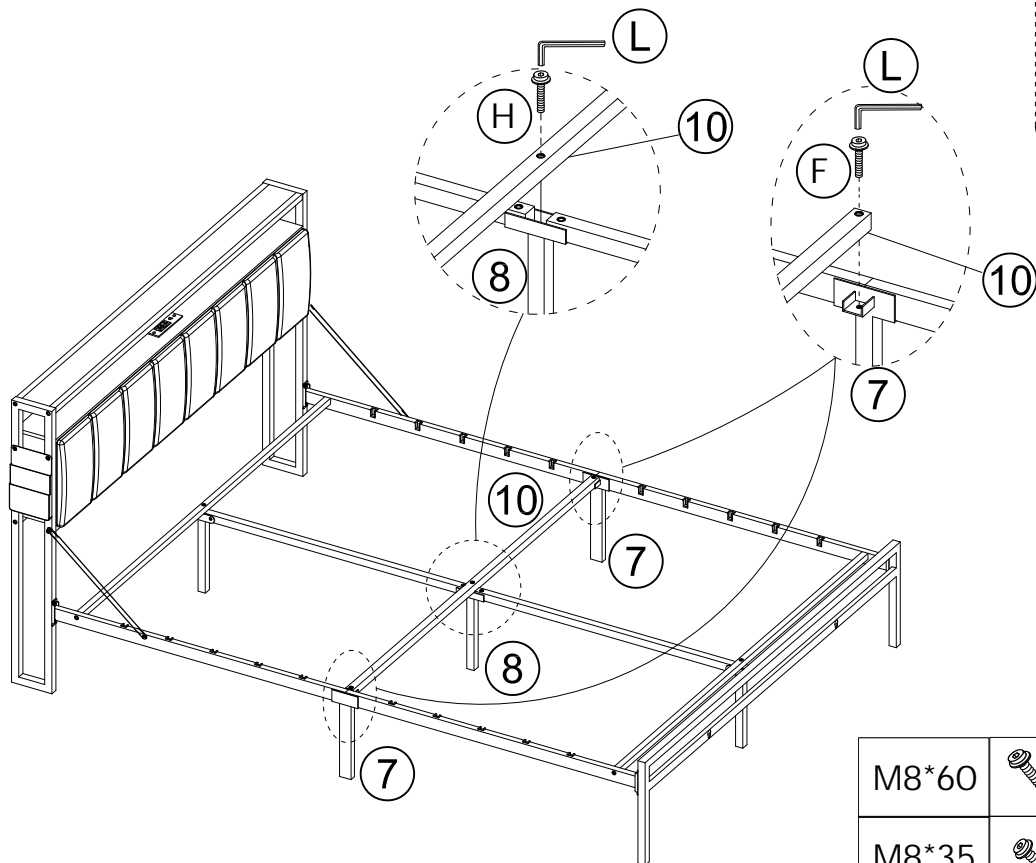

100% tighten
 100% serré
 100% festziehen
 Serraggio al 100%
 100% reforzado
 100%締め付け
 100%锁紧

M8*60		(H) X1
M8*35		(F) X2
		(L) X1

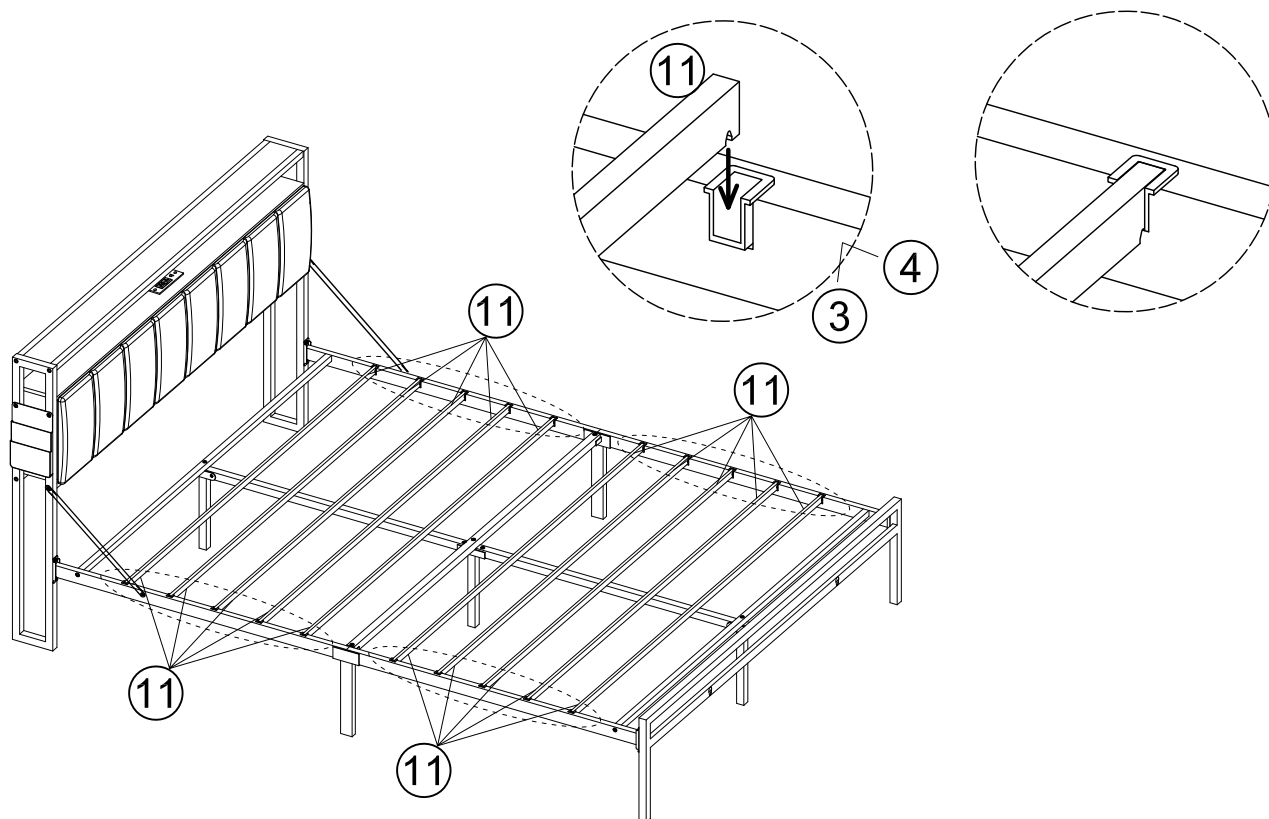

28

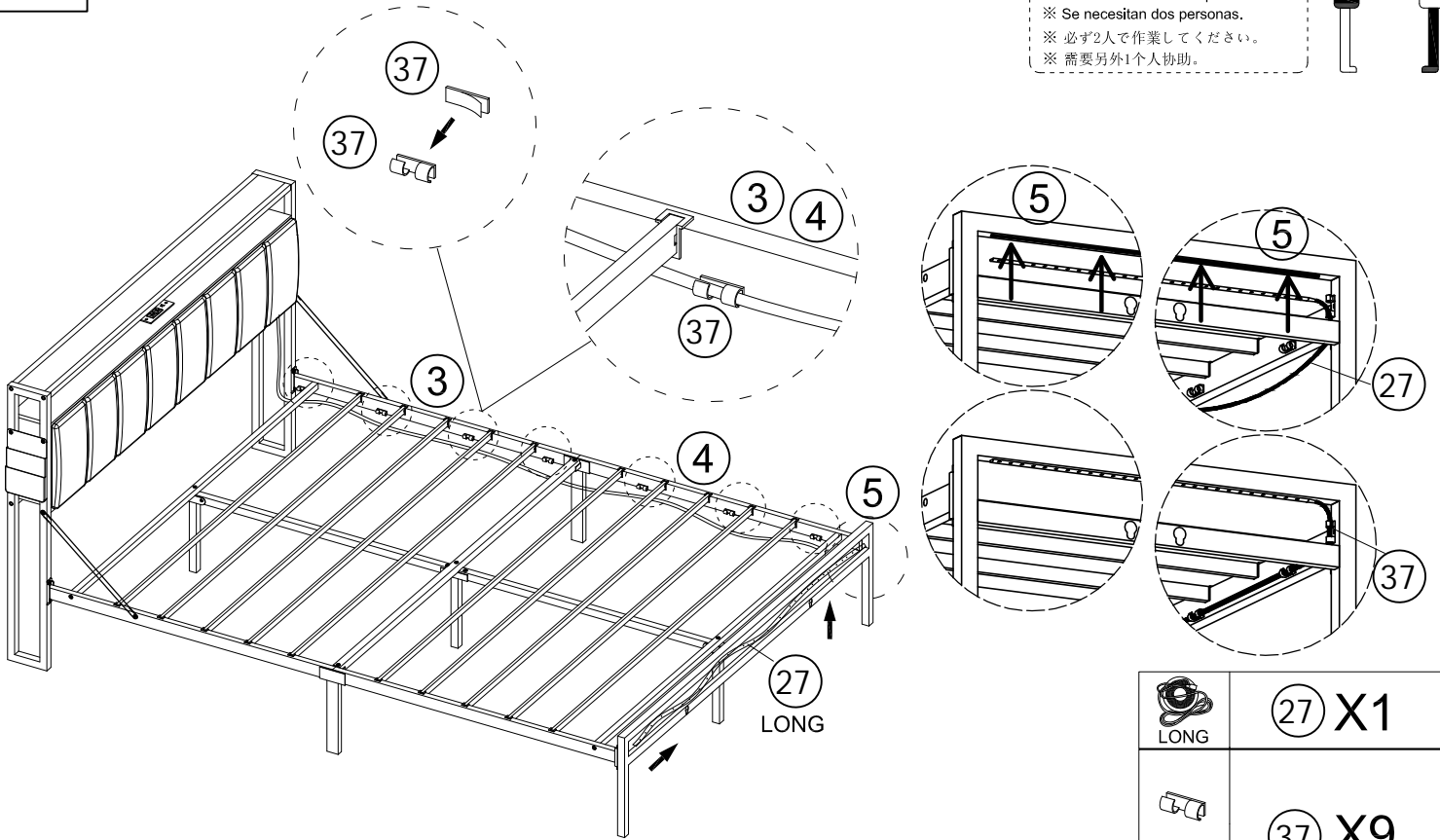
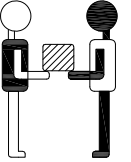

29

※ Two persons are needed.
 ※ Deux personnes sont nécessaires.
 ※ Zwei Personen sind erforderlich.
 ※ Sono necessarie due persone.
 ※ Se necesitan dos personas.
 ※ 必ず2人で作業してください。
 ※ 需要另外1个人协助。



 LONG	(27) X1
	(37) X9

30

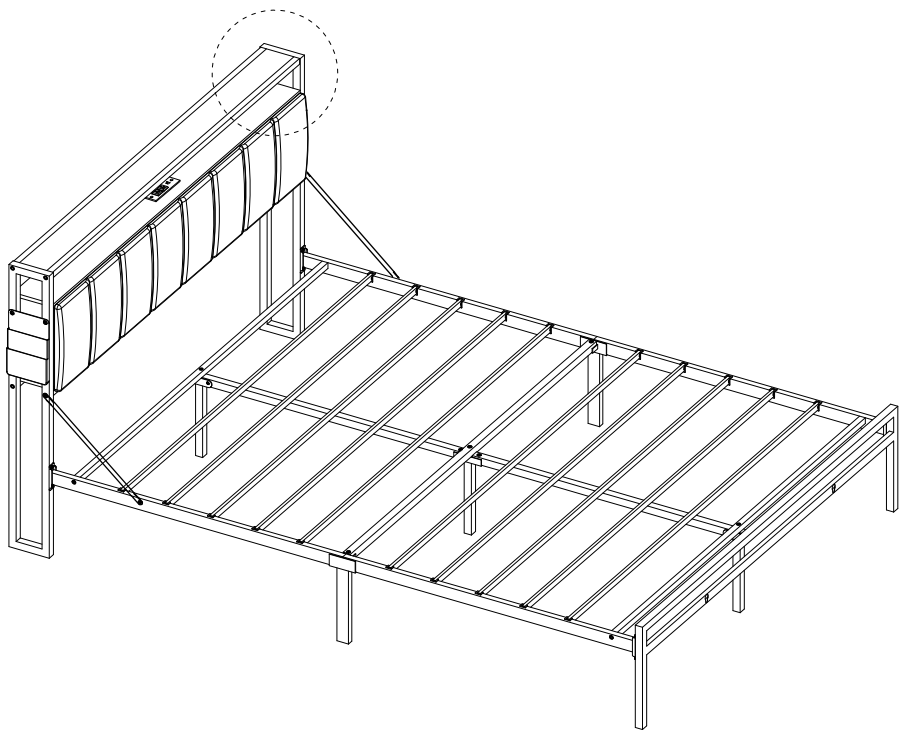
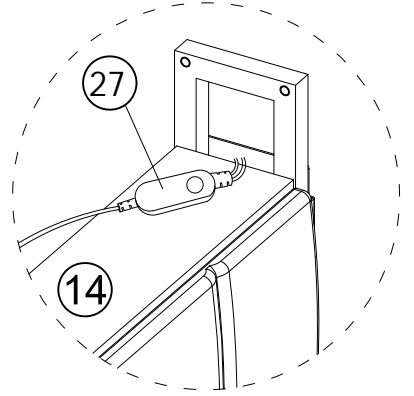

	(27) X1
---	---------

31

Watch the direction

Attention au sens
Achten Sie auf die Richtung
Prestare attenzione alle indicazioni

Mirar la dirección
方向に注意してください
注意方向

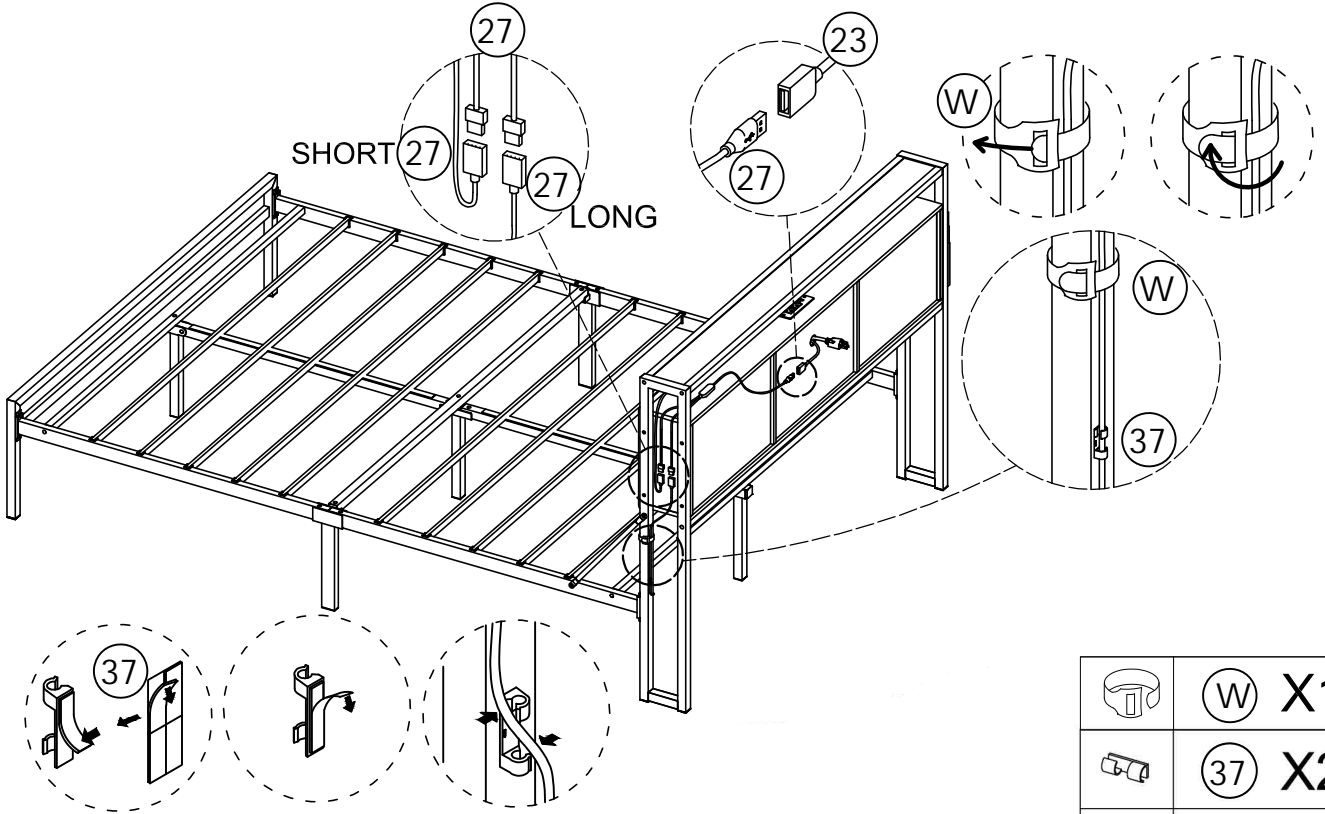

	(W) X1
	(37) X2
	(37) X2

32

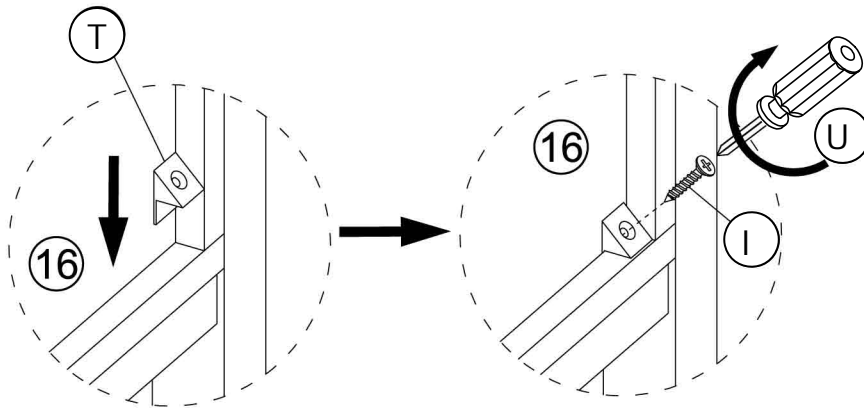

100% tighten
100% serré
100% festziehen
Serraggio al 100%
100% reforzado
100% 締め付け
100% 锁紧

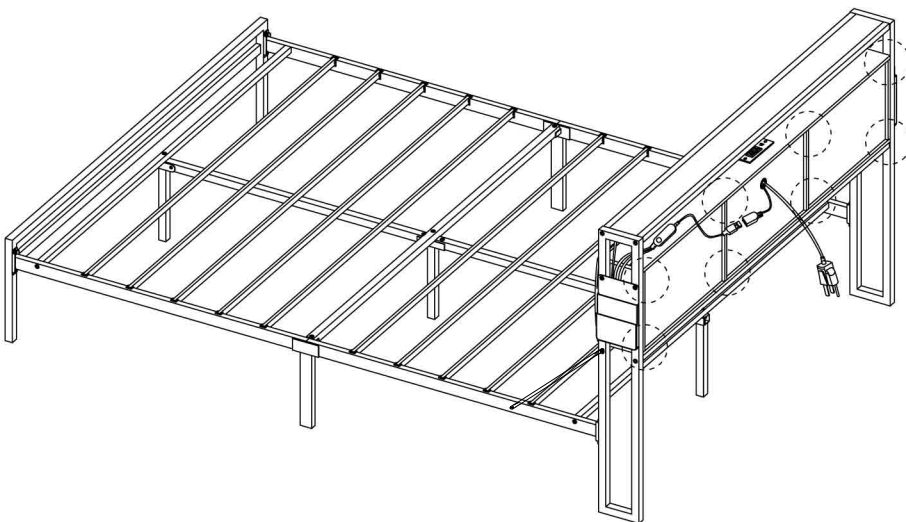

	(U) X1
	(T) X8
3*12	(I) X8

33

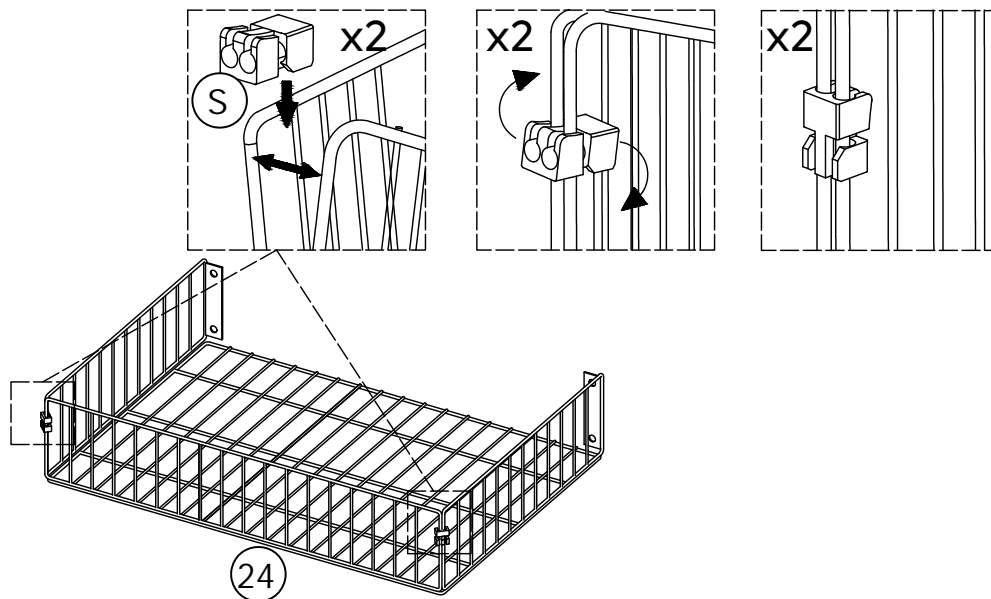

x2



34

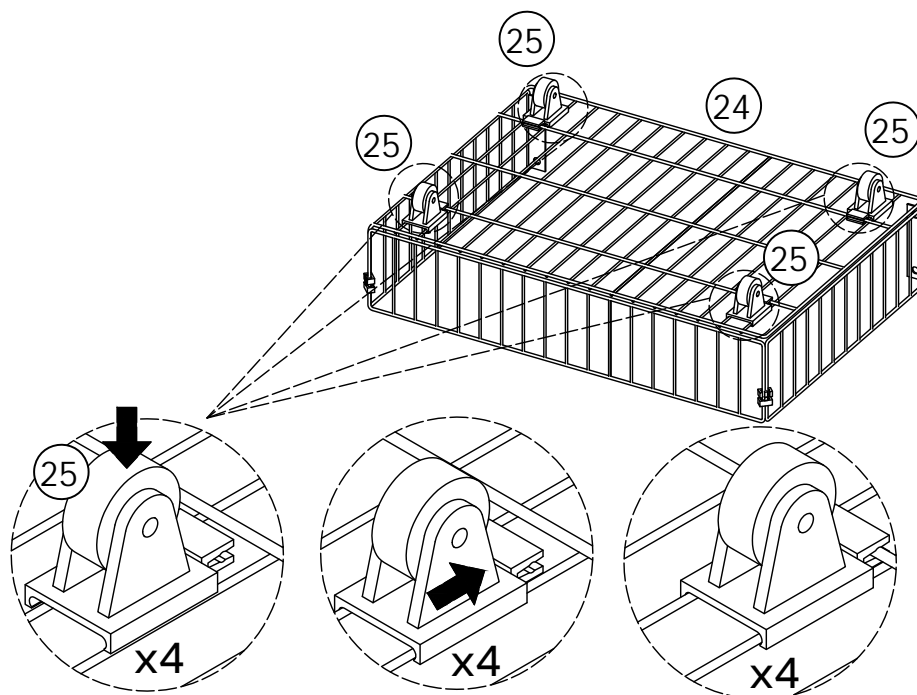

x2

35

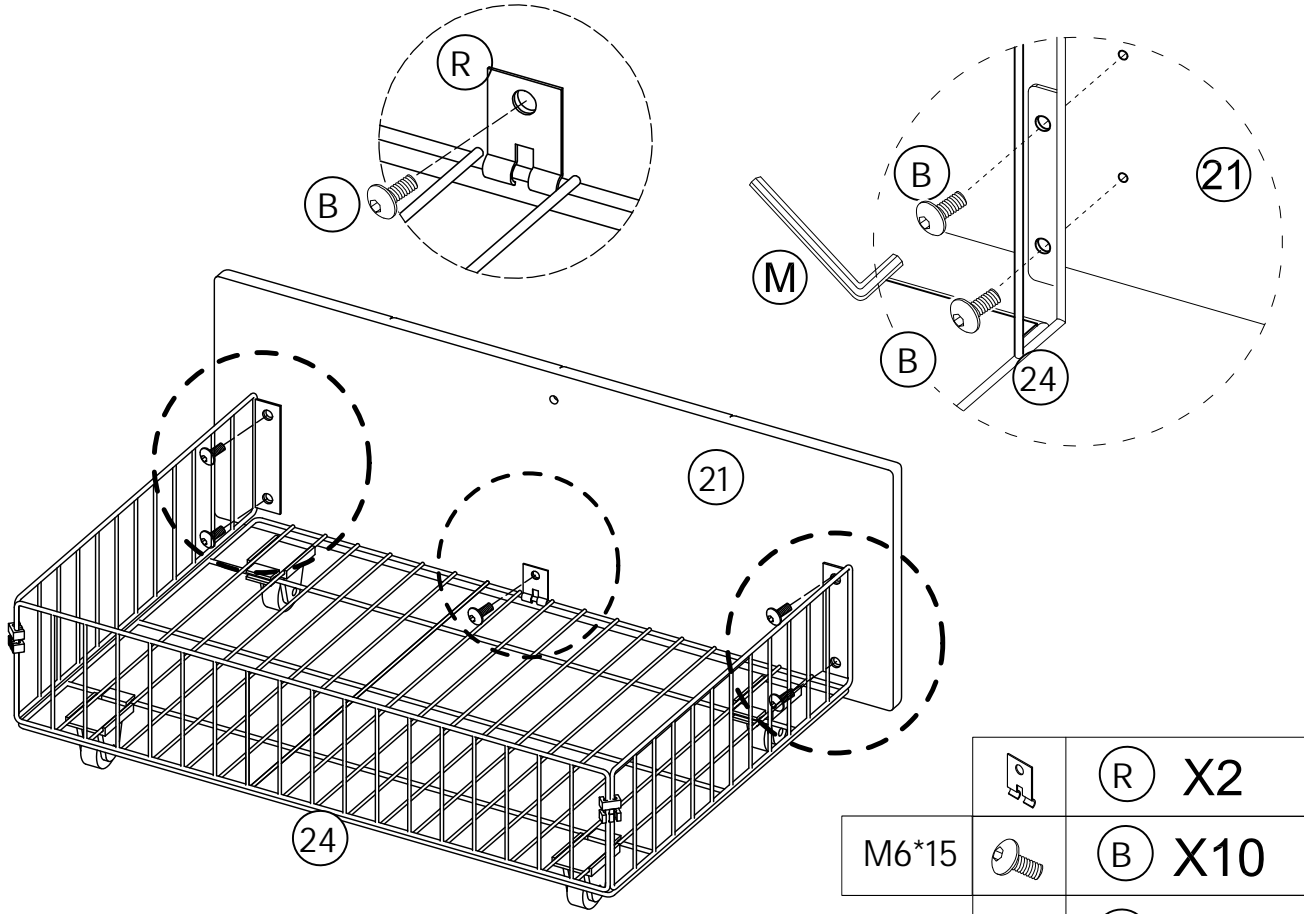

X2

		(R) X2
M6*15		(B) X10
		(M) X1

36

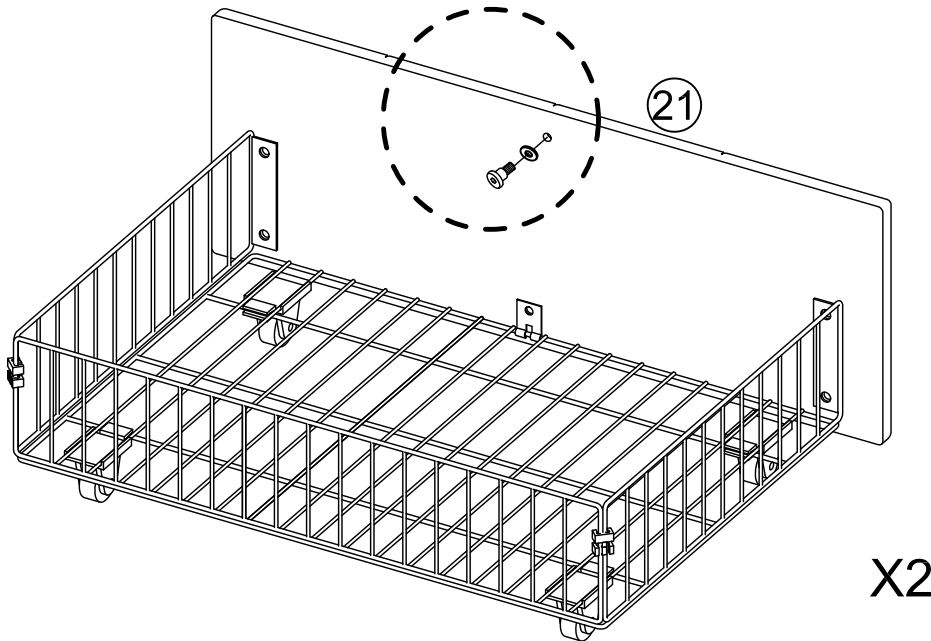

X2

100% tighten
 100% serré
 100% festziehen
 Serraggio al 100%
 100% reforzado
 100%締め付け
 100%锁紧

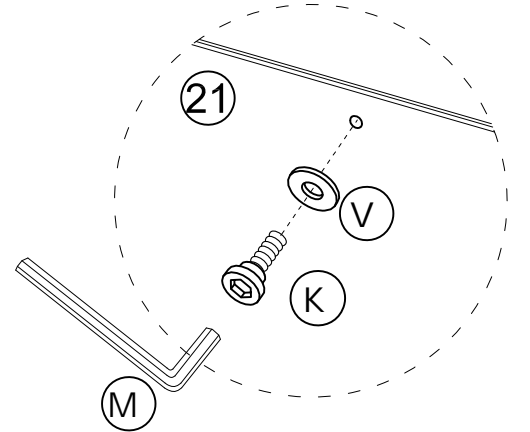

		(V) X2
		(M) X1
M6*20		(K) X2

37

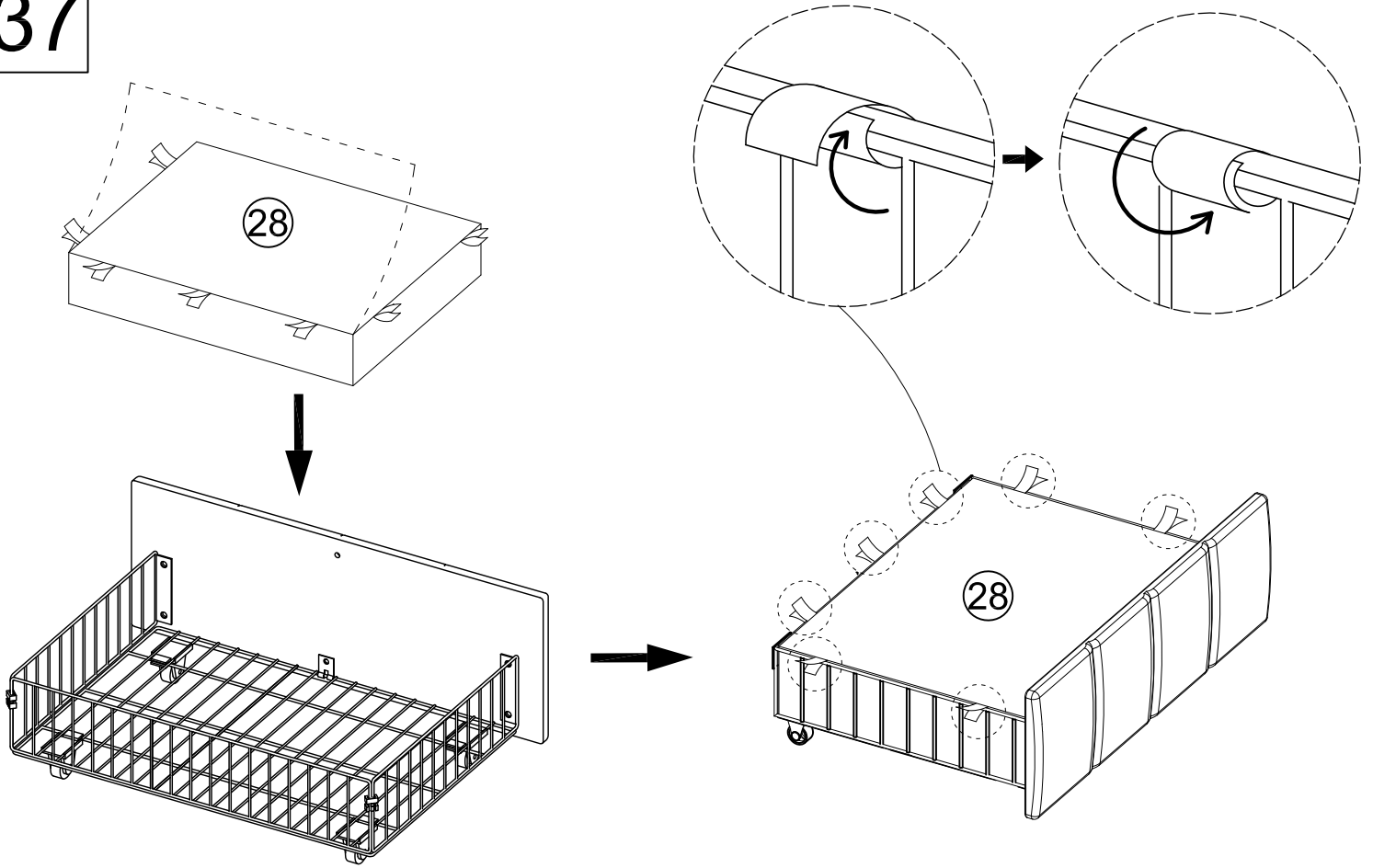

38

