

ASSEMBLY INSTRUCTIONS



**TV
CONSOLE**

ASSEMBLY INSTRUCTIONS

ASSEMBLY TIPS:

1. Remove hardware from box and sort by size.
2. Please check to see that all hardware and parts are present prior to start of assembly.
3. Please follow attached instructions in the same sequence as numbered to assure fast & easy assembly.



WARNING!

1. Don't attempt to repair or modify parts that are broken or defective. Please contact the store immediately.
2. This product is for home use only and not intended for commercial establishments.



ASSEMBLY TIME

60 MINUTES

MAX TV SIZE : 65"

PARTS IDENTIFICATION

A	LEFT SIDE PANEL		1 PC	H	UPPER BACK PANEL		1 PC
B	RIGHT SIDE PANEL		1 PC	I	LOWER BACK PANEL		1 PC
C	UPPER DIVIDER PANEL		1 PC	J	LEFT DRAWER SIDE PANEL		3 PCS
D	LOWER DIVIDER PANEL		2 PCS	K	RIGHT DRAWER SIDE PANEL		3 PCS
E	BOTTOM PANEL		1 PC	L	DRAWER BACK PANEL		3 PCS
F	SHELF		1 PC	M	LEFT DRAWER FRONT PANEL		1 PC
G	TOP PANEL		1 PC	N	RIGHT DRAWER FRONT PANEL		1 PC

NOTE:

Phillips head screw driver is required in the assembly process; however, manufacturer does not provide this item.

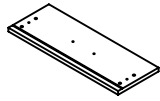

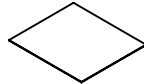



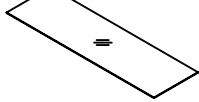



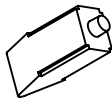

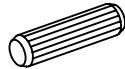
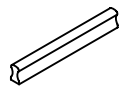
O MIDDLE DRAWER FRONT PANEL  1 PC

P DRAWER BOTTOM PANEL  3 PCS

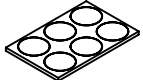
Q CROSS BRACE  1 PC

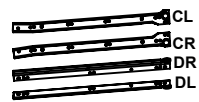
R GLASS  1 PC

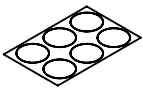
HARDWARE IDENTIFICATION

Z							
NO	DESCRIPTION	FIGURE	Q'TY	NO	DESCRIPTION	FIGURE	Q'TY
1	GLUE 40g		1 PC	8	SCREW Ø 4.3x35mm		12 PCS
2	WOODEN DOWEL Ø 8x30mm		42 PCS	9	HANDLE L=120mm		3 PCS
3	CAM LOCK Ø 15x12mm		24 PCS	10	BOLT Ø 4x28mm		6 PCS
4	CAM BOLT Ø 7x35.5mm		24 PCS	11	FILLING PIECE Ø 12mmx 6 HOLE		1 PC
5	SCREW Ø 3x10mm		42 PCS	12	RAIL L = 400mm		3 SET
6	SCREW Ø 4.5x42mm		6 PCS	13	STICKER Ø 20mm		4 PCS
7	PLASTIC FEET Ø 15mm		5 PCS	14	RUBBER Ø 52mm		2 PCS

Z9,Z10,Z12,Z14 not included in blister packaging.

NOTE:

Phillips head screw driver is required in the assembly process; however, manufacturer does not provide this item.

STEP 1

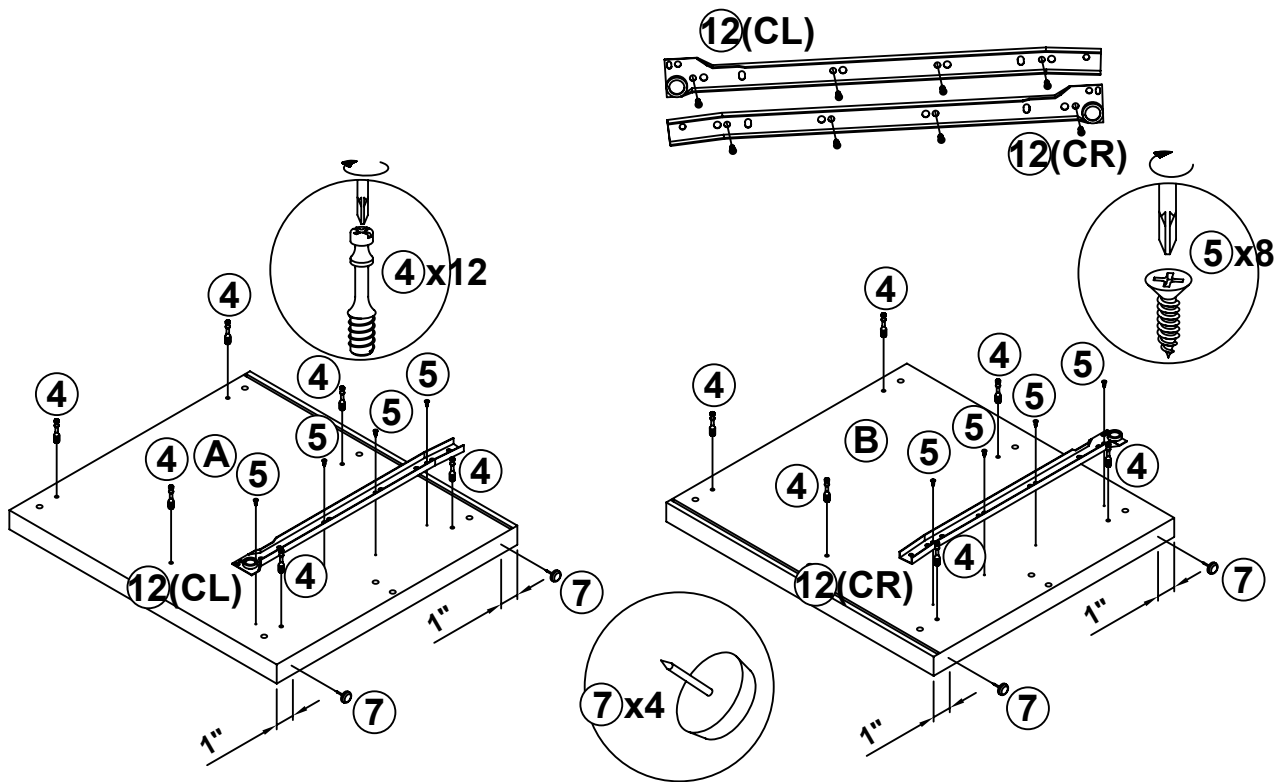

STEP 2

The Glue (1) should be used in the indicated locations to help solidify the assembled unit.

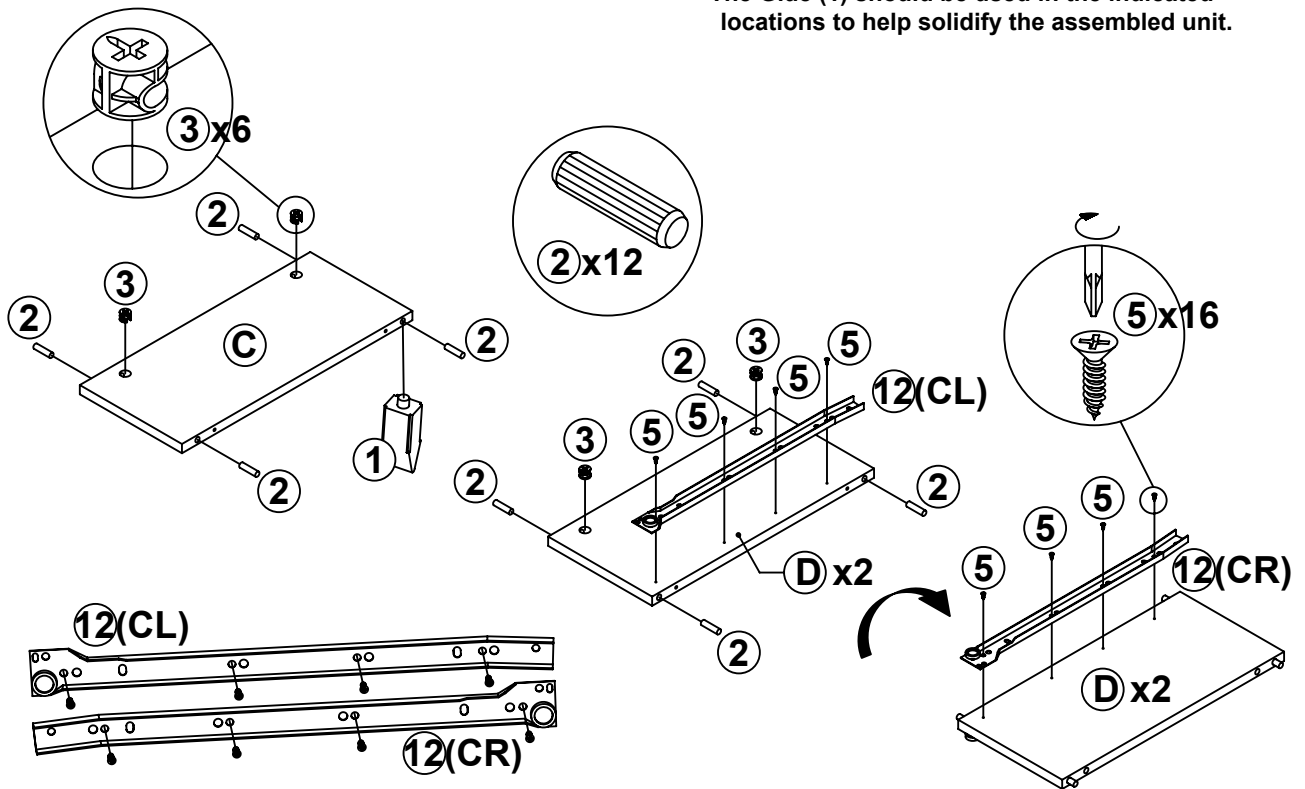

STEP 3

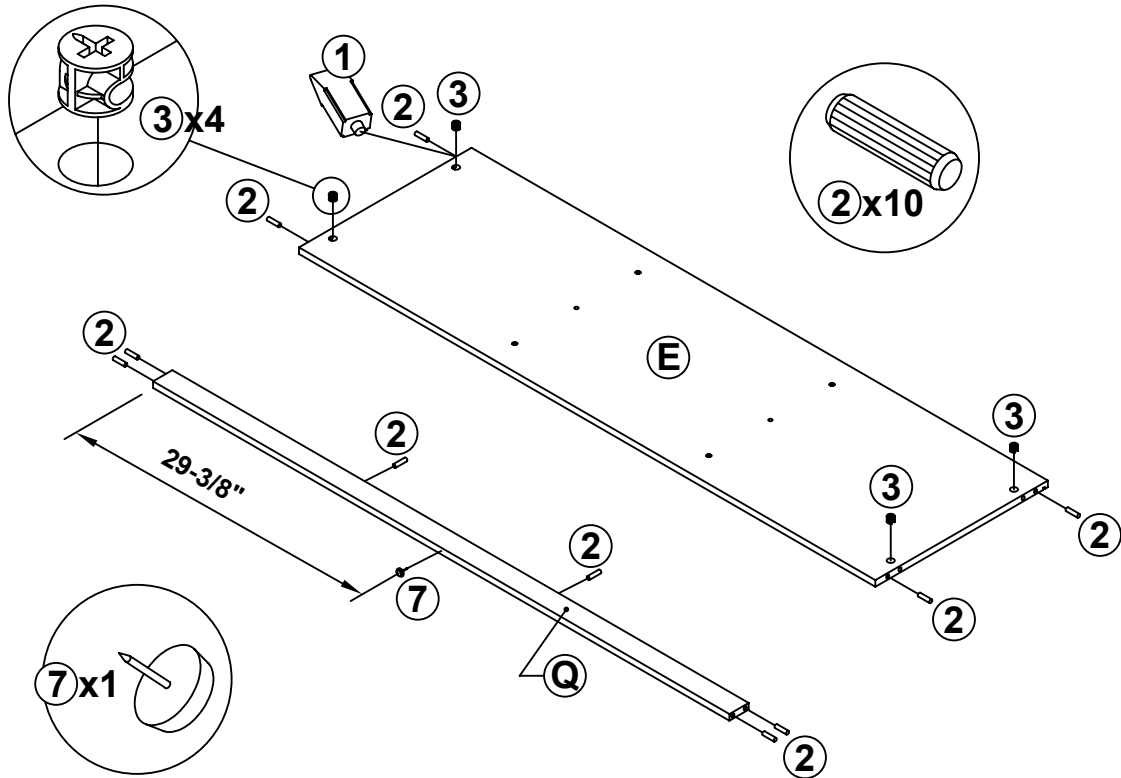

STEP 4

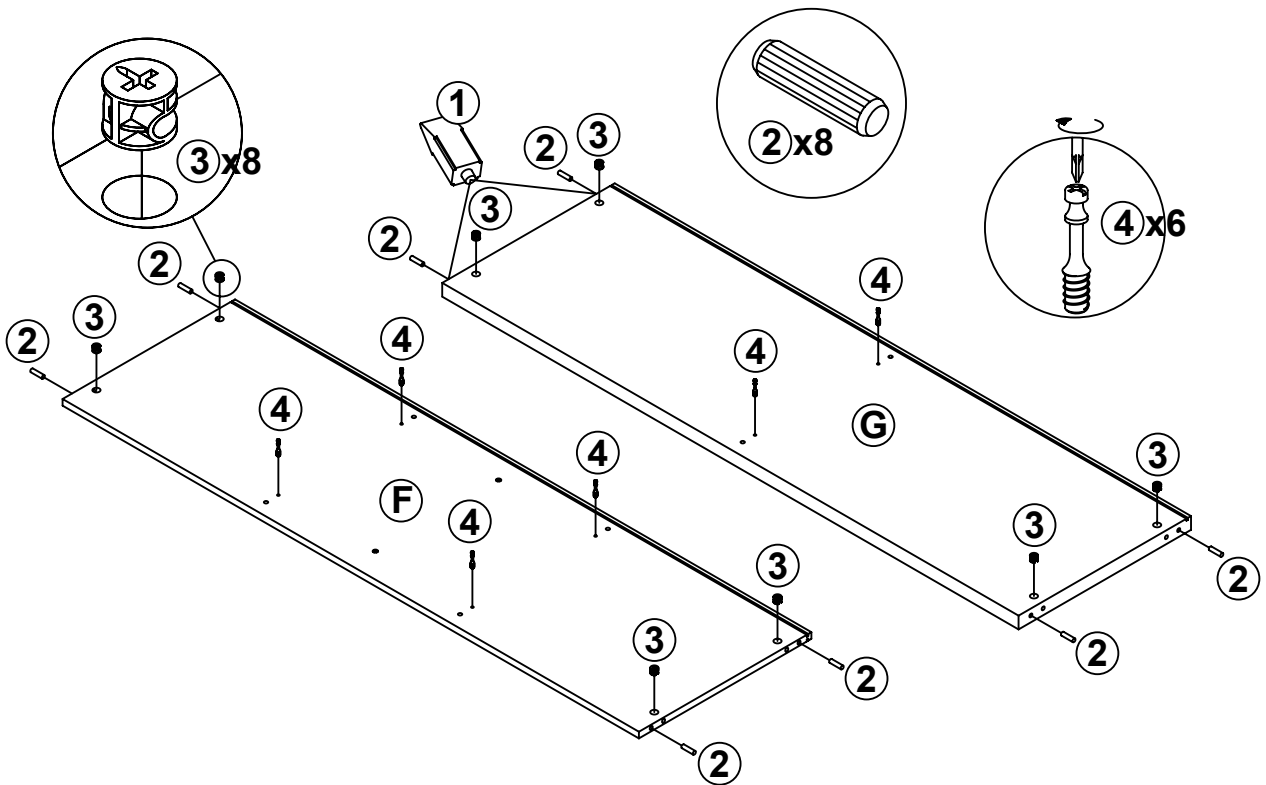

STEP 5

The Glue (1) should be used in the indicated locations to help solidify the assembled unit.

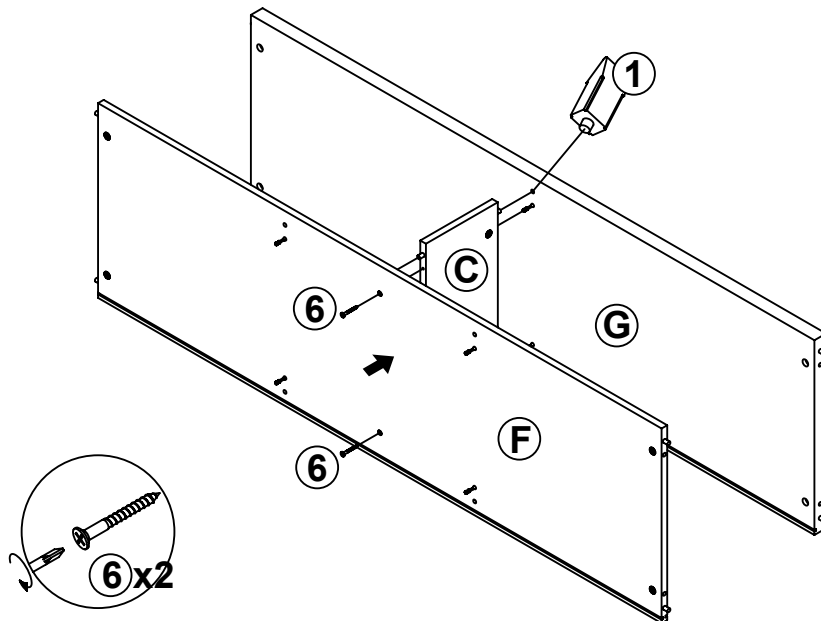

STEP 6

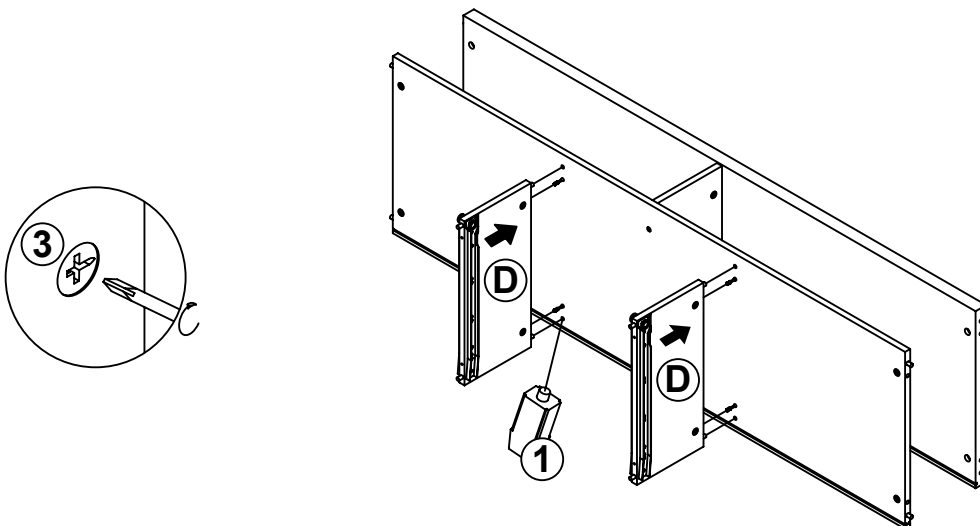

STEP 7

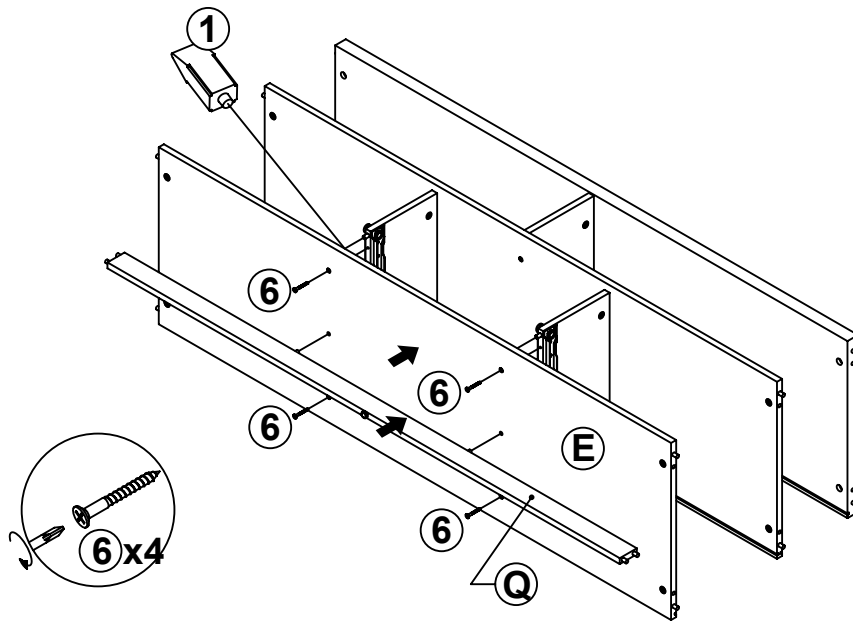

STEP 8

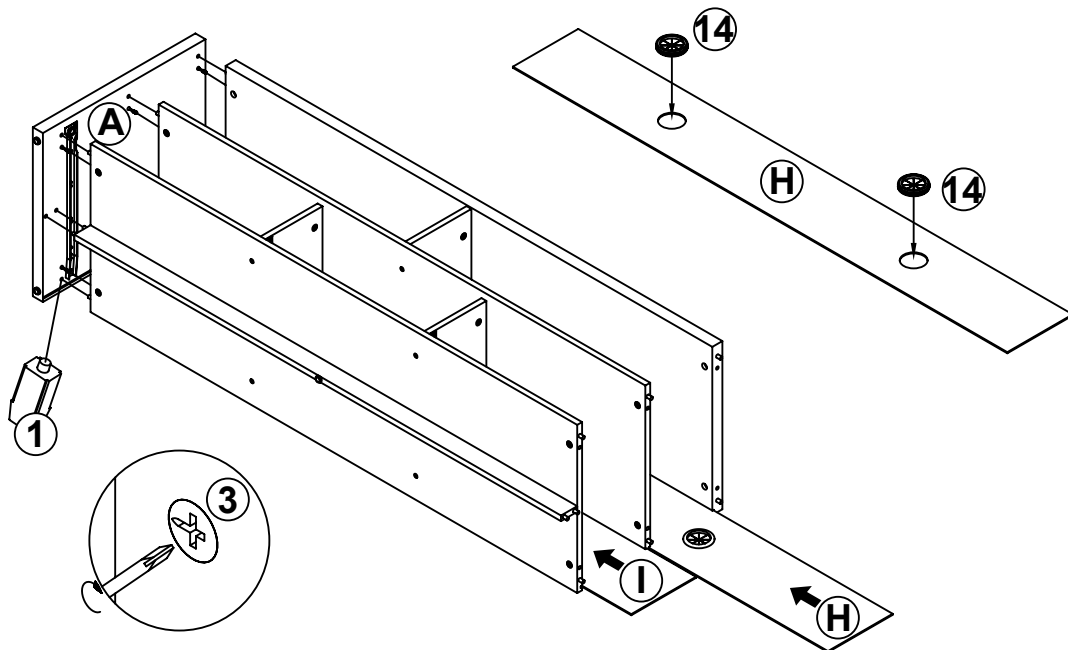

STEP 9

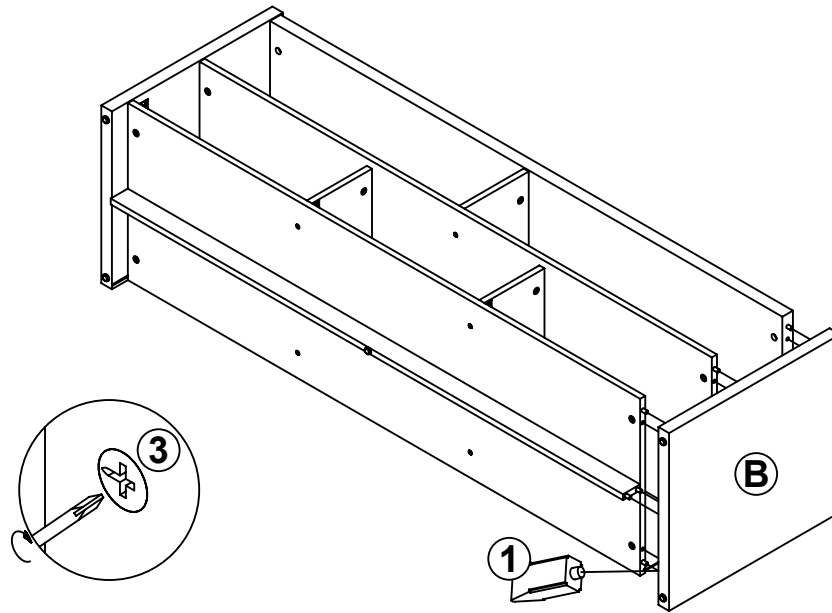

STEP 10

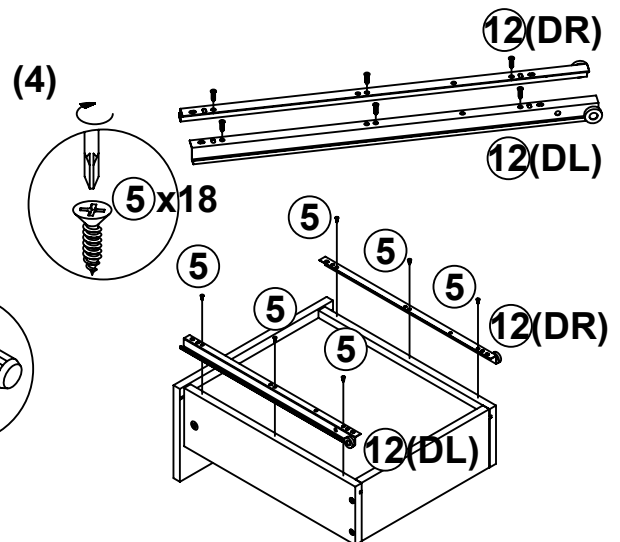
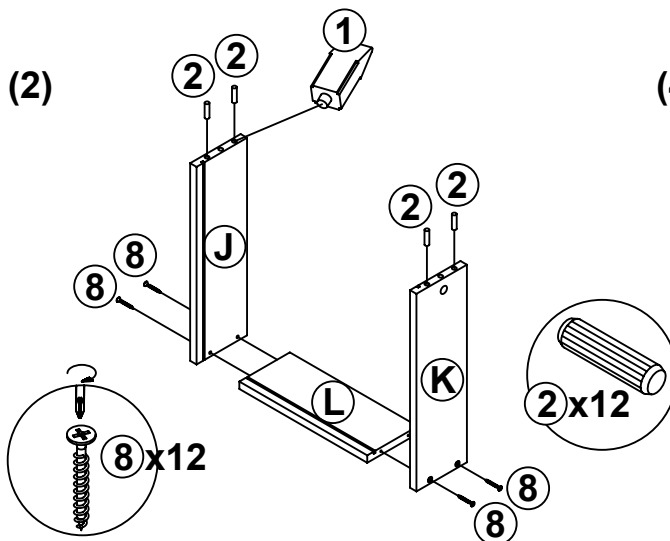
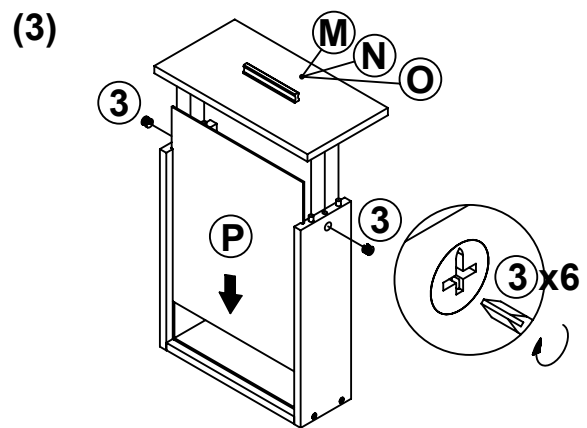
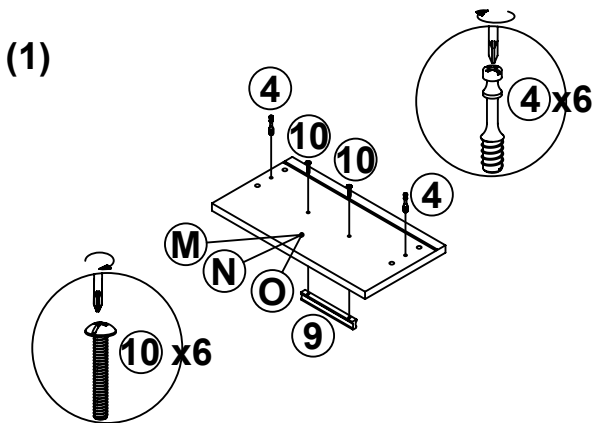

STEP 11

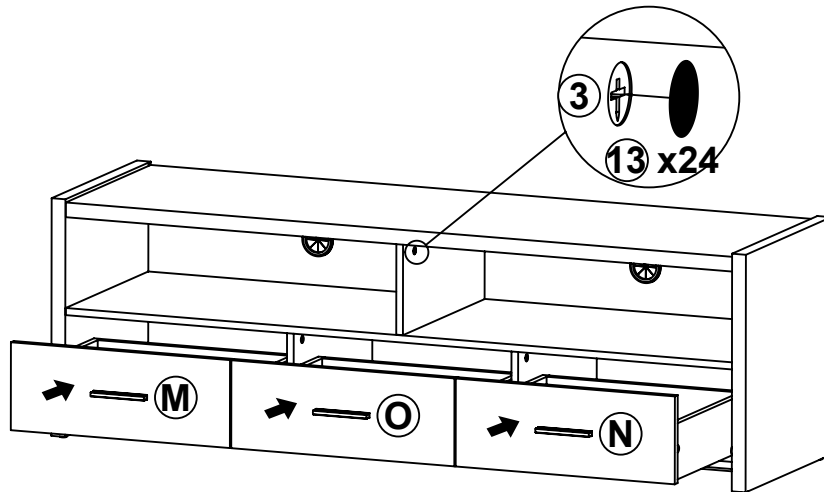

STEP 12

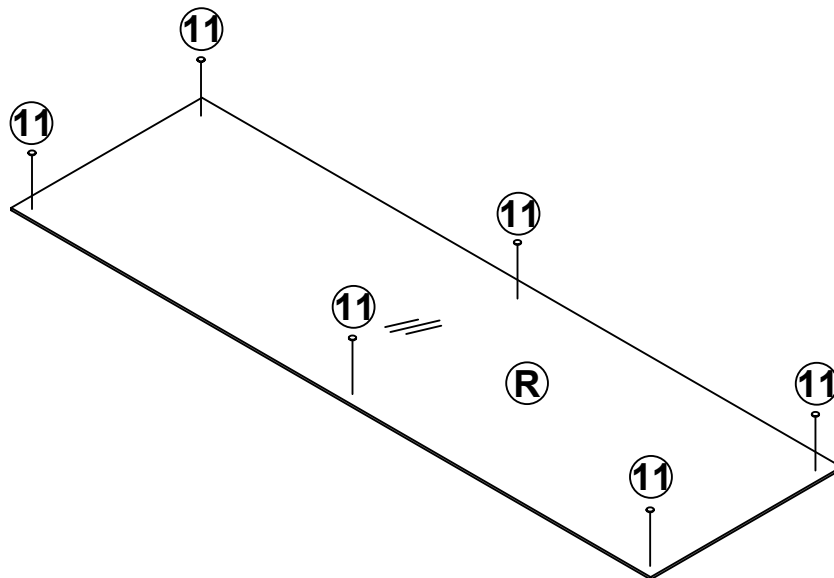

STEP 13 COMPLETE

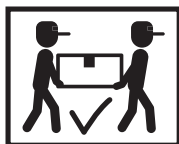
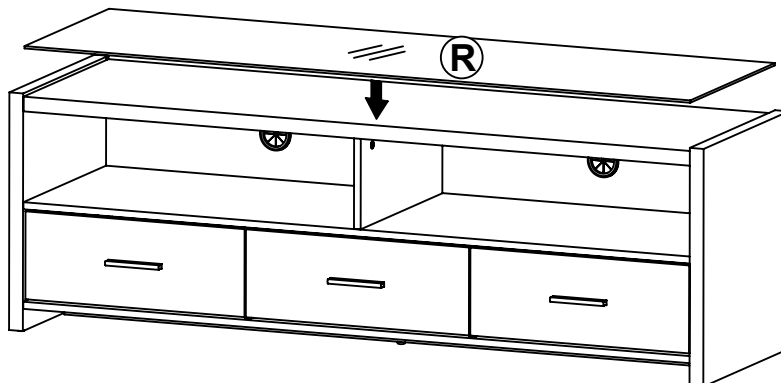

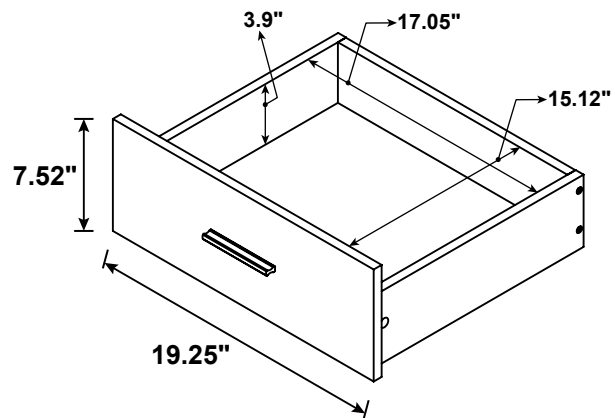
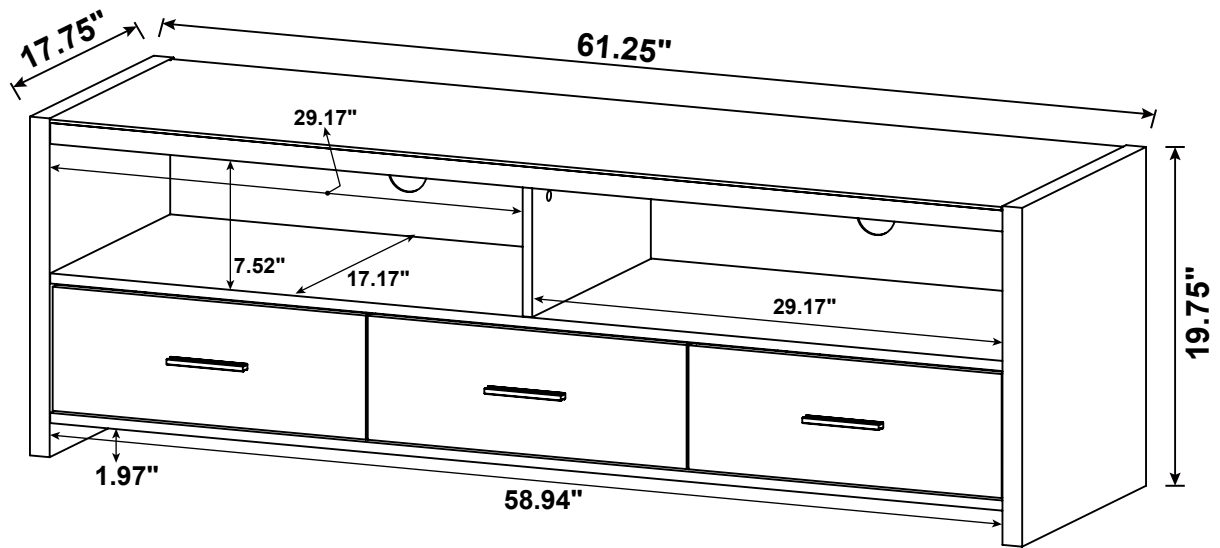

Note : Dimension tolerance $\pm 5\%$