

SKU NUMBER: CM2903 (2024A)-PO#2307120

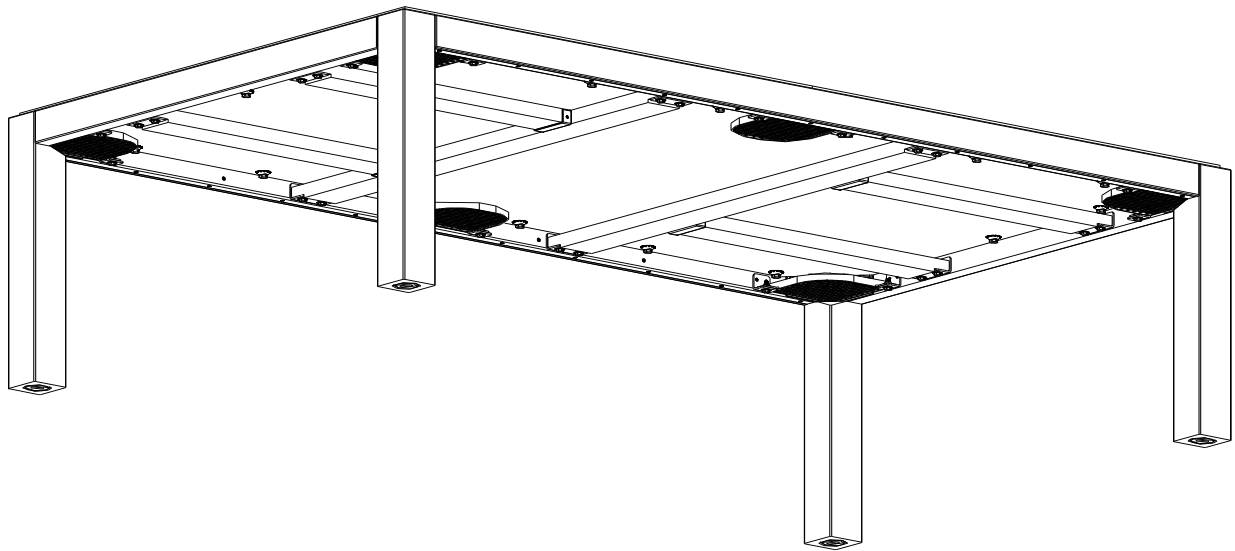

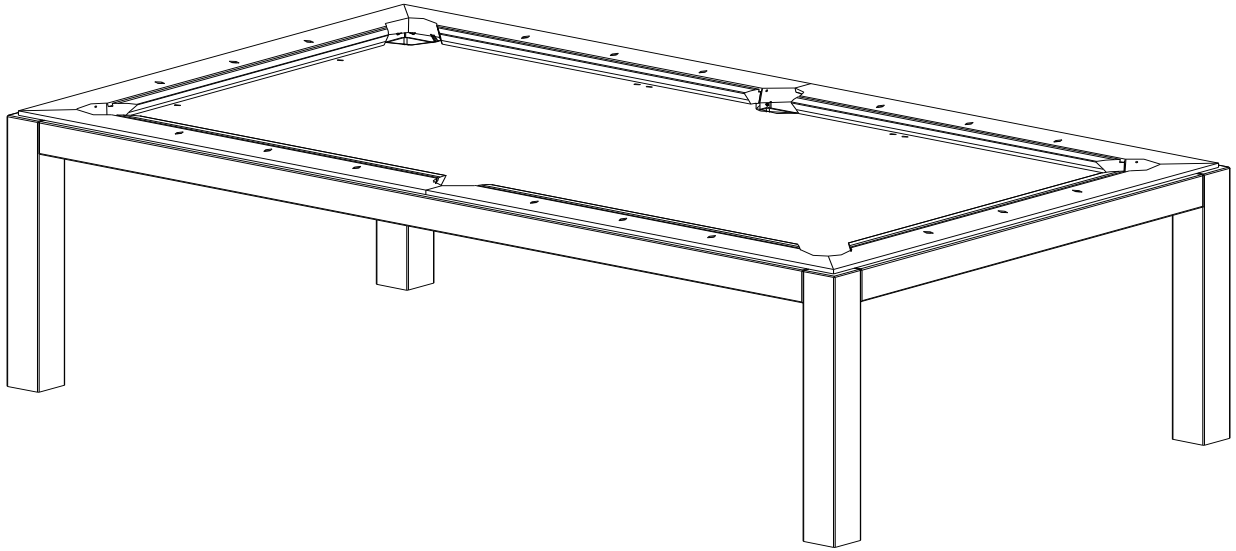

SLATE POOL TABLE



WARNING: Do not attempt to assemble the pool table if any parts are missing or damaged. Improper assembly may lead to damage or serious injury! We strongly recommend using Yelp or Google to [locate local billiard stores](#) with professionals experienced in assembling pool tables instead of relying on the provided "professional" general furniture assembly service ([For example of Angi](#)). Slate leveling and attaching the felt require expertise beyond typical furniture installation. Regular installations typically require the assistance of two or more adults.

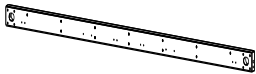
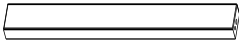

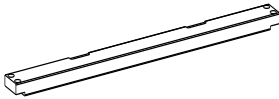
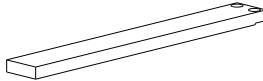
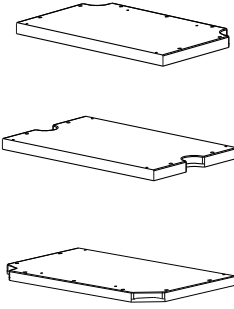
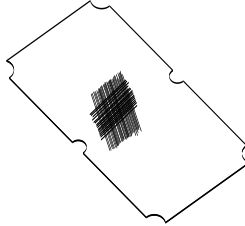

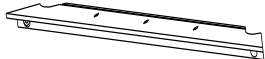







Please read the following instructions carefully prior to assembly. Check the parts list to make sure you have all the parts needed for proper assembly.











PARTS LIST (1)

NO.	IMAGE	DESCRIPTION	SPECIFICATION(mm)	QTY	UNIT
A		LONG FRAME	2402*91*45	2	PCS
		ASSEMBLY POSITION	FRAME		
B		SHORT FRAME	1283*91*45	2	PCS
		ASSEMBLY POSITION	FRAME		
C		TABLE LEG	753*100*100	4	PCS
		ASSEMBLY POSITION	FRAME		
D		CROSS BEAM	1383*98*38	2	PCS
		ASSEMBLY POSITION	FRAME		
E		SIDE BEAM	795*98*38	4	PCS
		ASSEMBLY POSITION	FRAME		
F		SIDE SLATE 1	804*1295*25	1	PCS
		ASSEMBLY POSITION	TOP RAIL		
		MIDDLE SLATE	804*1295*25	1	PCS
		ASSEMBLY POSITION	TOP RAIL		
		SIDE SLATE 2	804*1295*25	1	PCS
		ASSEMBLY POSITION	TOP RAIL		
G		Big Felt for Slate Bed (G1)	2500*1450	1	PCS
		Small Felt for Cushion Rails (G2)	1250*160	6	PCS
		ASSEMBLY POSITION	SLATE BED + TOP RAIL		
H		#2 & #5 TOP SIDE RAIL	1301*163*43	2	PCS
		ASSEMBLY POSITION	TOP RAIL		
I		#3 & #6 TOP SIDE RAIL	1281*163*43	2	PCS
		ASSEMBLY POSITION	TOP RAIL		
J		#1 & #4 TOP END RAIL	1443*163*43	2	PCS
		ASSEMBLY POSITION	TOP RAIL		

PARTS LIST (2)

	NO.	IMAGE	DESCRIPTION	SPECIFICATION(mm)	QTY	UNIT	
Step ①	H1		ANGLE BAR FOR NET BAG	50*34*45	12	PCS	
			FOR POCKET				ASSEMBLY POSITION
	H2		ANGLE BAR FOR BEAM	100*45*45	8	PCS	
			FOR CROSS BEAM				ASSEMBLY POSITION
①	H3		FLAT HEAD SCREW	4.2*30	40	PCS	
			FOR ANGLE				ASSEMBLY POSITION
Step ②	H4		NUT	M10	8	PCS	
			FOR TABLE LEG AND FRAME				ASSEMBLY POSITION
	H5		FLAT WASHER	M10*30*2	8	PCS	
			FOR TABLE LEG AND FRAME				ASSEMBLY POSITION
	H6		BLACK SEMICIRCLE	M10	8	PCS	
			FOR TABLE LEG AND FRAME				ASSEMBLY POSITION
	②	H7		DOUBLE HEAD SCREW	ø10*100	8	PCS
				FOR TABLE LEG AND FRAME			
	H8		CYLINDRICAL NUT	ø10*20	8	PCS	
FOR TABLE LEG AND FRAME				ASSEMBLY POSITION			
H9		WOODEN PLUG	ø12*60	8	PCS		
		FOR TABLE LEG AND FRAME				ASSEMBLY POSITION	
Step ③	H10		ANGLE BAR FOR FRAME	150*150*88	4	PCS	
			FOR TABLE LEG AND FRAME				ASSEMBLY POSITION
③	H3		FLAT HEAD SCREW	4.2*30	56	PCS	
			FOR TABLE LEG AND FRAME				ASSEMBLY POSITION
Step ④	H11		CROSS BEAM SUPPORT	107*48*41	4	PCS	
			FOR CROSS BEAM				ASSEMBLY POSITION
④	H3		FLAT HEAD SCREW	4.2*30	12	PCS	
			FOR CROSS BEAM				ASSEMBLY POSITION
Step ⑤	H12		HEX BOLT	ø8*40	8	PCS	
			FOR CROSS BEAM AND TABLE FRAME				ASSEMBLY POSITION
	H13		FLAT WASHER	M8*25*1	16	PCS	
⑤	H14		NUT	M8	8	PCS	
			FOR CROSS BEAM AND TABLE FRAME				ASSEMBLY POSITION

Step ⑥	H12		HEX BOLT	ø8*40	8	PCS
			FOR SIDE BEAM AND TABLE FRAME			
	H13		FLAT WASHER	M8*25*1	16	PCS
			FOR SIDE BEAM AND TABLE FRAME			
H14		NUT	M8	8	PCS	
		FOR SIDE BEAM AND TABLE FRAME				ASSEMBLY POSITION
H3		FLAT HEAD SCREW	4.2*30	8	PCS	
		FOR SIDE BEAM AND TABLE FRAME				ASSEMBLY POSITION
Step ⑦	H19		WOODEN SCREW	5*50	12	PCS
			FOR SLATE AND TABLE FRAME			
Step ⑨	H15		CORNER POCKET PLATE	/	4	PCS
			FOR TBLE FRAME			
	H16		SIDE POCKET PLATE	/	2	PCS
			FOR TBLE FRAME			
	H17		HEX BOLT	ø8*25	12	PCS
			FOR CROSS BEAM AND TABLE FRAME			
	H18		FLAT WASHER	M8*20*1	24	PCS
			PLEASE SEE THE INSTALLATION SHEET			
	H29		SPRING WASHER	M8	12	PCS
			PLEASE SEE THE INSTALLATION SHEET			
H14		NUT	M8	12	PCS	
		PLEASE SEE THE INSTALLATION SHEET				ASSEMBLY POSITION
Step ⑩	H20		METAL CONNECTOR	100*30*3	2	PCS
			FOR #2,#5AND #3 ,#6 TOP RAIL			
H21		FLAT HEAD SCREW	4.2*25	8	PCS	
		FOR #2,#5AND #3 ,#6 TOP RAIL				ASSEMBLY POSITION

Step ⑪	H22		HEX BOLT	ø8*50	4	PCS
			FOR #1、#4 AND #2、#3、#5、#6 TOP RAIL			
	H23		WOODEN PLUG	ø12*40	4	PCS
			FOR #1、#4 AND #2、#3、#5、#6 TOP RAIL			
H18		FLAT WASHER	M8*20*1	8	PCS	
		FOR #1、#4 AND #2、#3、#5、#6 TOP RAIL				ASSEMBLY POSITION
H14		NUT	M8	4	PCS	
		FOR #1、#4 AND #2、#3、#5、#6 TOP RAIL				ASSEMBLY POSITION
Step ⑫	H24		HEX BOLT	ø10*60	18	PCS
			FOR THE TOP RAIL AND SLATE			
H25		DOME WASHER	M10*36*5	18	PCS	
		FOR THE TOP RAIL AND SLATE				ASSEMBLY POSITION
Step ⑬	H26		CORNER POCKET	/	4	PCS
H27		SIDE POCKET	/	2	PCS	
						ASSEMBLY POSITION
H28		Stainless Nail	5/64"L=5/8"	12	PCS	
		FOR POCKET				ASSEMBLY POSITION
H30		Poker Playing Card	/	1	BOX	
		BETWEEN BEAMS TO SLATE				ASSEMBLY POSITION
H31		3M super 77 adhesive	/	1	BOTTLE	
		ON THE SLATE AND FELT				ASSEMBLY POSITION

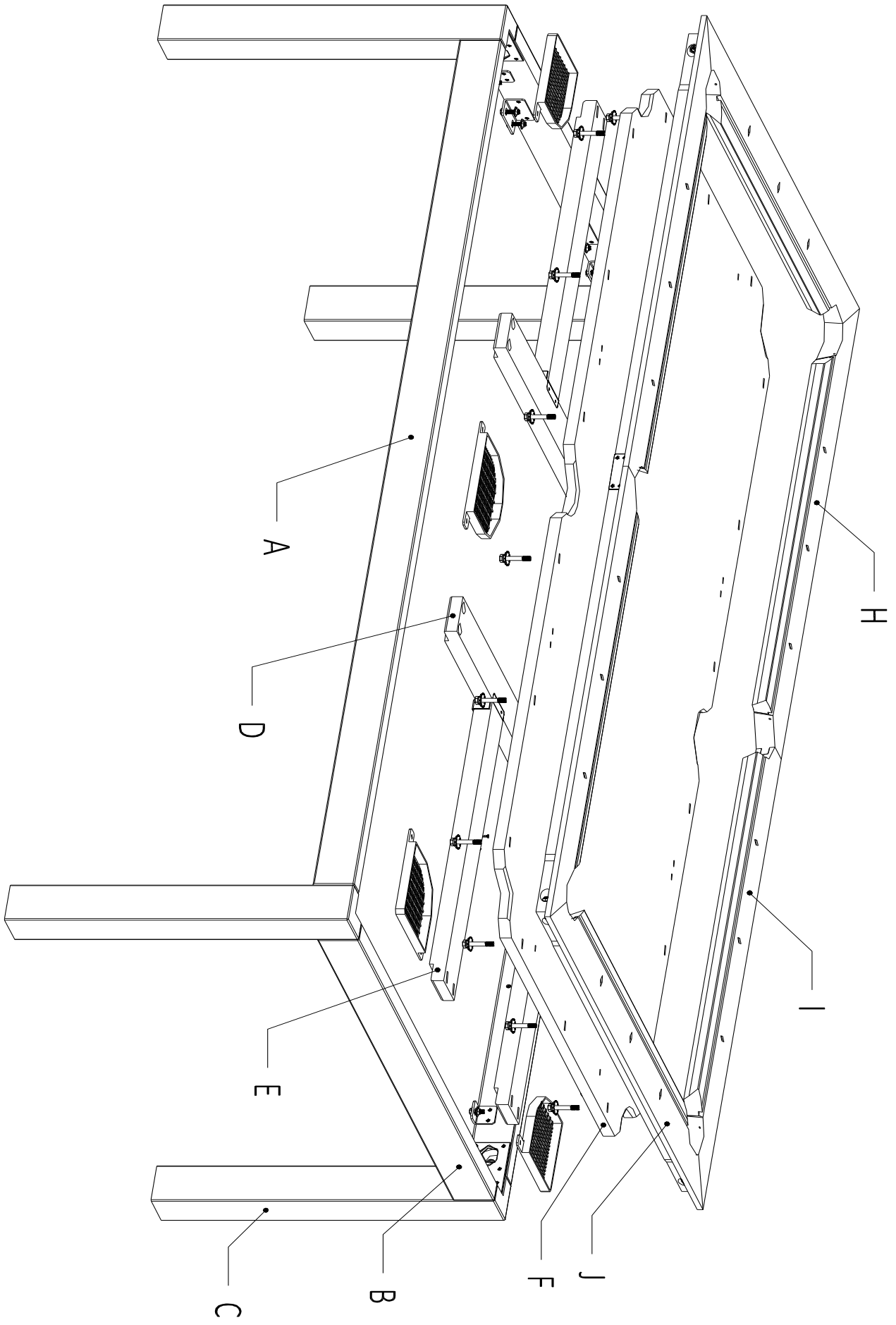

Steps 1

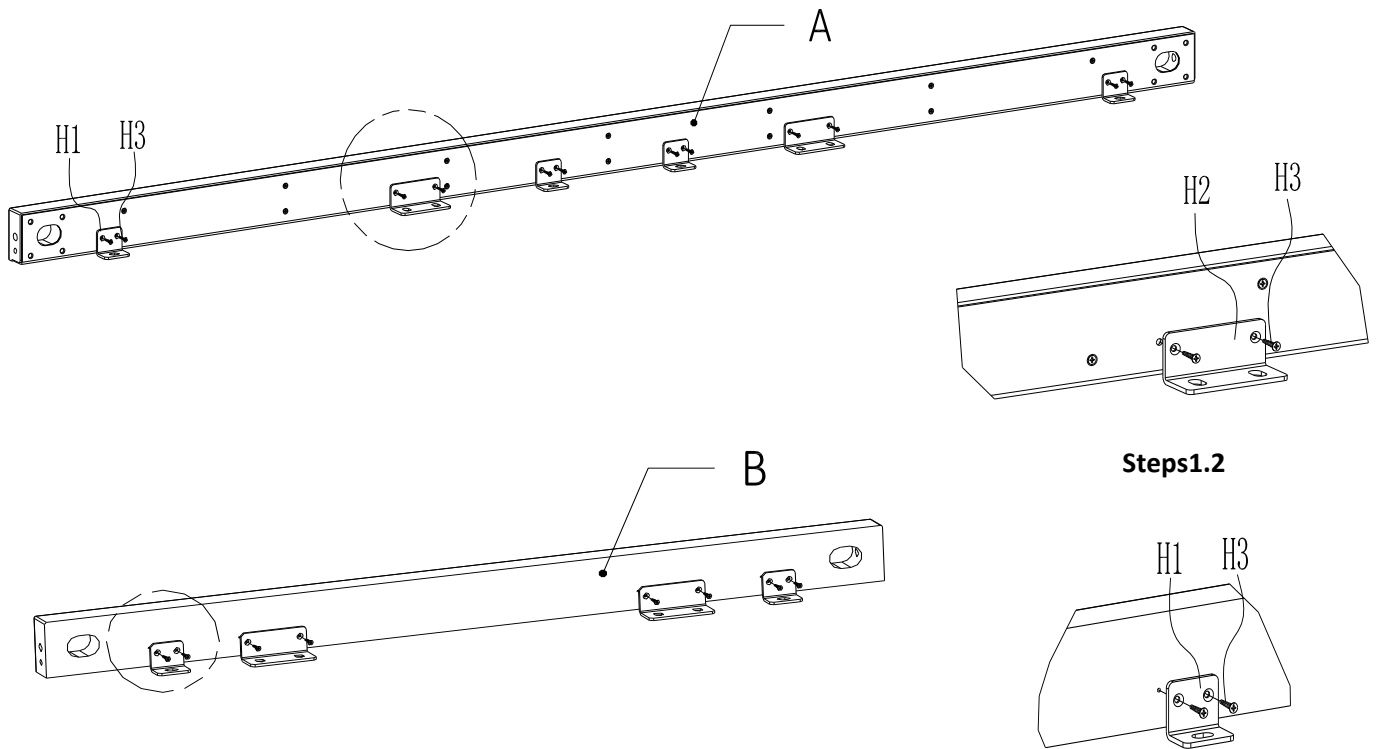

Refer to the provided diagram. Attach angle bars (H1) and (H2) to the long frame (A) and short frame (B) using flat head screws (H3). Make sure the bottom of each angle bar is perfectly aligned with the bottom of the long frame. Locate the pre-marked holes on the frame for accurate alignment. Securely fasten the screws into these pilot holes.

Steps 2

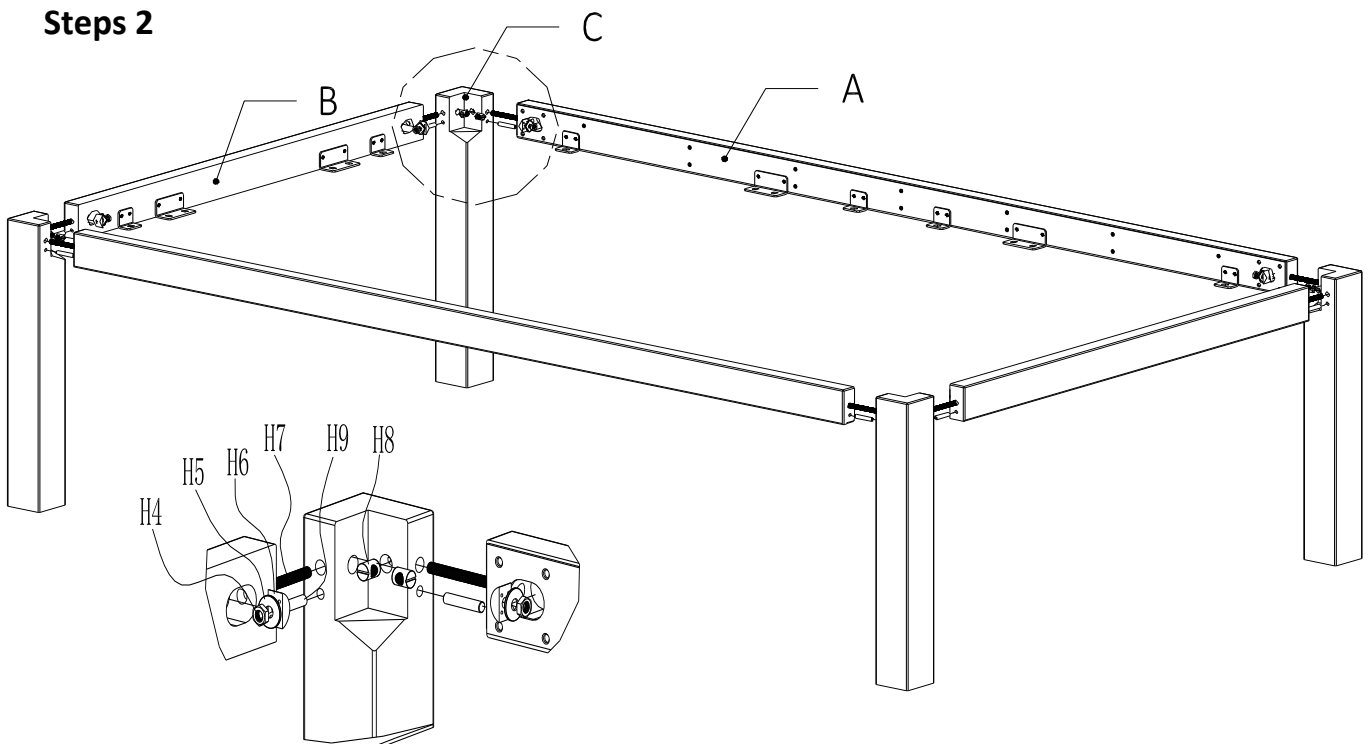

Follow the diagrams to assemble the table. Connect the long frame (A) to the short frame (B) and the table leg (C) using cylindrical nuts (H8), double head screws (H7), black semicircles (H6), flat washers (H5), nuts (H4), and wooden plugs (H9). This process requires at least two people. Start with the short frame (B), then attach the long frame (A).

Steps 3

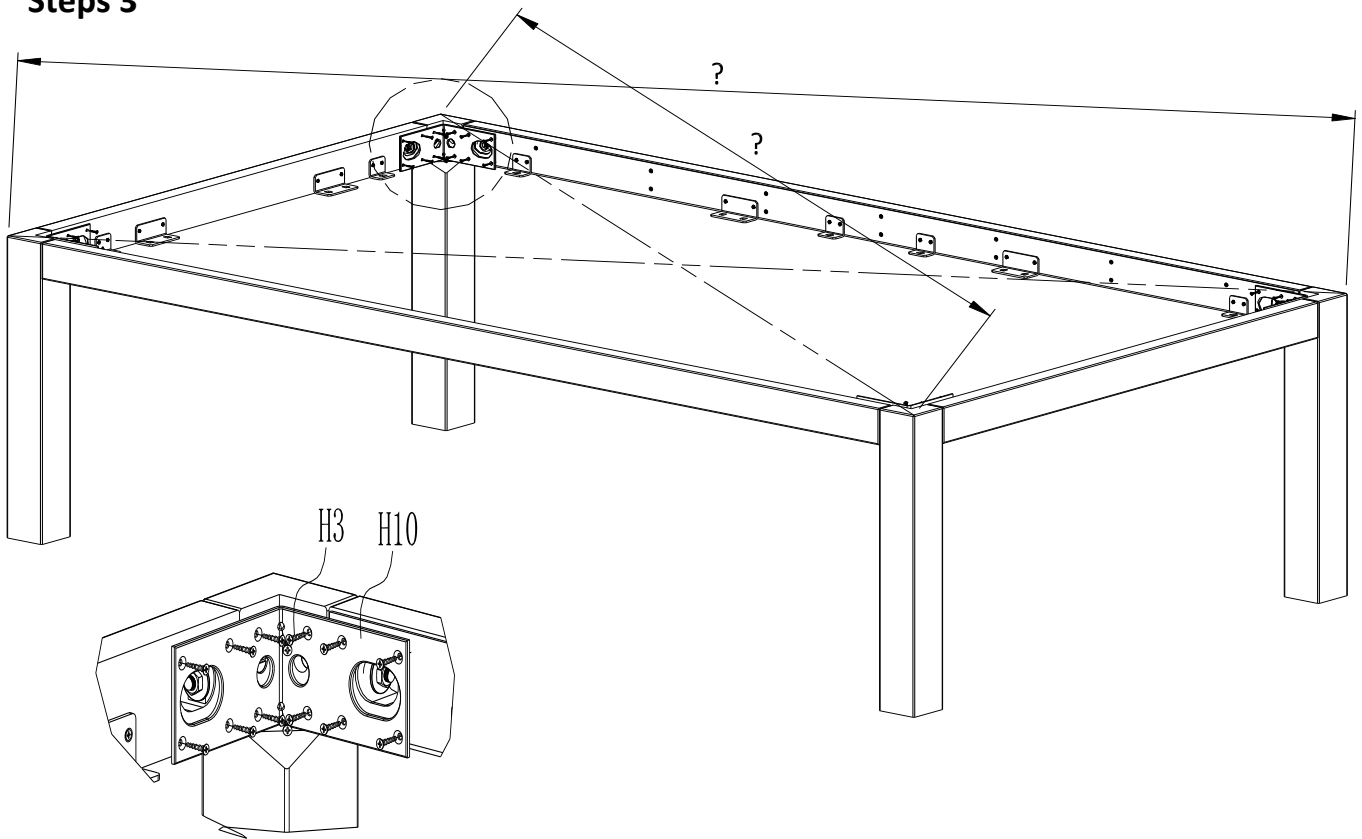

1. Align the angle bar (H10) with the parts from step 2 as shown in the illustration. Attach it using flat head screws (H3). Start by lining up the four holes on the angle bar with the corresponding holes on the long frame. Ensure the angle bar's opposite side is tightly against the short frame's inner side. Fasten securely with the screws (H3). Next, fasten the short frame and table leg together with flat head screws (H3).
2. Refer to the diagram and make sure the lengths of the two diagonal lines are equal or almost equal. Adjust by pushing or pulling the legs or frames of the table until the frame forms a perfect rectangle, NOT a rhomboid. A small variation is acceptable.

Steps 4

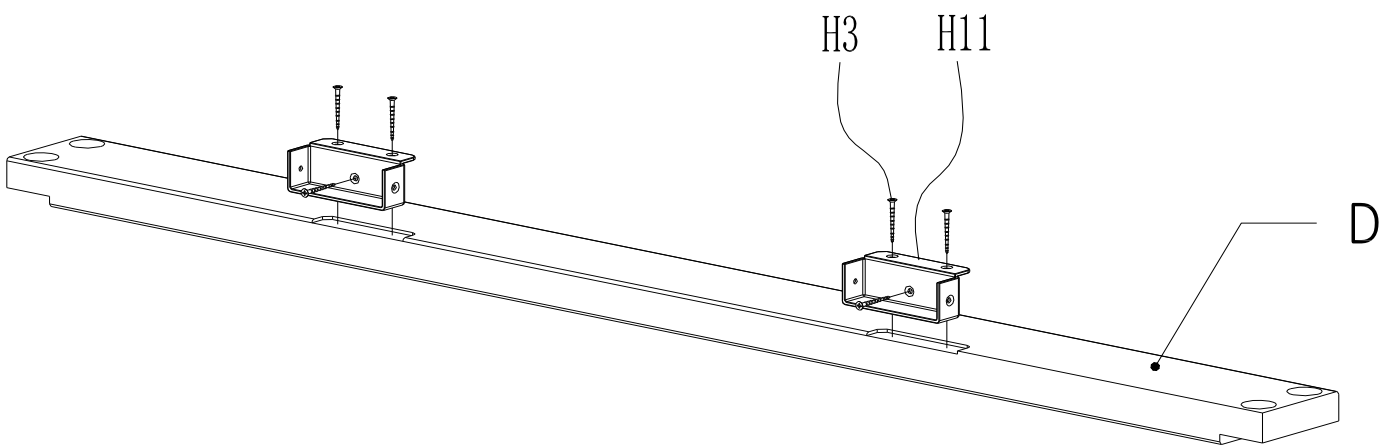

Secure the cross beam support (H11) to the cross beam (D) using a flat head screw (H3) as illustrated in the picture. Note: Ensure that the top of the beam support is level with the top of the cross beam.

Steps 5

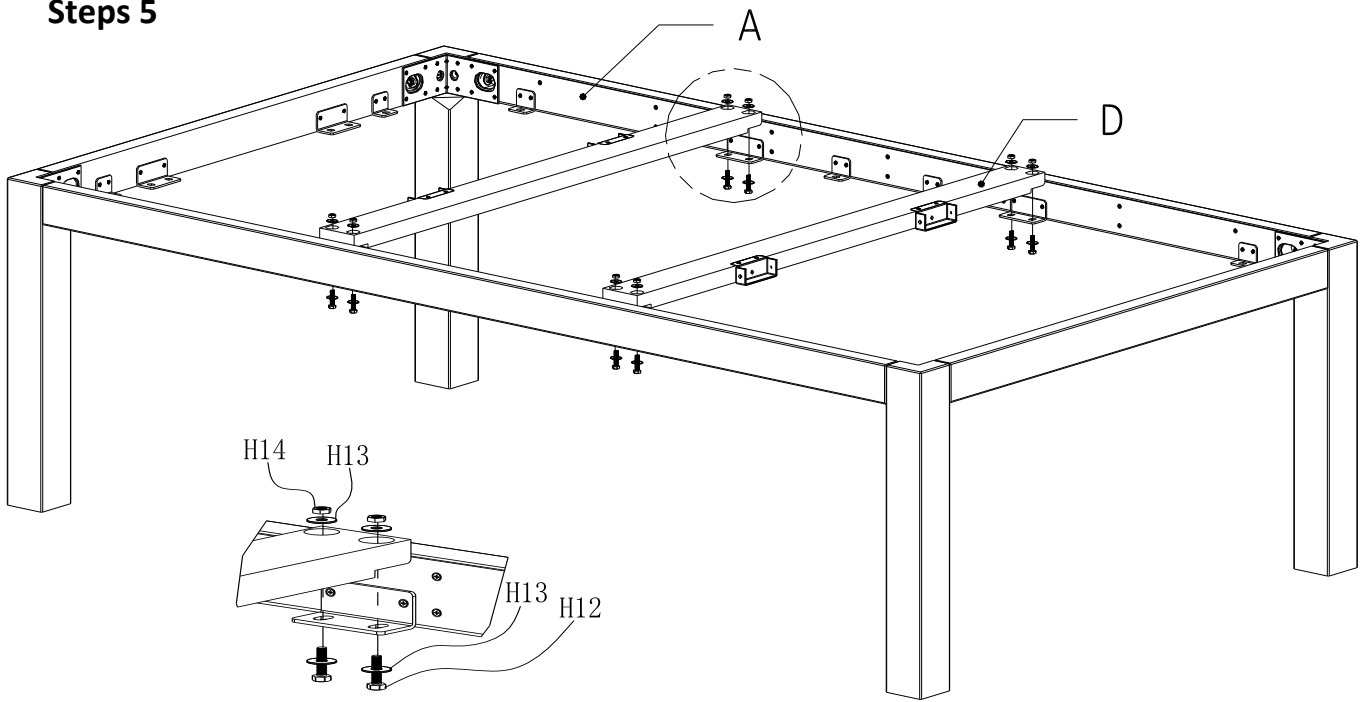

Join the assembled step 3 and the assembled step 4 using hex bolts (H12), flat washers (H13), and nuts (H14) as illustrated in the picture.

Note: During this installation process, it's crucial to ensure that both ends of the crossbeam (D) and ANGLE BAR FOR BEAM (H2) are in contact before tightening the bolts. If one side doesn't make contact, gently push the long frame (A) inward to ensure they touch before securing with bolts.

Steps 6

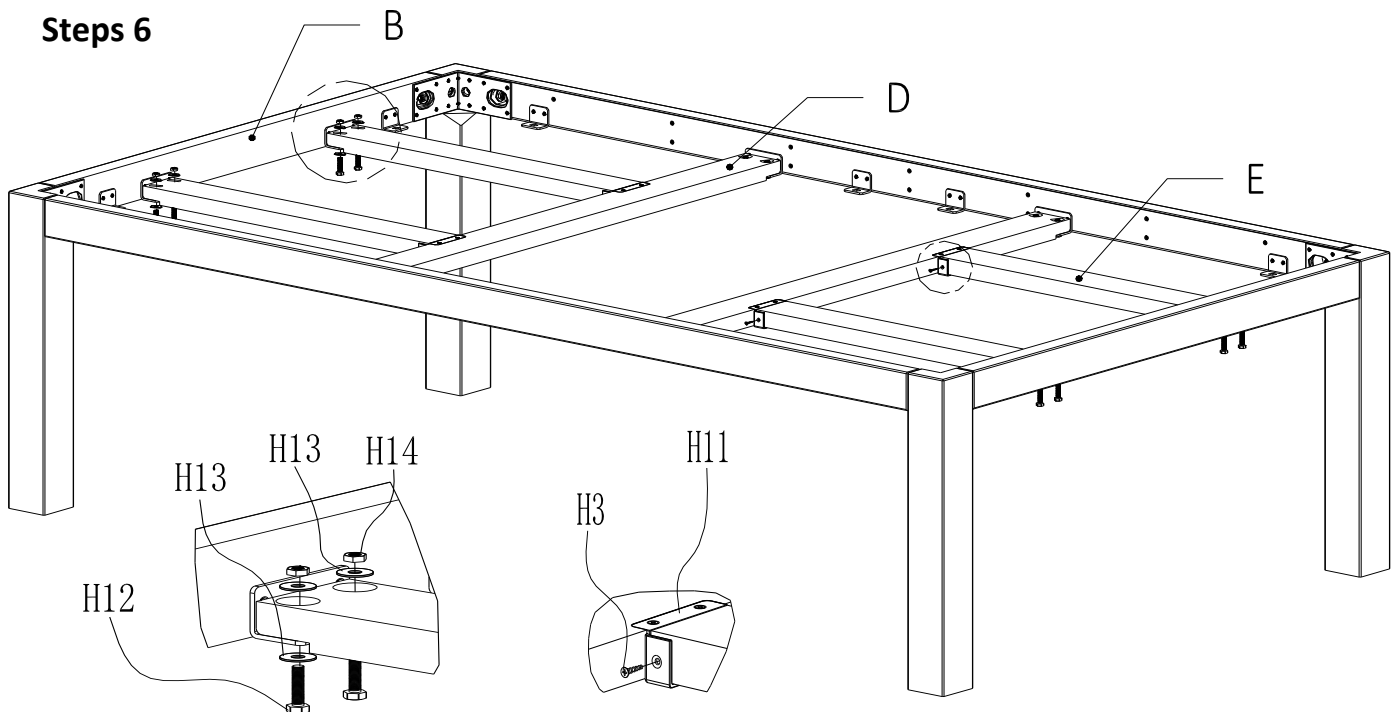

1. Position the side beam (E) according to the illustration and secure it with a hex bolt (H12), flat washer (H13), and nut (H14) at the end of the ANGLE BAR FOR BEAM (H2) in the short frame (B) first. Then, fasten the side beam to the beam support (H11) using a flat head screw (H3).

Note: When installing, ensure that the top surface of the side beam is level with the top surface of the cross beam.

2. If your floor is not so even, you can adjust the leg levelers in order to make the whole table frame in better level before placing the slate on top.

Steps 7

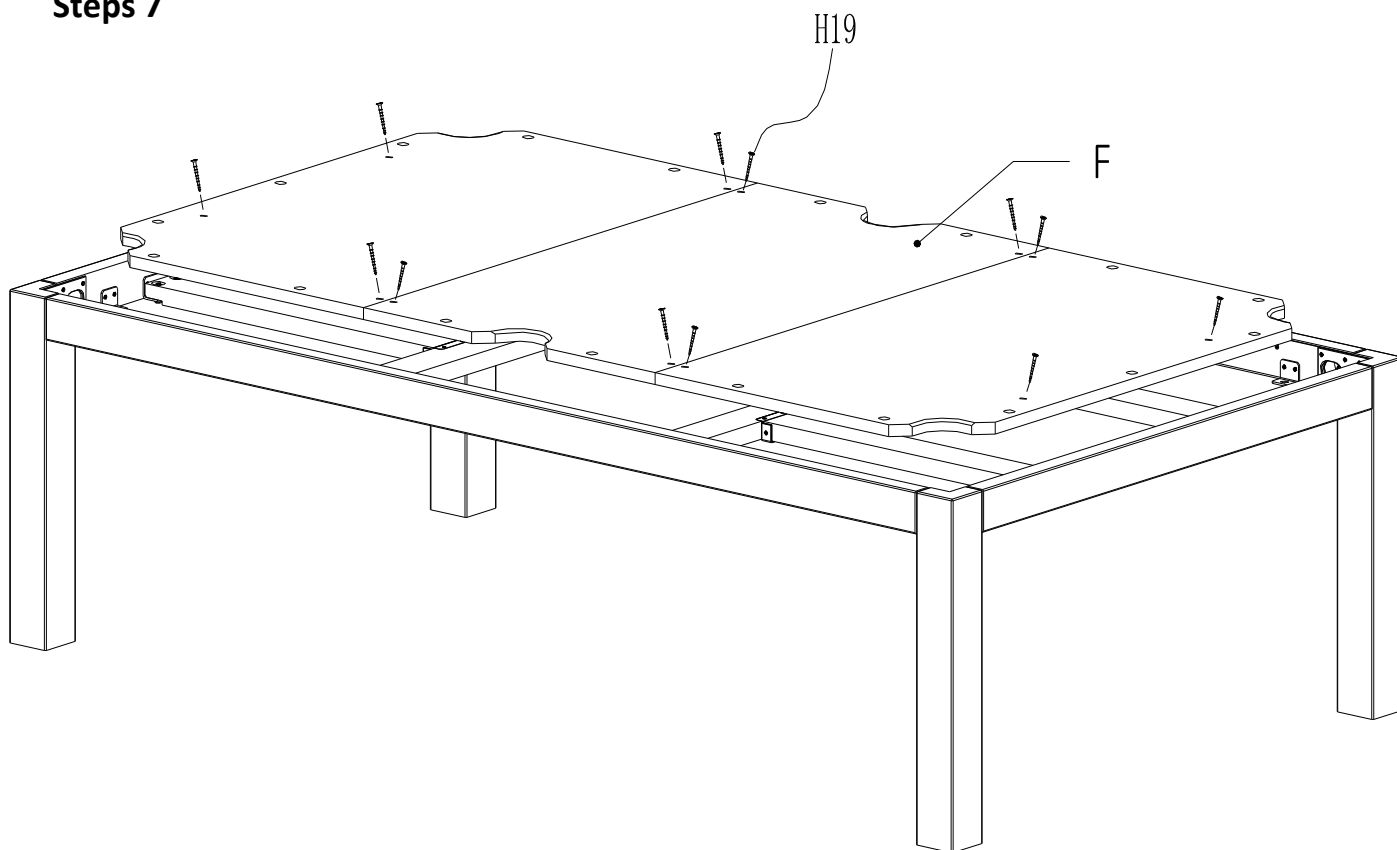

1. Leveling a pool table slate is a specialized task that requires the expertise of a professional pool table installer. If you desire professional-level horizontal flatness for your pool table, it is strongly recommended to seek the services of a qualified pool table installer, if you do want to DIY, you can learn more about "how to level a pool table slate" by watching the video at this link: <https://youtu.be/V-GfbSnjGtg?si=ykYpvu3N6UWGZZvr>, please use the included poker cards in stead of wooden shim.

2. Position the slate on top of the table frame and center it within the table frame. Ensure that the distance between the edges of the slate and the long frame is consistent, and the same goes for the short frame. Then, level all the 3 pieces of slate before securing it in place using the wooden screws (H19).

Note: If the slate pieces are not level with each other, you can insert some poker cards (H30) between the slate and the beams to increase the height as needed. (Please use a high-precision level to measure the horizontal alignment of the three slate pieces; the level is not included here.)

Steps 8

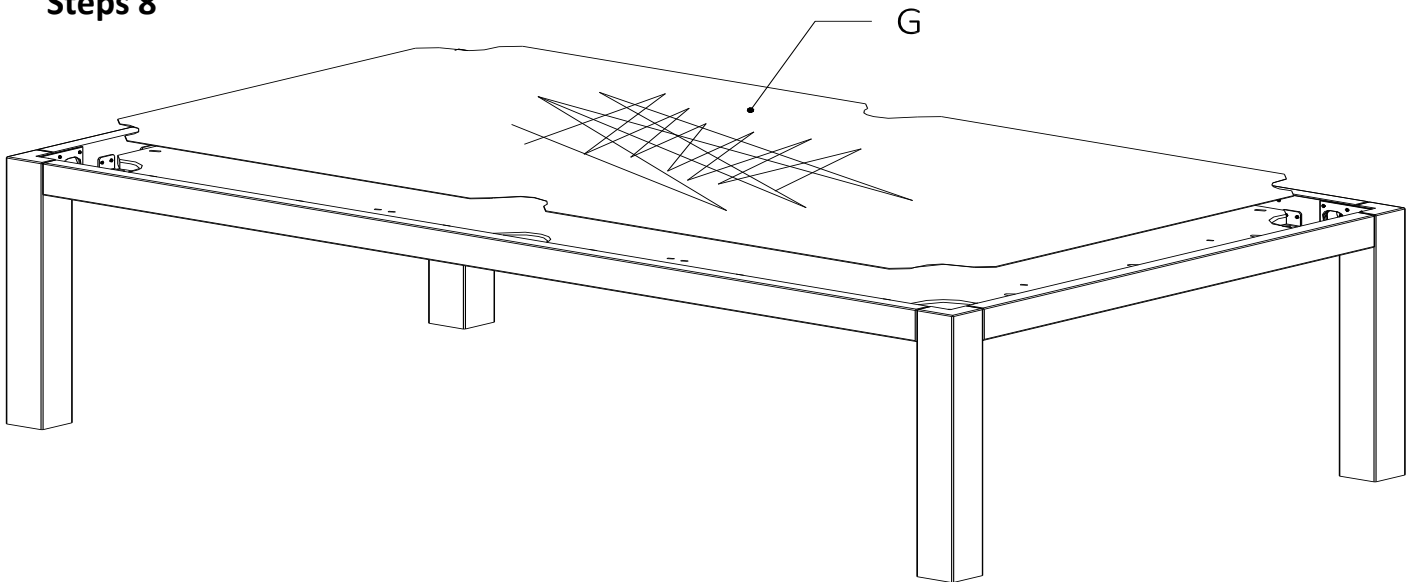

1. Clean the debris on the slate surface, and fill with Beeswax(not included with the product) , (you can learn more about this process by watching the video at this link: <https://www.youtube.com/watch?v=wZmM9sJeCXc>) and sanding until the slate surface is smooth or without any gap between the piece of slate.

2. Clothing a pool table is a highly specialized task, especially when it comes to upholstering the cushion rails. This process requires the expertise of a professional pool table installer. If you're attempting this for the first time, it is strongly advised not to do so and instead, seek the services of a qualified pool table installer. If you want to DIY, you can learn more about it by watching the 3 videos at the 3 links below before you go:

<https://www.youtube.com/watch?v=9vOJueCdVYU&t=35s>

<https://youtu.be/HM480HPvNjs?si=bqp3G8qaA0TeIkzW>

https://youtu.be/bous6ShN_W8?si=DABTiRBRDbrwWTzJ

To secure the cloth, use the included 3M Super 77 adhesive (H31) on both short ends of the slate and the felt. Ensure a smooth and tight bond by pressing them together firmly. Repeat this process for both long sides of the slate.

Note: If you're using water-resistant felt that comes in a roll, handle it with care to avoid wrinkles, as they can potentially damage the water-resistant coating.

Steps 9

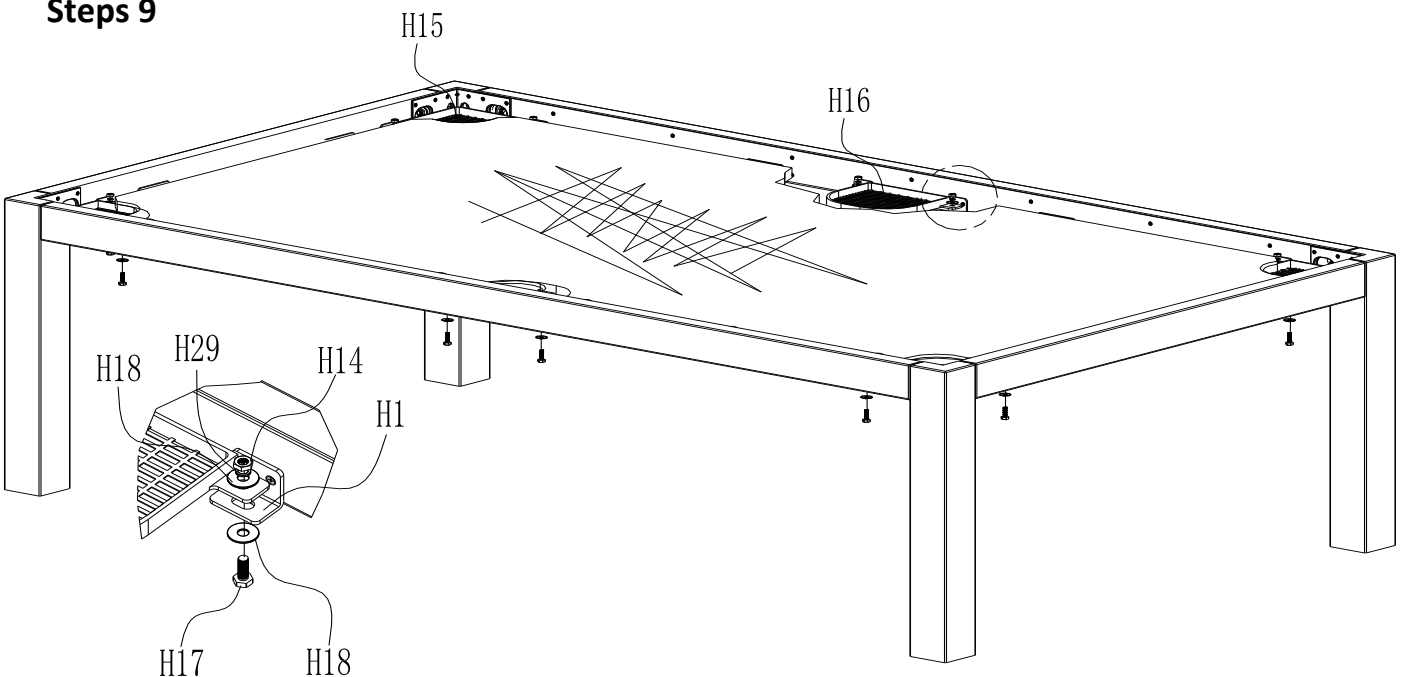

Installed the pocket (H15,H16) on the ANGLE BAR (H1) with hex bolt(H17),flat washer(H18) 、 spring washer (H29) and nut (H14).

Note: 1. The washers(H18) need to be 2 pieces for each bolt.

Steps 10

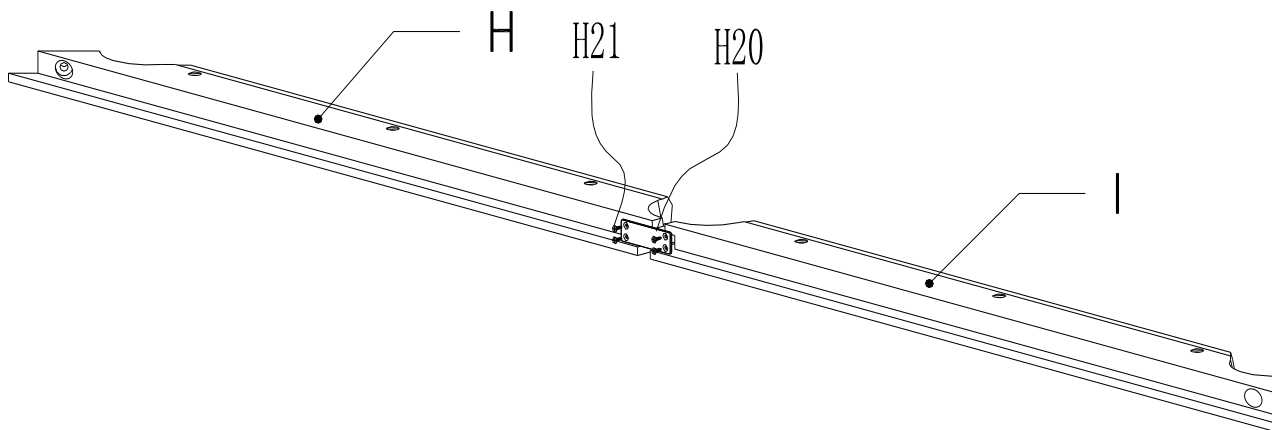

Placing the table side rail #2 & #5 (H) and #3 & #6 (I) on a flat, protected surface to avoid damage from sharp objects. Note: While the wood grain is natural, you can adjust their positions for a better overall look.

Next, connect them together using the metal connector (H20) and flat head screw (H21) according to the picture.

When installing, before fully tightening the bolts, there are four key tips to make your pool table more professional:

1. All rail surfaces should be as level as possible. This can be ensured if the assembly is placed on a relatively flat surface.
2. The two connected side rails (H,I) should be aligned as straight as possible.
3. The joints between each rail should be as neat and tight as possible.

Steps 11

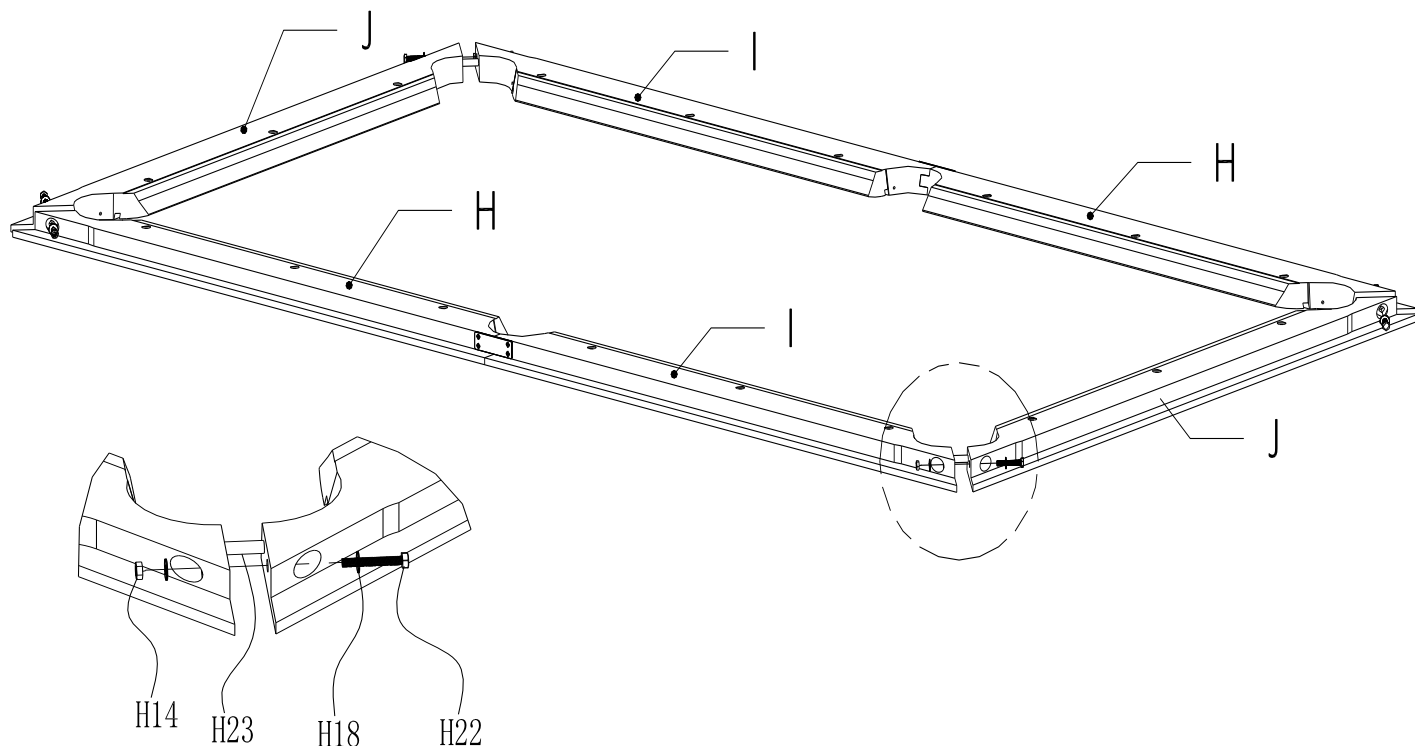

Note: While the wood grain is natural, you can adjust their positions for a better overall look.

1. Securely fasten assembled components from step 10 to the short rail (J) using the provided hardware (wood plug H23, hex bolt H22, flat washer H18, and nut H14), as illustrated in the picture.

When installing, before fully tightening the bolts, there are four key tips to make your pool table more professional:

1. All rail surfaces should be as level as possible. This can be ensured if the assembly is placed on a relatively flat surface.
2. The two connected side rails (H,I) should be aligned as straight as possible.
3. All the rails should be connected to form a standard rectangle as closely as possible.
4. The joints between each rail should be as neat and tight as possible.

Steps 12

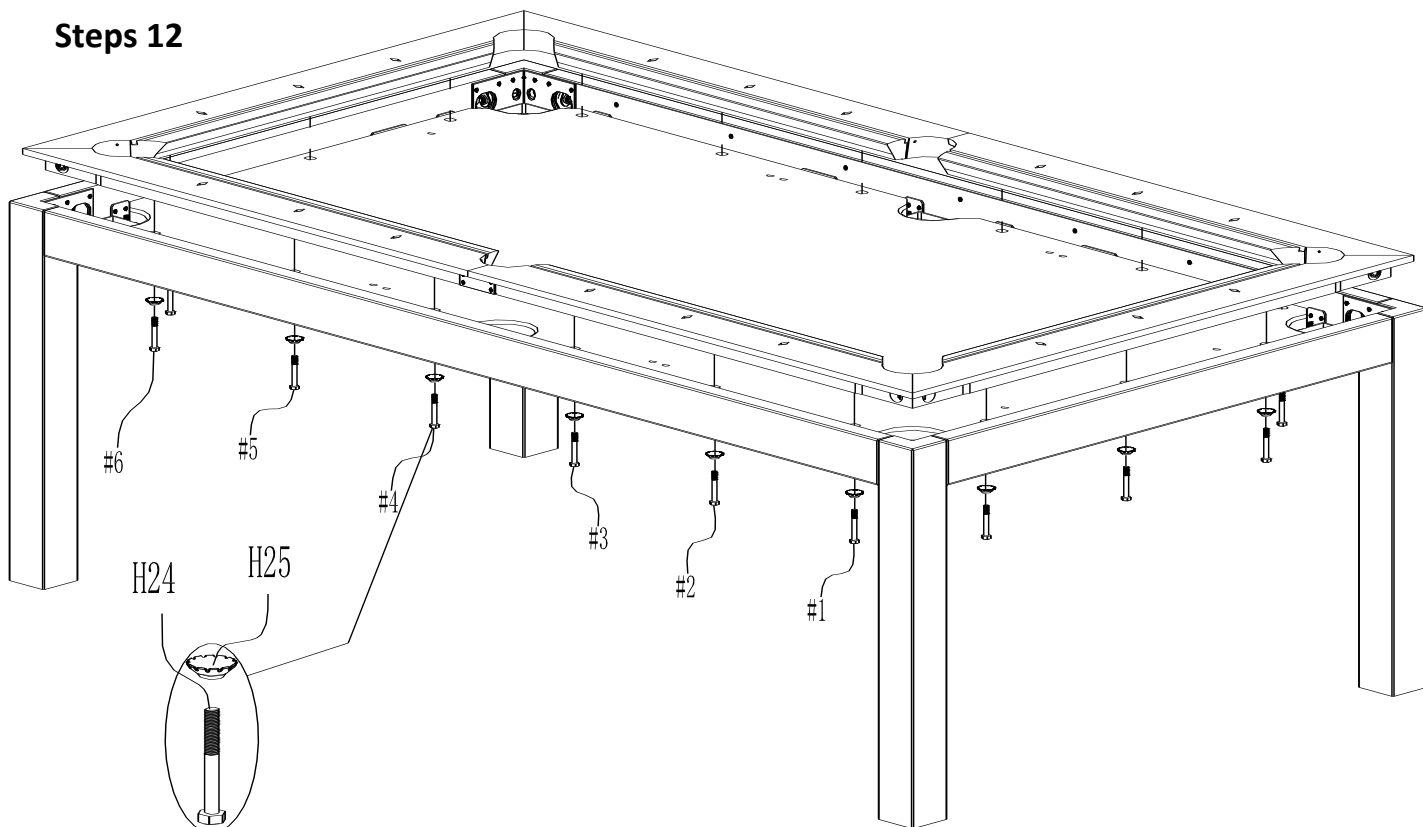

1. After you complete (step 11), flip it 180 degrees and place it on the slate as shown. This process requires 2 or more individuals. Exercise caution during the rotating process to ensure that the two connections between the top rails (H) and top rail (I) remain intact.

2. Ensuring it is centered within the slate (E) and aligns with the table frame.

Note: It's crucial to maintain precise alignment during this step. Verify that all rails (H), (I), and (J) are level, straight, and without noticeable gaps. Additionally, strive to align the wood rail pocket center with the slate pocket center as closely as possible. Ensure that the distance between the outer sides of top rails (H) & (I) and the outer sides of the long frame remains consistent. The same applies to the short frame.

3. Then, align the table side rails (H, I) in a straight line and use hex bolt (H24) and dome washers (H25) to connect the table rails by passing through the holes in the slate (F).

Caution: To align the side rail (H, I), first tighten bolts #1 and #6. Then, adjust them by pushing them inwards or outwards at the middle pocket position until its rubber cushion nose lines up straight. Once aligned, fully tighten bolts #3 and #4, and then secure bolts #2 and #5. Repeat the same steps for the opposite side rails (H, I), and finally tighten the two end rails (J).

Steps 13

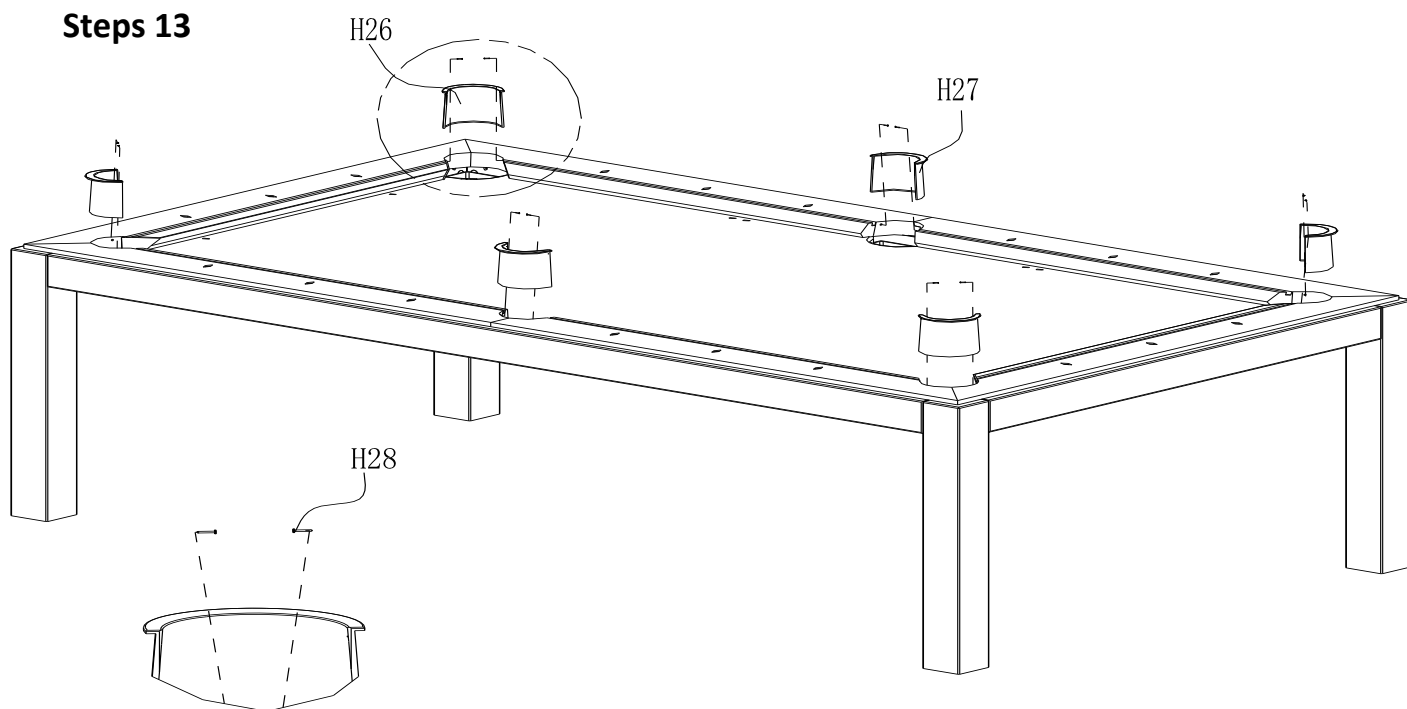

1. Install pocket (H26) for the corner pocket and (H27) for the side pocket.
2. Secure each pocket using 2 stainless nails (H28) apiece.

Complete

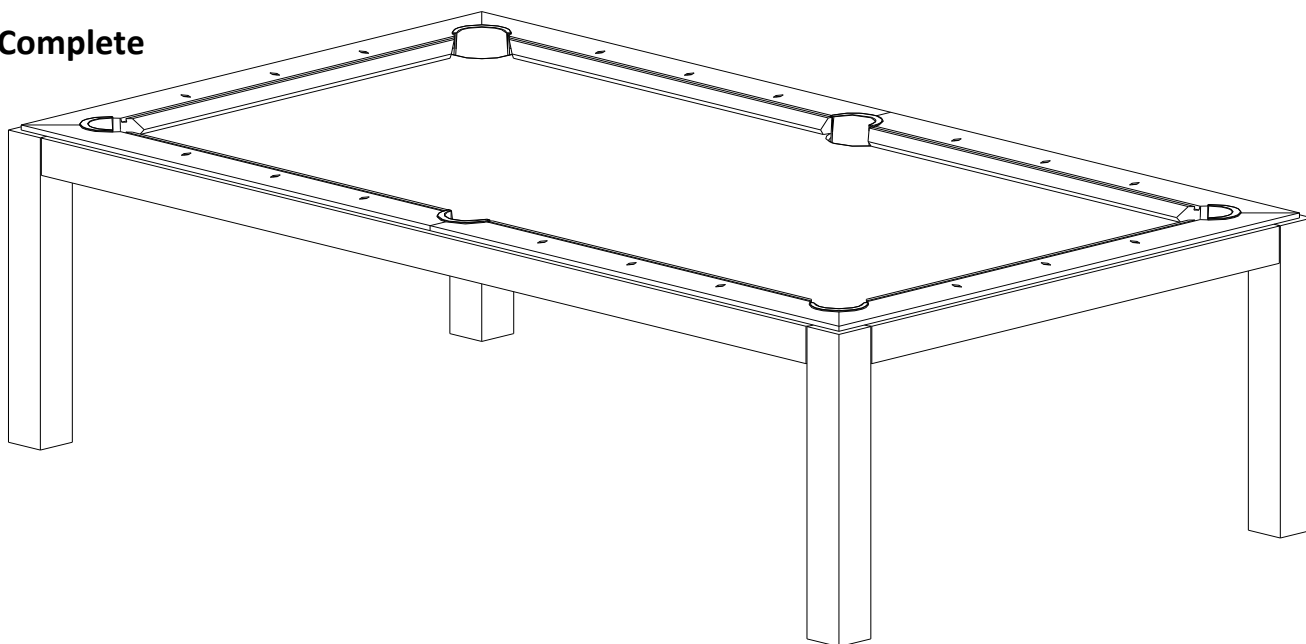

Note: If you want to Mark Your Pool Table - Head Spot, Foot Spot, and Line, please you can learn more about it by watching the video at this link: <https://www.youtube.com/watch?v=GK9rvf09imk>

Customer Service

If you have any questions about assembly, or if you find parts missing or damaged, please email us at sales@homeseasoninc.com or call us at 626-838-6008

Thank you for choosing Homeseason!