

GEORGE FOREMAN®

3 BURNER GAS BBQ GFGBBQ3BW

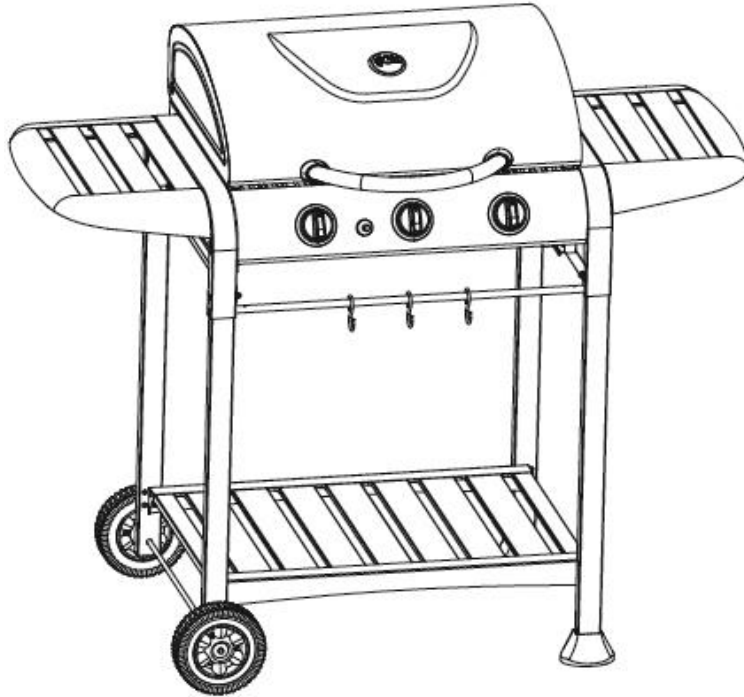

Please scan the QR code for step by step video assembly instructions. Alternatively, you can visit: bbqs.georgeforeman.co.uk. From here, please select the product that you are looking to build and view the 'How To' video located at the bottom of the page.

WARNING: PLEASE ENSURE YOU HAVE READ THROUGH THE SAFETY AND OPERATING INSTRUCTIONS BEFORE USE.

PLEASE RETAIN INSTRUCTIONS FOR FUTURE REFERENCE

CONTENTS

	Page(s)
Safety Instructions	3-5
BBQ Parts List & Feature Diagram	6-7
BBQ Assembly	8-23
Connecting Gas Cylinder	24
Disconnecting Gas cylinder	25
Lighting your BBQ	26
Food Safety	27
Tips for use	28
Storage	29
Cleaning and Care	30
Troubleshooting	31 - 32
Guarantee and Customer Services	33
Notes	34-35

SAFETY INSTRUCTIONS

WARNING: IMPORTANT SAFETY INSTRUCTIONS

READ CAREFULLY AND KEEP FOR FUTURE REFERENCE

- The Barbeque must be installed on a secure level base prior to use.
- Read the instructions before using the appliance.
- Always light the barbecue with the lid open.
- Check and clean the grease trays regularly.
- The gas hose should be checked regularly for leaks (especially after long breaks).
- Never use water to extinguish flames.
- Turn off the gas supply at the gas cylinder after use.
- Any modification to the appliance may be dangerous and will void the guarantee.
- Do not store or use gasoline or mentholated fuels or any other flammable vapors and liquids in the vicinity of this appliance. Never light a gas grill with gasoline or similar flammable fluids!
- When the wind speed is above 2m/s do not use the appliance facing in to the wind, as this may cause the flame to extinguish.
- Never mount the gas cylinder under the appliance or near any parts of the appliance which becomes hot as this could result in serious injury.
- Use protective heat resistant gloves when handling particularly hot components.

- The appliance must be installed with 1m clearance in all directions around the appliance and should not be used underneath any overhead obstruction.
- In the event of a gas leak, turn off the gas supply at the gas cylinder, extinguish any open flames and keep the lid open. If the leak continues contact your local gas dealer immediately.

DO NOT USE AN OPEN FLAME TO CHECK FOR GAS LEAKS

- Always test the gas line for leaks with soapy water. If there are leaks you should see bubbles forming.
- Be prepared, if an accident or fire should occur. Know where the first aid kit and fire extinguishers are and how to use them.
- Do not heat any unopened glass or metal container on the grill. Pressure may build up and cause the container to burst, possibly resulting in serious personal injury or damage to the appliance.
- **WARNING:** This barbecue will become very hot, do not move it during operation.
- **WARNING:** Do not use spirit or petrol for lighting or re-lighting! Use only firelighters complying to EN 1860-3!
- **WARNING:** Keep children and pets away.
- **WARNING:** Do not use the barbecue in a confined and/or habitable space e.g. houses, tents, caravans, motor homes, boats. Danger of carbon monoxide poisoning fatality.

SAFETY CHECKS BEFORE USE

- **WARNING:** If you smell gas, shut off gas to the appliance, extinguish any open flames and open lid. If the odour continues, keep away from the appliance and immediately call your gas supplier or your fire department. Leaking gas may cause a fire or explosion which can cause serious bodily injury, death, or damage to property.
- Never operate this appliance unattended, always ensure there are at least two people present.
- Check the hose before each use for nicks, cracking, abrasions or cuts. If the hose is found to be damaged in any way, do not use the grill.

Technical data

UK CA 0359-24		GEORGE FOREMAN 3 BURNER GAS BBQ WITH WOOD EFFECT SHELVES GFGBBQ3BW UKCA Pin Code: 0359DP00126		
Country of Destination	Appliance Category	Gas and Supply Pressure	Main burner Injector Size Ø	Total Nominal Heat Inputs (Hs)
GB	I3+(28-30/37) <input checked="" type="checkbox"/>	Butane(G30) 28-30 mbar	0.86mm	9.0 kW 654g/h
		Propane(G31) 37 mbar	0.86mm	9.0 kW 642g/h
CE 0063-24		CE Pin Code: 0063CN7292		
Country of Destination	Appliance Category	Gas and Supply Pressure	Main burner Injector Size Ø	Total Nominal Heat Inputs (Hs)
BE,CH,CY,CZ,ES,FR,GB,GR,IE,I T,LT,LU,LV,PT,SK,SI	I3+(28-30/37) <input checked="" type="checkbox"/>	Butane(G30) 28-30 mbar	0.86mm	9.0 kW 654g/h
		Propane(G31) 37 mbar	0.86mm	9.0 kW 642g/h
BE,CY,DK,EE,FI,HU,LT,NL,NO,S E,SI,SK,RO,HR,TR,BG,LU,MT	I3B/P(30) <input type="checkbox"/>	Butane/Propane 30 mbar	0.86mm	9.0 kW 654g/h
AT,CH,DE,SK	I3B/P(50) <input type="checkbox"/>	Butane/Propane 50 mbar	0.75mm	9.0 kW 654g/h
PL	I3B/P(37) <input type="checkbox"/>	Butane/Propane 37 mbar	0.82mm	9.0 kW 654g/h

Use outdoors only.
Read instructions before using the appliance.
The gas cylinder should not be placed inside the BBQ.
Warning : Accessible parts may be very hot. Keep young children away.
Made in China
Made by Product Care Trading Limited under license from Spectrum Brands (UK) Limited.
Product Care Trading Limited, Wigan, WN2 4AY/PCT (NI) Ltd, Belfast, BT5 5AD.
George Foreman is the registered trademark of Spectrum Brands (UK) Ltd.

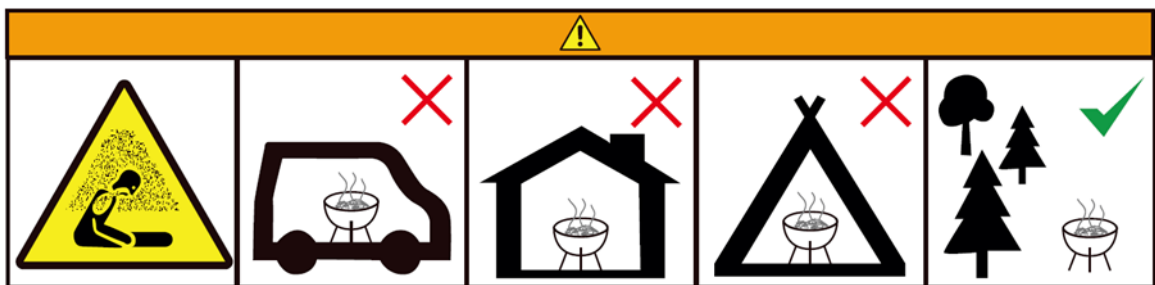

Carbon Monoxide
Poisoning Hazard





























Do not use in
Motor Homes

Do Not Use
Indoors

Do Not Use in
Tents

Use in open
Spaces

BBQ PARTS LIST

1 X 2(R) 	2 X 1 	3 X 2 (L) 
4 X 1(L) 	5 X 1(L) 	6 X 1(R) 
7 X 1(R) 	8 X 2 	9 X 1 
10 X 2 	11 X 1 	12 X 1 
13 X 3 	14 X 2 	15 X 1 
16 X 1 	17 X 1 	18 X 3 
19 X 1 	20 X 1 	21 X 1 
22 X 1 	23 X 1 	
A X 32 	B X 8 	C X 6 
D X 6 	E X 2 	F X 2 

You will need:



PART	DESCRIPTION	QTY
1	Right Leg	2
2	Lower shelf	1
3	Left Leg	2
4	Top left leg assembly (Left)	1
5	Support bracket (Left)	1
6	Support bracket (Right)	1
7	Top right leg assembly (Right)	1
8	Leg Cap	2
9	Wheel Axle	1
10	Wheel	2
11	BBQ Main Body	1
12	Tea Towel Rail	1
13	Hook	3
14	Side Shelf	2
15	Drip Tray	1
16	Oil Cup Support	1
17	Oil Cup	1
18	Heating Diffuser	3
19	Cooking Grill	1
20	Cooking Grill	1
21	Warming Rack	1
22	Thermostat	1
23	Gas Hose Connector	1
A	M5 10mm Bolt	32
B	M5 50mm Bolt	8
C	M5 Nut	6
D	Tension Washer	6
E	Pin Clip	2
F	Bushing	2

FEATURE DIAGRAM

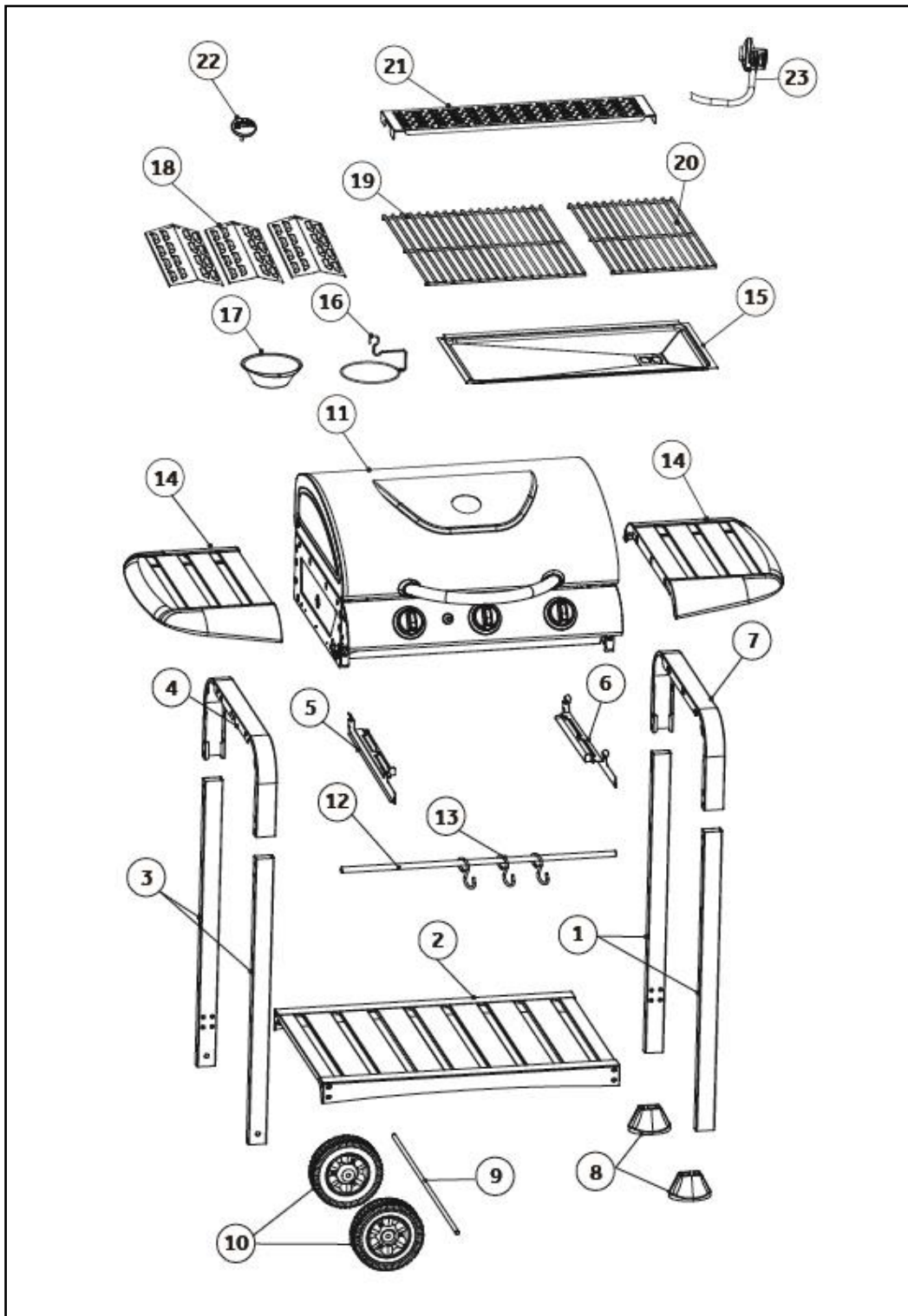

BBQ ASSEMBLY

STEP 1 – Constructing lower shelf

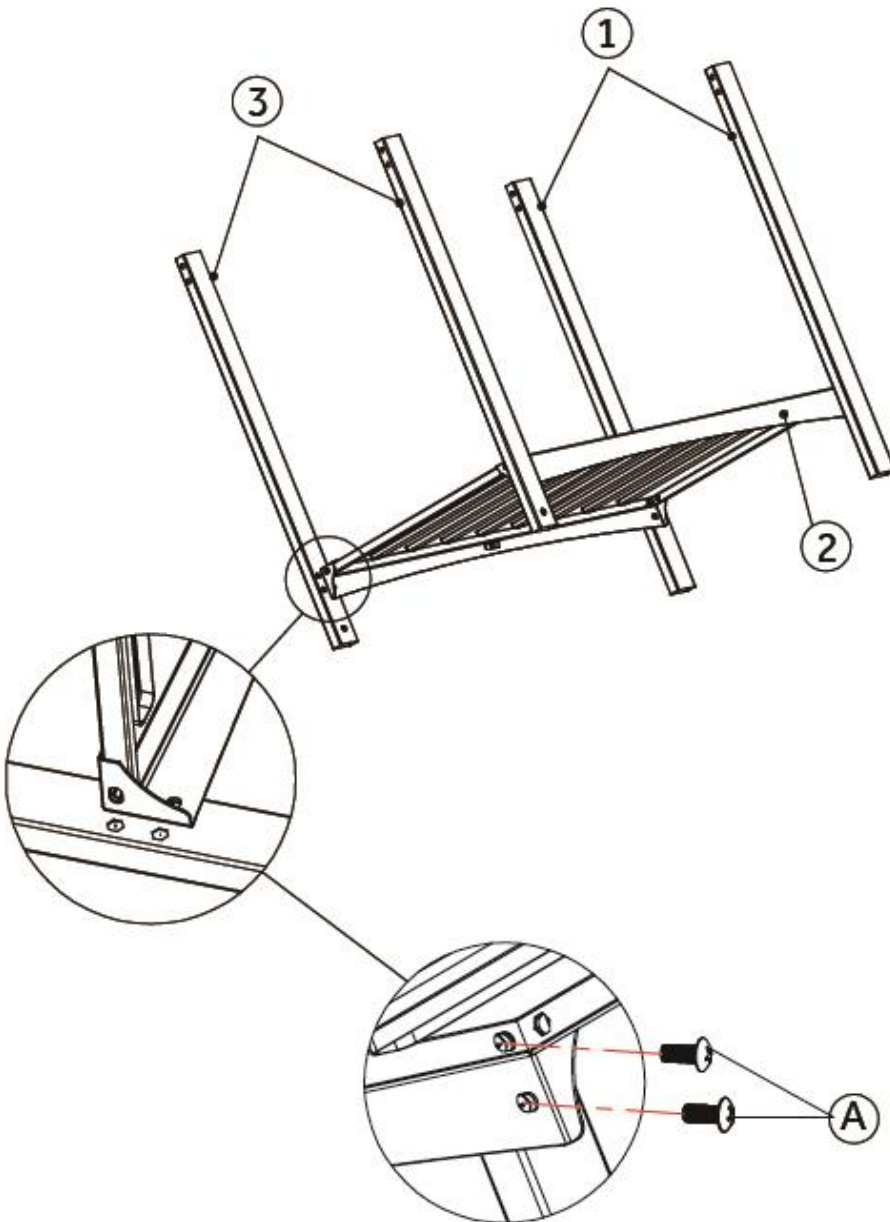
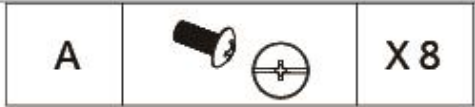

- Attach **Right Leg (1)** and **Left Leg (3)** to **Lower Shelf (2)** using A bolts.
- Ensure two bolt holes are left exposed next to where the legs are attached.



BBQ ASSEMBLY

STEP 2 – Attaching side supports – left hand side

- Attach the **Top Left Leg Assembly (4)** and **Left Support Bracket (5)**.
- Ensure the support bracket is attached as shown on the inside face of the upper leg assembly.

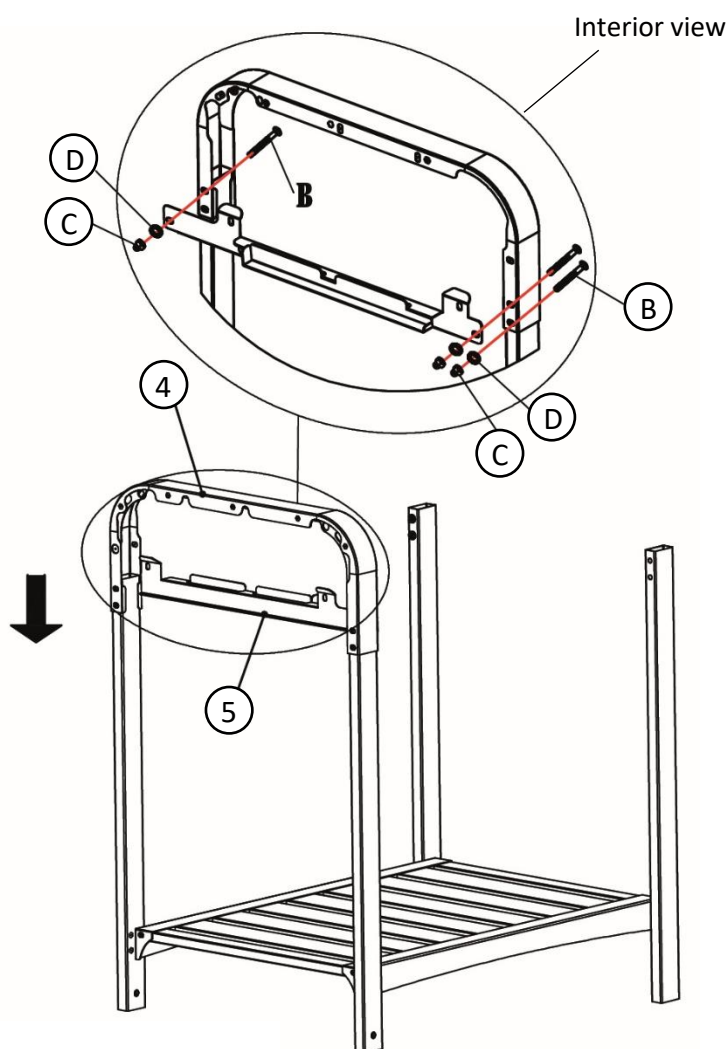

B		X 3
C		X 3
D		X 3



BBQ ASSEMBLY

STEP 3 – Attaching side supports – right hand side

- Repeat previous step for right hand side.
- Tighten the screws, bolts and nuts using a screwdriver and adjustable spanner.

B		X 3
C		X 3
D		X 3

Interior view

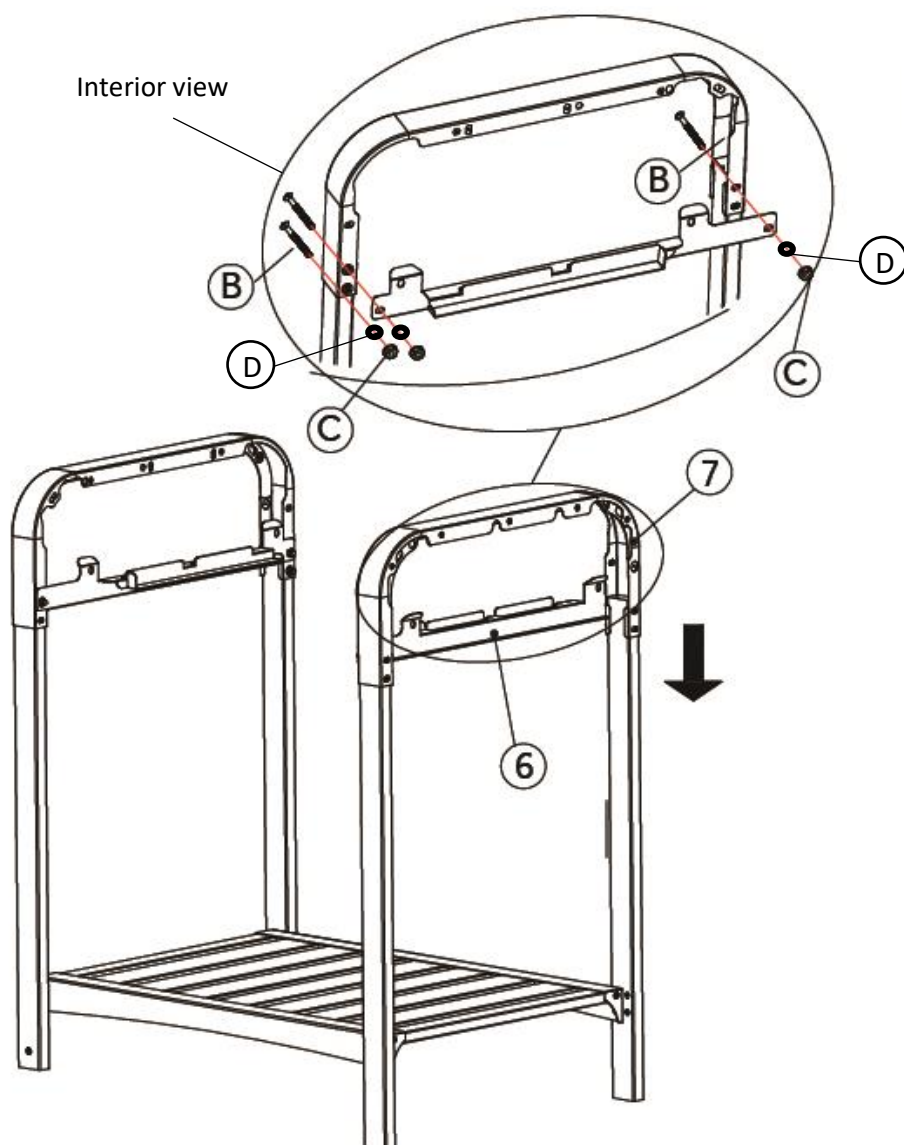

BBQ ASSEMBLY

STEP 4 – Attaching leg caps

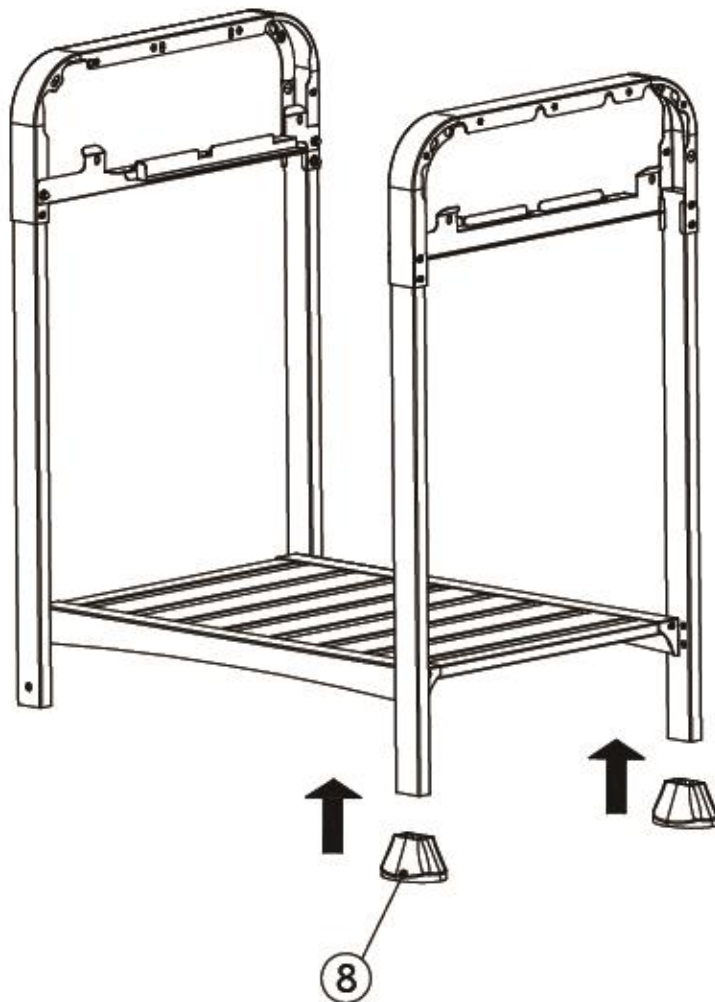

- Attach **Leg Caps (8)** to the bottom of the **Right Legs (1)**.
- Push to fit.



BBQ ASSEMBLY

STEP 5 – Attaching wheels

- Slide the **Wheel Axel** (9) through the holes at the bottom of the **Left Legs** (3).
- Ensure the **Bushings** (D) are placed on the wheel axel on the outside of legs.
- Place the **Wheels** (10) on the outside of the wheel axel and push the **Pin Clips** (E) through each of the holes at the ends of the wheel axel to secure in place.

D		X 2
E		X 2

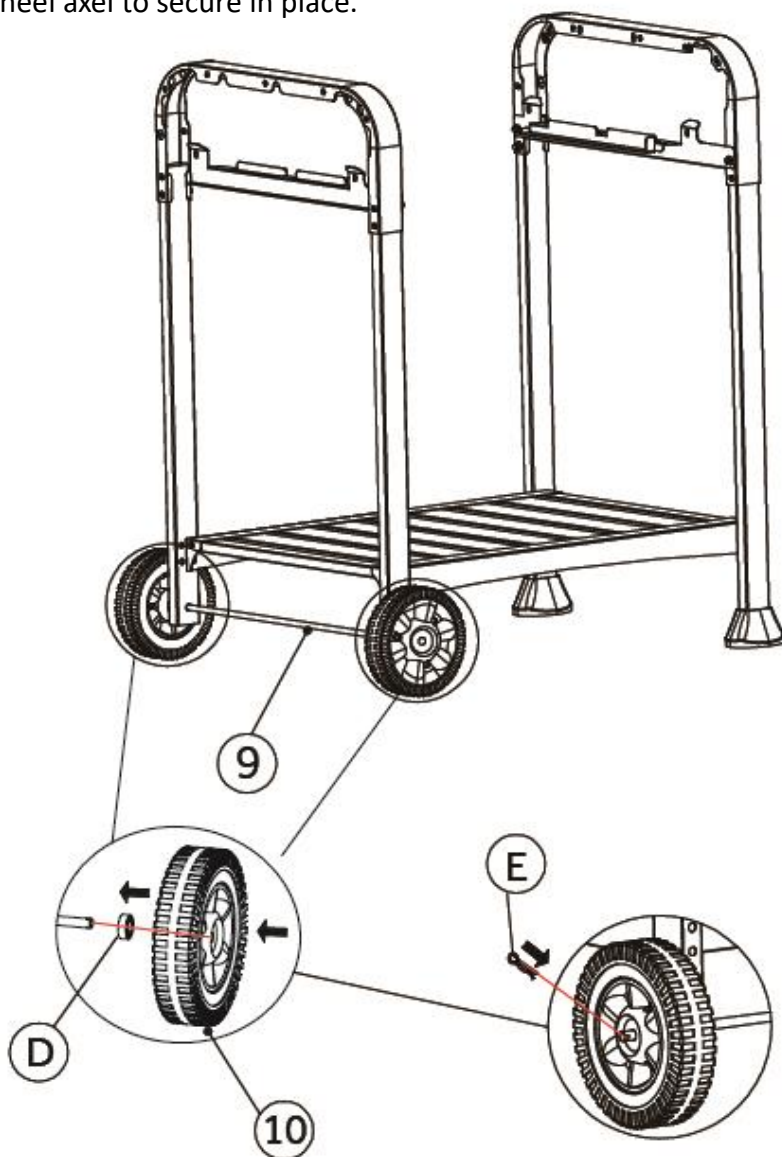

BBQ ASSEMBLY

STEP 6 – Attaching the grill

- Lower in the **BBQ Main Body** (11) ensuring it sits correctly on the support brackets (5) and (6).
- Once in place, proceed to step 7.

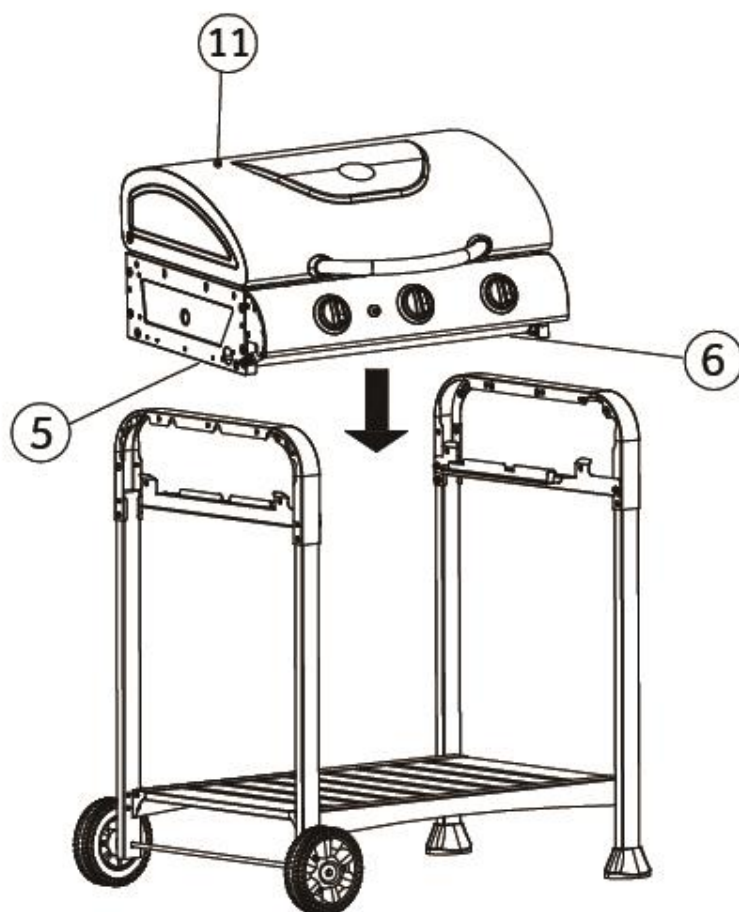

BBQ ASSEMBLY

STEP 7 – Securing the grill

- Attach the **BBQ Main Body (11)** to the **Top Left and Right Leg Assemblies (4)** and (7) on both sides.
- Using a screwdriver, tighten the A bolts to secure in place.

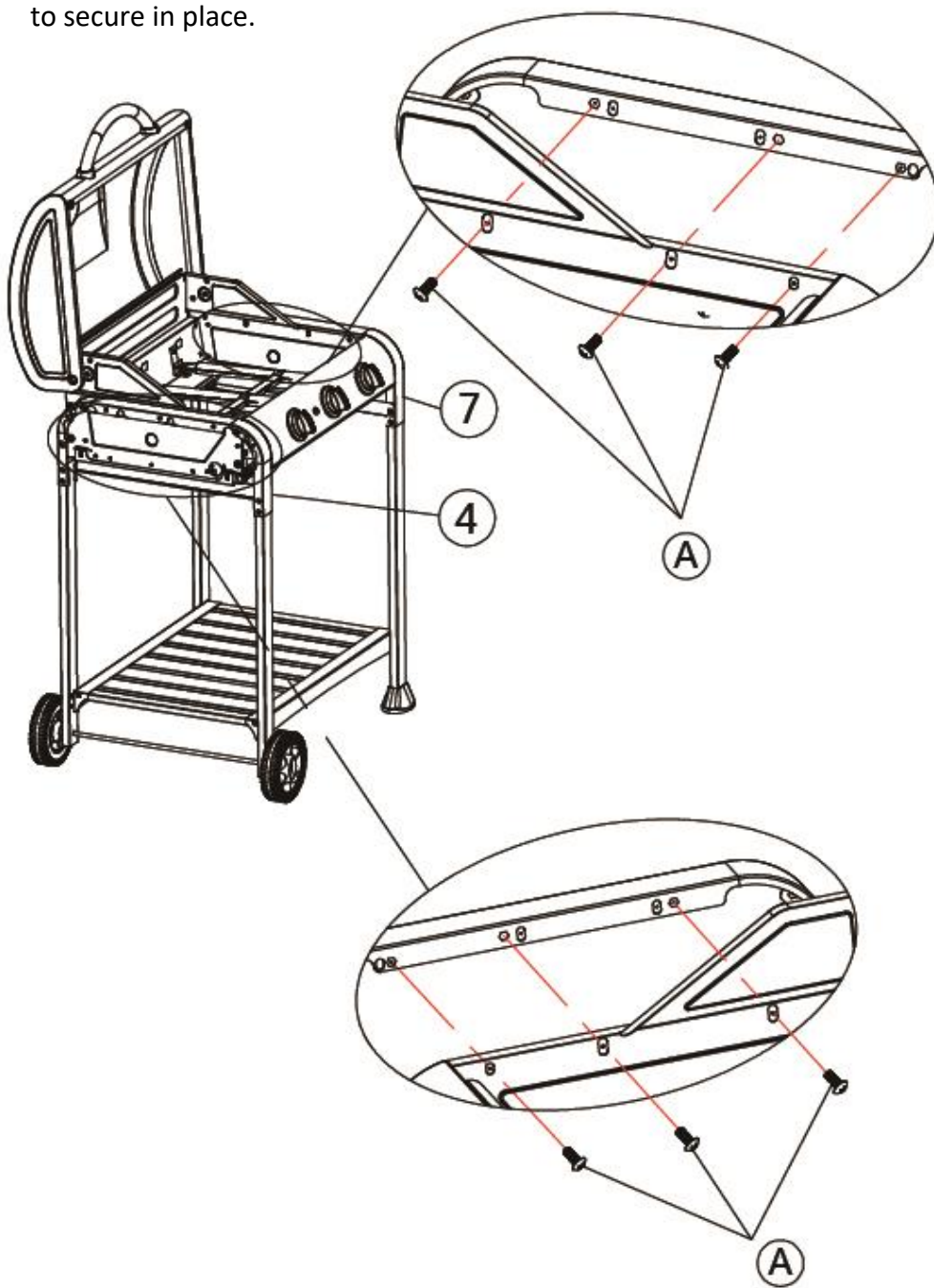
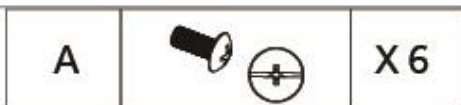

BBQ ASSEMBLY

STEP 8 – Securing the grill

- Secure the **BBQ Main Body** (11) on both sides to the **Top Leg Assemblies** (4) and (7) and **Support Brackets** (5) and (6) as shown.

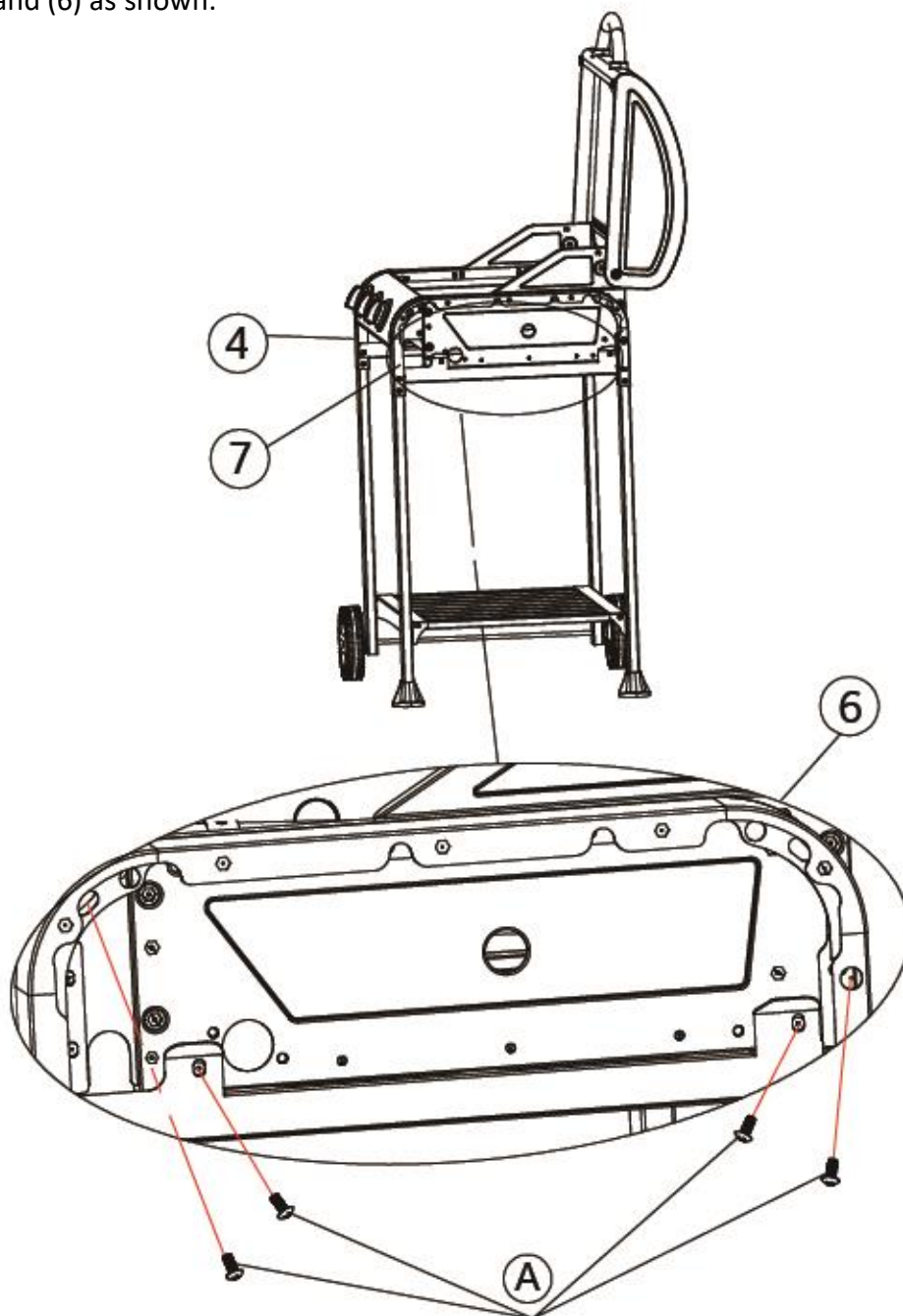

BBQ ASSEMBLY

STEP 9 – Attaching the towel rail

- Ensure the **Hooks** (13) are already placed on the **Towel Rail** (12) before adding to the BBQ.
- Attach the **Towel Rail** with the hooks in place (12) and (13) to the front legs at the top and secure in place with (B) screws.

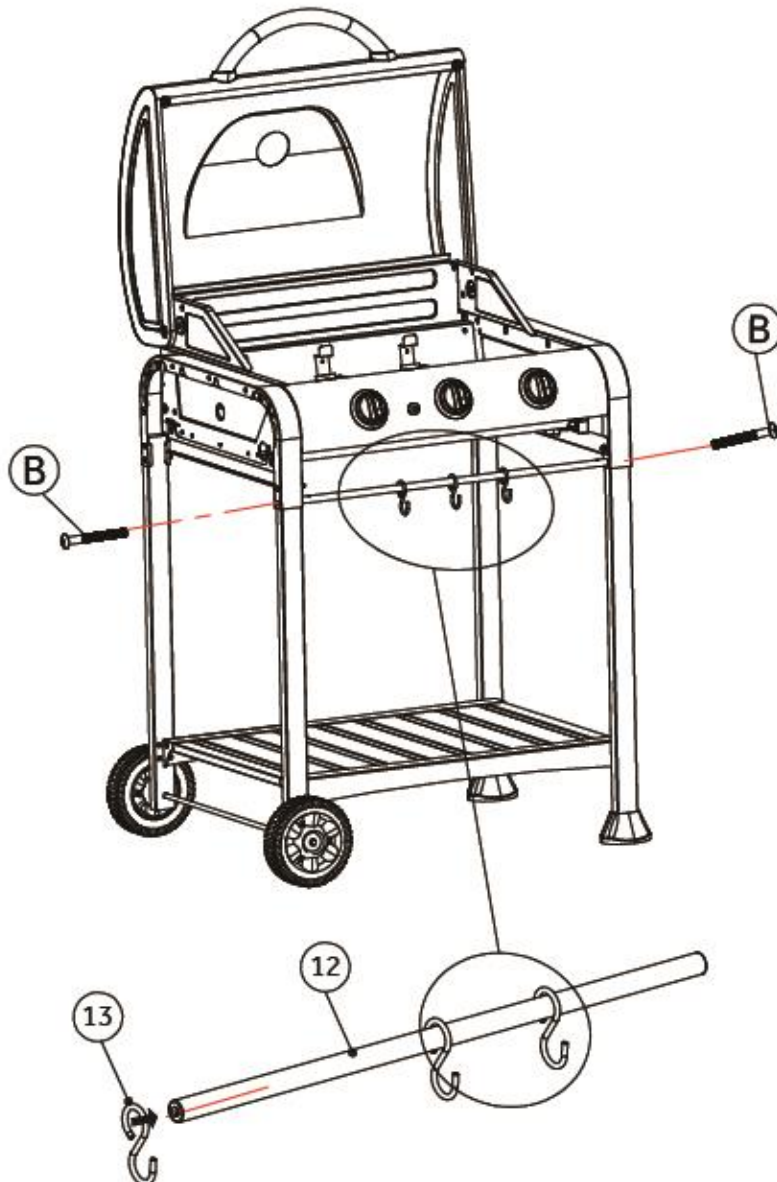

BBQ ASSEMBLY

STEP 10 – Attaching the side shelves

- Partly screw in 3 X A bolts to the **Top Right Leg Assembly (7)** and place one **Side Shelf (14)** on to them.
- Manually bend the sides of the shelf downwards and using two more A bolts secure them in place.
- Once all A bolts are fitted, tighten to fully secure in place and repeat for opposite side.

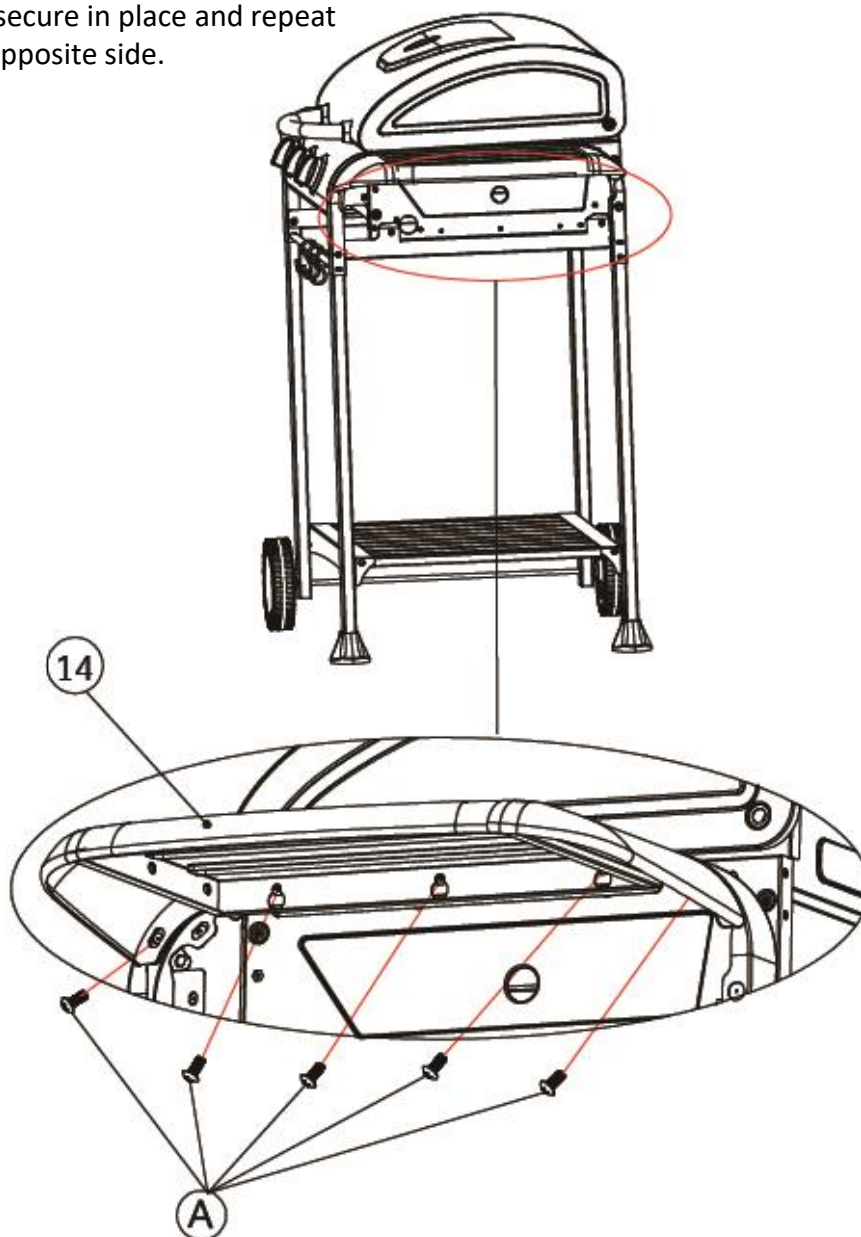
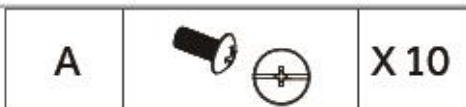

BBQ ASSEMBLY

STEP 11 – Attaching the drip tray

- Slide the **Drip Tray (15)** in to the rear of the BBQ.
- Hook the **Oil Cup Support (16)** and **Oil Cup (17)** on to the drip tray.

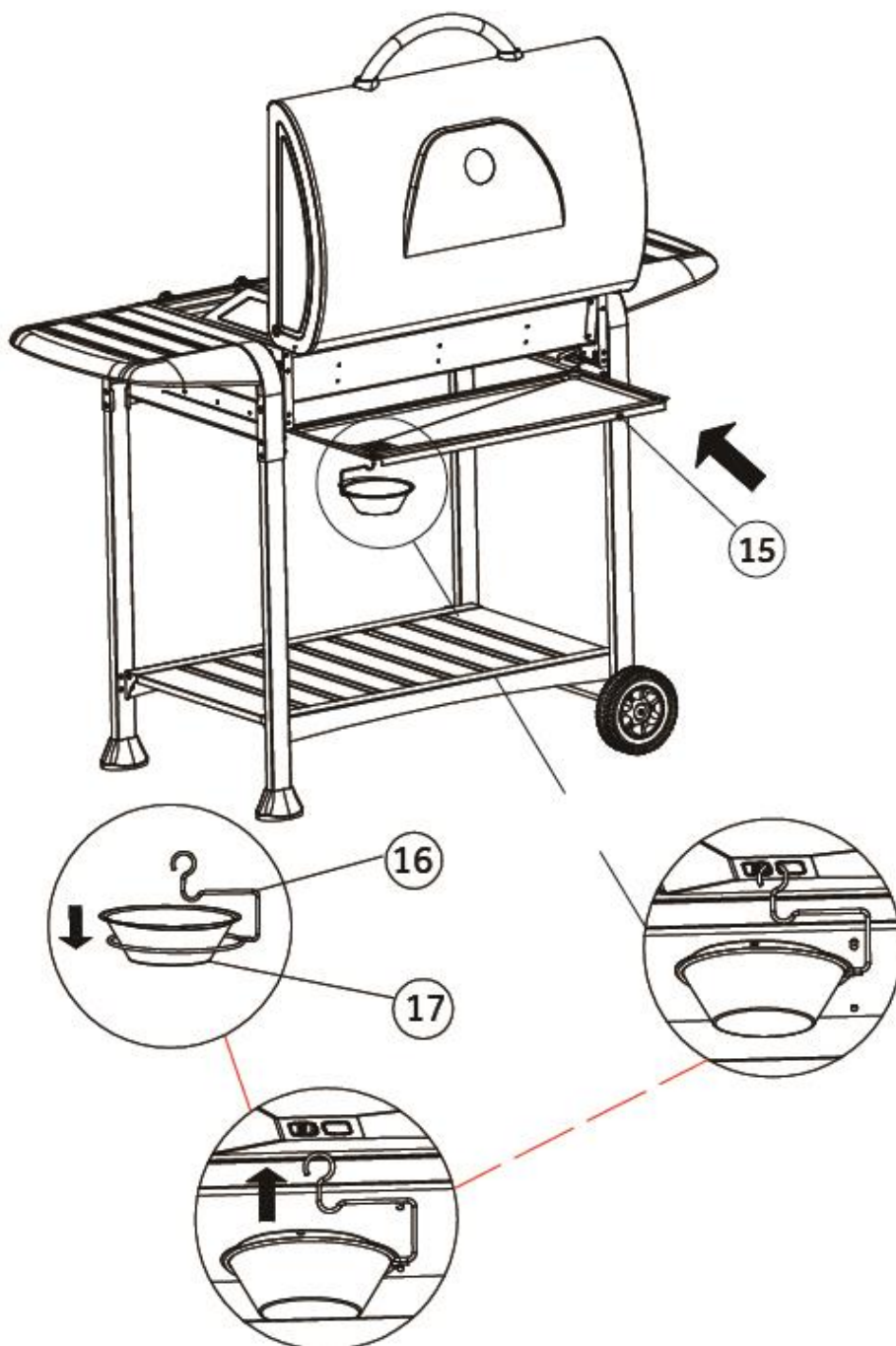

BBQ ASSEMBLY

STEP 12 – Assembling the heating diffusers

- Place the **Heating Diffusers (18)** as shown inside the BBQ main body.

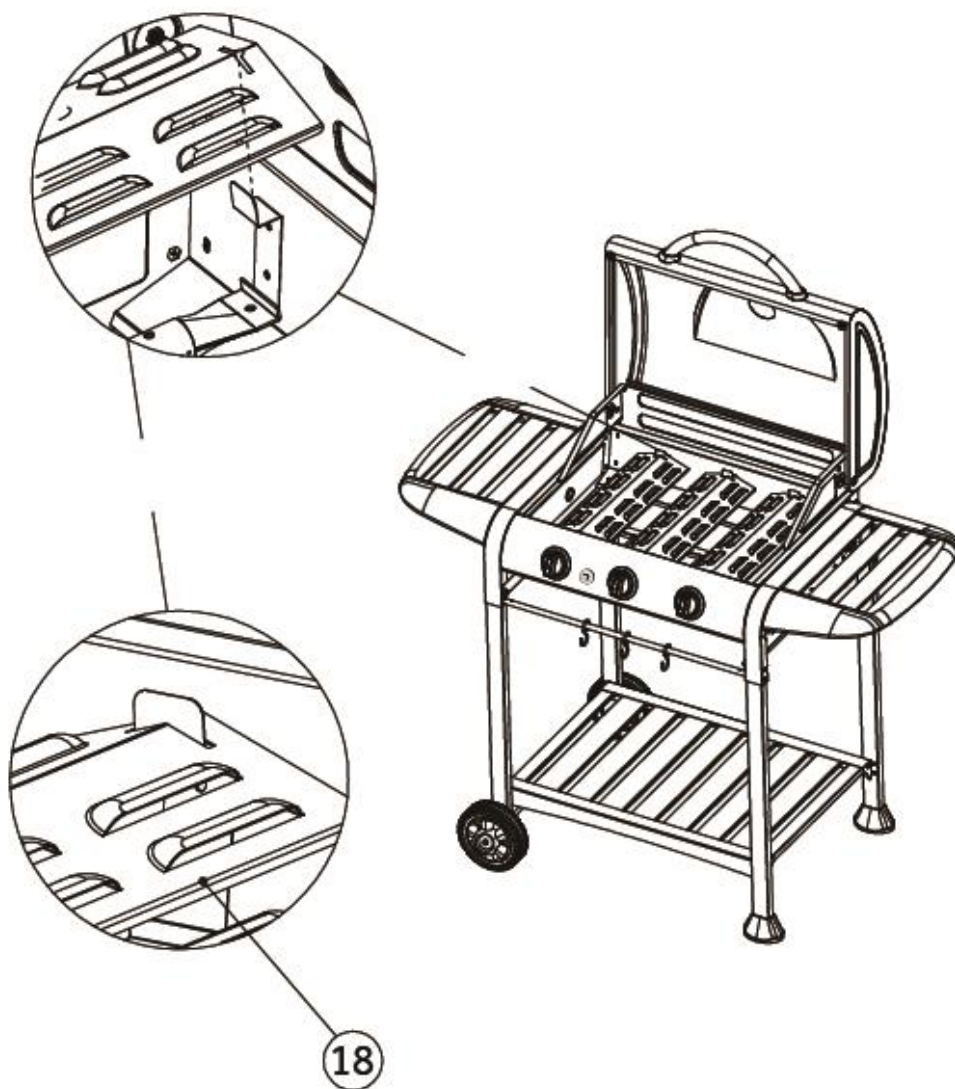

BBQ ASSEMBLY

STEP 13 – Assembling the cooking grills

- Place the **Cooking Grills** (19) and (20) as shown inside the BBQ main body.

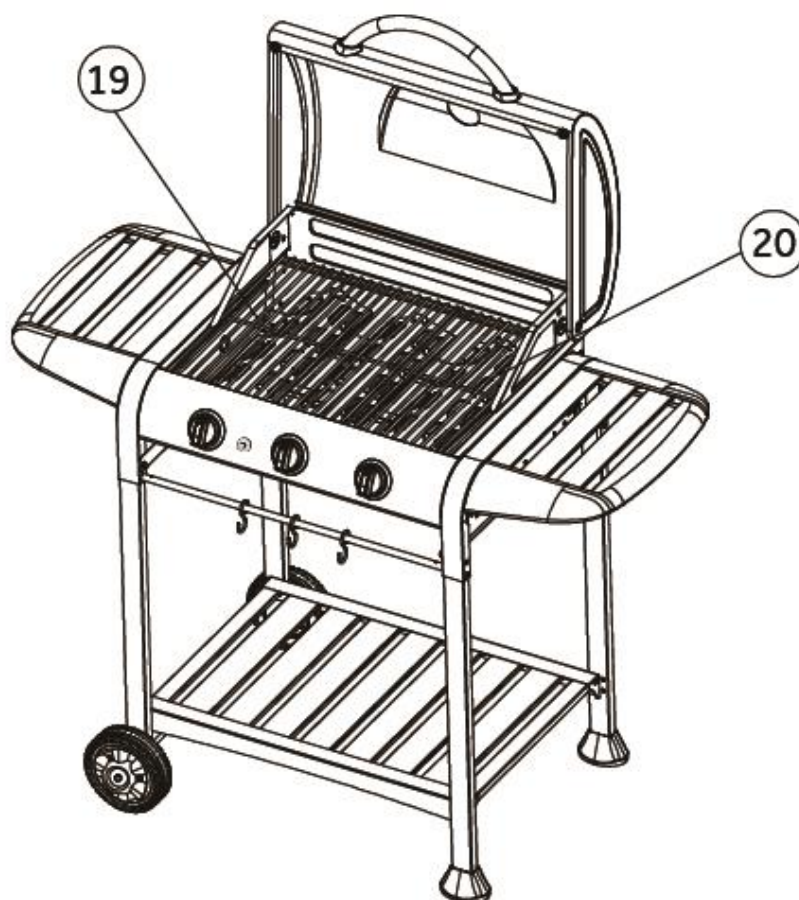

BBQ ASSEMBLY

STEP 14 – Assembling the warming rack

- Remove the protective film from the **Warming Rack (21)** and place on top of the warming rack support inside the BBQ main body.



BBQ ASSEMBLY

STEP 15 – Assembling the thermometer

- Slide the **Thermometer (22)** through the hole in the lid of the BBQ.
- Ensure it is aligned correctly whilst securing it with the wingnut provided.

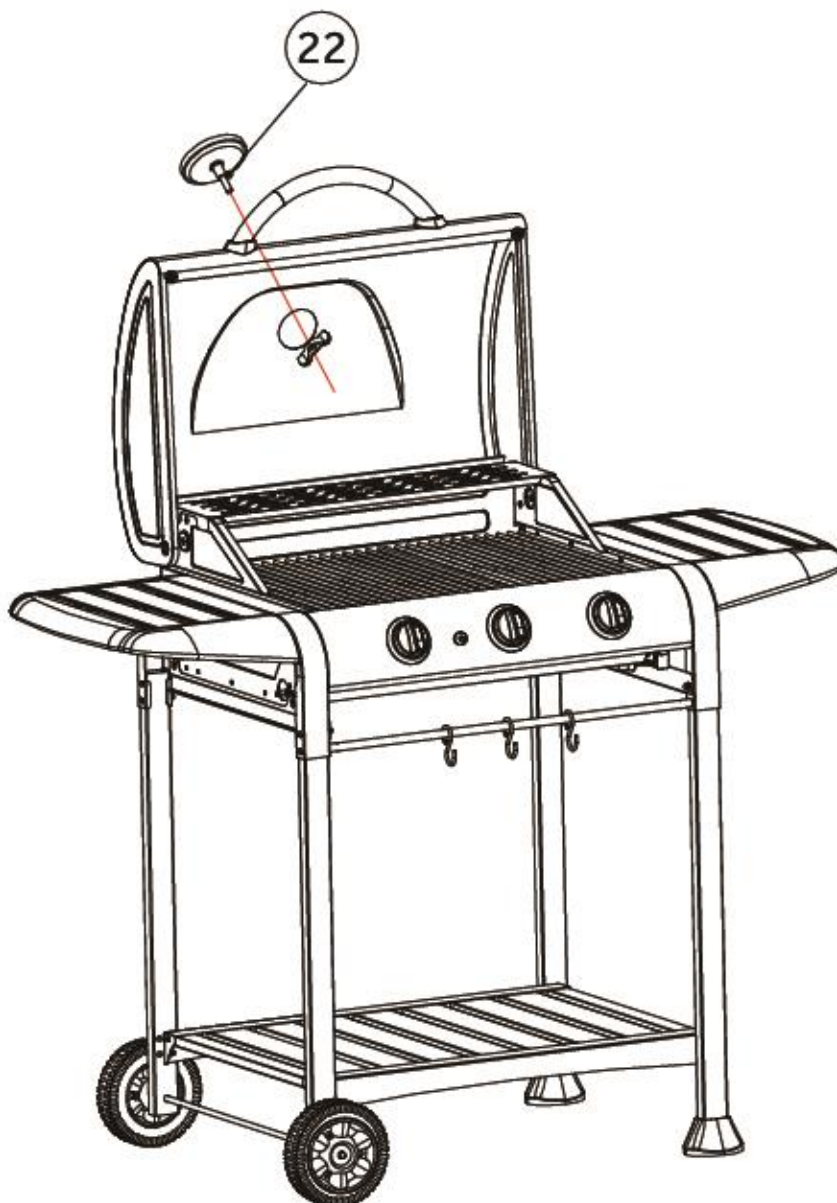

BBQ ASSEMBLY

STEP 16 – Completed BBQ

WARNING: Never place gas tank on shelf underneath BBQ.

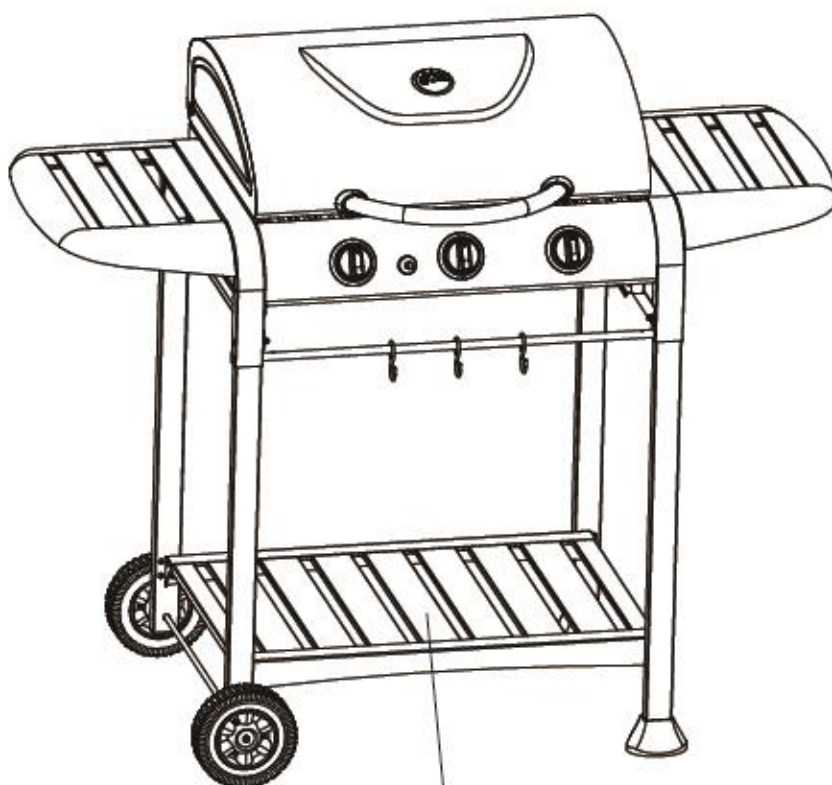

CONNECTING YOUR GAS CYLINDER

After purchasing your gas cylinder, you will need to set it up with your gas BBQ. **When changing the gas cylinder, it must not be near any source of ignition.**

Position the gas cylinder at the left side of your gas BBQ, keeping in mind that the bottle must be kept away from heat and in a safe position.

1. When ready to use your gas BBQ, place the regulator onto the gas bottle valve and push down firmly until you hear it click in to place.
2. Attach the hose to the regulator gas outlet. You will need to push firmly as it is a tight fit.
3. Once the hose is connected to the regulator it must be secured in place using one of the two jubilee clips supplied.
4. Attach the other end of the gas hose to the gas inlet on the BBQ appliance. You will need to push firmly as it is a tight fit.
5. Once the hose is connected, use the second jubilee clip to secure in place.
6. Ensure that the hose is not subjected to twisting which will affect the gas flow when installing your gas BBQ. The hose must not have undue tension and must not touch any part of the gas BBQ, which may be hot.
7. Once the gas cylinder is connected to the appliance, you can then start the flow of gas by turning the small lever on the regulator from its closed position (horizontal) to its open position (vertical).

WARNING: Always test gas line for leaks at connector with soap water around all connections.

DISCONNECTING YOUR GAS CYLINDER

When you have finished using the appliance you must remove the gas cylinder.

1. When you are ready to remove the gas cylinder, turn the small lever on the regulator from its open position (vertical) to its closed position (horizontal).
2. Once the gas supply has been turned off, you then need to remove the regulator from the gas cylinder.
3. To remove the regulator, push in the button release (located below the small lever on the regulator) and lift away from the gas cylinder.

LIGHTING YOUR BBQ USING THE AUTOMATIC IGNITION

WARNING: The lid must be open when lighting the BBQ. Do not stand with your face directly over the gas grill when lighting it.

1. Ensure the dial is in the "OFF" position.
2. Turn the gas cylinder valve to the "ON" position at the regulator.
3. To create a spark, press the control dial (A) into the BBQ and hold in position for 3-5 second to allow the gas to flow. Then turn the control dial anticlockwise to "HIGH" (B). This will create a spark to the burner lighting tube (C) and this should make a "snap" sound and produce an orange flame from the burner lighting tube at the left side of the burner (D)
4. Continue to hold the control dial in position for a further 2 seconds to allow the gas to flow (E) and ensure ignition.
5. On the "HIGH" setting, the flame should be approximately 12-20mm high with an orange flame. Turn the gas control fully anticlockwise for the minimum heat setting.

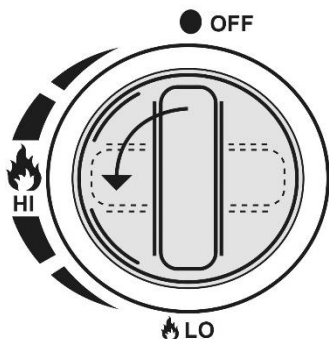
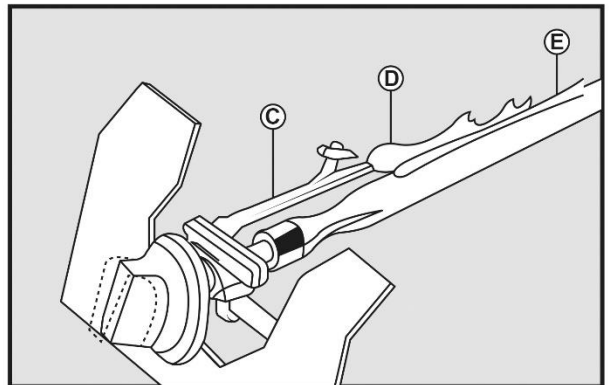
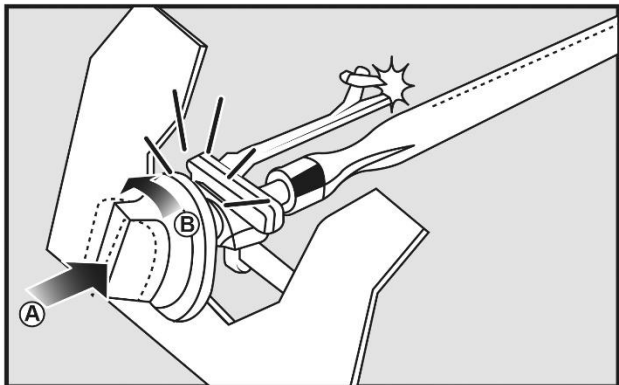

WARNING : If the burner still does not light, turn the burner control knob to "OFF" and wait 5 minutes to let the gas clear before lighting again.

WARNING: If the burner goes out while the grill is in operation, turn the control dial to the "OFF" position. Open the lid and wait 5 minutes before attempting to relight the BBQ.

FOOD SAFETY

- Thoroughly defrost frozen meat and poultry in the refrigerator before cooking. Keep raw meat and poultry separate from cooked foods.
- Always wash hands after handling raw meat and poultry, before handling any ready to eat foods.
- Wipe and disinfect surfaces that have been in contact with raw meat and poultry.
- When barbecuing meat and poultry, make sure the barbecue is extremely hot. Place the larger, thicker portions furthest away from the most intense heat to ensure thorough cooking without burning and turn regularly.
- Use separate utensils for handling raw meat/poultry and cooked food on the barbecue, or wash them thoroughly between uses.
- To check whether meat, particularly poultry, is cooked, pierce the flesh with a skewer or fork; the juices should run clear. Ensure the product is piping hot throughout.

TIPS FOR USE

Preheating your gas BBQ before cooking food is important.

Follow the Lighting your BBQ instructions, then turn control dial to the “HIGH” position and close the lid to preheat your BBQ.

This will take 10 to 15 minutes depending on conditions such as air temperature and wind. After preheating, you can adjust the control dial as desired.

Food can be barbecued with the lid up or down. However, cooking with the lid down will ensure more even cooking. For every 5 minutes that the lid is down, open the lid for 1 minute to release heat.

To save energy, we recommend:

- Minimising the time the lid is open
- Turn off the BBQ and gas supply as soon as cooking is completed
- Do not preheat the grill for longer than 10 to 15 minutes
- Do not use a higher heat setting than is required.

STORAGE

Your gas cylinder must be stored outdoors in a well ventilated area and must be disconnected from your gas BBQ when not being used.

Ensure that you are outdoors and away from any sources of ignition before attempting to disconnect the gas cylinder from your BBQ.

After use and once the BBQ has cooled down we recommend that your BBQ is stored indoors, or in a garage or shed.

When using your BBQ after a period of storage, always check for gas leaks and any obstructions in the burner before using.

CLEANING INSTRUCTIONS

WARNING: Ensure the appliance is cold before cleaning.

- Empty the grease tray after each use and wash in warm soapy water.
- Grill trays should be cleaned by soaking and washing in warm soapy water.
- The interior surfaces of the grill housing cover should also be washed with warm, soapy water. Use a wire brush, steel wool or a scouring pad to remove stubborn spots.
- Periodically check the burner to see that it is free from insects and spiders which may clog the gas system and deflect the gas flow.
- Ensure the venturi pipes (A) on the burner (B) are clean, and ensure there are no obstructions. We recommend that you use a pipe cleaner to clean the venturi pipe area.
- Any modifications of this appliance may be dangerous and are not permitted.

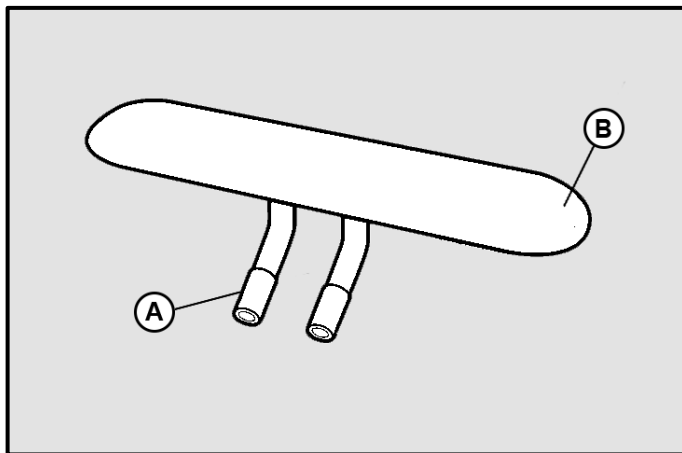

TROUBLESHOOTING

PROBLEM	POSSIBLE CAUSE	PREVENTION/ SOLUTION
Gas leaking from cracked/cut/burned hose	Damaged hose	Turn off gas at LP tank, if hose is cut or cracked, replace hose.
Gas leaking from LP tank	Mechanical failure due to resting or mishandling	Turn off LP tank valve and replace.
Gas leaking from LP tank valve	Failure of tank valve from mishandling or mechanical failure	Turn off LP tank valve and replace.
Gas leaking between LP tank and regulator connection	Improper installation, connection not tight, failure of rubber seal	Turn off LP tank valve, remove regulator from cylinder and visually inspect rubber seal for damage.
Fire coming through control panel	Fire in burner tube section of burner due to partial blockage	Turn off control knobs and LP tank valve. After fire is out and grill is cold, remove burner and inspect for spider nests or rust.
Grease fire or continuous excessive flames above cooking surface	Too much grease buildup in burner area	Turn off LP Tank. Leave lid open to allow flames to die down. After cooling, clean food particles and excess grease from inside firebox area, grease cup/pan/tray, and other surfaces
Burner will not light using ignitor	Gas issues 1. Burner not engaged with control valve 2. Obstruction in burner 3. No gas flow 4. Coupling nut ad LP tank valve not fully connected.	1. Make sure valve are positioned inside of burner tubes. 2. Ensure burner tube is not obstructed with spider webs or other material, see cleaning section of use and care 3. Make sure LP tank is not empty. If LP tank is not empty, refer to “sudden drop in gas flow.” 4. Turn the coupling nut approximately one-half to three-quarters

TROUBLESHOOTING

PROBLEM	POSSIBLE CAUSE	PREVENTION/ SOLUTION
Burner will not light using ignitor	Electrical issues: 1. Electrode cracked or broken;" sparks at crack." 2. Electrode tip not in proper position 3. Wire and/or electrode covered with cooking residue. 4. Wires are loose or disconnected 5. Wires are shorting (sparking) between ignitor and electrode. 6. push button sticks at bottom sparking between ignitor and electrode	1. Replace electrode. 2. Tip of electrode should be pointing toward port hole in burner. The distance should be 1/8" to 3/16". Adjust if necessary. 3. Clean wire and or electrode with rubbing alcohol and clean swab. 4. Reconnect wires or replace electrode/wire assembly. 5. Replace ignitor wire 6. Replace ignitor 7. Inspect wire insulation and proper connection. Replace wires if insulation is broken.
Sudden drop in gas flow or low flame	1. Grease buildup. 2. Excessive fat in meat. 3. Excessive cooking temperature	1. Clean burners and inside of grill/ firebox 2. Trim fat from meat before grilling.
Flames blow out	1. High or gusting winds. 2. Low on LP gas. 3. Excess flow valve tripped.	1. Turn front of grill to face away from wind or increase flame height. 2. Refill LP tank. 3. Refer to "sudden drop in gas flow" above.
Persistent grease fire	Grease trapped by food buildup around burner system.	Turn knobs to OFF. Turn gas off at LP tank. Leave lid in open position and let fire burn out. After grill cools, remove and clean all parts.
Flashback... (fire in burner tube(s))	Burner and burner tubes are blocked	Turn knobs to OFF. clean burner and/or burner tubes. See burner cleaning section of use and care manual
Flare-up	1. Grease buildup. 2. Excessive fat in meat. 3. Excessive cooking temperature	1. Clean burners and inside of grill/ firebox 2. Trim fat from meat before grilling. 3. Adjust (lower) temperature

GUARANTEE AND CUSTOMER SERVICES

This product is guaranteed for **12 months** from the date of the original purchase. If any defect arises due to faulty materials or workmanship, the faulty product must be returned to the place of purchase. Refund or replacement is at the discretion of the retailer.

The following conditions apply:

- The product must be returned to the retailer with the original proof of purchase.
- The product must be installed and used in accordance with the instructions contained in this instruction guide and any other instructions for use which are supplied.
- It must be used for domestic purposes only and for its intended use.
- This warranty does not cover wear and tear, damage, misuse or consumable parts.

This does not affect your statutory rights.

Customer Services & Spare Parts:

Region	Contact
UK & Northern Ireland	0345 209 7461
Ireland	1 800 938982
Rest of Europe	europa@productcaregroup.com

NOTES

NOTES

GEORGE FOREMAN®

3 BURNER GAS BBQ

GFGBBQ3BW

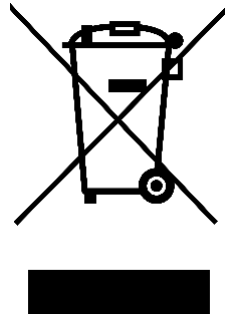

Made by . Product Care Trading Ltd, Unit 1,
Green Bank Business Park, Swan Lane,
Hindley Green, Wigan, WN2 4AY, United
Kingdom / Product Care (Ireland) Ltd, Unit 3D
North Point House, North Point Business Park,
New Mallow Road, Cork, T23 AT2P, Ireland.

George Foreman is the registered trademark
of Spectrum Brands (U.K.) Ltd.

Revision 4.6