











# ASSEMBLY INSTRUCTIONS

NO	Parts list		QTY
1	table top		1pcs
2	shelf		1pcs
3	Left legs		2pcs
4	Right legs		2pcs

NO	Hardware		QTY
A		Ø 1/4"*1-1/4" Bolt	8pcs
B		Ø 1/4"*1/2" Bolt	16pcs
C		Ø1/4"*16mm Flat washer	24pcs
D		Ø1/4" Spring washer	8pcs
E		Ø1/4" All-Wrench	1pcs
F		Bracket	4pcs

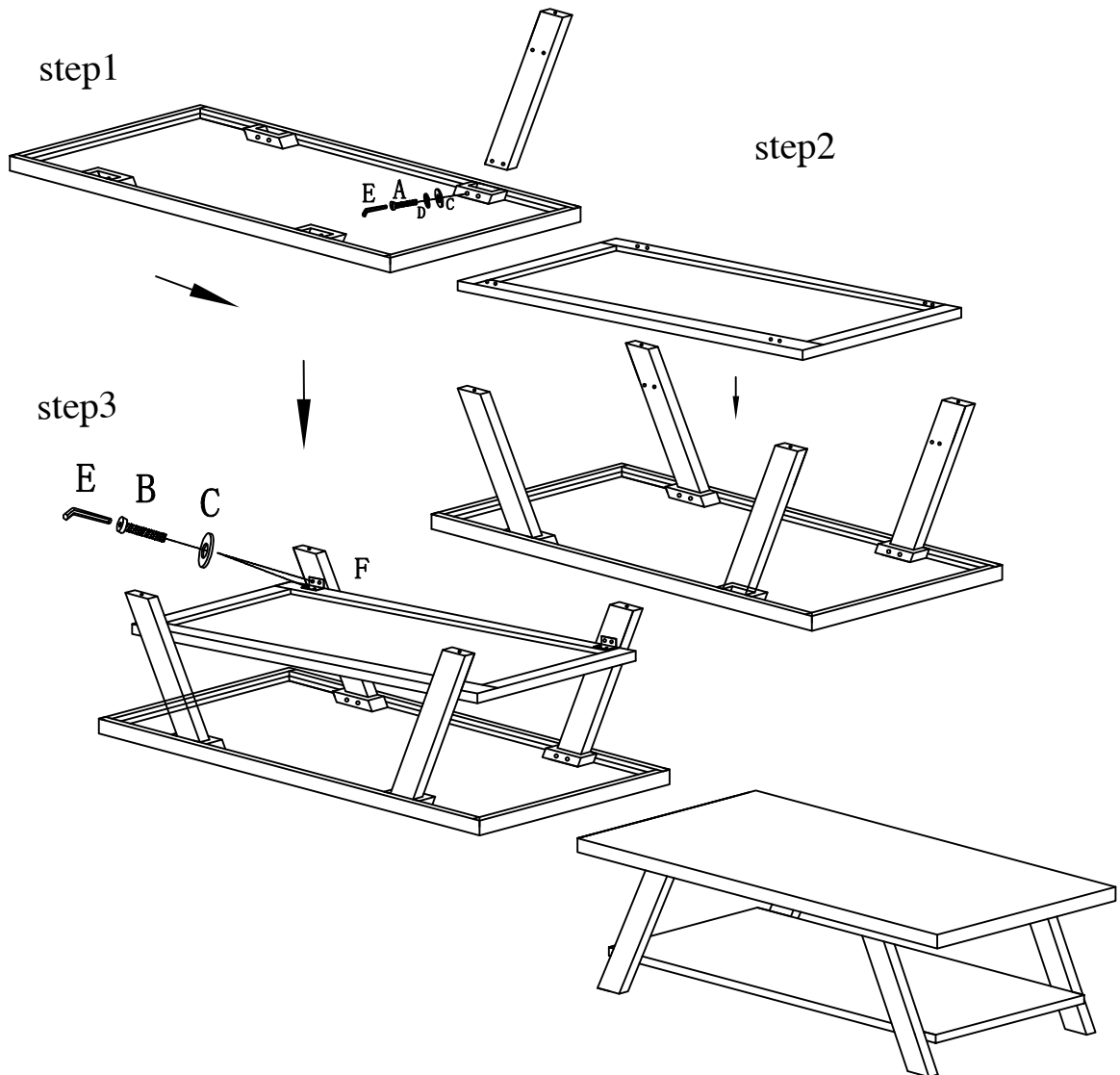

**Do not tighten screws until completely assembled**