

50034/50011-011/012/021/022/313/323 FB ASSEMBLY INSTRUCTION

Thank you for purchasing this quality product. Be sure to check all packing material carefully for small parts which may have come loose inside the carton during shipment. Separate, identify and count all parts and hardware. Compare with the parts list to be sure all parts are present.

IMPORTANT : PLEASE READ INSTRUCTION BEFORE STARTING THE ASSEMBLY.

"DO NOT TIGHTEN SCREWS UNTIL COMPLETELY ASSEMBLED"

"DO NOT OVERTIGHT ANY HARDWARE"

WARNING : SMALL PARTS AND HARDWARE NOT FOR CHILDREN UNDER 3 YEARS. ADULT ASSEMBLY REQUIRED.

TABLE OF CONTENTS

HARDWARES LIST

PAGE 2 - 4

PARTS LIST

PAGE 5 - 7

PARTS' LOCATION

PAGE 8

ASSEMBLY STEPS

PAGE 9 - 21

ASSEMBLY COMPLETED

PAGE 21

ASSEMBLY TOOLS REQUIRED

1. Screwdriver (not provide)

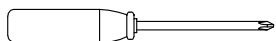

2. Hammer (not provide)

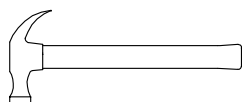

3. Rubber Hammer (not provide)

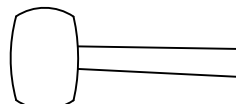



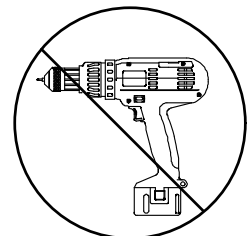



Skip the power drill this time.

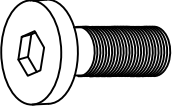
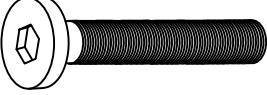

50034/50011-011/012/021/022/313/323 FB ASSEMBLY INSTRUCTION

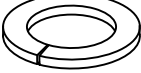
HARDWARES LIST (SECTION A)

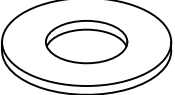

ITEM	DESCRIPTION	DRAWING	QTY
A	MINIFIX CAM LOCK		16 PCS
B	MINIFIX CAM BOLT		16 PCS
C	WOOD DOWEL (M8 x 30MM)		16 PCS
D	JCBB SCREW M8 x 16MM		4 PCS
F	JCBC SCREW M6 x 45MM		9 PCS
H	SPRING WASHER M6 x 13MM (SMALL)		9 PCS
I	SPRING WASHER M8 x 14MM (BIG)		4 PCS
J	FLAT WASHER M6 x 19MM (SMALL)		9 PCS
K	FLAT WASHER M8 x 22MM (BIG)		4 PCS

50034/50011-011/012/021/022/313/323 FB ASSEMBLY INSTRUCTION

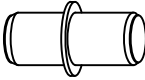
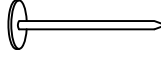
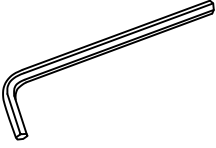
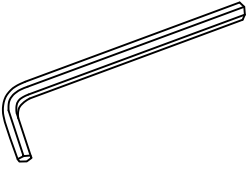
HARDWARES LIST (SECTION A)

ITEM	DESCRIPTION	DRAWING	QTY
N	SHELF SUPPORT (M5 x 16mm)		12 PCS
R	6/8" NAIL		28 PCS
T	M4 ALLEN KEY (65MM)		1 PC
U	M5 ALLEN KEY (65MM)		1 PC

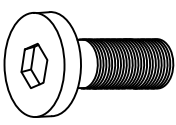
HARDWARES LIST (SECTION C)

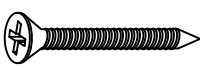
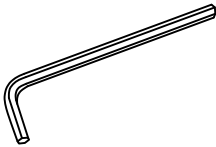

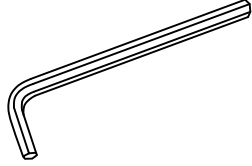

ITEM	DESCRIPTION	DRAWING	QTY
D	JCBB SCREW M8 x 16MM		8 PCS
G	JCBC SCREW M6 x 50MM		4 PCS
M	CSK C/B SCREW (M4 x 32MM)		8 PCS
T	M4 ALLEN KEY (65MM)		1 PC

50034/50011-011/012/021/022/313/323 FB ASSEMBLY INSTRUCTION

HARDWARES LIST (SECTION C)



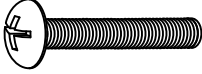
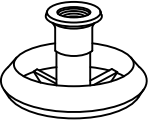
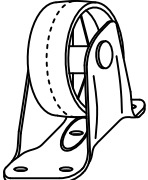

ITEM	DESCRIPTION	DRAWING	QTY
U	M5 ALLEN KEY (65MM)		1 PC

HARDWARES LIST (SECTION D)

ITEM	DESCRIPTION	DRAWING	QTY
A	MINIFIX CAM LOCK		16 PCS
B	MINIFIX CAM BOLT		16 PCS
C	WOOD DOWEL (M8 x 30MM)		16 PCS
L	CSK C/B SCREW (M4 x 16MM)		32 PCS
P	TRUSS M-SCREW (20MM)		4 PCS
Q	HANDLE		4 PCS
S	CASTER		8 PCS

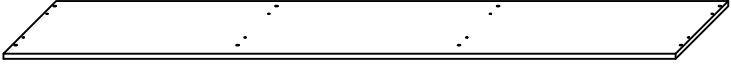
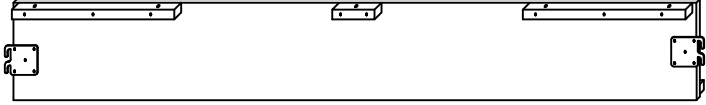
50034/50011-011/012/021/022/313/323 FB ASSEMBLY INSTRUCTION

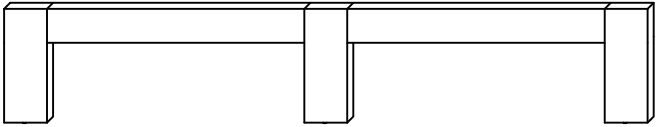
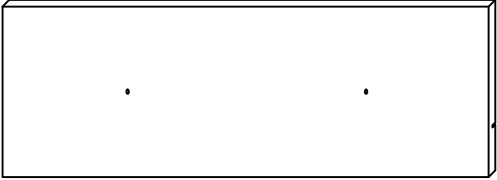
PARTS LIST (BOX 1)



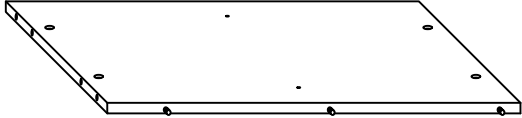
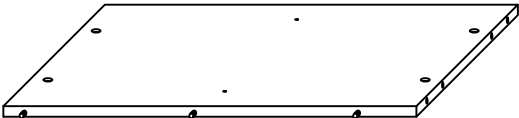

ITEM	DESCRIPTION	DRAWING	QTY
1	HEADBOARD BOX TOP PANEL		1 PC
6	HEADBOARD BOX BOTTOM PANEL		1 PC
9	HEADBOARD MIDDLE SUPPORT PANEL		1 PC
10	BACK PANEL		1 PC
11	FOOTBOARD		1 PC
16	DRAWER HEAD		2 PCS
22	TOP FRAME		1 PC

PARTS LIST (BOX 2)

ITEM	DESCRIPTION	DRAWING	QTY
2	HEADBOARD BOX LEFT PANEL (L)		1 PC
3	HEADBOARD BOX RIGHT PANEL (R)		1 PC

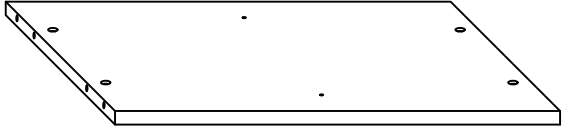
50034/50011-011/012/021/022/313/323 FB ASSEMBLY INSTRUCTION

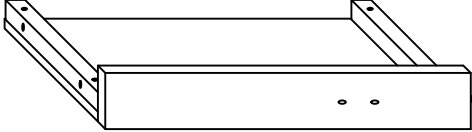
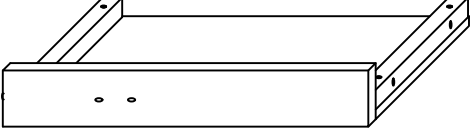
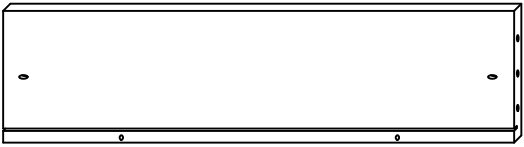
PARTS LIST (BOX 2)

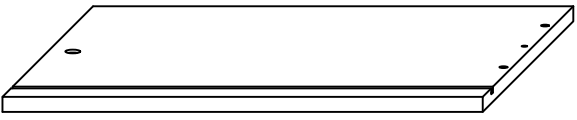
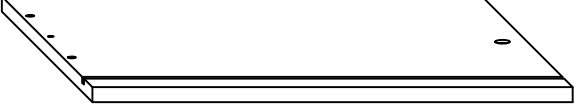
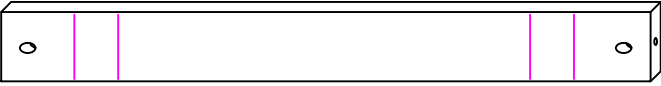

ITEM	DESCRIPTION	DRAWING	QTY
4	HEADBOARD BOX INSIDE PANEL		2 PCS
5	HEADBOARD BOX COMPARTMENT PANEL		3 PCS
7	LEFT HEADBOARD LEG (L)		1 PC
8	RIGHT HEADBOARD LEG (R)		1 PC
17	DRAWER BACK PANEL		2 PCS
18	DRAWER BOTTOM PANEL		2 PCS
19	DRAWER LEFT PANEL		2 PCS
20	DRAWER RIGHT PANEL		2 PCS
21	DRAWER BOTTOM SUPPORT RAIL		4 PCS

50034/50011-011/012/021/022/313/323 FB ASSEMBLY INSTRUCTION

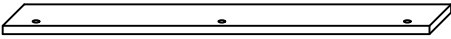
PARTS LIST (BOX 2)

ITEM	DESCRIPTION	DRAWING	QTY
23	SIDE FRAME		2 PCS

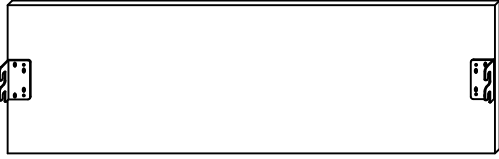
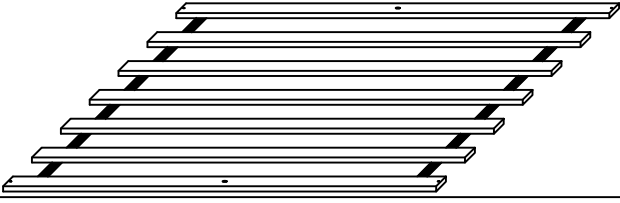
PARTS LIST (BOX 3)

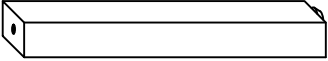
ITEM	DESCRIPTION	DRAWING	QTY
12	SIDE RAIL		2 PCS
13	SLAT (7 PCS PER SET)		2 SETS
14	SLAT SUPPORT RAIL		2 PCS
15	CENTRE SUPPORT LEG		4 PCS

PARTS ' LOCATION

BED x 1 PC

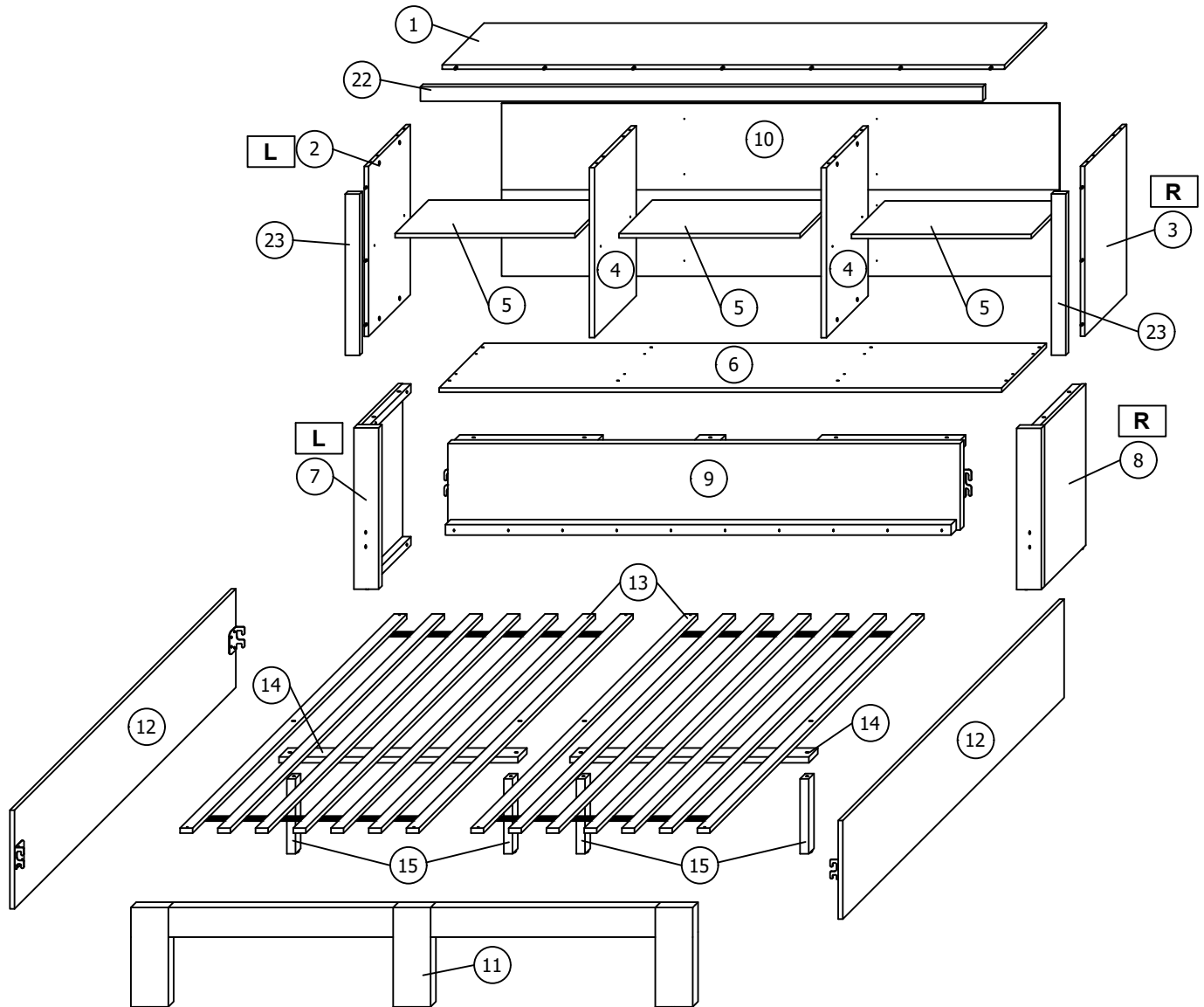

DRAWER x 2 PCS

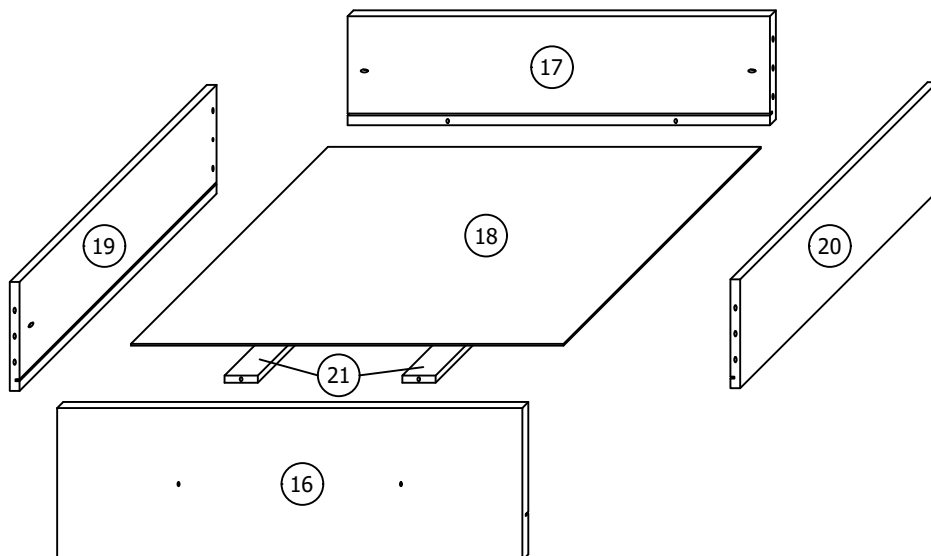

ASSEMBLY STEPS

STEP 1

Connect (2),(23) then insert 4 pieces (A) and 2 pieces (N) to the (2) as shown.

****SECTION A HARDWARE FOR ASSEMBLY STEP 1 TO STEP 11**

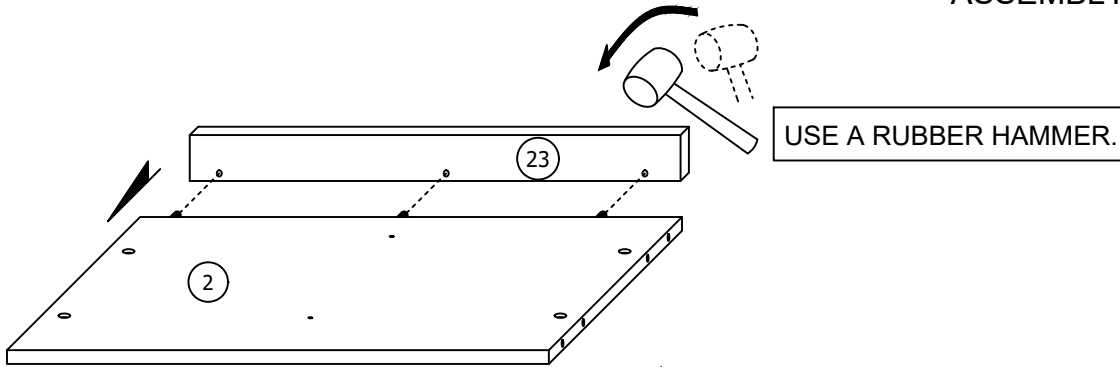

Assembled looks

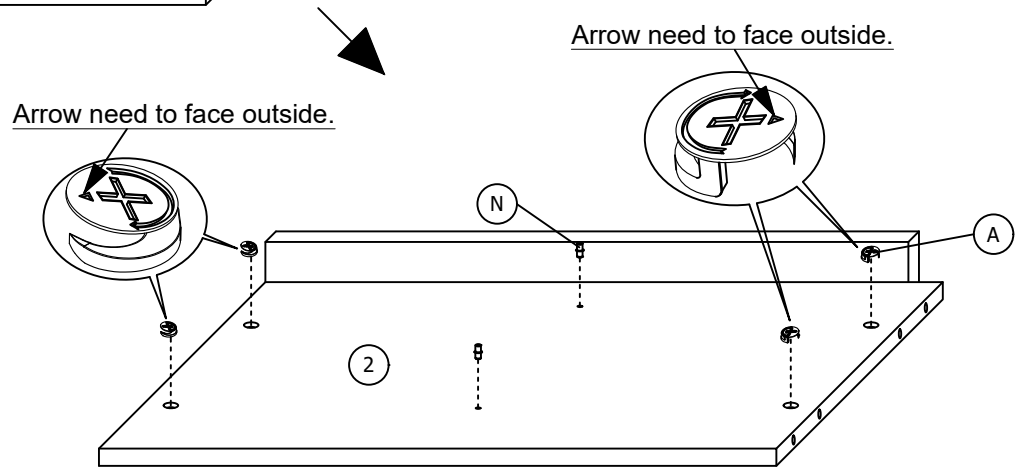
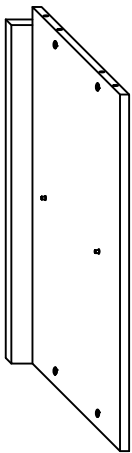

STEP 2

Connect (3),(23) then insert 4 pieces (A) and 2 pieces (N) to the (3) as shown.

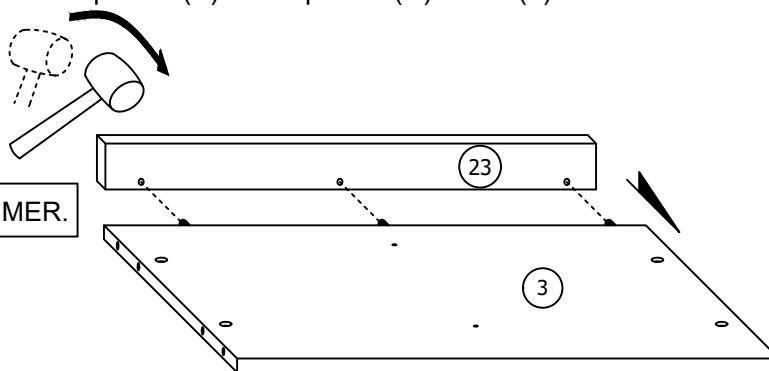

Assembled looks

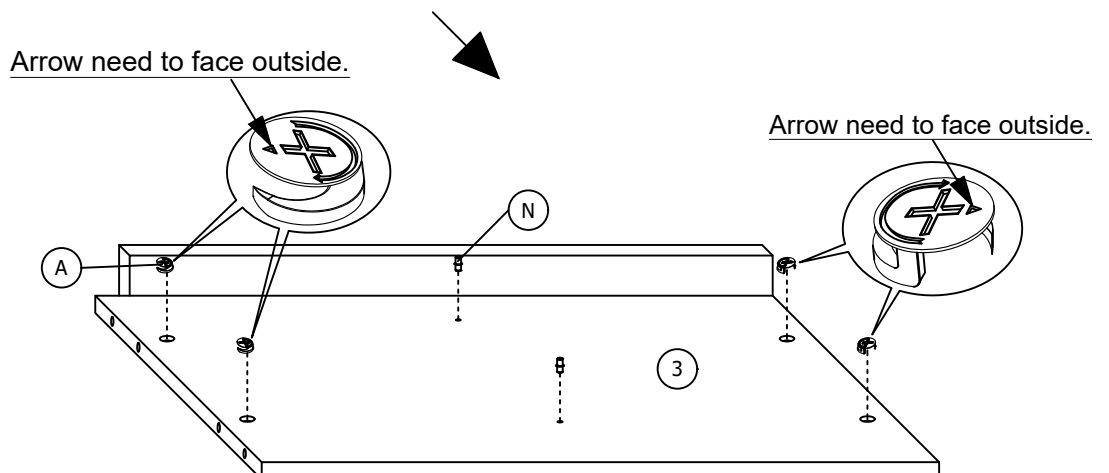
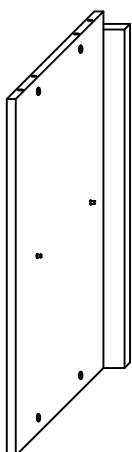

50034/50011-011/012/021/022/313/323 FB ASSEMBLY INSTRUCTION

STEP 3

Insert 4 pieces (A) and 2 pieces (N) to the one side of (4) , and 2 pieces (N) to another side as shown.

x 2

Arrow need to face outside.

Arrow need to face outside.

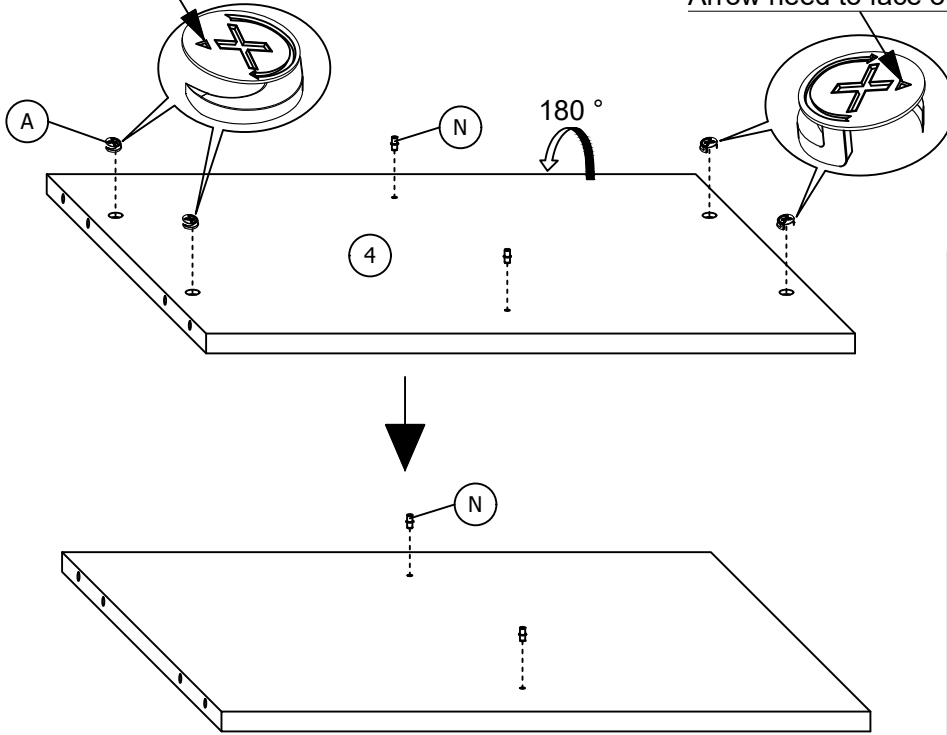

Assembled looks

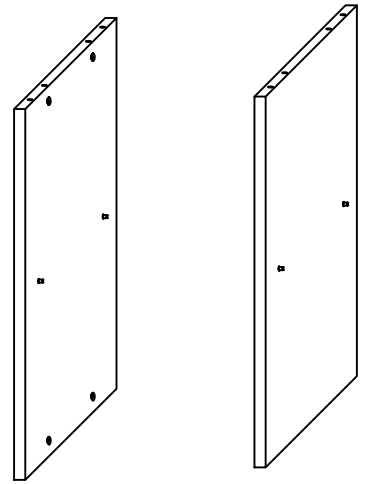

STEP 4

Insert 8 pieces (B) and (C) to the (6) as shown.

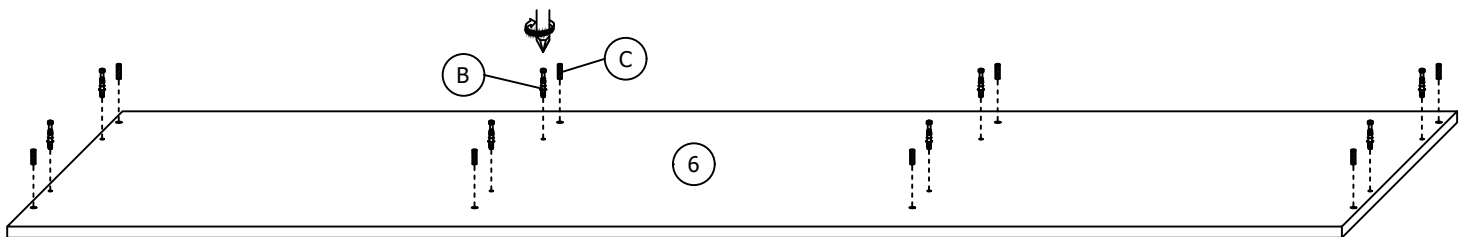

Assembled looks

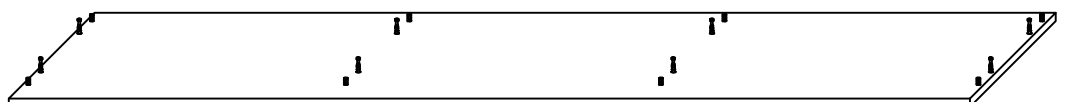

50034/50011-011/012/021/022/313/323 FB ASSEMBLY INSTRUCTION

STEP 5

Connect (1),(22) then insert 8 pieces (B) and (C) to the (1) as shown.

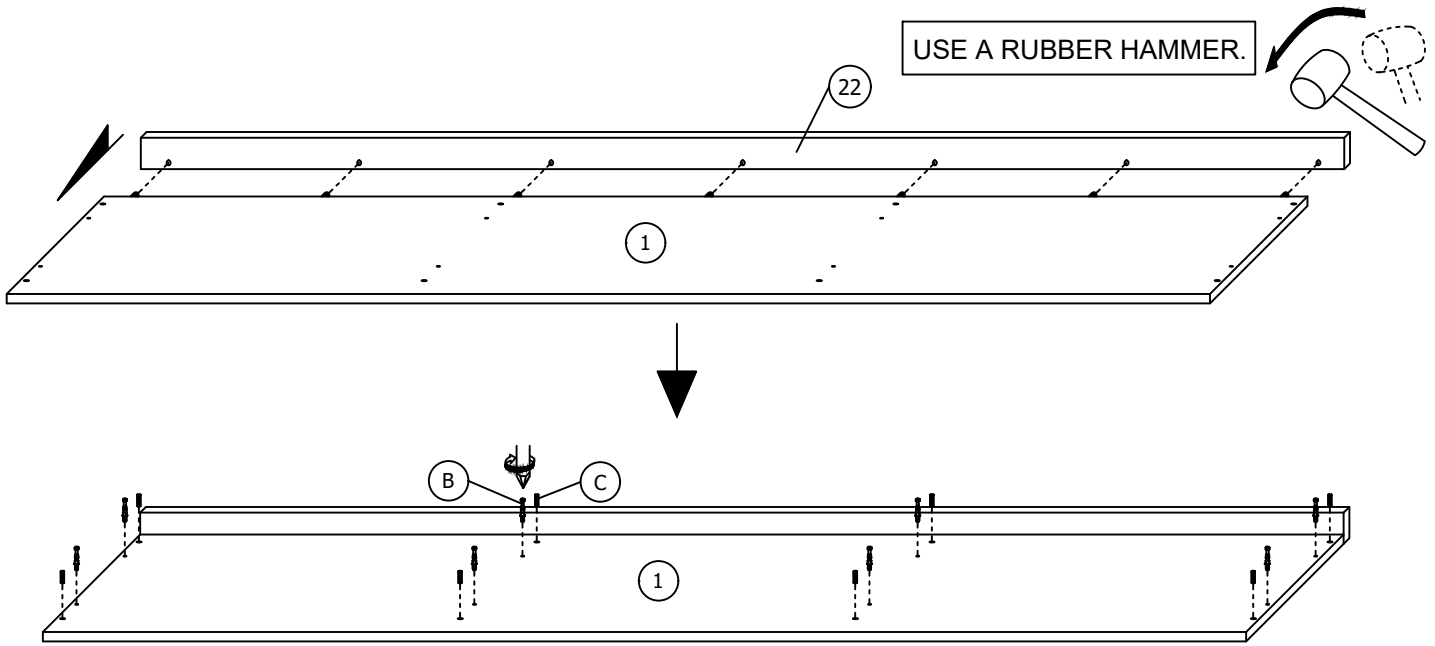

Assembled looks

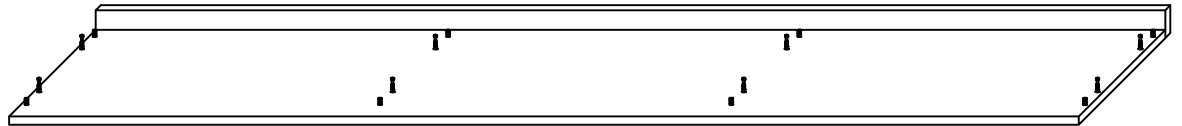

STEP 6

Combine the (2),(3) and (4) to the (6) then tighten the 8 pieces (A)-(pre insert in step 1 to 3) as shown.

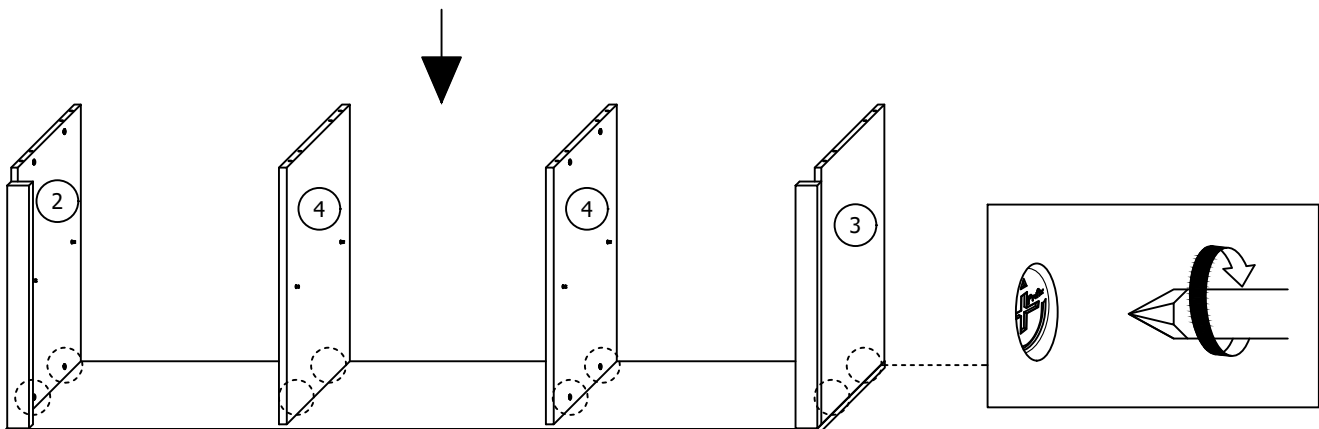
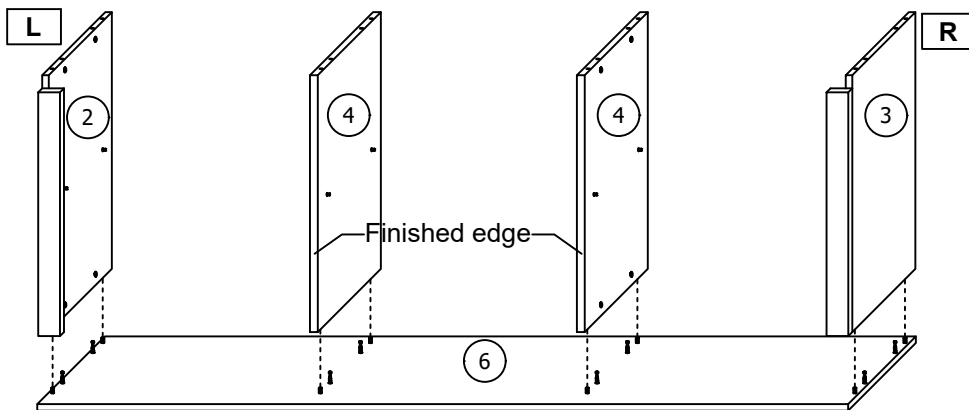

50034/50011-011/012/021/022/313/323 FB ASSEMBLY INSTRUCTION

STEP 7

Combine the (1) to the (2),(3) and (4) then tighten the another 8 pieces (A)-(pre insert in step 1 to 3) as shown.

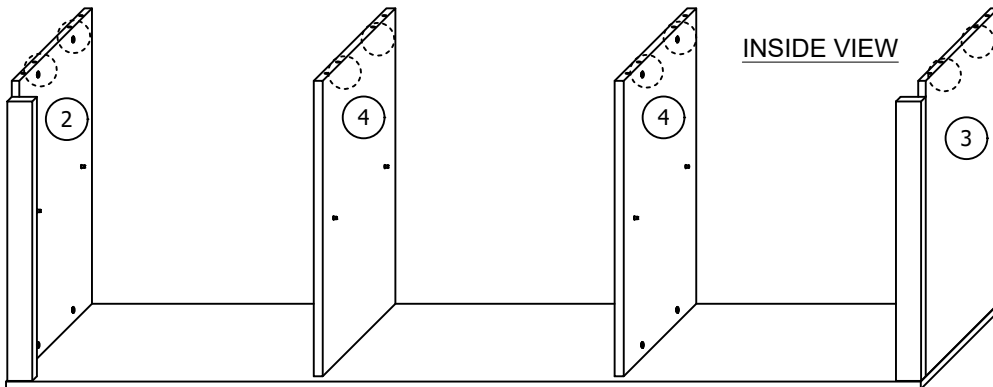
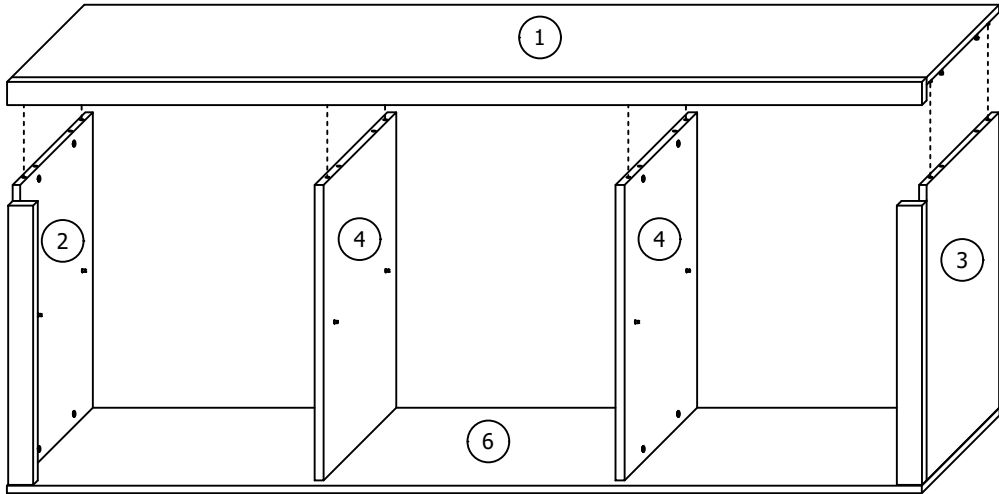

INSIDE VIEW

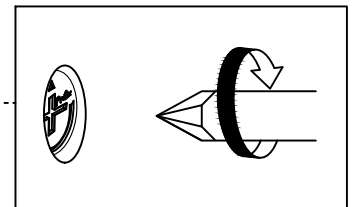

50034/50011-011/012/021/022/313/323 FB ASSEMBLY INSTRUCTION

STEP 8

Insert the 28 pieces (R) to fix the (10) as shown.

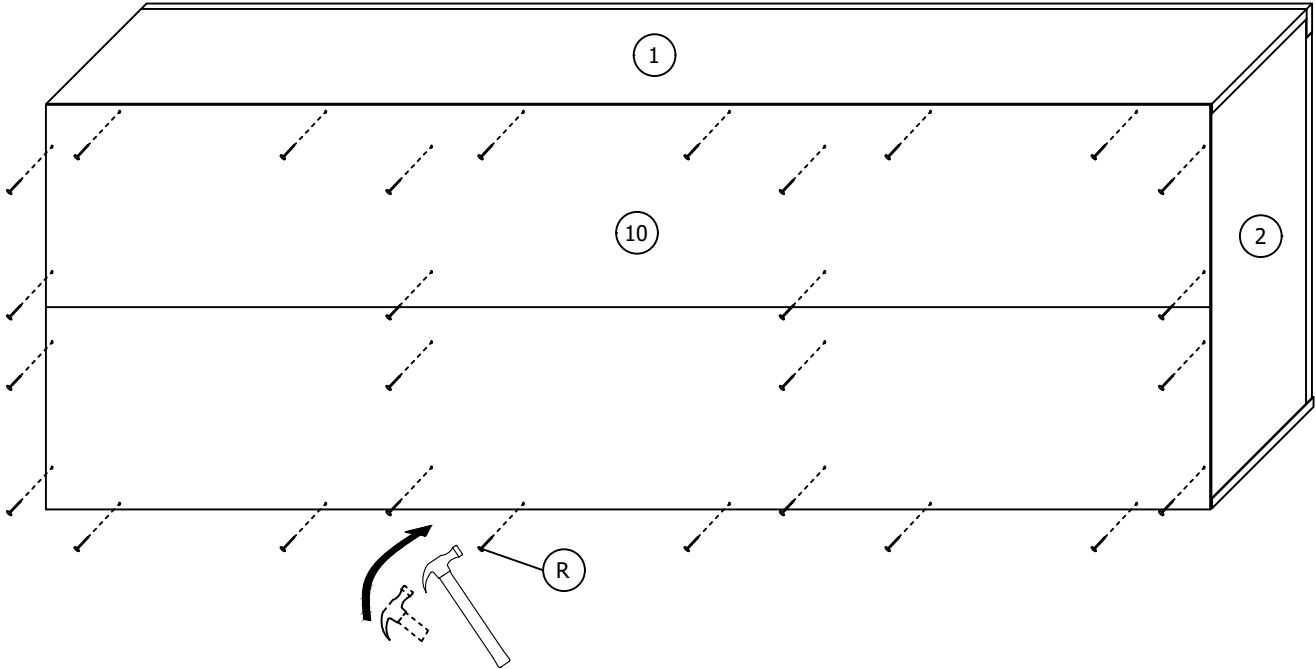

STEP 9

Insert 4 pieces (D),(I) and (K) to combine the (7),(8) and (9) as shown.

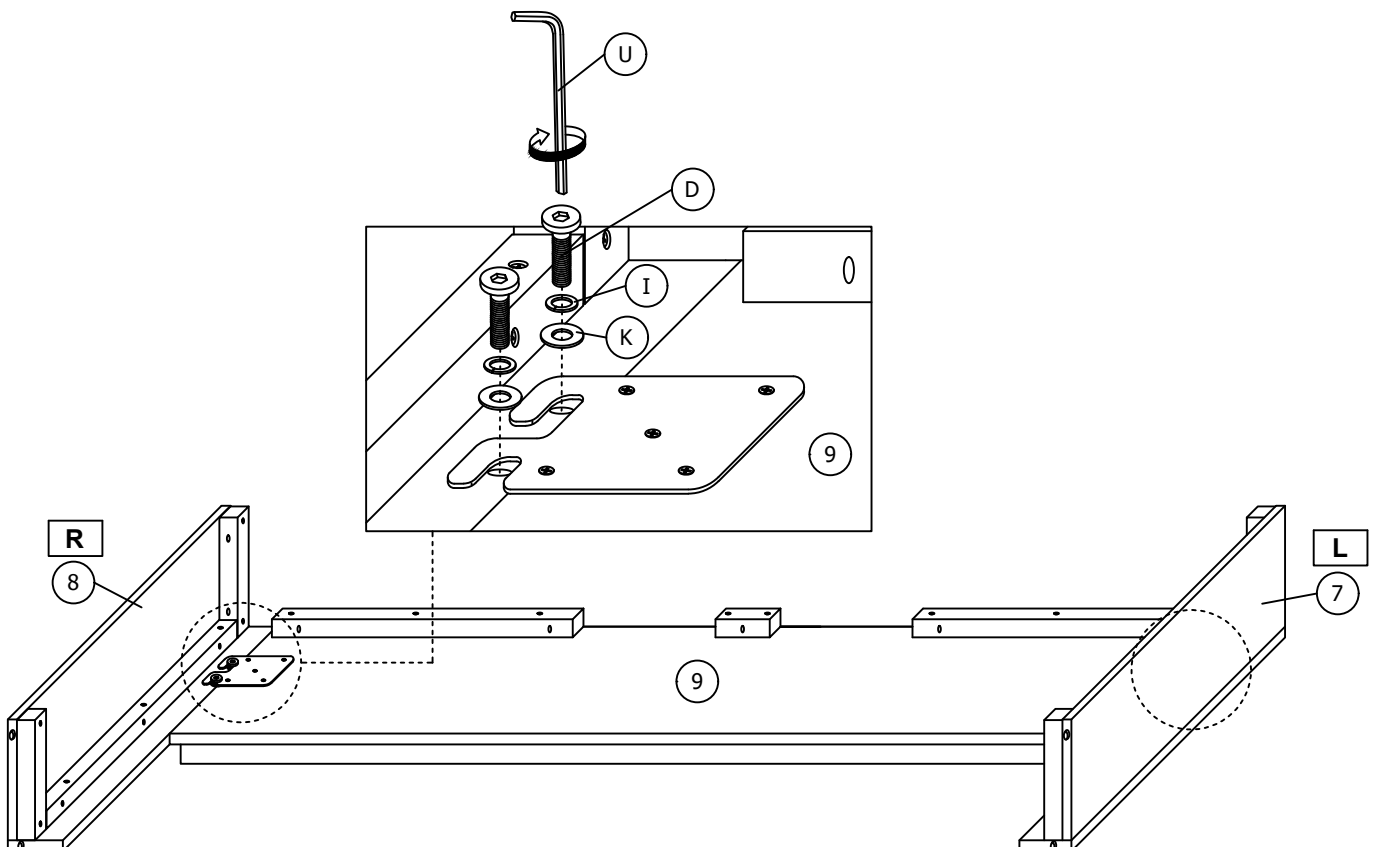

50034/50011-011/012/021/022/313/323 FB ASSEMBLY INSTRUCTION

STEP 10

Insert the 9 pieces (F),(H) and (J) to combine the (7),(8) and (9) to the (6) as shown.

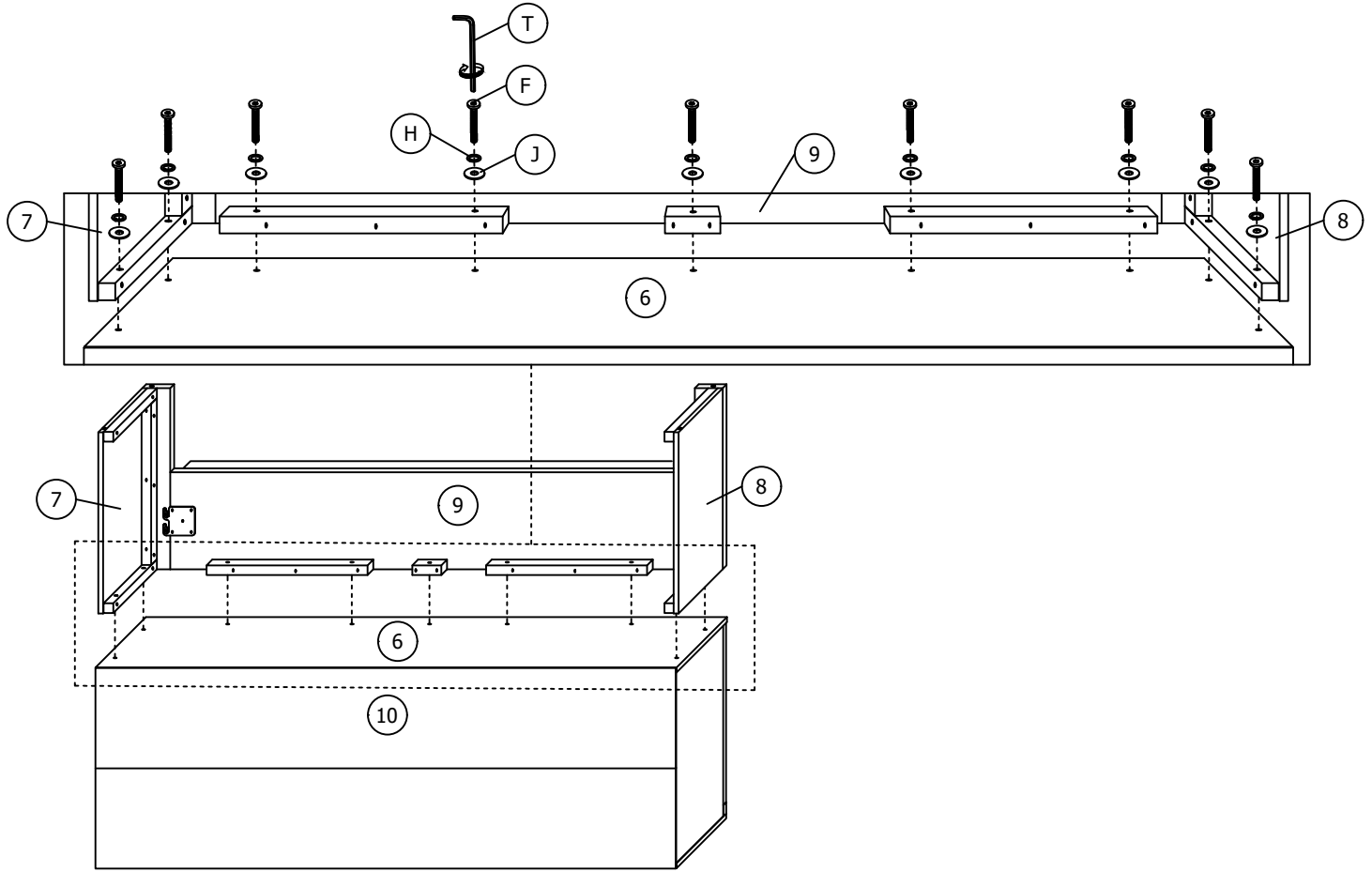

STEP 11

Put the (5) on the (N) which between (2),(3) and (4) as shown.

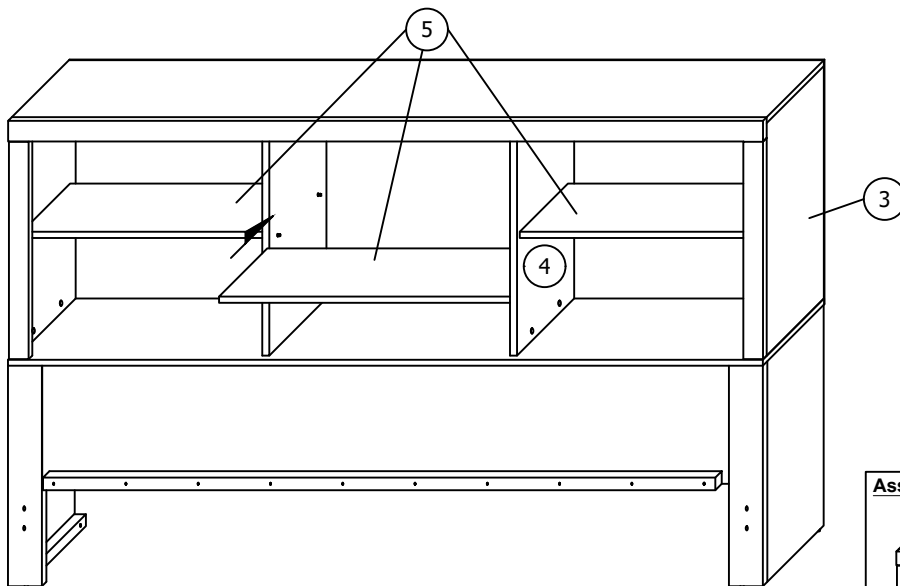

Assembled looks

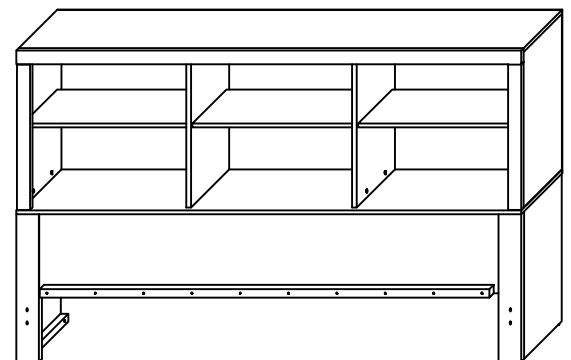

50034/50011-011/012/021/022/313/323 FB ASSEMBLY INSTRUCTION

STEP 12

Insert 4 pieces (B),(C) to the (16) as shown.

****SECTION D HARDWARE FOR ASSEMBLY STEP 12 TO STEP 21**

x 2

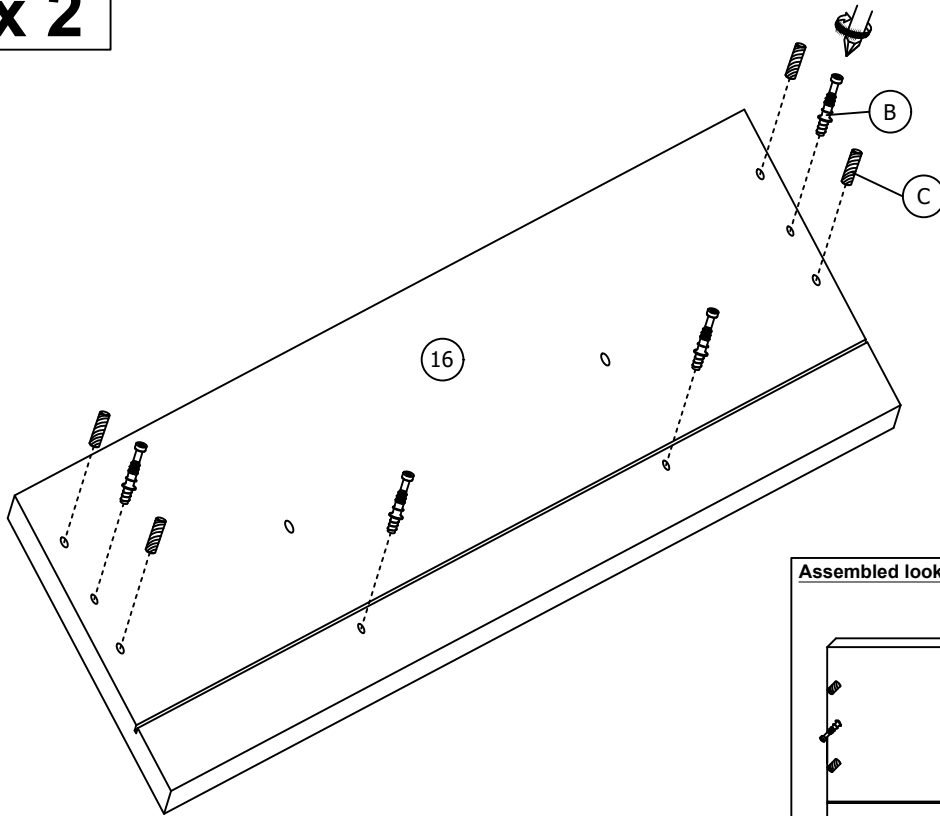

Assembled looks

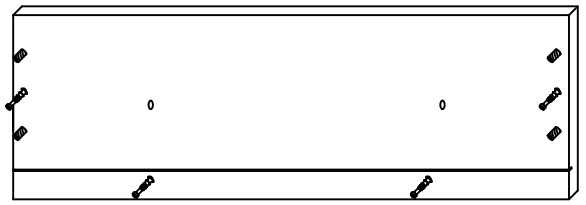

STEP 13

Insert 1 piece (A),(B) and 2 pieces (C) to (19) as shown.

x 2

Arrow need to face outside.

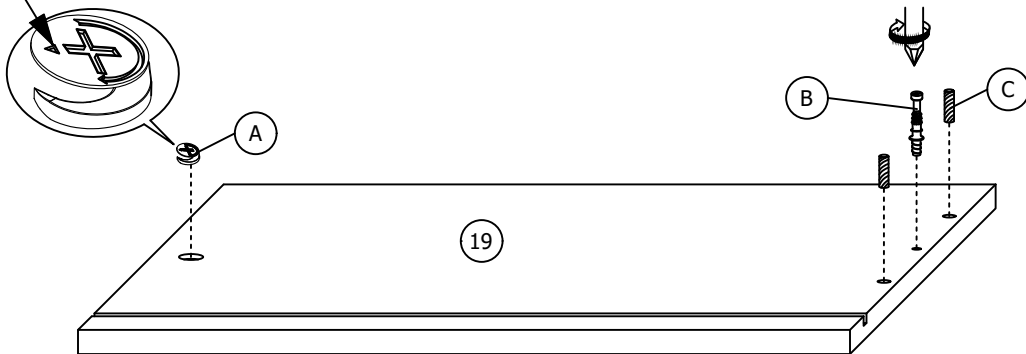

Assembled looks

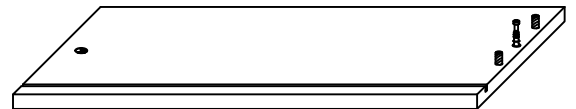

50034/50011-011/012/021/022/313/323 FB ASSEMBLY INSTRUCTION

STEP 14

Insert 1 piece (A),(B) and 2 pieces (C) to (20) as shown.

x 2

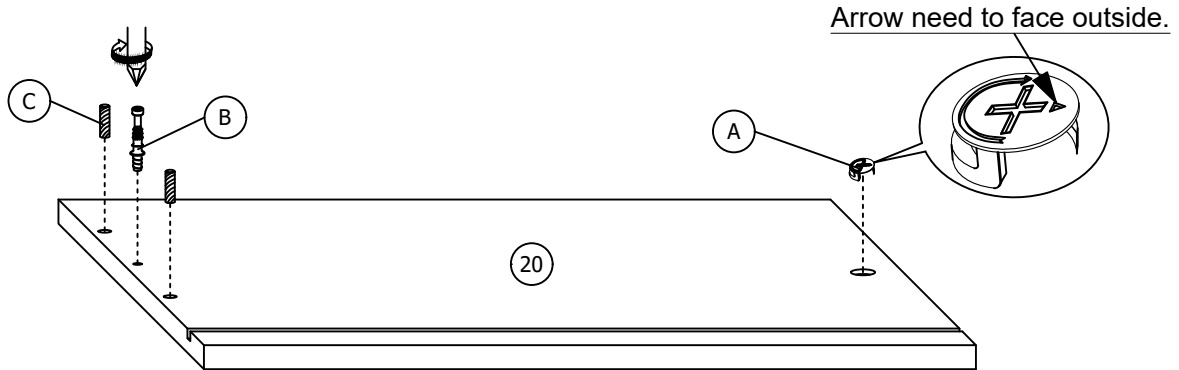

Assembled looks

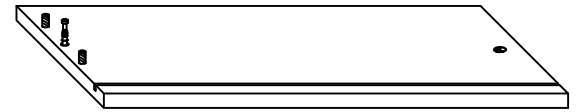

STEP 15

Insert 2 pieces (A),(B) to (17) as shown.

x 2

Arrow need to face outside.

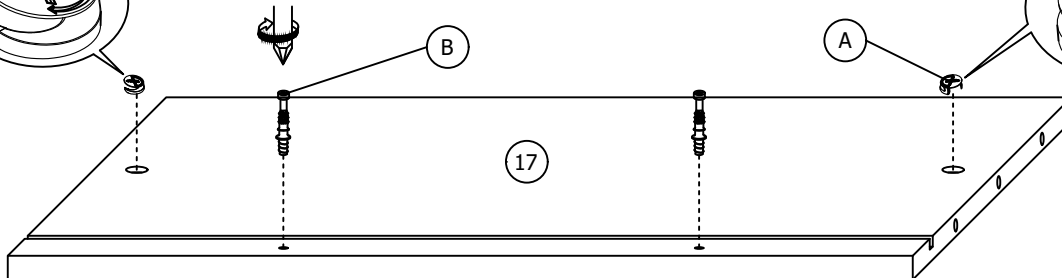

Arrow need to face outside.

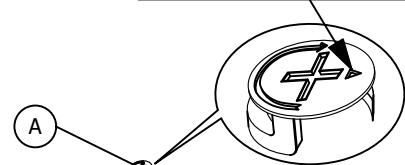

Assembled looks

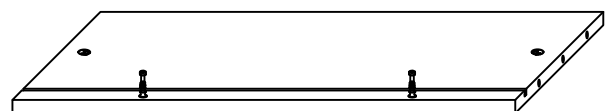

50034/50011-011/012/021/022/313/323 FB ASSEMBLY INSTRUCTION

STEP 16

Insert 2 pieces (A) to (21) as shown.

x 4

Arrow need to face outside.

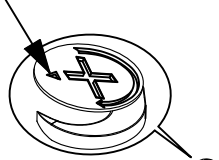

Arrow need to face outside.

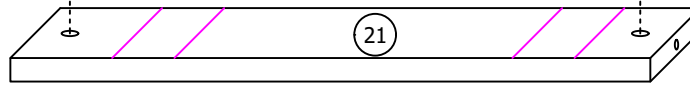

STEP 17

Combine (17),(19),(20) , then tighten the 2 pieces (A)-(pre-insert in step 15) as shown.

x 2

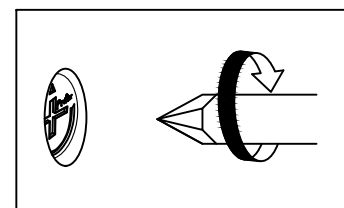
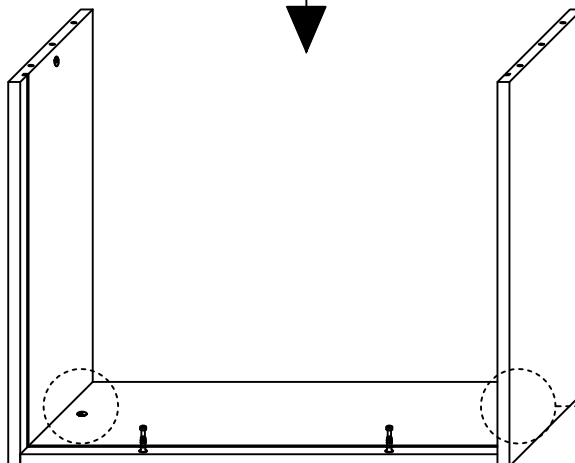
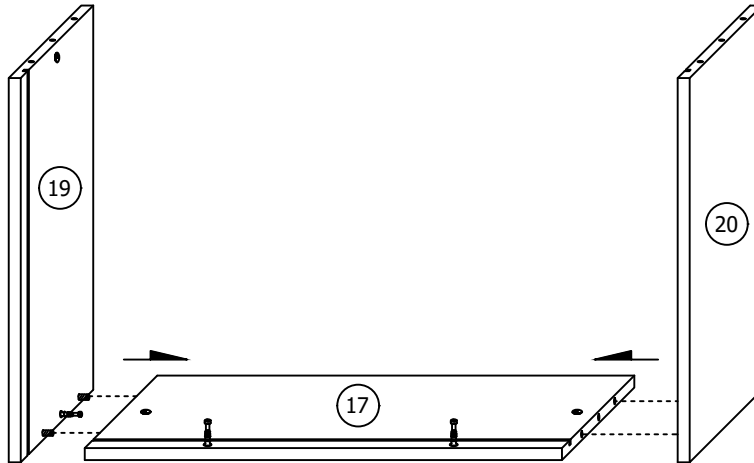

50034/50011-011/012/021/022/313/323 FB ASSEMBLY INSTRUCTION

STEP 18

Put (18) into the gap of (17),(19),(20) ,combine 2 pieces (21) to (17) then tighten the 2 pieces (A)-(pre-insert in step 16) as shown.

x 2

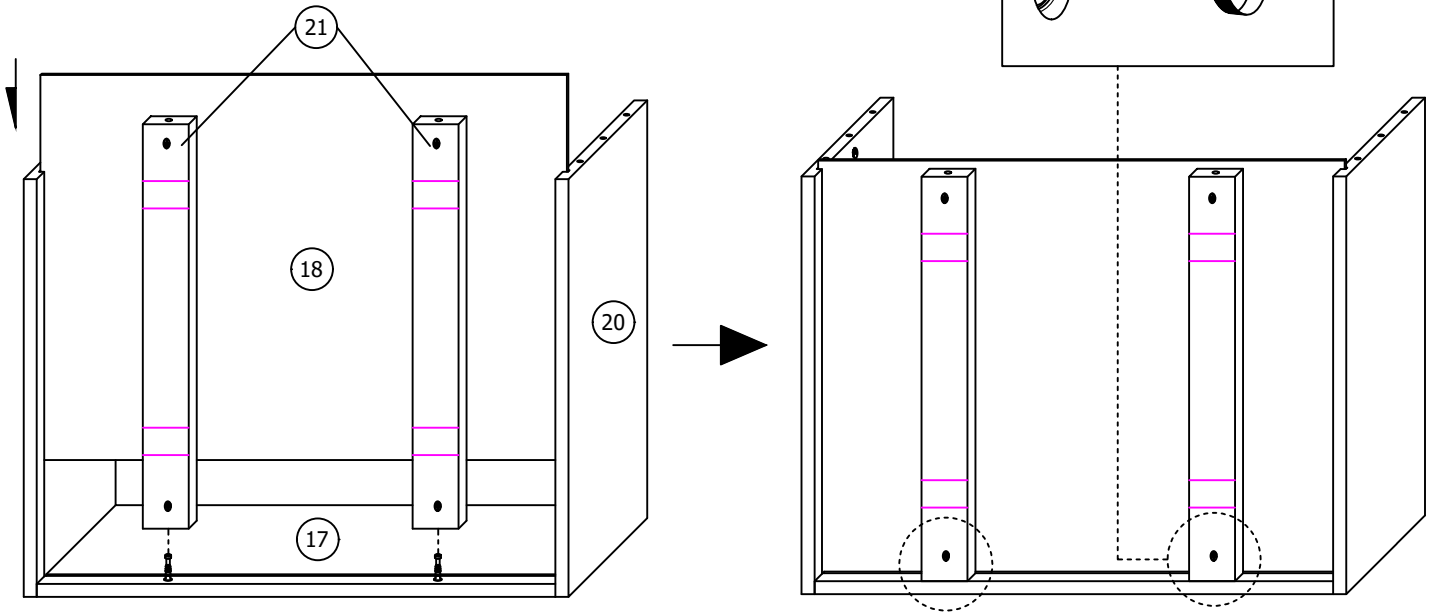

STEP 19

Combine (16) to the drawer box then tighten the 4 pieces (A)-(pre-insert in step 13,14 and 16) as shown.

x 2

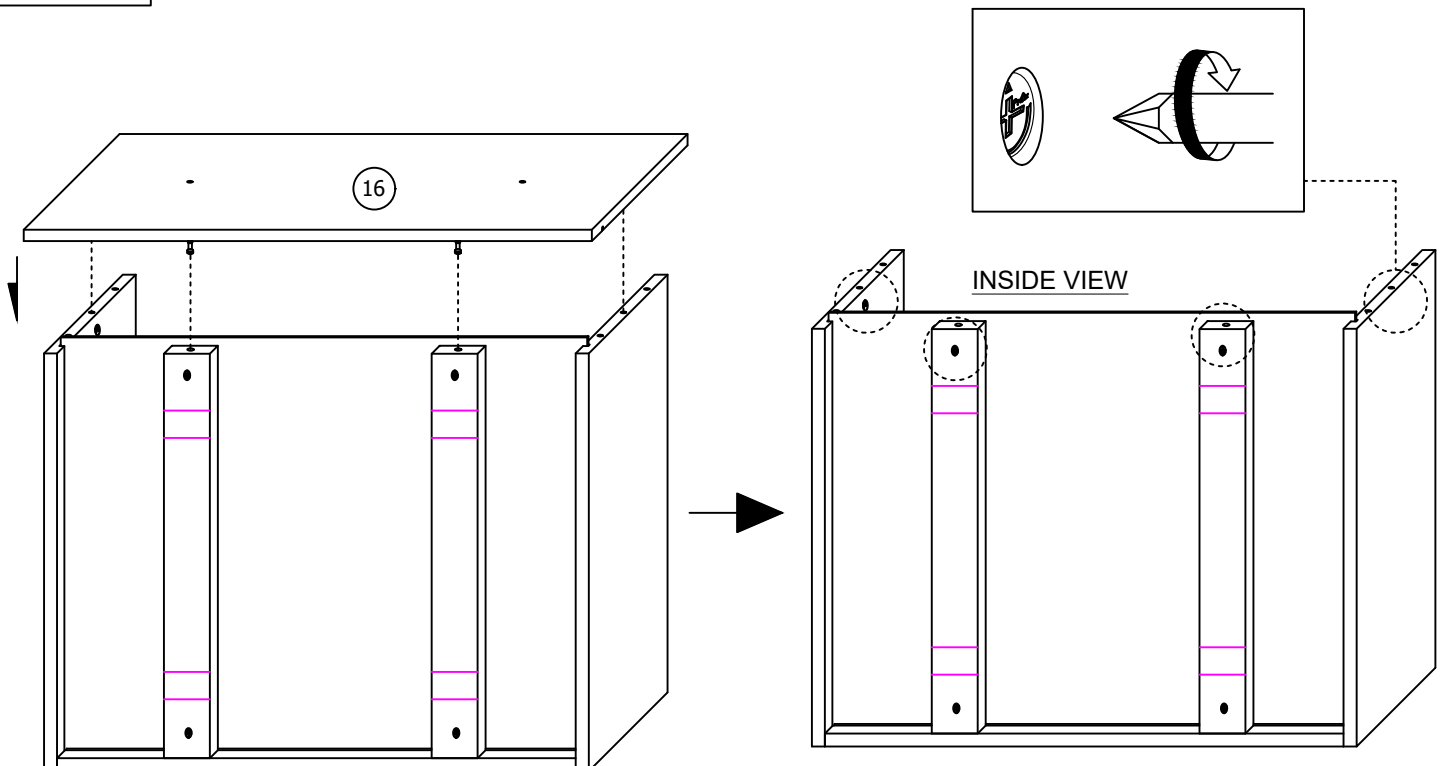

50034/50011-011/012/021/022/313/323 FB ASSEMBLY INSTRUCTION

STEP 20

Insert 16 pieces (L) to fix 4 pieces (S) to the (21) as shown.

x 2

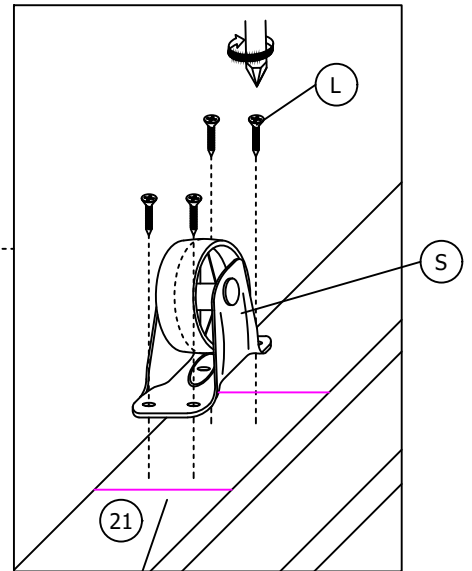
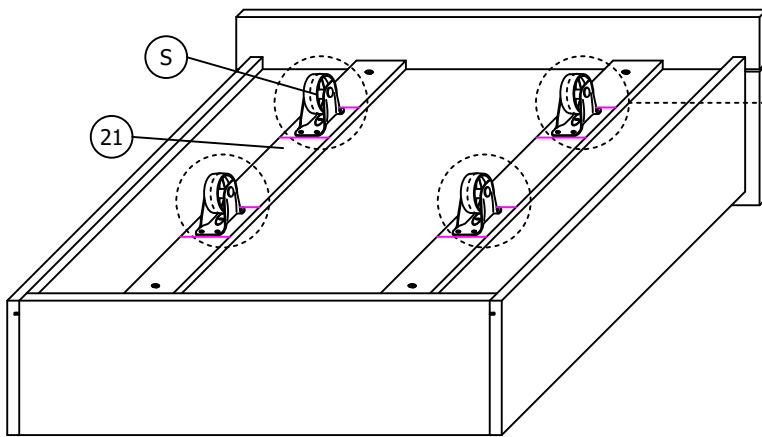

**Rotate 180 degrees after completed this step.

Place (S) in the line

STEP 21

Insert 2 pieces (P) fix the 2 pieces (Q) as shown.

x 2

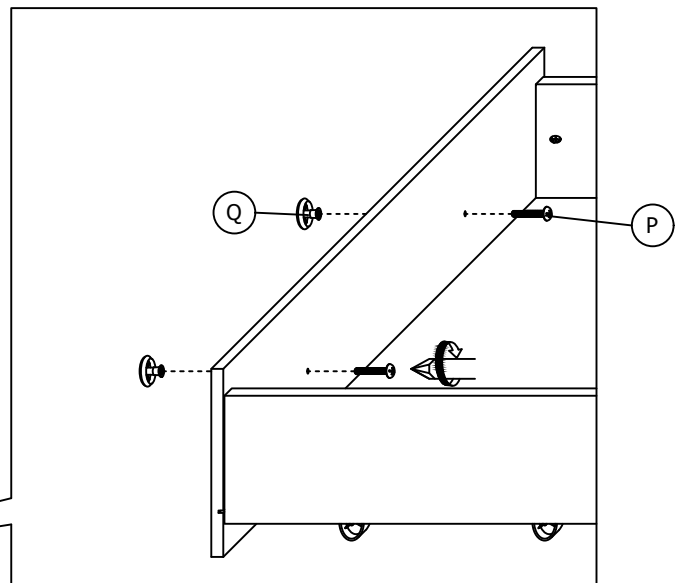
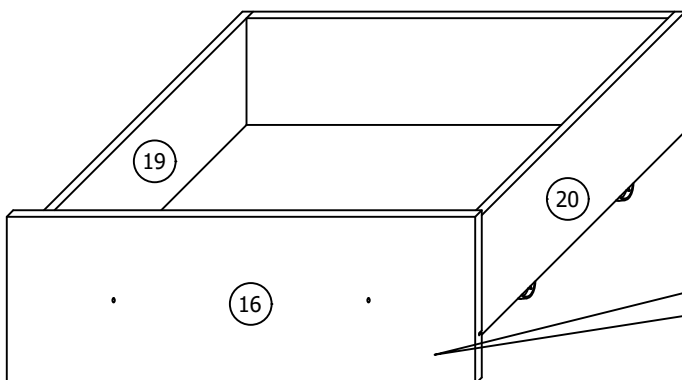

50034/50011-011/012/021/022/313/323 FB ASSEMBLY INSTRUCTION

STEP 22

Insert the 8 pieces (D) to combine the (7),(8),(11) and (12) as shown.

****SECTION C HARDWARE FOR ASSEMBLY STEP 22 TO STEP 24**

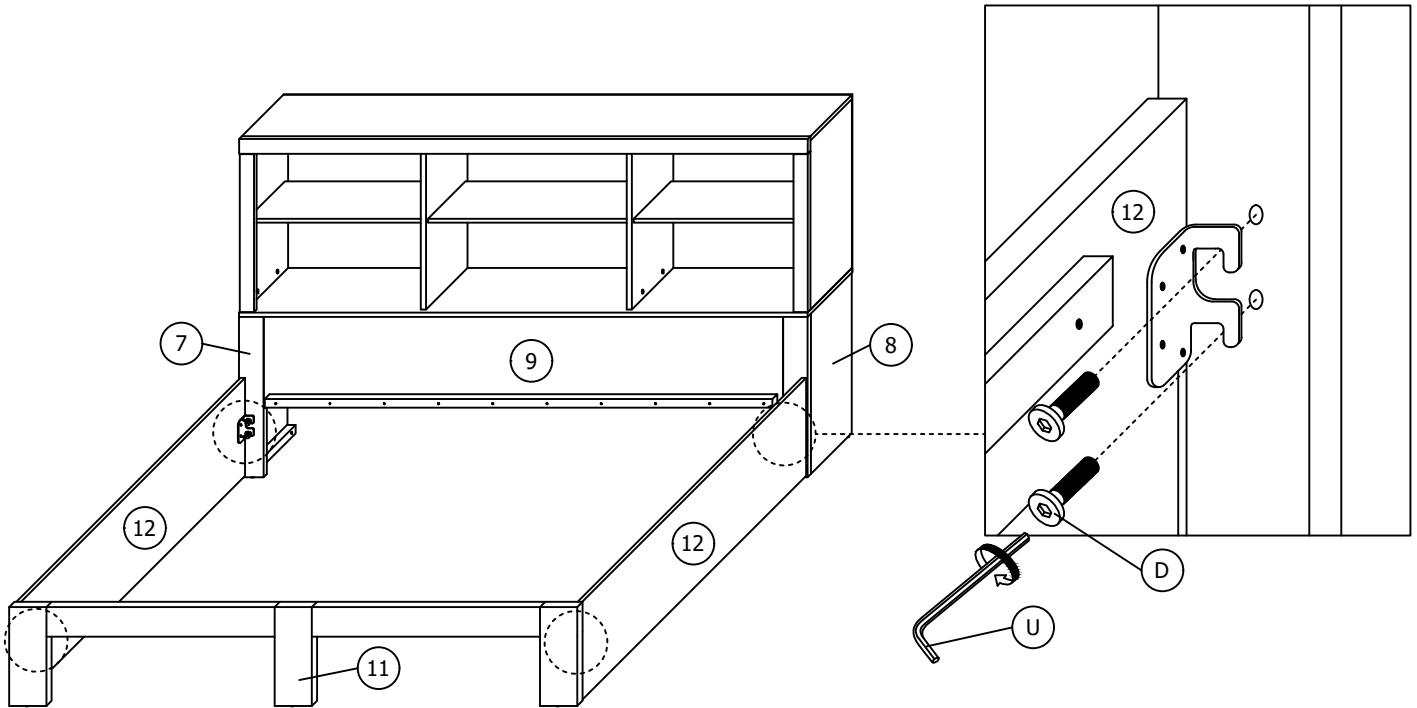

STEP 23

Insert 2 pieces (G) to combine the 1 piece (13) and (14), 2 pieces (15) as shown.

x 2

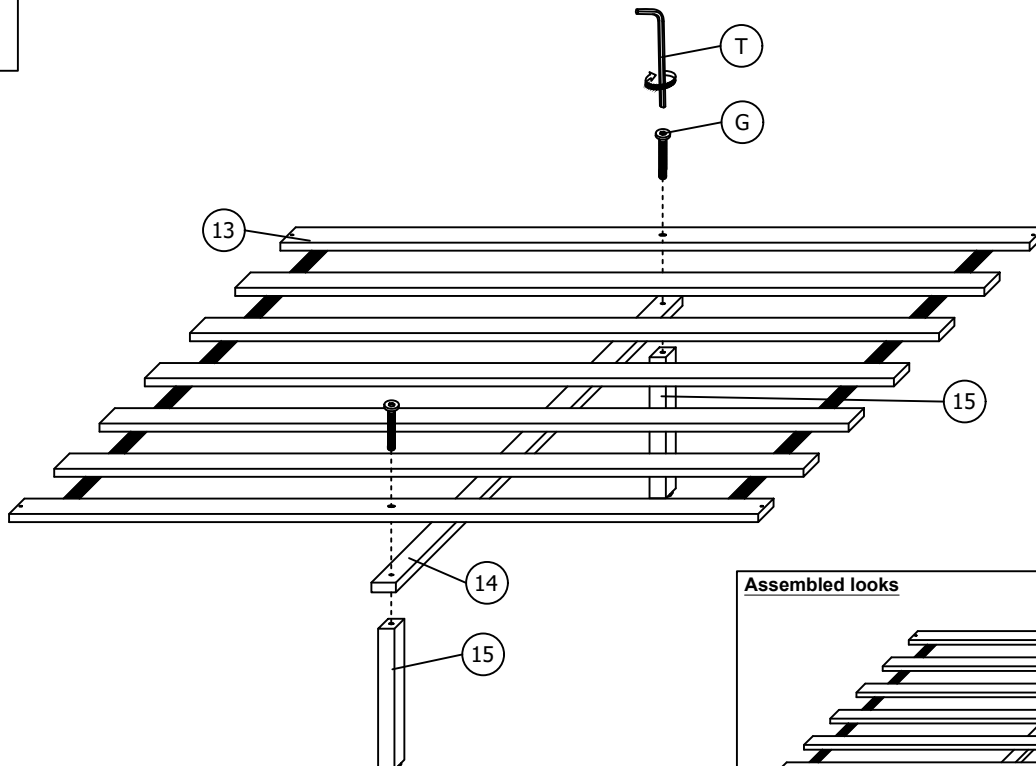

Assembled looks

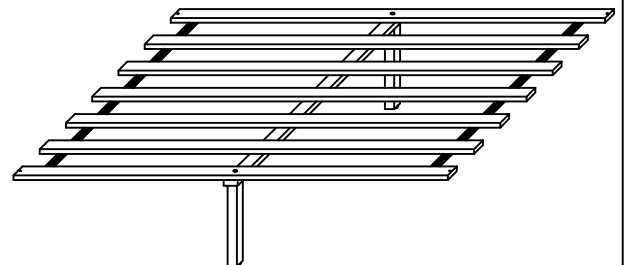

50034/50011-011/012/021/022/313/323 FB ASSEMBLY INSTRUCTION

STEP 24

Insert the 8 pieces (M) to fix the (13) on the wood of (9) and (11), then put the 2 pieces drawer inside exactly as shown.

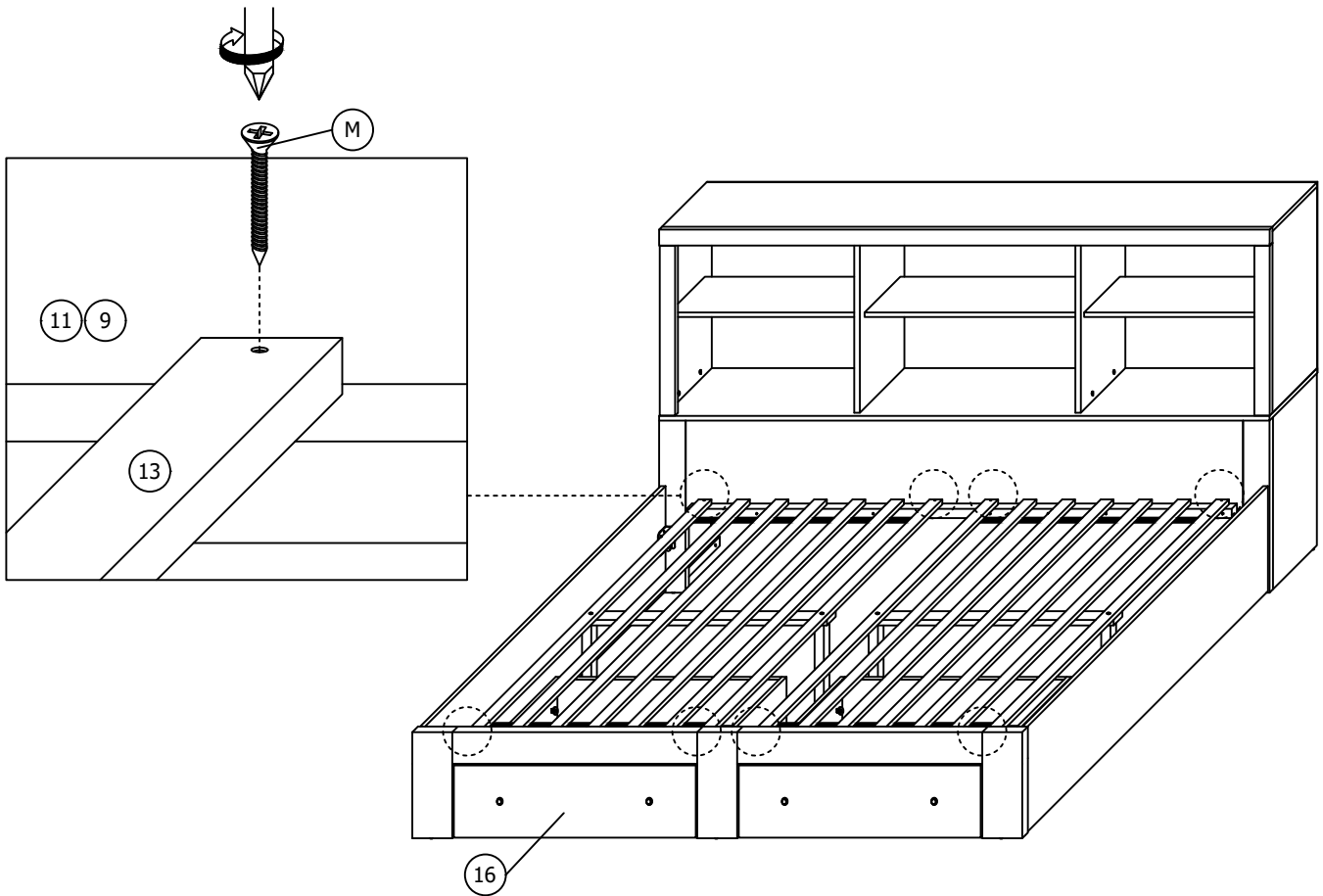

STEP 25

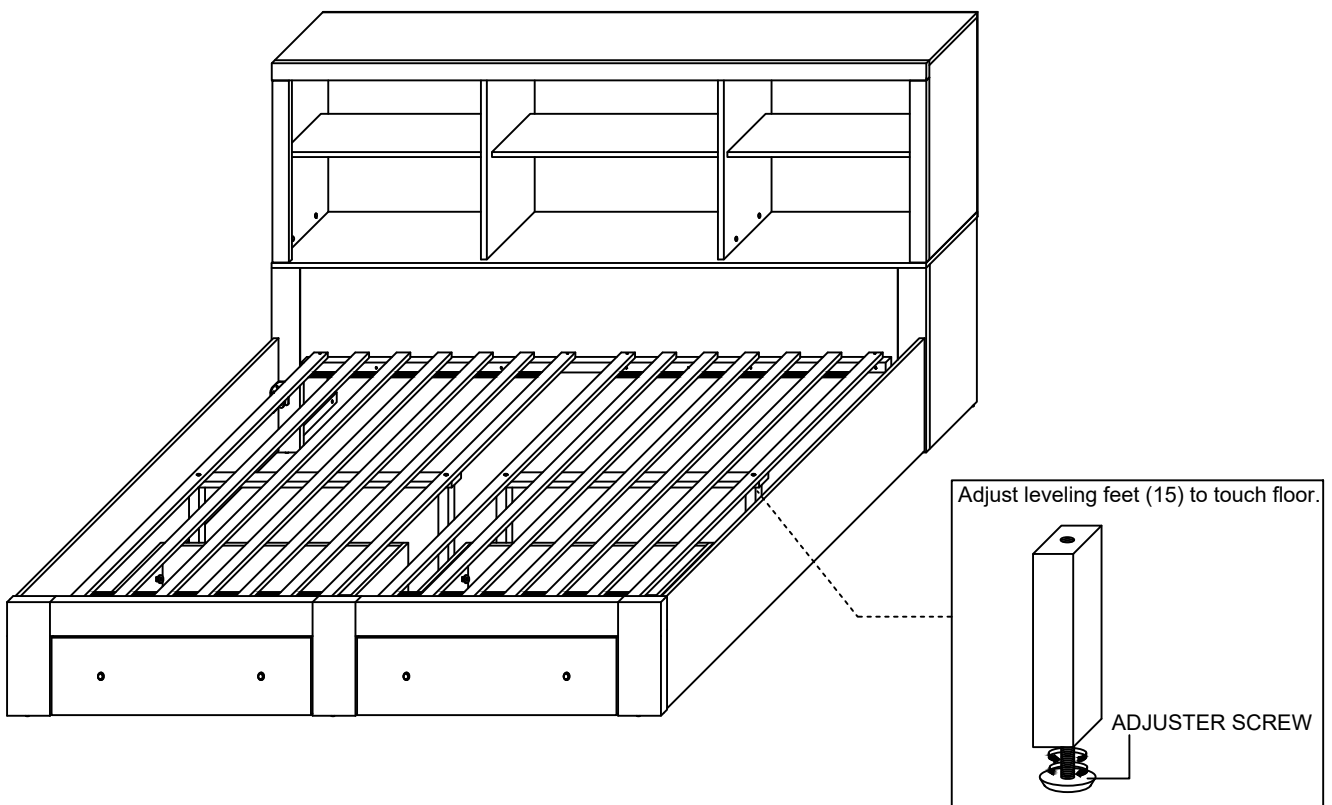

ASSEMBLY COMPLETED