

Assembly | Asambla | Assemblage

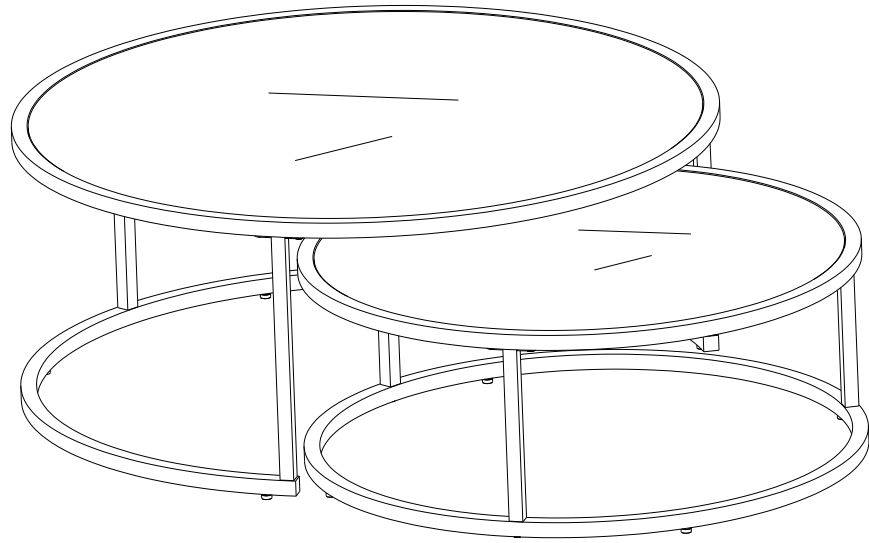

Assembly | Asambllea | Assemblage

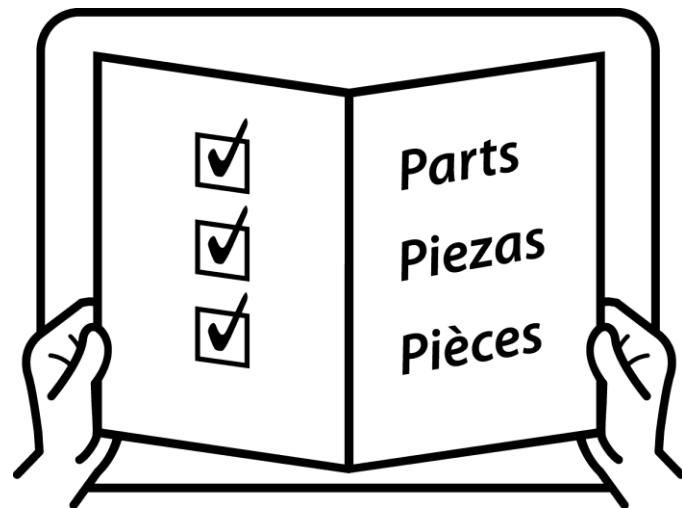
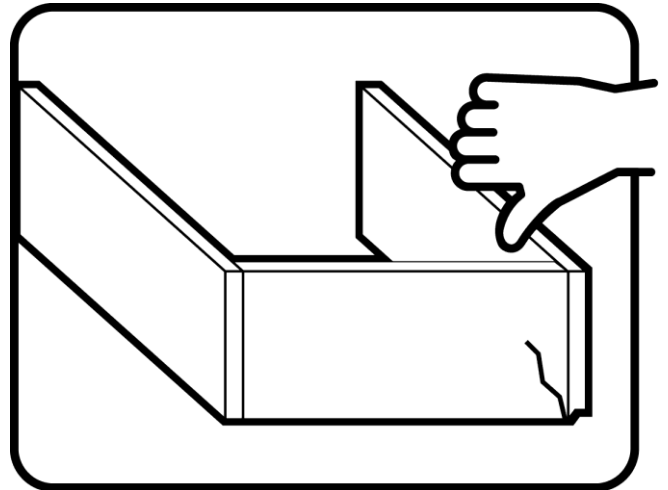
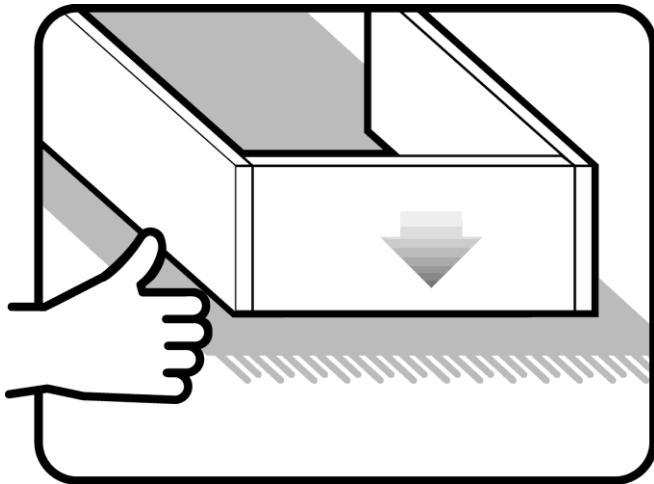
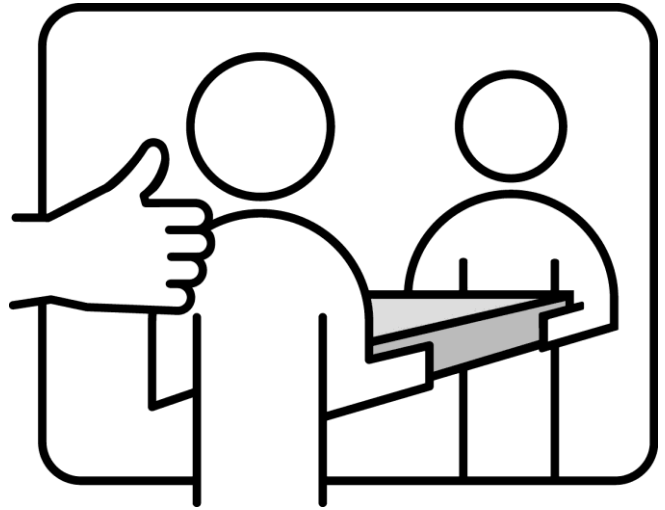
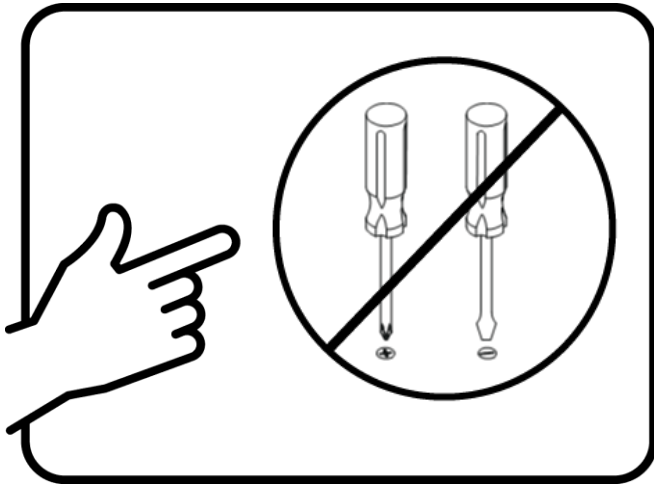

Assembly | Asamblea | Assemblage

Techniques | Técnicas | Techniques

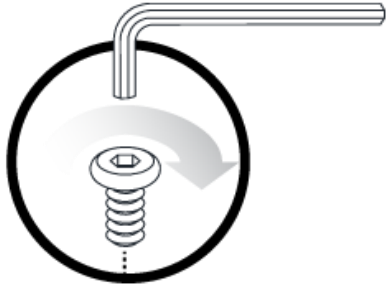

Care | Cuidado | Entretien



Safety | Seguridad | Sécurité





Note! | ¡Nota! | Remarque!

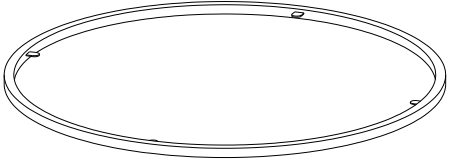
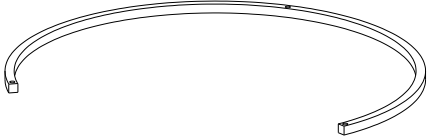
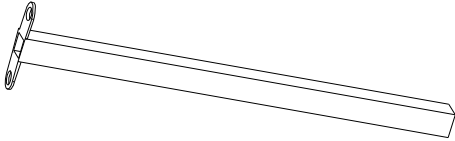
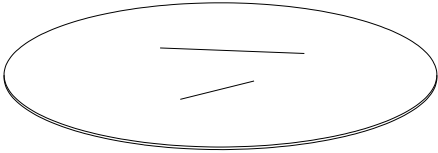
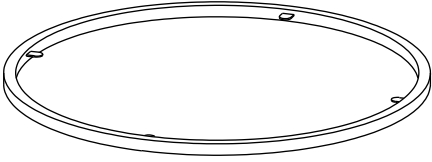
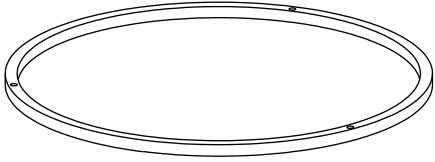
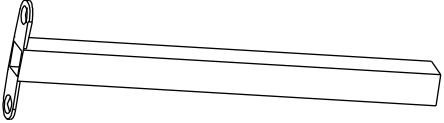
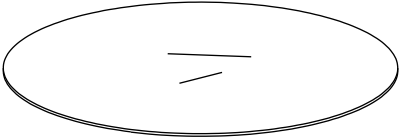

Assembly | Asambla | Assemblage

<p>1 x1</p>  <p>Top frame Marco superior Cadre supérieur</p>	<p>2 x1</p>  <p>Bottom frame Marco inferior Châssis inférieur</p>
<p>3 x3</p>  <p>Leg Pierna Jambe</p>	<p>4 x1</p>  <p>Glass top Tapa de cristal Plateau en verre</p>
<p>5 x1</p>  <p>Top frame Marco superior Cadre supérieur</p>	<p>6 x1</p>  <p>Bottom frame Marco inferior Châssis inférieur</p>
<p>7 x3</p>  <p>Leg Pierna Jambe</p>	<p>8 x1</p>  <p>Glass top Tapa de cristal Plateau en verre</p>

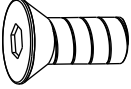
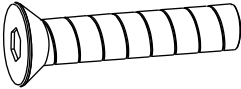
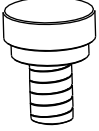
Assembly | Asamblea | Assemblage

<p>A x12</p>  <p>Bolt Tornillo Boulon 1/4"x1/2"</p>	<p>B x6</p>  <p>Bolt Tornillo Boulon 1/4"x 1-3/4"</p>	<p>C x8</p>  <p>Leveler Nivelador Niveleur</p>
<p>D x8</p>  <p>Pad for glass Almohadilla para vidrio Tampon pour verre</p>	<p>E x1</p>  <p>Allen wrench Llave Allen Clé Allen</p>	

Note: Do not fully tighten screws until all screws are in position.

Nota: No apriete completamente los tornillos hasta que todos los tornillos estén en posición.

Remarque: Ne serrez pas complètement les vis tant que toutes les vis ne sont pas en position.

Assembly | Asambla | Assemblage

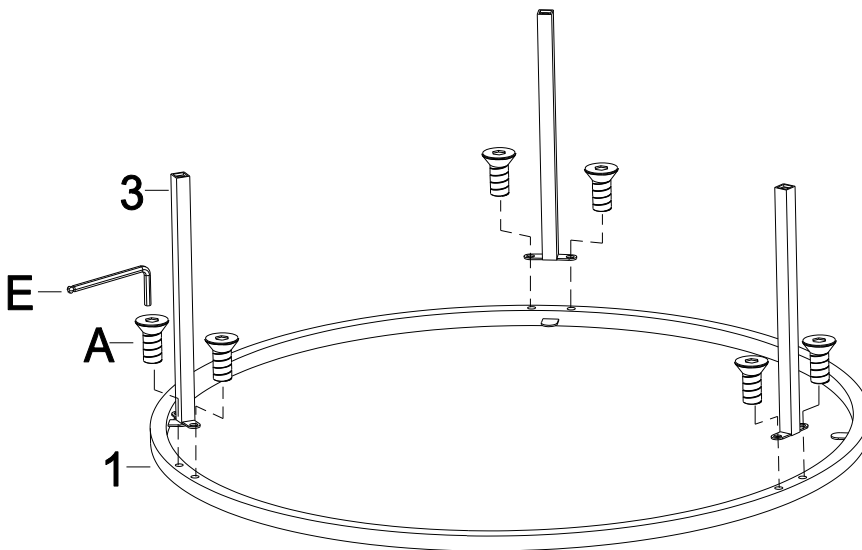

1

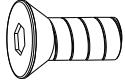
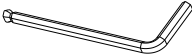

A		X6
E		X1

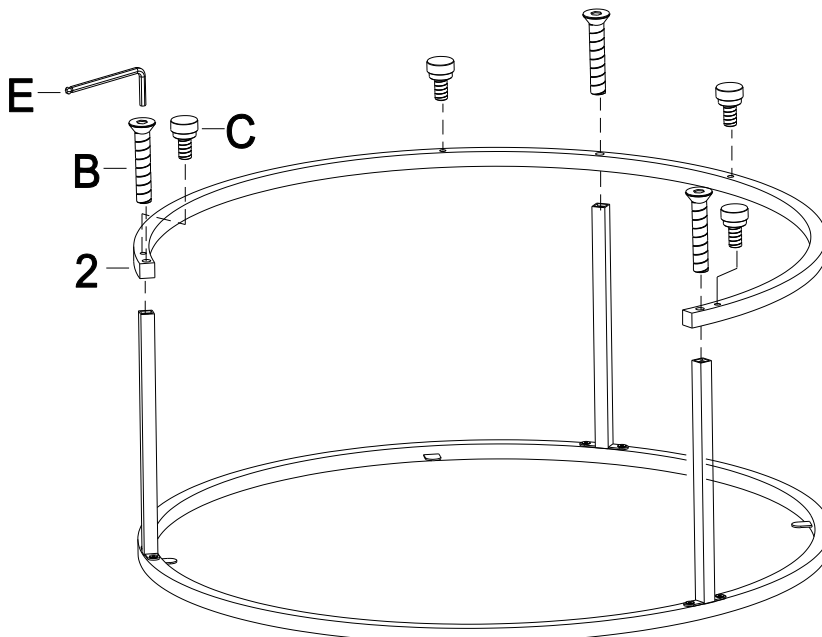
2

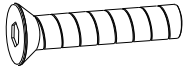

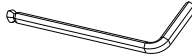
B		X3
C		X4
E		X1

Tighten all screws.

Apriete todos los tornillos.

Serrer toutes les vis.

Assembly | Asambla | Assemblage

3

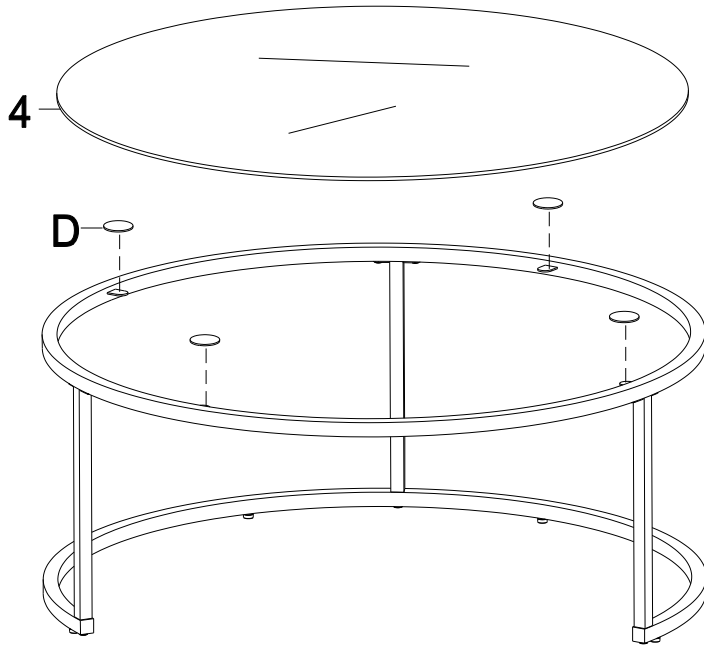

D		X4
---	---	----

4

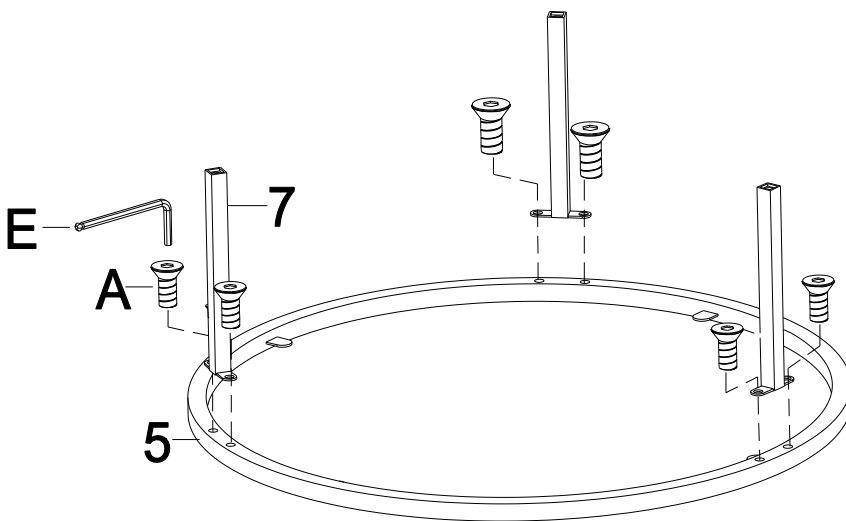

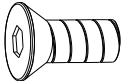
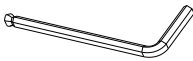

A		X6
E		X1

Assembly | Asamblea | Assemblage

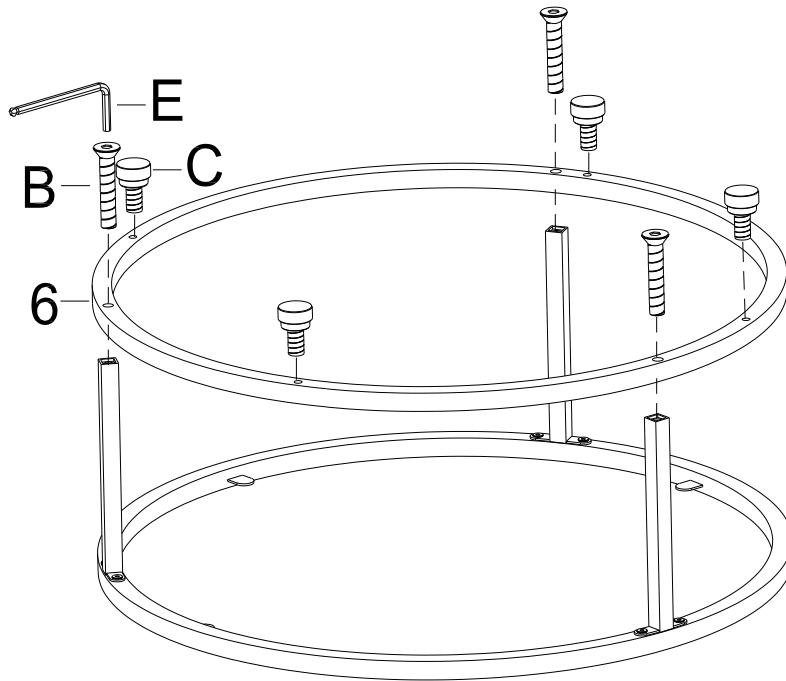
5

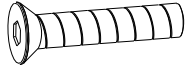

B		X3
C		X4
E		X1

Tighten all screws.

Apriete todos los tornillos.

Serrer toutes les vis.

6

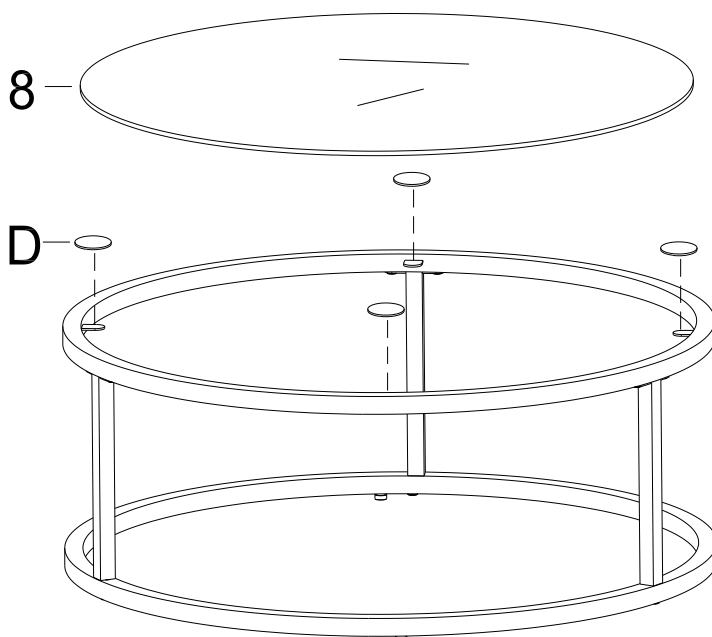

D		X4
---	---	----

Assembly | Asamblea | Assemblage

Please have this information ready when you call:

Item Number
PO #
Purchaser Name
Place of Purchase
Purchase Date
Date Product Arrived
Please immediately examine this

product carefully. Any request for missing or damaged parts replacement must be received 90 days following the date you received the product. Requests for replacement parts, if available, will be honored within this time frame. Parts will not be available for items that were received fully assembled. We do not recommend modifying products and we are not responsible for any damages due to product modifications. If damages or missing parts are not reported within 90 days of the date you received the product, we are under no obligation to provide parts or replacement merchandise. For assembly issues, please contact customer service and ask for technical assistance. Regarding product returns, please contact the retailer from whom you purchased the product.

Please note, for items purchased in a retail store, you will need to contact the retailer for all part needs.

Product purchased at garage sales or discount stores is sold as-is and is not covered by the above policy.

Tenga a mano esta información cuando llame:

Articulated knob
PO
Nombre del comprador
Lugar de compra
Fecha de compra
Fecha en que llegó el producto

Por favor, examine ester producto detenidamente. Cualquier solicitud de reemplazo de piezas faltantes o dañadas debe recibirse 90 días después de la fecha en que recibió el producto. Las solicitudes de piezas de repuesto, si están disponibles, se cumplirán dentro de este marco de tiempo. Las piezas no estarán disponibles para los artículos que se recibieron completamente ensamblados. No recomendamos modificar los productos y no nos hacemos responsables de los daños debidos a modificaciones del producto. Si los daños on las piezas faltantes no se informan dentro de los 90 días a partir de la fecha en que recibió el producto, no estamos obligados a proporcionar piezas on mercancía de reemplazo. Para problemas de montaje, comuníquese con el servicio al cliente y solicite asistencia técnica. En cuanto a devoluciones de productos, póngase en contacto el distribuidor al que le compró el producto.

Tenga en cuenta que para los artículos comprados en una tienda minorista, deberá ponerse en contacto con el minorista para todas las necesidades de la pieza.

El producto comprado en las ventas de garageje o tiendas de descuento se vende tal cual y no está cubierto por la política anterior.

Veillez avoir cette information à portée de main lorsque vous appelez:

Article Number
PO#
Nom de l'acheteur
Lieu d'achat
Date d'achat
Date of arrival of the product

S'il vous plaît examiner immédiatement ce produit avec soin. Toute demande de remplacement de pièces manquantes ou endommagées doit être reçue dans les 90 jours suivant la date de réception du produit. Les demandes for pièces de change, si elles sont disponibles, seront honorées dans ce délai. Les pièces ne seront pas disponibles pour les articles reçus entièrement assemblés. Nous ne recommandons pas de modifier les produits et nous ne sommes pas responsables des dommages causés par les modifications du produit. Si les dommages ou les pièces manquantes ne sont pas signalés dans les 90 jours suivant la date à laquelle vous avez reçu le produit, nous ne sommes pas tenus de fournir des pièces ou des marchandises de remplacement. Pour les problèmes d'assemblage, veuillez contacter le service clientèle et demander une assistance technique. En ce qui concerne les retours de produits, veuillez contacter le revendeur auprès duquel vous avez acheté le produit.

S'il vous plaît noter, pour les articles achetés dans un magasin de détail, vous devrez contacter le détaillant pour tous les besoins en pièces.

Les produits achetés dans les ventes de garage ou dans les magasins discount sont vendus tels quels et ne sont pas couverts par la politique cidessus.