

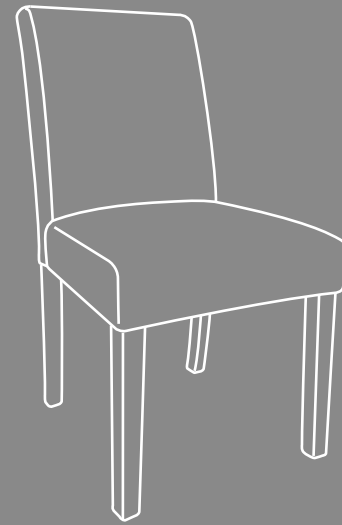





Dining Chair

Instruction Manual



SUMMARY

-  1 - ITEMS DELIVERED-TECHNICAL DATA 1
-  2 - ASSEMBLY 2
-  3 - CLEANING AND MAINTENANCE 4
-  4 - DISPOSAL 5
-  5 - GUARANTEE 5

1- ITEMS DELIVERED - TECHNICAL DATA

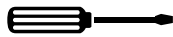
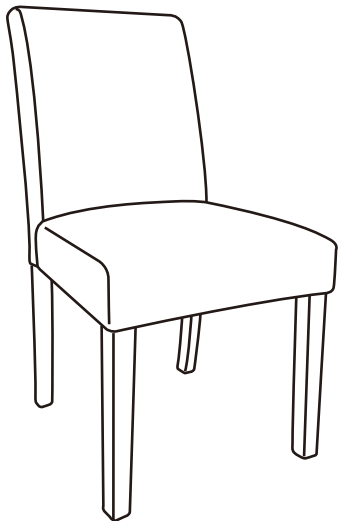







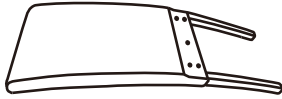
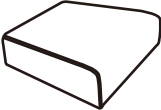

Require Assembly



ASSEMBLY
EASY

2 - ASSEMBLY

 (1)X1	 (2)X1
 (3)X2	 M8*75mm (A)X4
 M8*55mm (B)X5	 M8 (C)X9
 M8 (D)X9	 M8 (E)X1
 (F)X1	



(2)X1

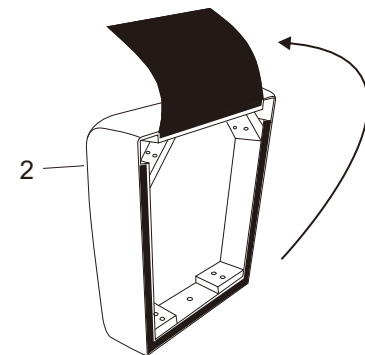

2



(1)X1



(2)X1



M8*75mm

(A)X4



M8*55mm

(B)X1



M8

(D)X5



M8

(C)X5



M8

(E)X1

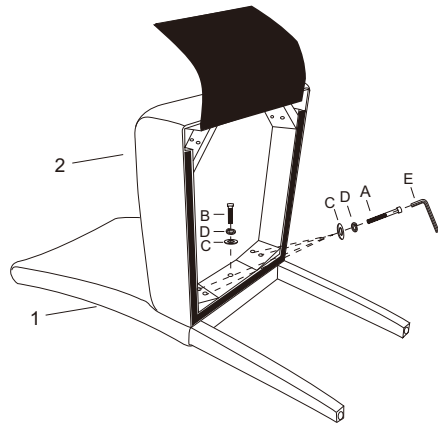

3



(3)X2



M8*55mm

(B)X4



M8

(D)X4



M8

(C)X4

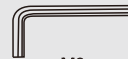
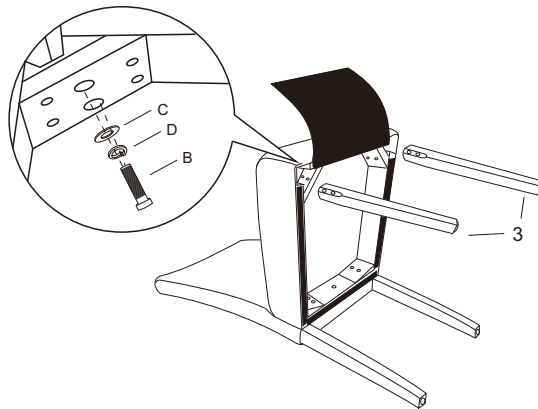

M8

(E)X1

4

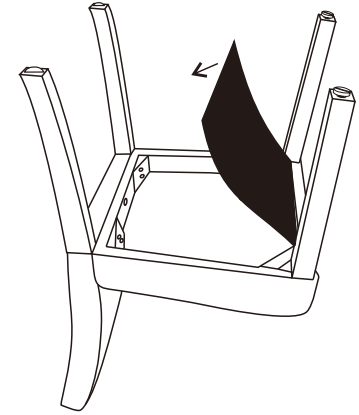

5



Place the chair on a level surface and keep 4 legs straight down on the floor, then tighten up all screws to 100%. Turn the pin at the bottom of the front legs to make chair level.

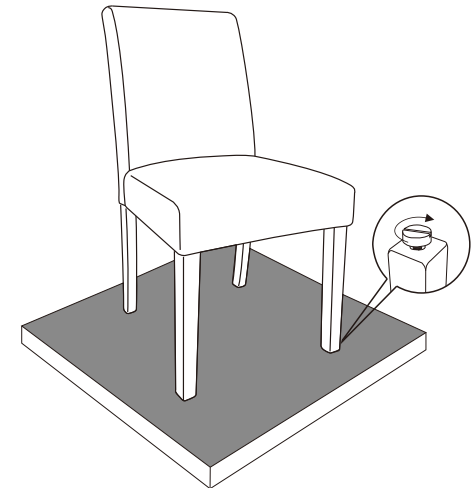



3 - CLEANING AND MAINTENANCE

- Do not use corrosive or abrasive for cleaning products.
- Clean with a soft cloth.
- Don't interfere with metal objects in a mechanism, so that they are threatened with serious deterioration.



4 - DISPOSAL

The product is recyclable, subject to the manufacturer's extended responsibility, and must be selectively classified.



Packaging

If you want to dispose of the packaging, Please comply with the corresponding environmental regulations in your country.



5 - GUARANTEE

Dear Buyer,

Our products are always on strict quality control. When you find the items you received can not work normally, please contact our customer service at once.

Best Method: Contact Us Directly on the Platform You Purchasing this Item

This warranty applies to defects of material and manufacturing. Vulnerable parts and fragile parts damaged by normal wear and tear are not covered by this warranty.

Lieber Käufer,

unsere Produkte unterliegen immer einer strengen Qualitätskontrolle. Wenn Sie feststellen, dass die von Ihnen erhaltenen Artikel nicht normal funktionieren, wenden Sie sich bitte sofort an unseren Kundenservice.

Best Method: Kontaktieren Sie uns direkt auf der Plattform, auf der Sie diesen Artikel kaufen

Diese Garantie gilt für Material- und Herstellungsfehler. Anfällige Teile und zerbrechliche Teile, die durch normalen Verschleiß beschädigt wurden, sind von dieser Garantie nicht abgedeckt.

Gentile acquirente,

I nostri prodotti sono sempre sotto stretto controllo di qualità. Quando trovi che gli articoli che hai ricevuto non possono funzionare normalmente, contatta subito il nostro servizio clienti.

Metodo migliore: contattaci direttamente sulla piattaforma che acquisti questo articolo

Questa garanzia si applica ai difetti di materiale e fabbricazione. Le parti vulnerabili e le parti fragili danneggiate dalla normale usura non sono coperte da questa garanzia.

Cher acheteur,

Nos produits sont toujours soumis à un contrôle qualité strict. Lorsque vous constatez que les articles que vous avez reçus ne peuvent pas fonctionner normalement, veuillez contacter notre service client immédiatement.

Meilleure méthode : contactez-nous directement sur la plate-forme sur laquelle vous achetez cet article

Cette garantie s'applique aux défauts de matériaux et de fabrication. Les pièces vulnérables et les pièces fragiles endommagées par l'usure normale ne sont pas couvertes par cette garantie.

Estimados,

Estimado comprador,

Nuestros productos están siempre bajo estrictos controles de calidad. Si el taburete no funciona bien por defectos de fabricación o mal material, por fa comuníquese con nosotros para ofrecerle mejor servicio!

Mejor método: contáctenos directamente en la plataforma en la que compra este artículo

Esta garantía se aplica a defectos de material y fabricación. Las piezas vulnerables y frágiles dañadas por el desgaste normal no están cubiertas por esta garantía.

親愛なるバイヤー、

当社の製品は常に厳格な品質管理下にあります。受け取った商品が正常に使用できない場合は、お早めにカスタマーサービスまでご連絡ください。

最善の方法: この製品を購入したプラットフォームで直接お問い合わせください

この保証は、材料および製造上の欠陥に適用されます。通常の摩耗によって損傷した脆弱な部品や壊れやすい部品は、この保証の対象外です。