

# Assembly Instructions PASCAL Office Chair

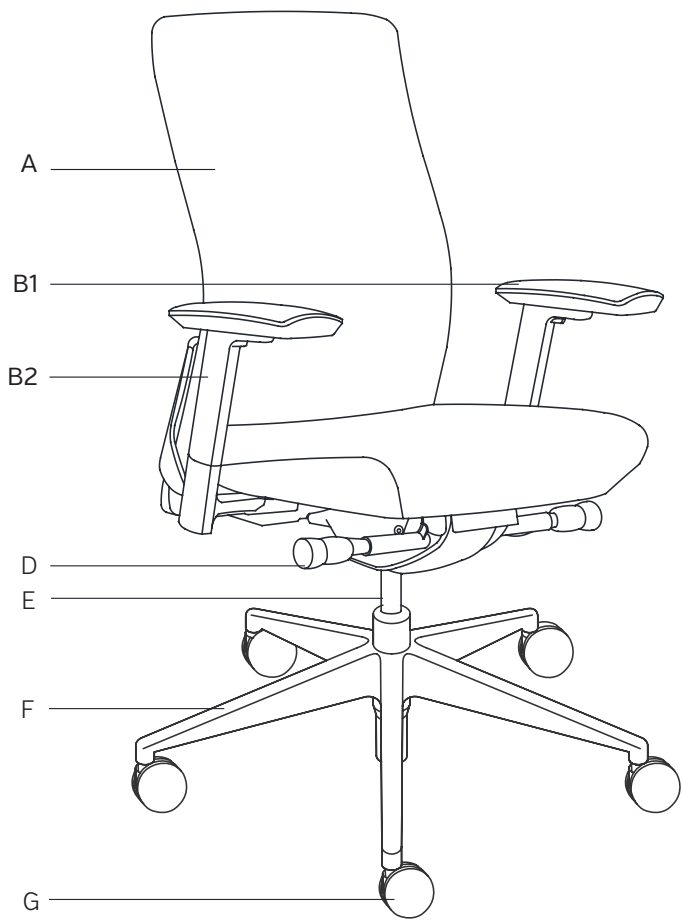

Item	Image	Part Name	Part #	Qty
A		Back Frame Black/White	G00300/G00311	1
B1		Left Arm Black/White	G00301/ G00312	1
B2		Right Arm Black/White	G00302/G00313	1
C1		Left Arm Black/White	G00303/G00314	1
C2		Right Arm Black/White	G00304/G00315	1
D		Seat Pan Black/White	G00305/G00316	1
E		Gas Cylinder	G00306	1
F		Base	G00026	1
G		Caster	G00008	5
H		Short Bolt M8x20	G00307	3
I		Long Bolt M6x35	G00308	6
J		Hex Wrench	G00137	1
K		Lock Washer M8	G00309	3
L		Flat Washer M8	G00310	3
M		Pivot Lock Bracket	G00067	2
N		Slide Lock Bracket	G00068	2

\* Arms are packed in a separate box  
 \*\* Optional arm pad pivot and slide locks for task chair; see instructions on page 2.

### Warning

1. Product is for single person use only.
2. Do not use this chair unless all screws are securely tightened.
3. Check all screws are tightened every six months or as needed.
4. Dispose of packing material properly. Do not use plastic cover as a head covering. Suffocation may result.
5. Do not use this chair as a stepladder.

**1 Base Assembly**  
 Firmly snap Casters [G] into Base [F]. Place base on ground with casters attached. Drop Gas Cylinder [E] into base with skinny end pointing up.

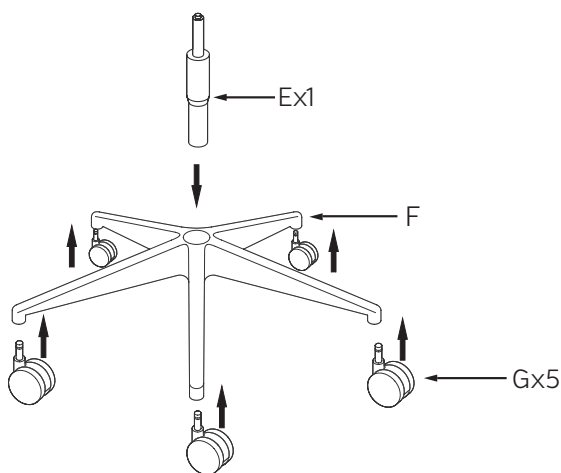

**2A 415 Task Chair Arm Assembly**  
 Using the Long Bolts [I] screw in the arms to the underside of the Seat Pan.

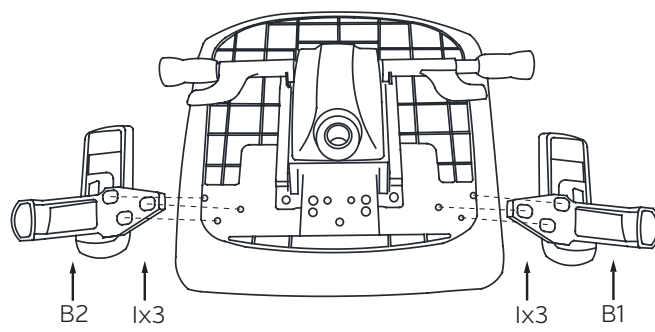

**2B 416 Conference Chair Arm Assembly**  
 Using the Long Bolts [I] screw in the arms to the underside of the Seat Pan.

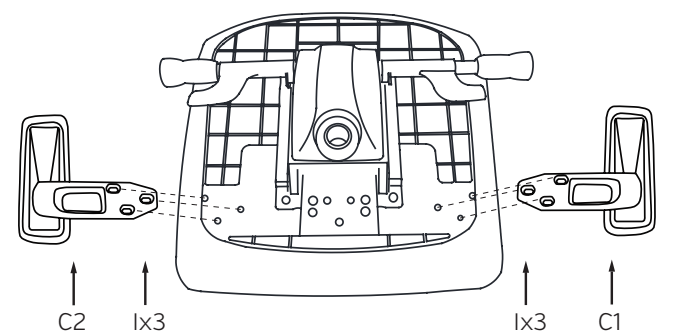

**3 Seat /Back Assembly**  
 Carefully align the Back Frame [A] to Seat Pan [D]. Tighten Back Frame to the Seat Pan using Short Bolt [H], Lock Washer [K] and Flat Washer [L].

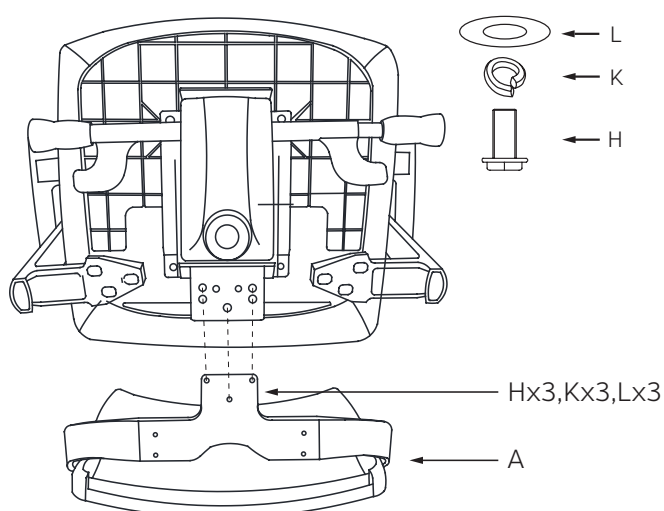

**4A Task Chair Final Assembly**  
 With the Base on the ground, carefully align the Gas Cylinder with the hole in the center of the underside of the Seat Pan, applying pressure.

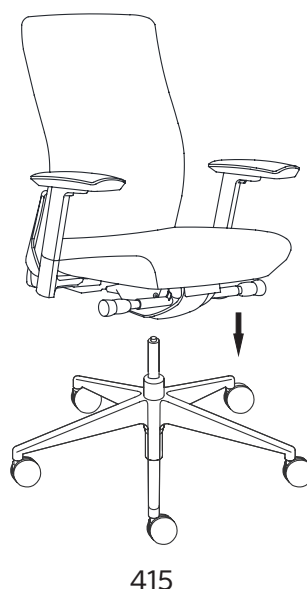

**4B Conference Chair Final Assembly**  
 With the Base on the ground, carefully align the Gas Cylinder with the hole in the center of the underside of the Seat Pan, applying pressure.

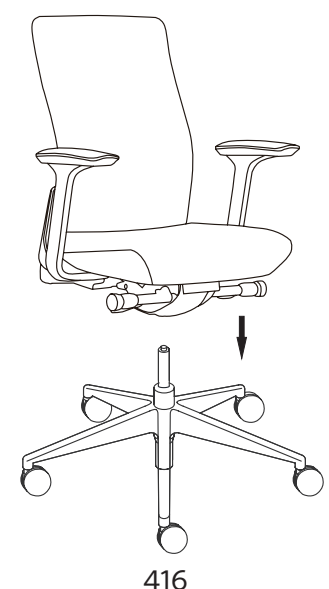

**Instructions for Arm Pad Pivot & Slide Locks for Task Chair [Optional]**

1

M  x2

N  x2

Item M & Item N

2

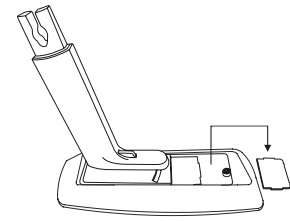

Slide the arm pad back and take a flat screwdriver and pop off the cover

3

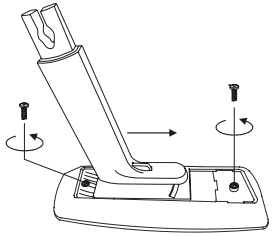

Slide the arm pad forward and remove screws

4

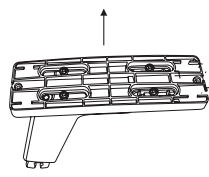

Remove the arm pad

5

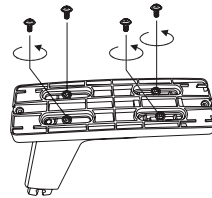

Remove four screws that secure the part for sliding

6

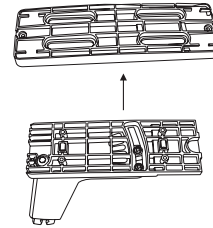

Remove part

7

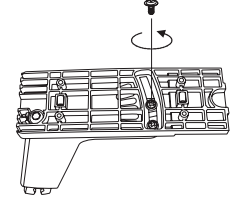

Make sure the angle adjustment is straight, then remove center screw

8

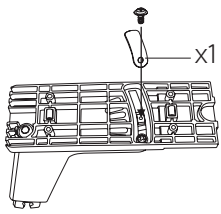

Place Item M and use the same screw to secure it

9

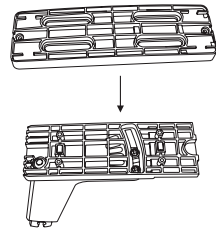

Place sliding part back on

10

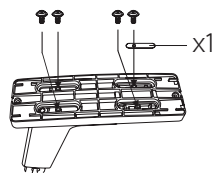

Pick any of the screw holes to install item N and use the same screw to secure it

11

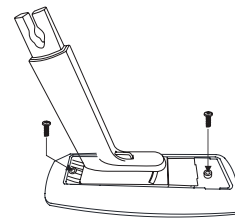

Reinstall the arm pad using the same two screws and secure the pad.

12

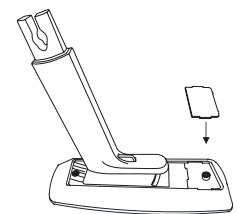

Reinstall cover

**Assembly Instructions Slip Cover [Optional]**

1

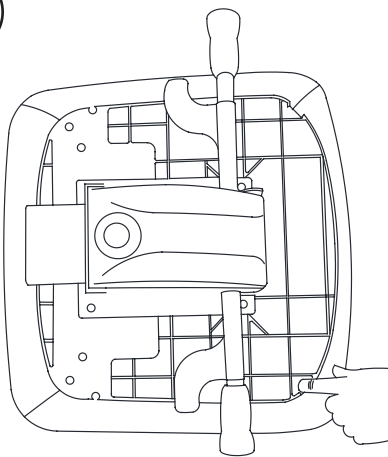

Use finger to pull & remove the seat cover stiffener

2

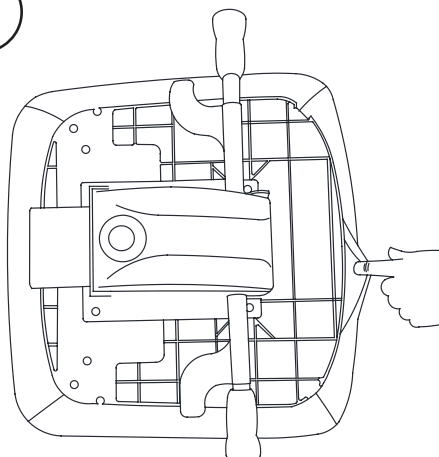

Pull along edge to remove seat cover

3

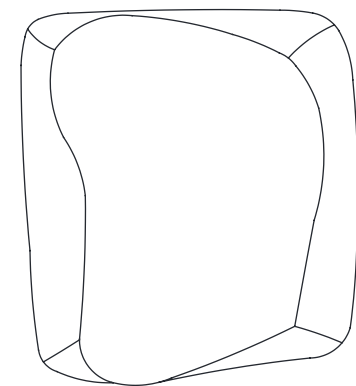

New seat cover

4

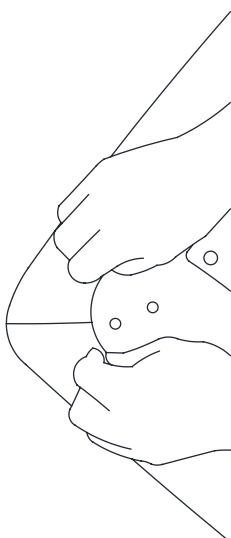

Re-insert the seat cover stiffener

5

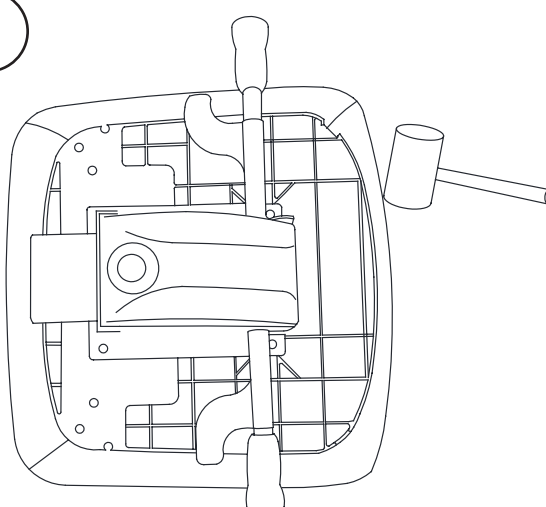

Use rubber hammer to tap fit the seat cover with the seat base