

INSTRUCTION MANUAL

70" TV Stand with Fireplace

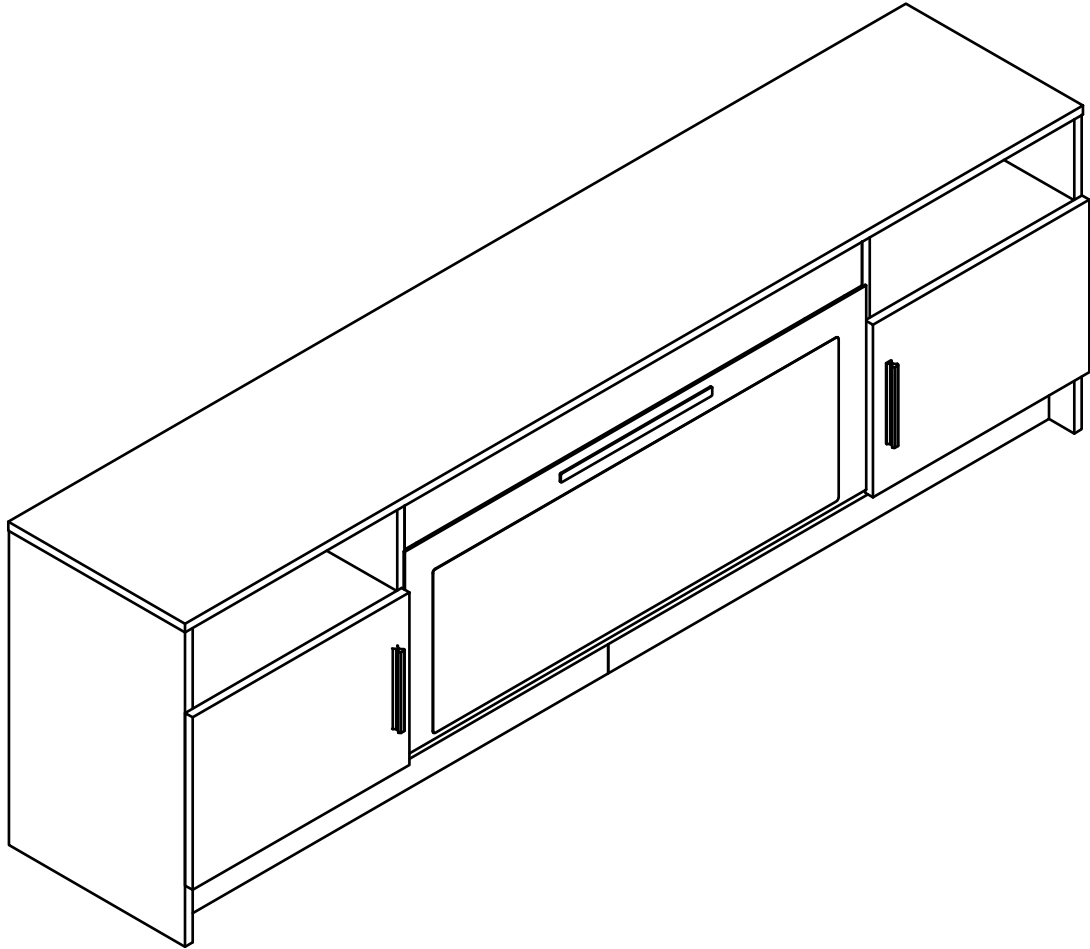

NOTE: This product is divided into 2 packages and may arrived on different days. Please make sure that all packages are delivered before unpacking and assembling the product, if you have any questions, contact us ASAP.

WELCOME TO THE FUTURE !

Thank you for choosing our new electric fireplace and TV stands! Our products are designed to be both stylish and functional, with a focus on energy efficiency and sustainability.

We use high-quality materials to ensure that our pieces are built last, so you can enjoy them for years. Whether you're looking for a cozy electric fireplace or a stylish TV stand, we have something for everyone.

Our products are perfect for any home or office, and we're confident that you'll love them as much as we do!

NOTICE

- 1.Children are not allowed to operate
2. Faster installation is possible with power tools.
3. Do not pull the door vigorously to prevent the storage cabinet from tipping over.
- 4.Please attach the storage cabinet to the wall with an anti-tip device after installation is complete.
5. When using the storage cabinet for the first time,please keep it in a ventilated environment to allow the smell to fully evaporate.
- 6.When placing the partitions,please make sure the nails are firmly installed to prevent the partitions from falling off.
7. If any parts are missing,broken,damaged or worn,discontinue use of the product until repairs are made and/or factory replacement parts are installed
8. Do not use this product in a manner inconsistent with the manufacturer's instructions as this may void the product warranty
- 9.If accessories are missing, please contact customer service for communication in time, we provide 7x24 hours after-sales service
- 10.Do not use any attachments or accessories other than the original factory attachments and accessories
- 11.Do not alter this equipment. Any alteration will create a safety hazard.

BEFORE YOU START

- ⚠ Please read all instructions carefully.
- ⚠ Retain instructions for future reference.
- ⚠ Separate and count all parts and hardware.
- ⚠ Read through each step carefully and follow the proper order.
- ⚠ We recommend that, where possible, all items are assembled near to the area in which they will be placed in use, to avoid moving the product unnecessarily once assembled.
- ⚠ Always place the product on a flat, steady and stable surface.
- ⚠ Keep all small parts and packaging materials for this product away from babies and children as they potentially pose a serious choking hazard.

PRE-INSTALLATION

GRAB YOUR TOOLS



Phillips Screwdriver



2 Persons Assembly



Up to 60 Minutes For Assembly

WHAT'S IN THE BOX

1

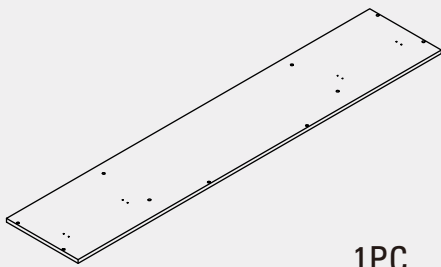

1PC

2

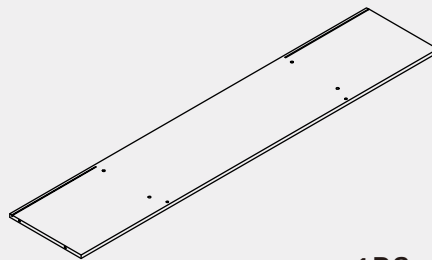

1PC

3

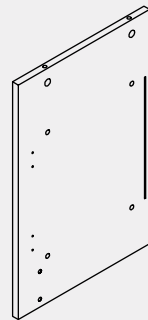

1PC

4

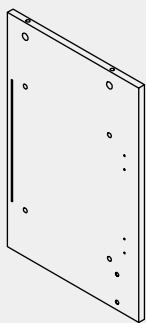

1PC

5

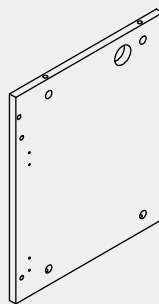

1PC

6

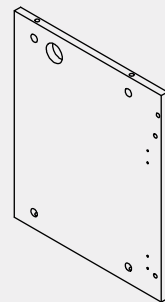

1PC

7

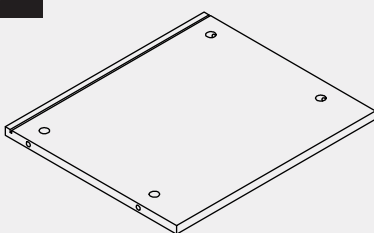

2PCS

8

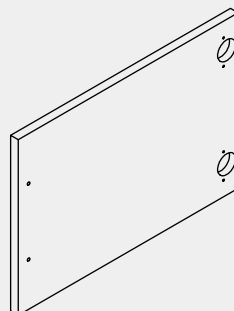

2PCS

9

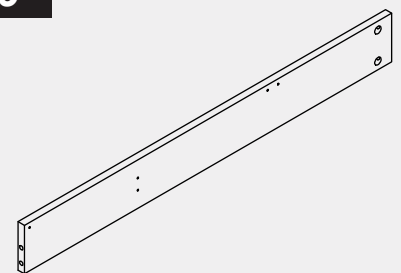

1PC

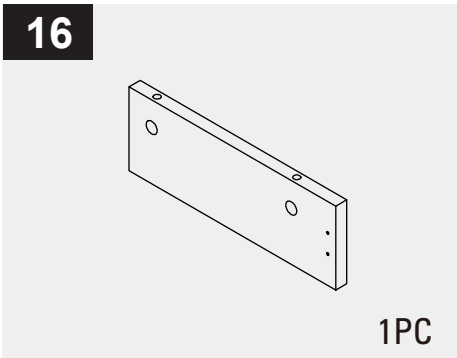
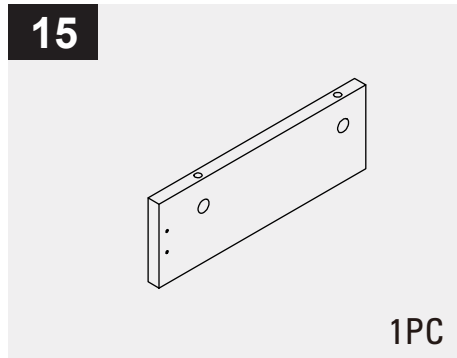
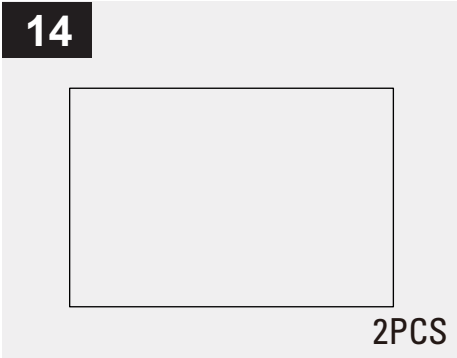
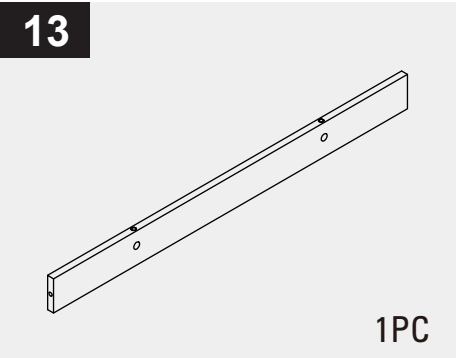
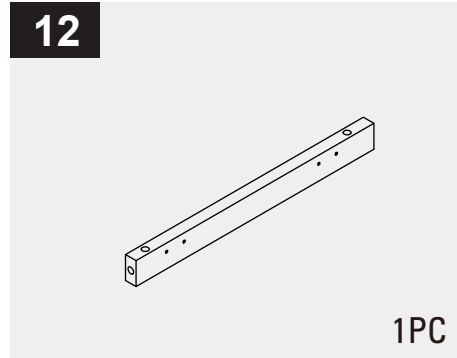
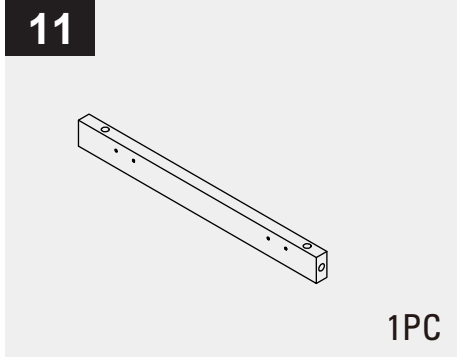
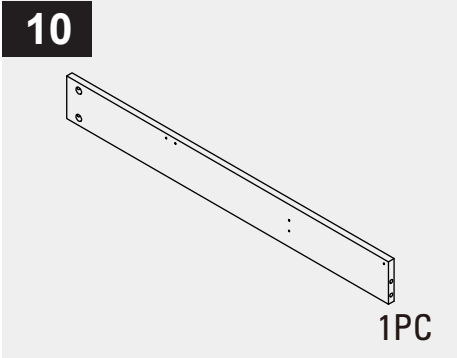

HARDWARE

A

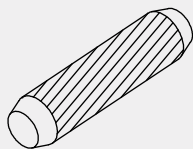

Φ 8*30mm

10PCS

B



Φ15*12mm

34+1PCS

C

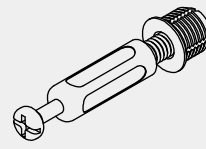

Φ6*43mm

34+1PCS

D

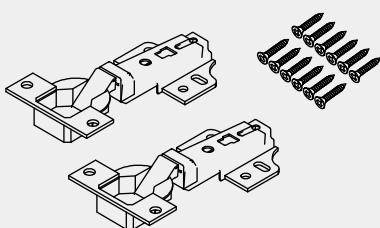

2PCS

E



K3.5*14mm

36+2PCS

F

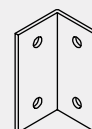

9PCS

G



M4*18mm



2PCS

PRE-ASSEMBLY PREPARATION

Ensure all parts and hardware are included in the package.
Lay out all components on a flat, soft surface to avoid scratches.

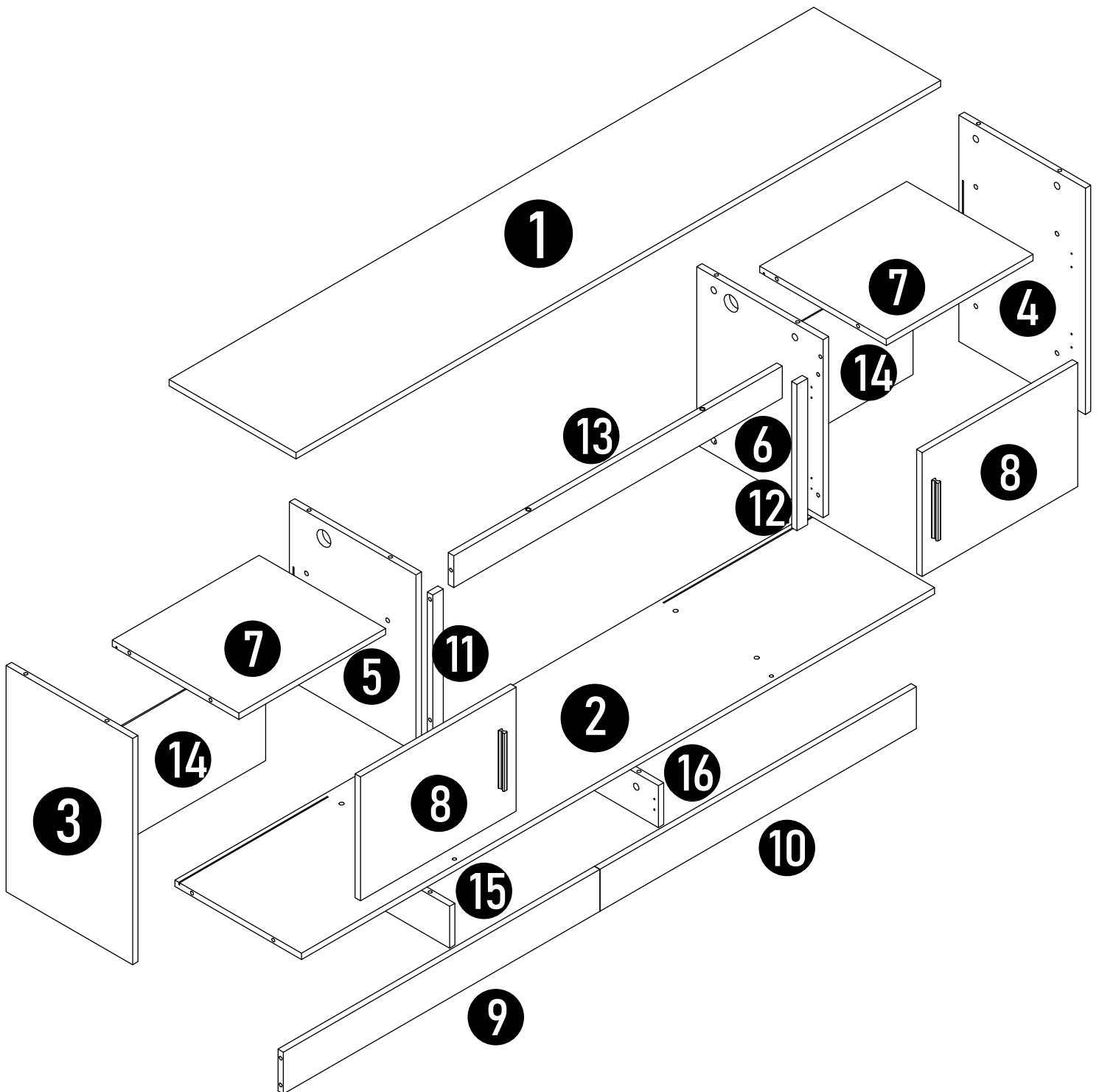

PRODUCT ASSEMBLY

STEP 1

Make sure that the small holes on part ⑮ and part ⑨ are on the same side, and the small holes on part ⑯ and part ⑩ are also on the same side. This ensures correct installation.

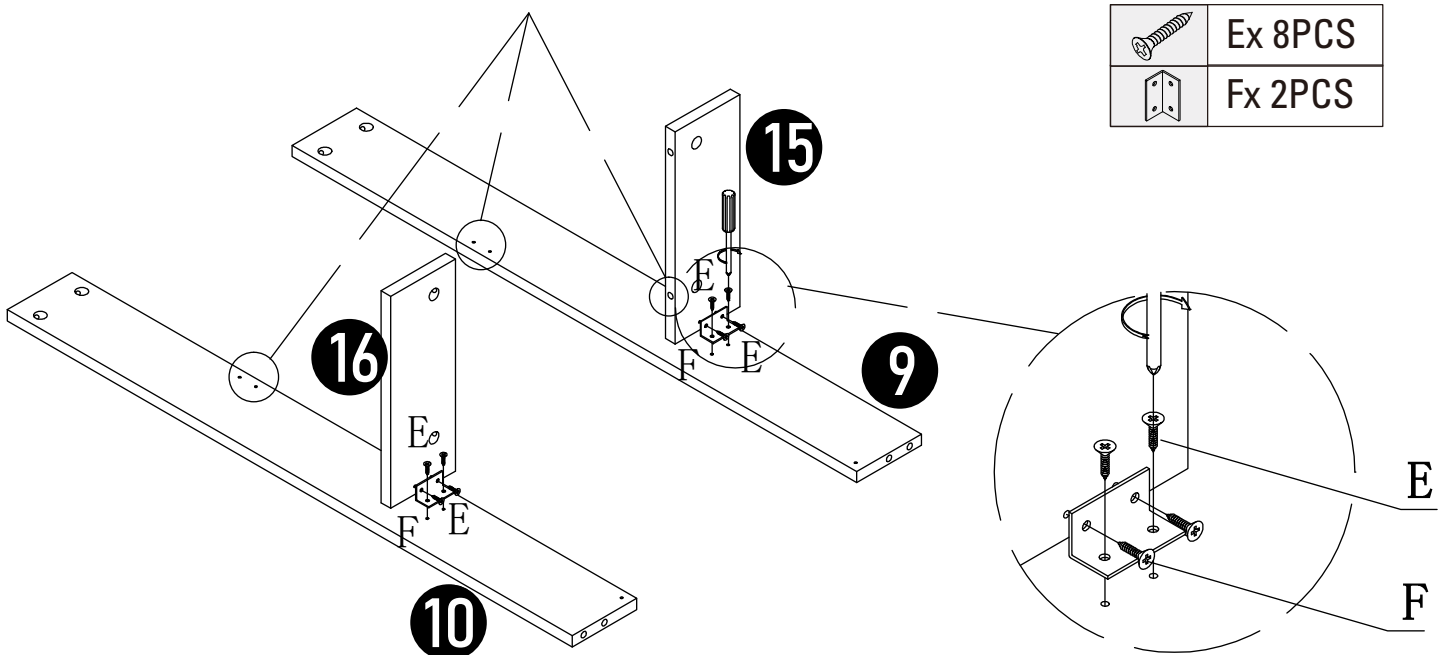

STEP 2

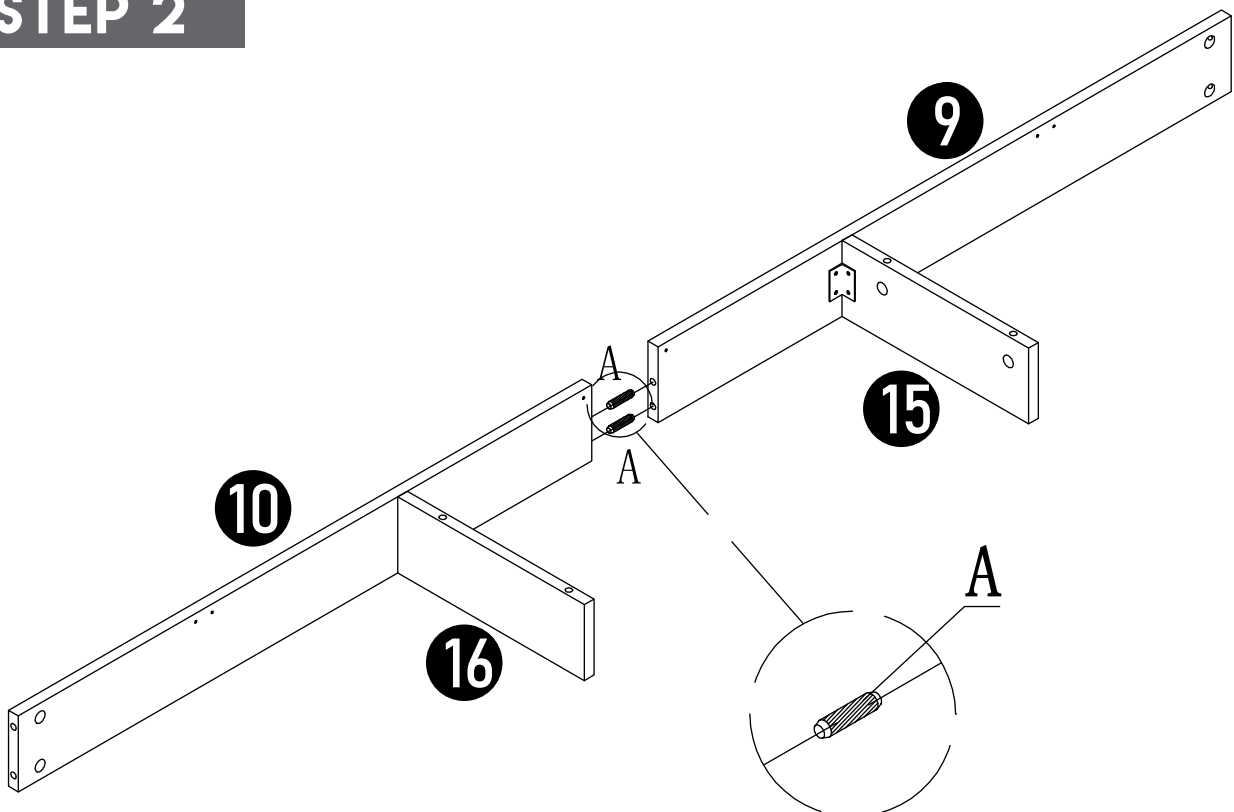

PRODUCT ASSEMBLY

STEP 3

 C x 4PCS

First, press part C down into the hole until the white plastic threads are fully inserted into the hole, then screw in the pin clockwise.

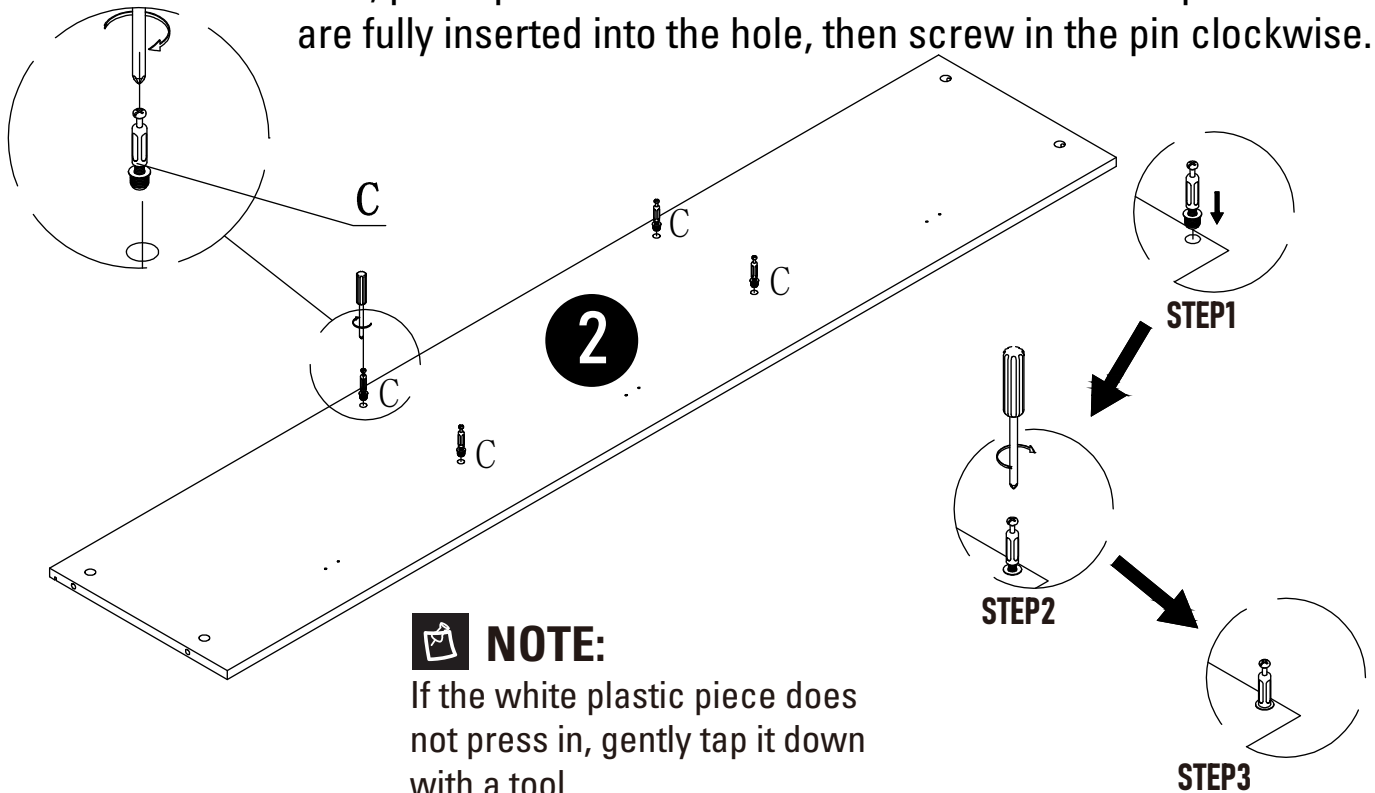

STEP 4

Flip the assembly from STEP 2 and use 4 pieces of B to connect with part ②.

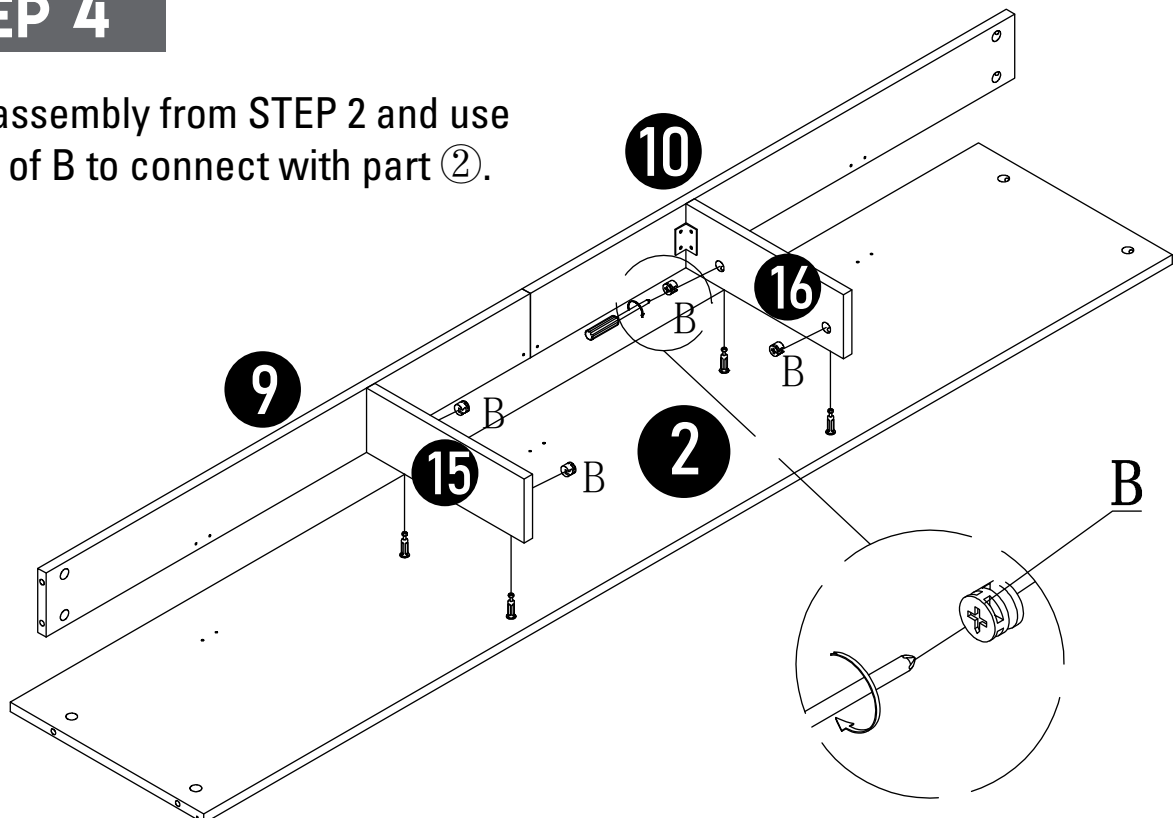

 B x 4PCS

PRODUCT ASSEMBLY

STEP 5

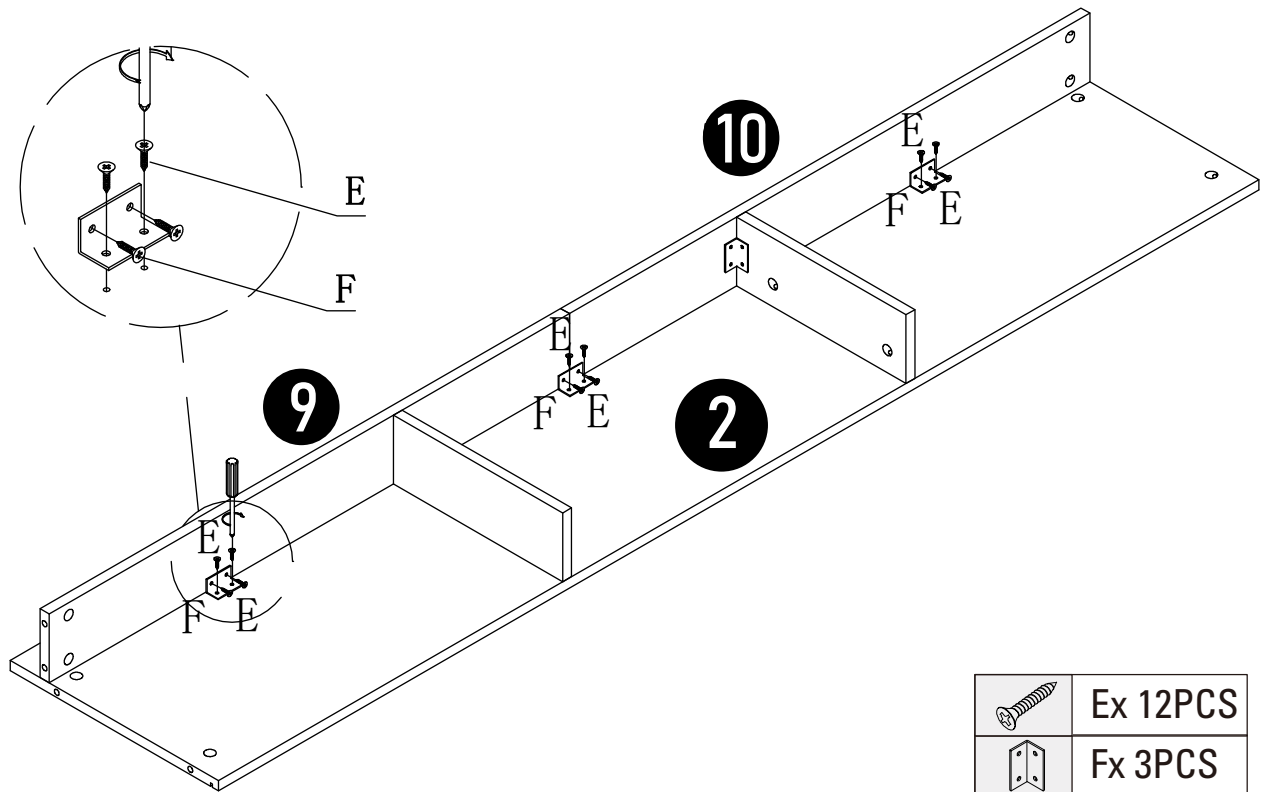

STEP 6

Flip the assembly from STEP 4 and install the 4 pieces of C into the corresponding holes.

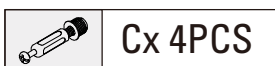
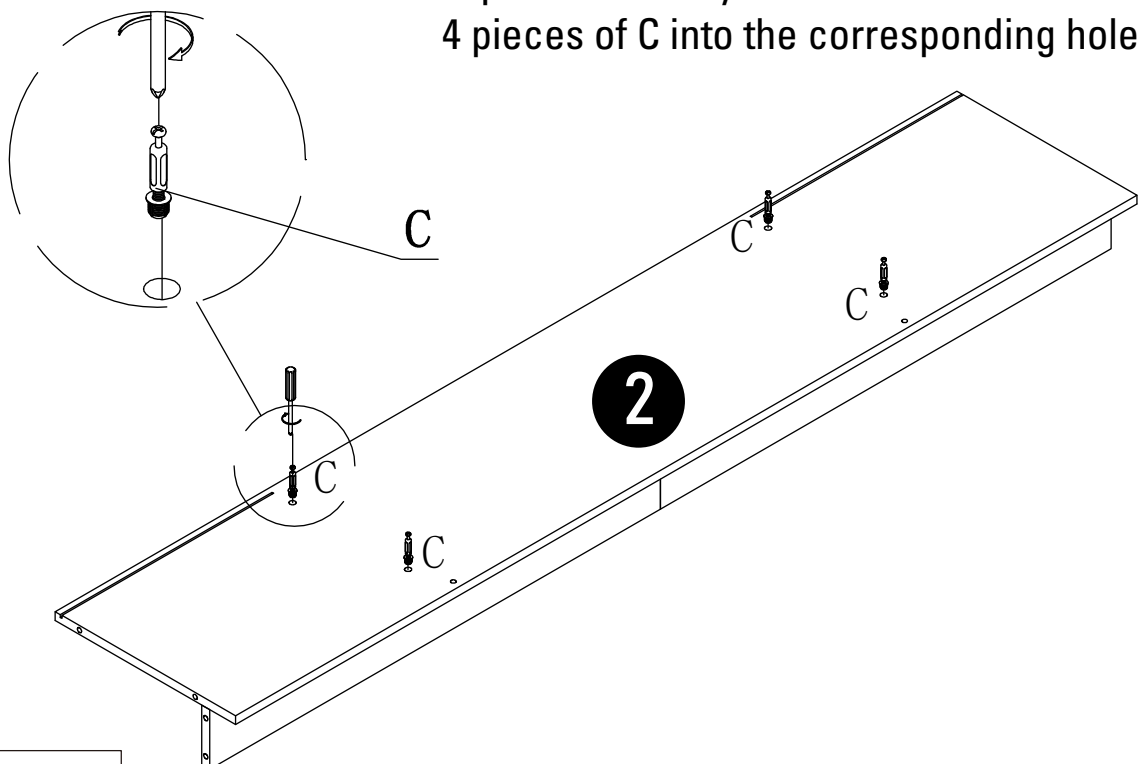

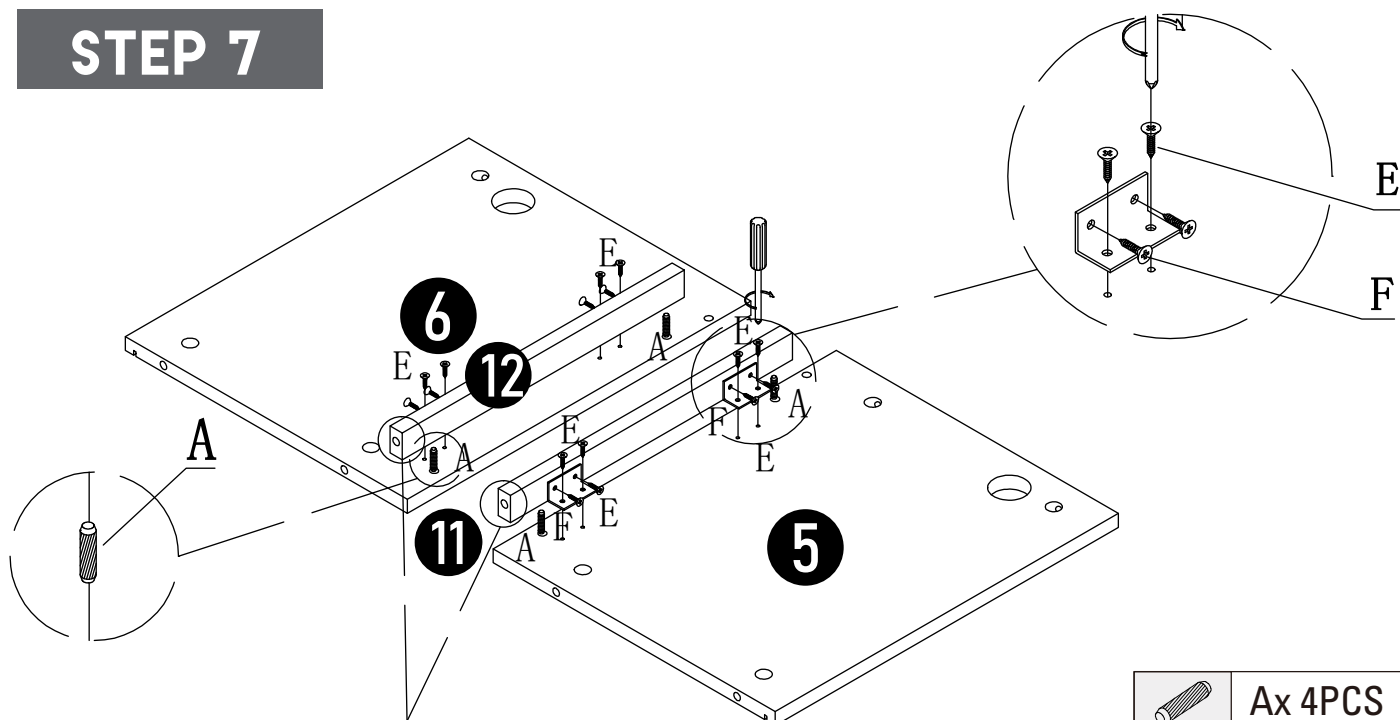

PRODUCT ASSEMBLY

STEP 7



Make sure that the sides with holes on parts ⑪ and ⑫ are aligned flush with parts ⑤ and ⑥ for correct installation.

	Ax 4PCS
	Ex 16PCS
	Fx 4PCS

STEP 8

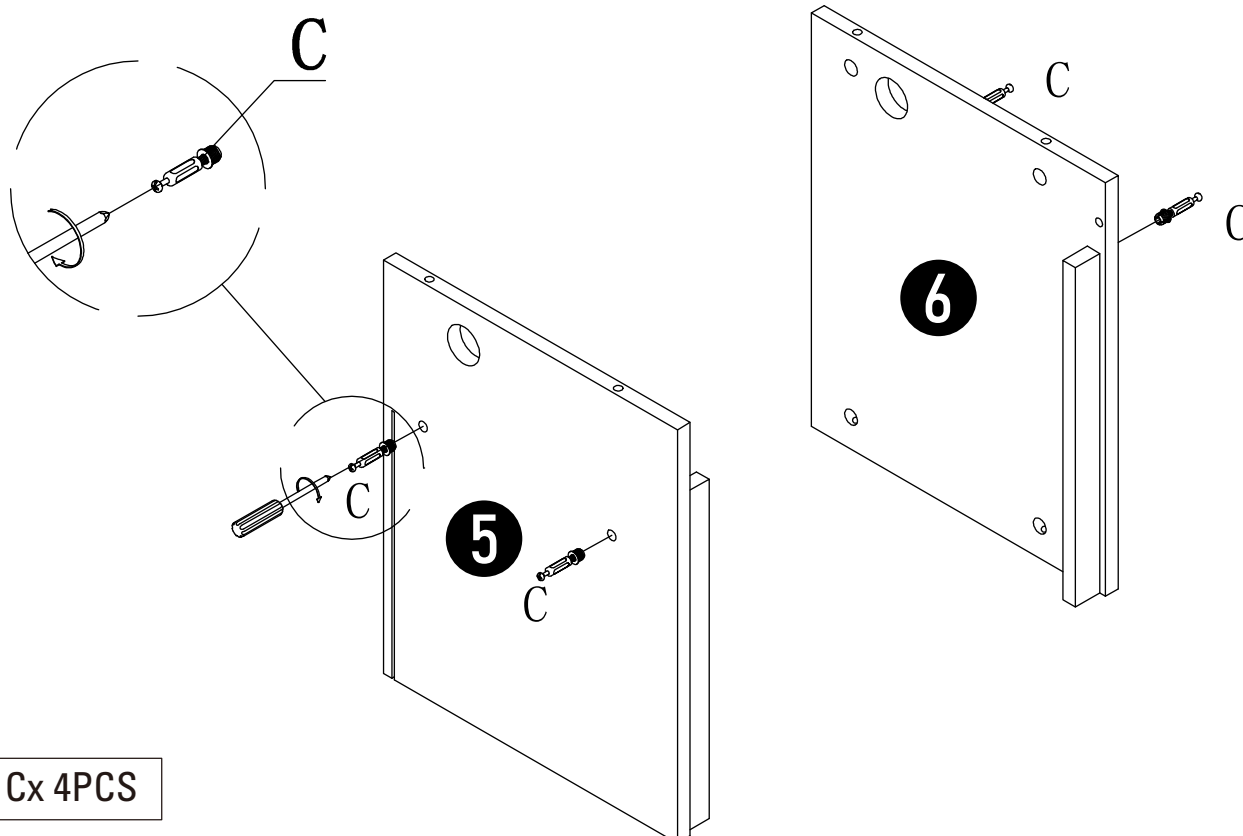

	Cx 4PCS
-------------------------------------------------------------------------------------	---------

PRODUCT ASSEMBLY

STEP 9

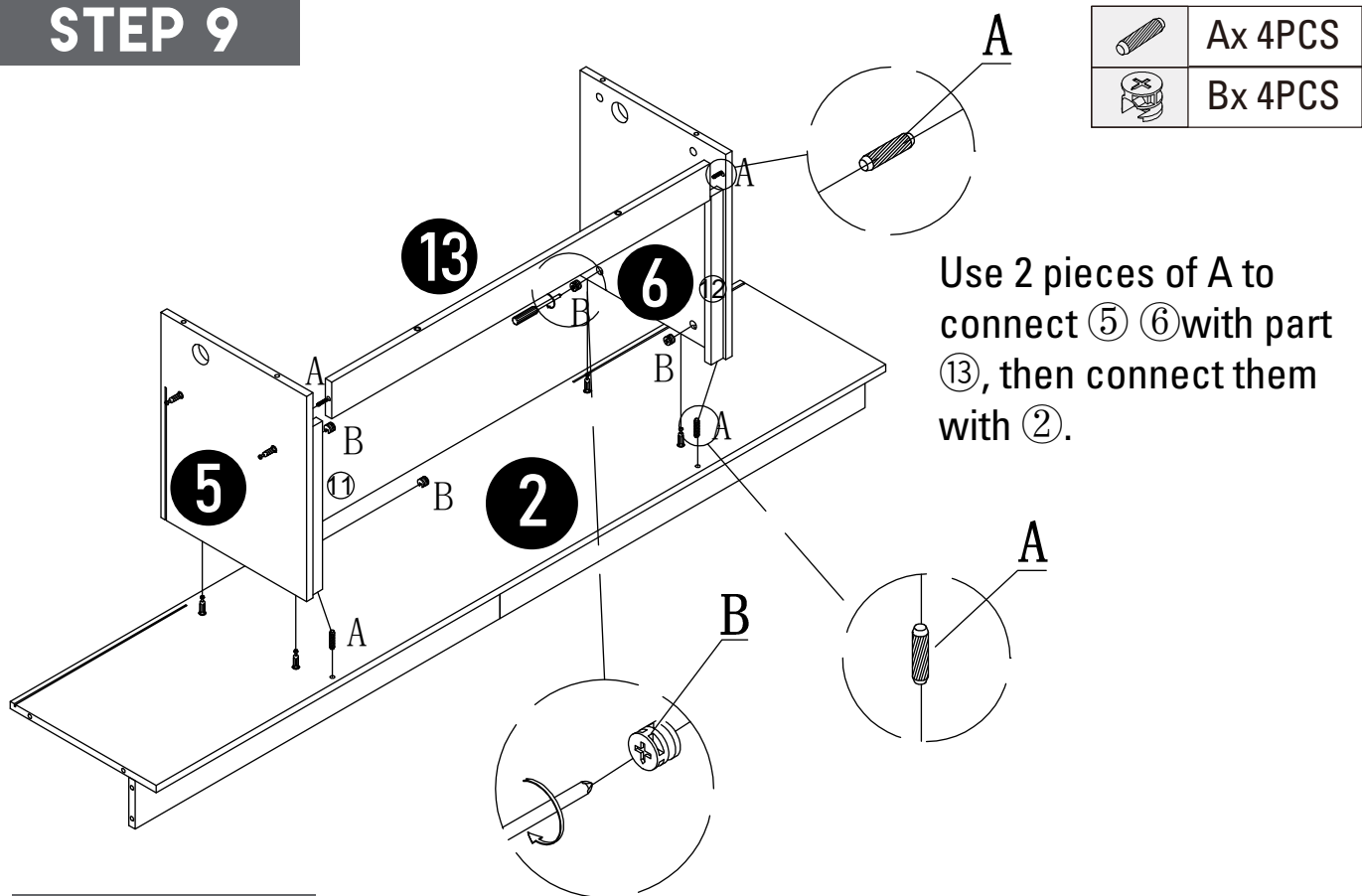

STEP 10

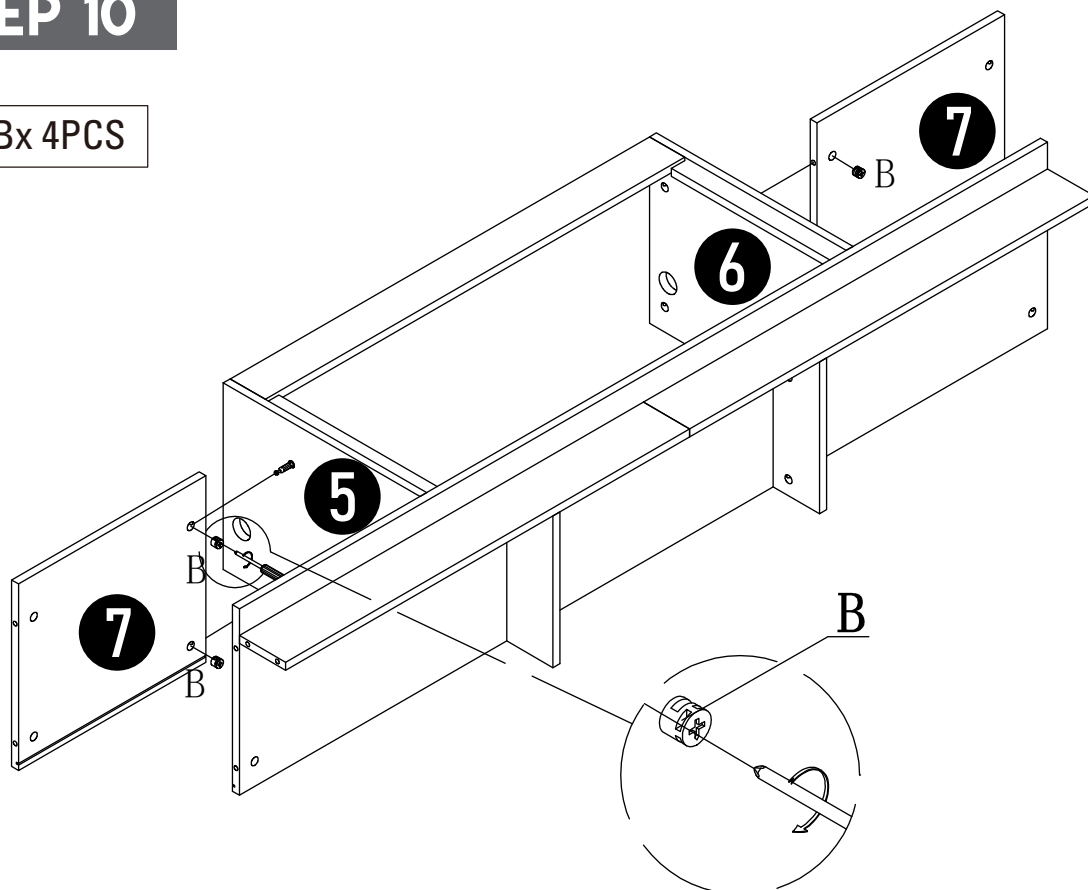

PRODUCT ASSEMBLY

STEP 11

Slide part ⑭ all the way along the grooves of ⑦ and ②, making sure it snaps into the slot of ⑤ and ⑥.

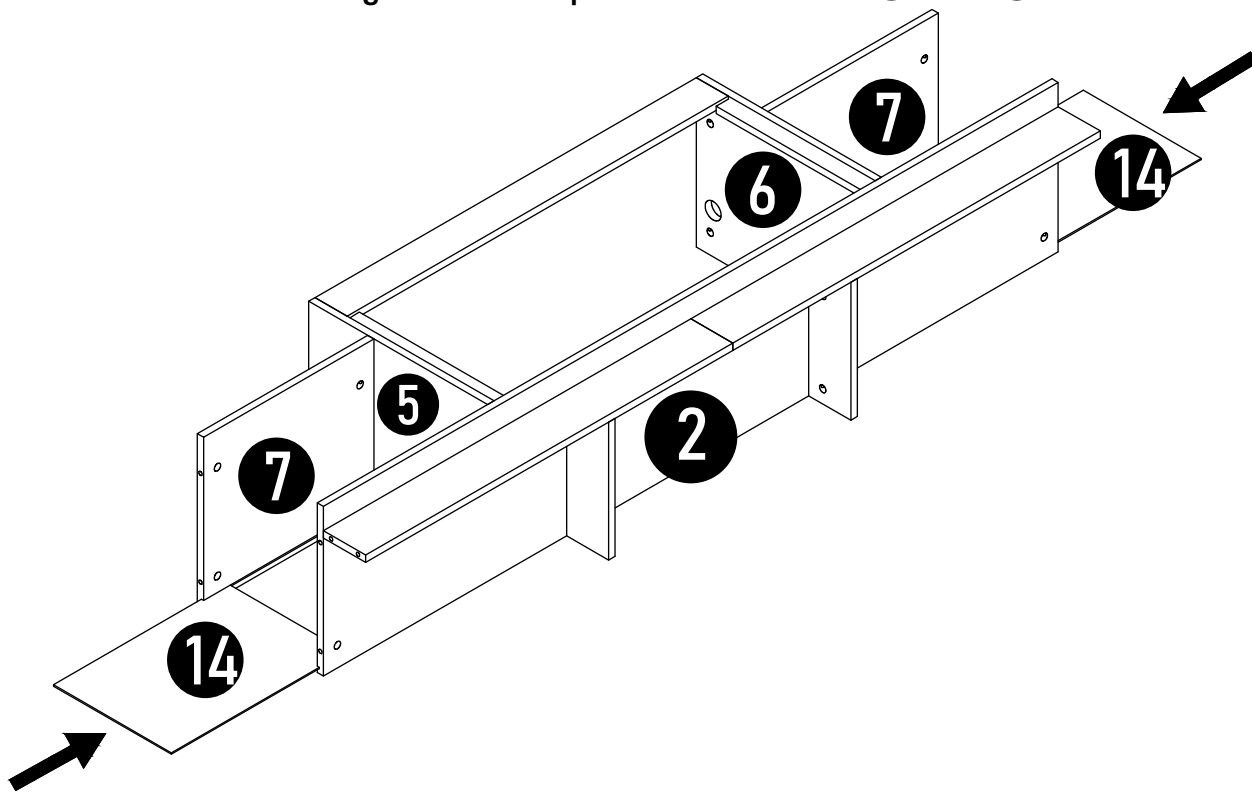

STEP 12

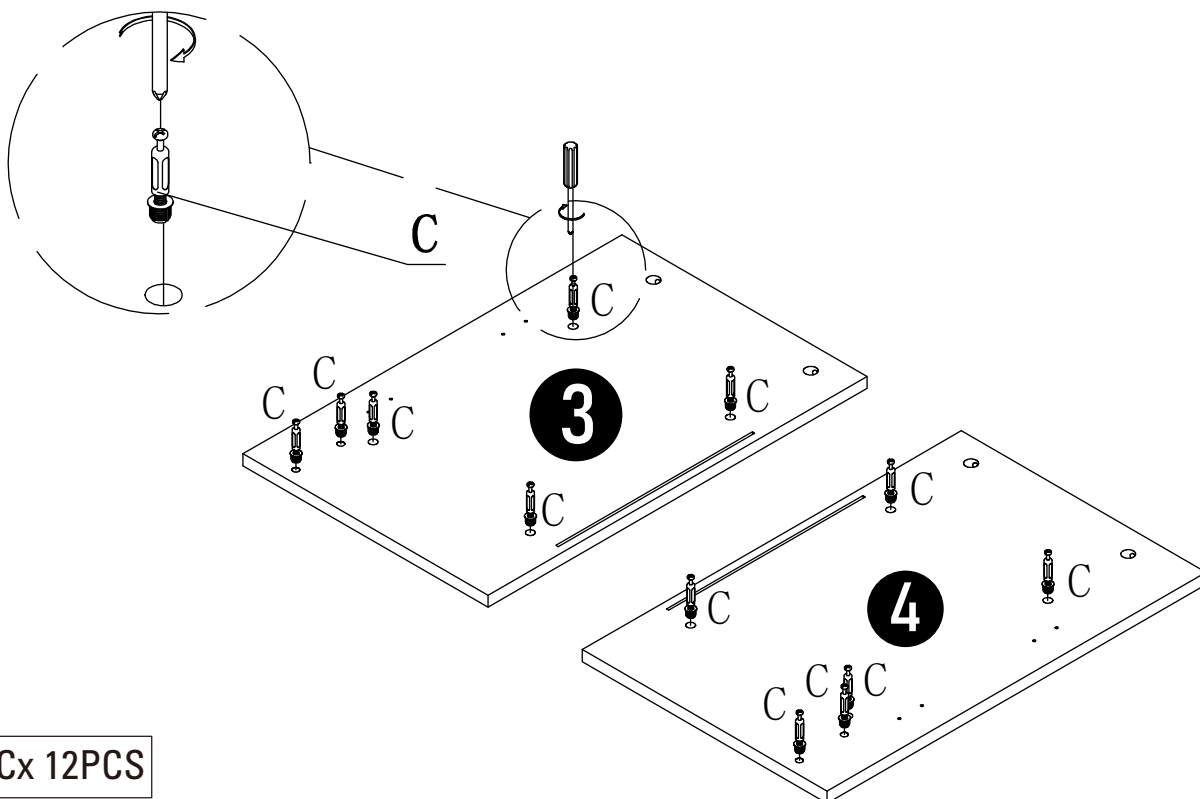

 Cx 12PCS

PRODUCT ASSEMBLY

STEP 13



Bx 12PCS

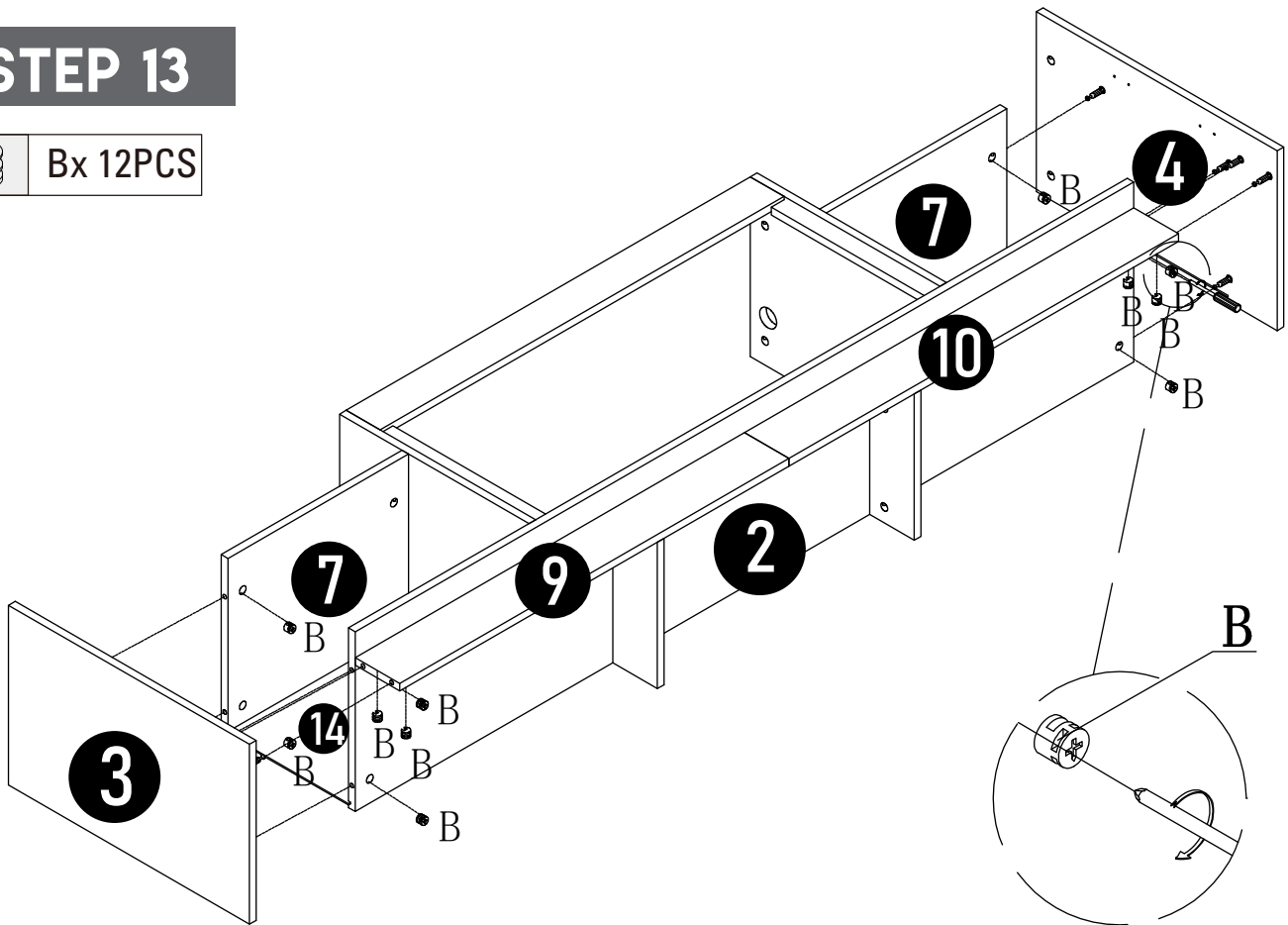

STEP 14



Cx 10PCS

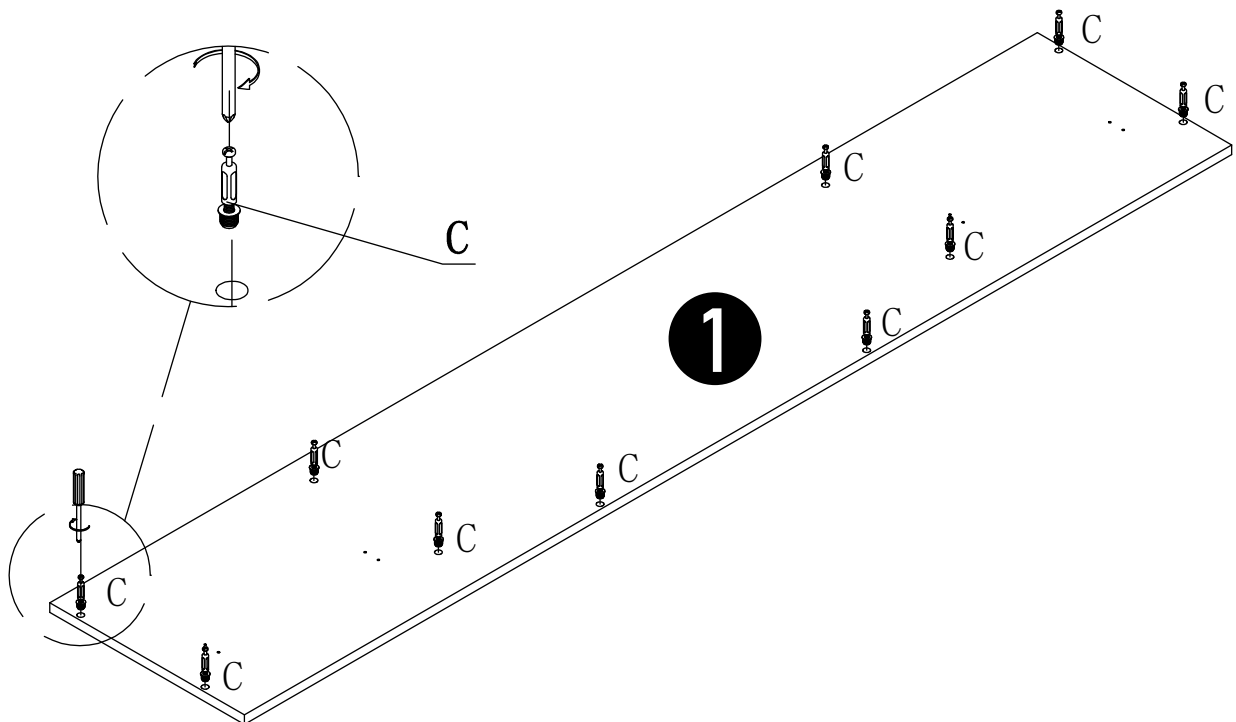

PRODUCT ASSEMBLY

STEP 17

First, install one pair of part D onto door (part ⑧). Then, install the other door panel in the same way.

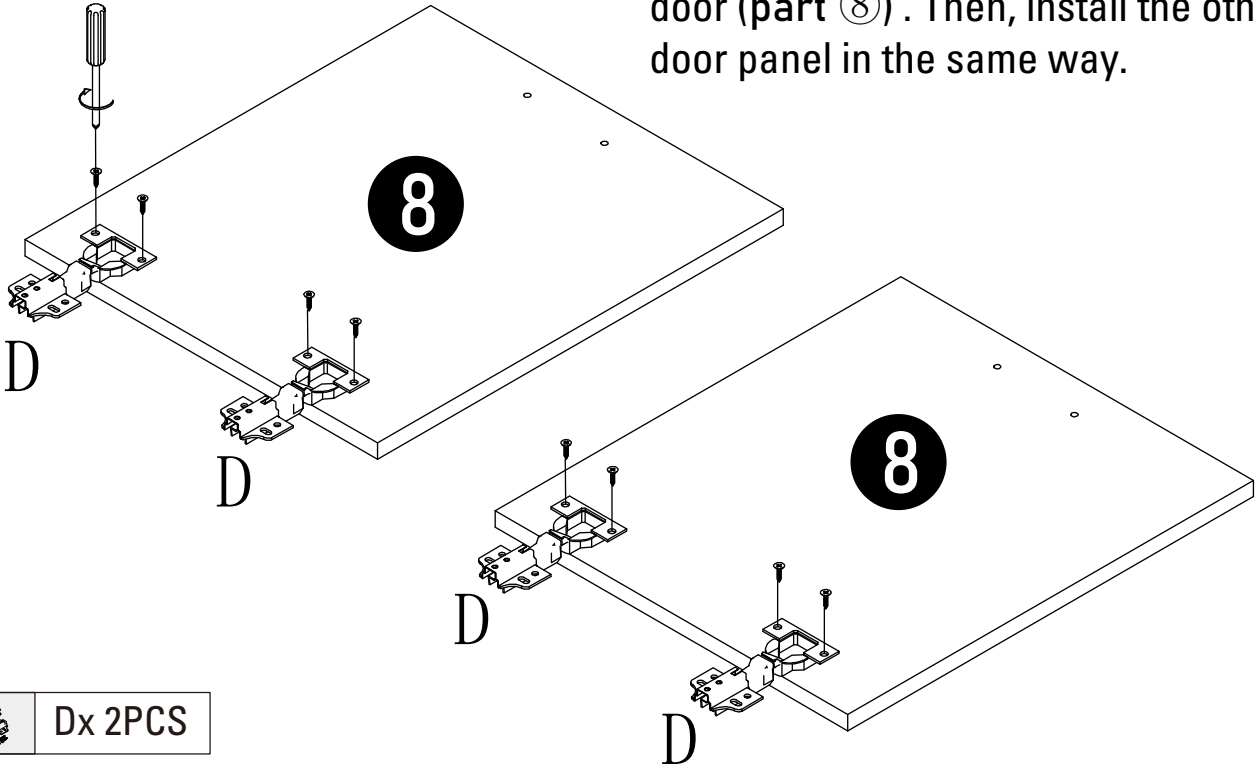

 Dx 2PCS

STEP 18

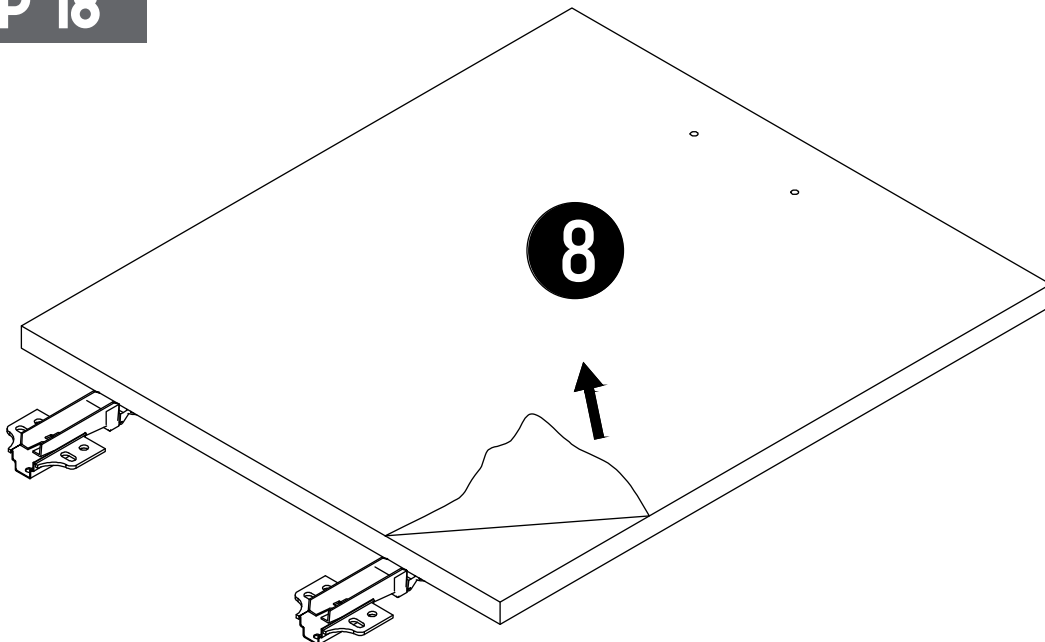



After installing part D, if the door has a protective film on the surface, peel it off from the front of ⑧. If there are any adhesive residues, you can simply wipe them off with a towel after the cabinet installation is complete. If there is no protective films, this step can be skipped.

PRODUCT ASSEMBLY

STEP 19

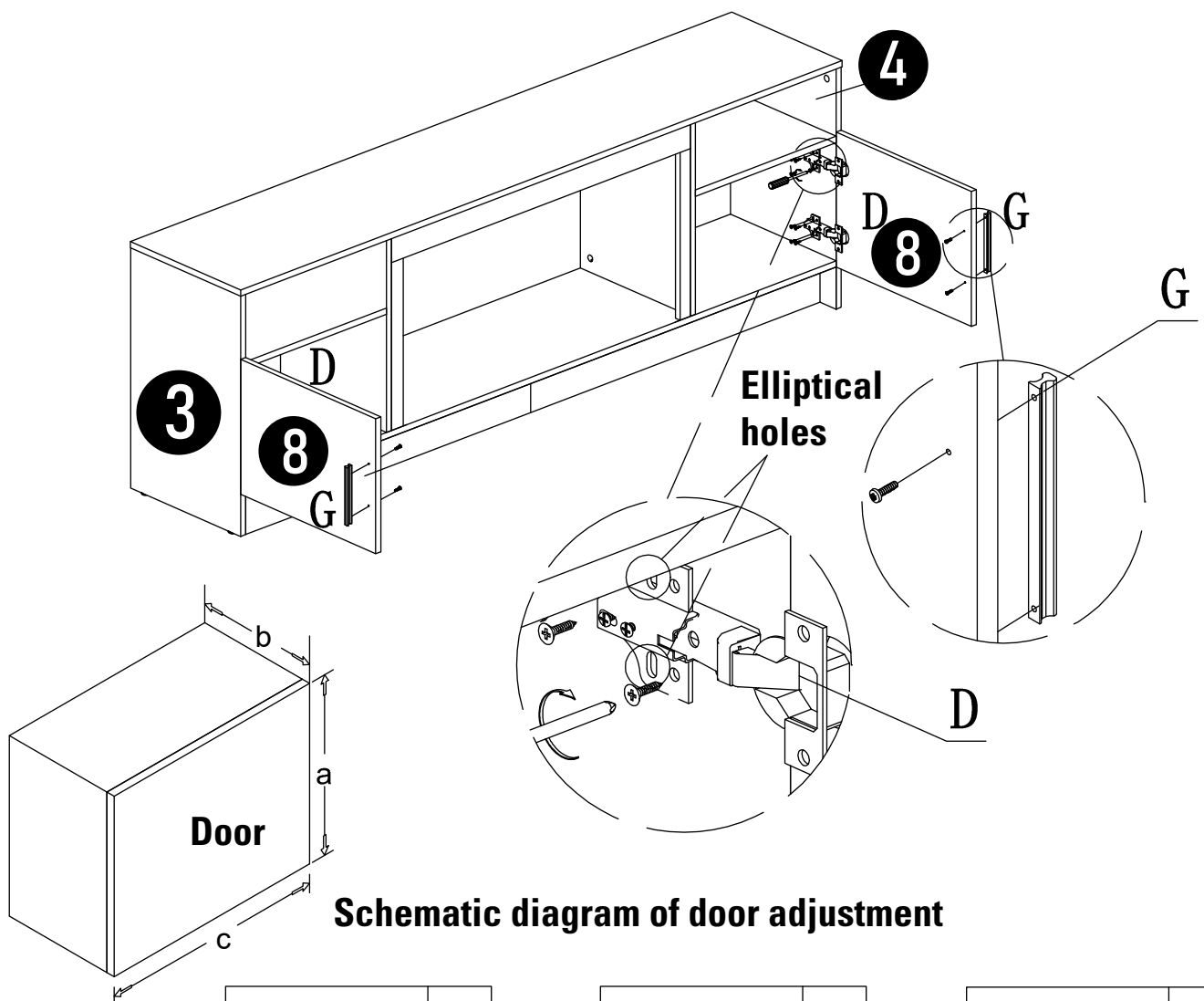
First, install one pair of part D onto ⑧. Then install part ⑧ onto part ③. When attaching doors, first secure the four screws in the oval holes of part D (these align with the four small holes on part ③). Close the door to check if its position is correct. If not, adjust the position according to the diagram. Once adjusted, tighten the four screws in the round holes of part D. Finally, install the other door part ⑧ onto part ④ in the same way.



	Dx 2PCS
	Gx 2PCS

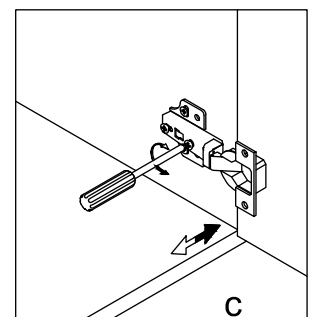
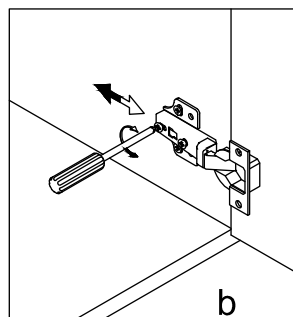
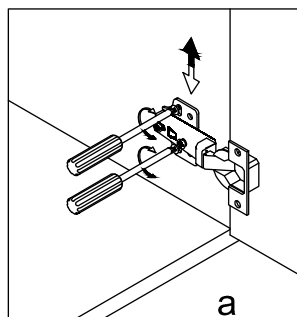

PRODUCT ASSEMBLY

STEP 20

Remove four silver screws from the sides of the heater, two screws on each side. Remove two screws from the front of the heater. Remove the tempered glass by lifting it from the lugs on the side.

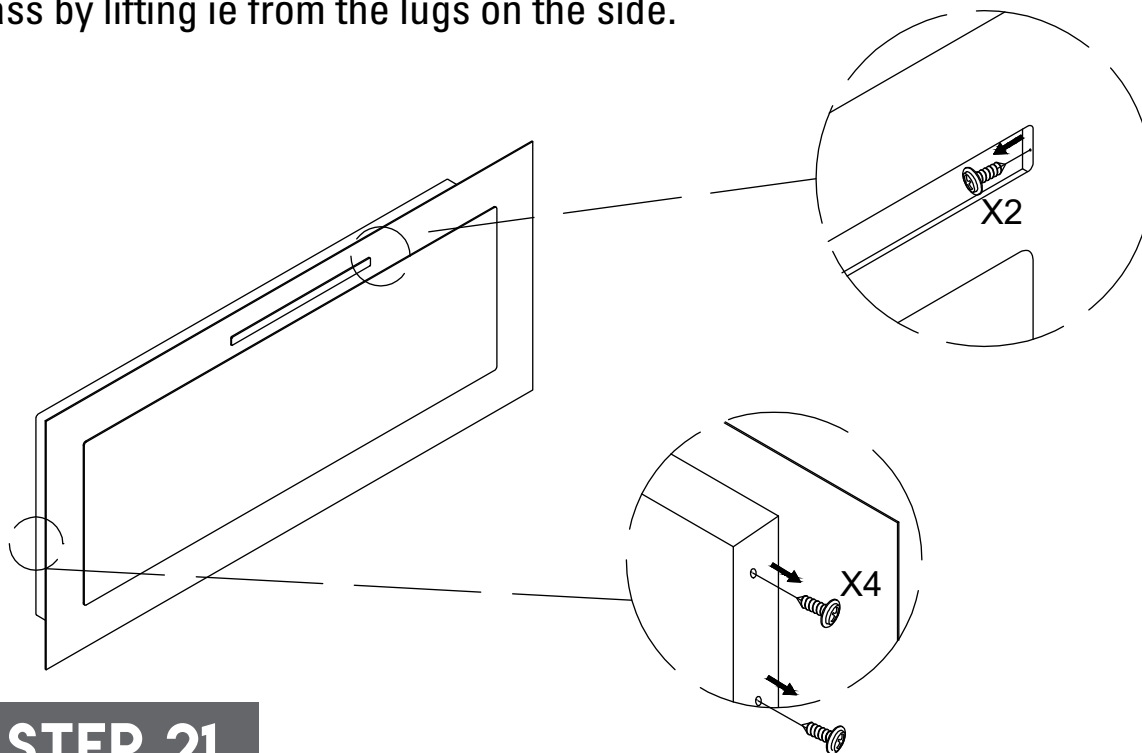

STEP 21

Take the glass from the appliance first, then gently put the appliance on the T Stand by two persons.

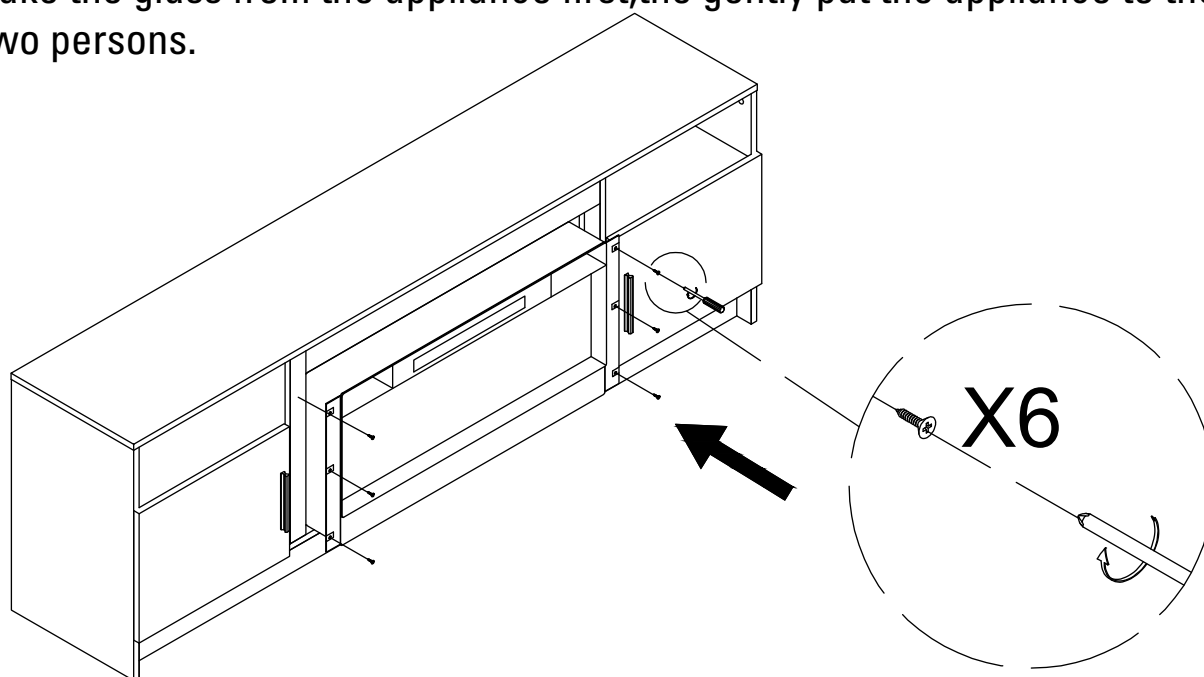

Fix the appliance to the TV stand with 6 black screws according to the hole position

PRODUCT ASSEMBLY

STEP 22

Place the front glass surround over the front of the fire aligning the slot in the bracket at each side of the glass panel with the lugs on the sides of the fire .

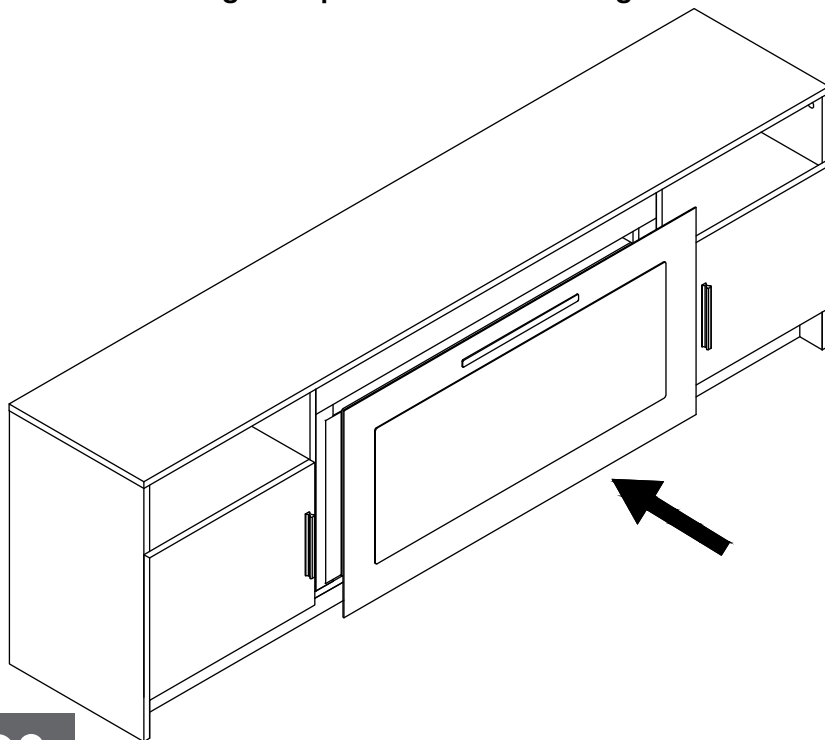

STEP 23

Fix the tempered glass with 2pcs of 4*8mm screws provided.

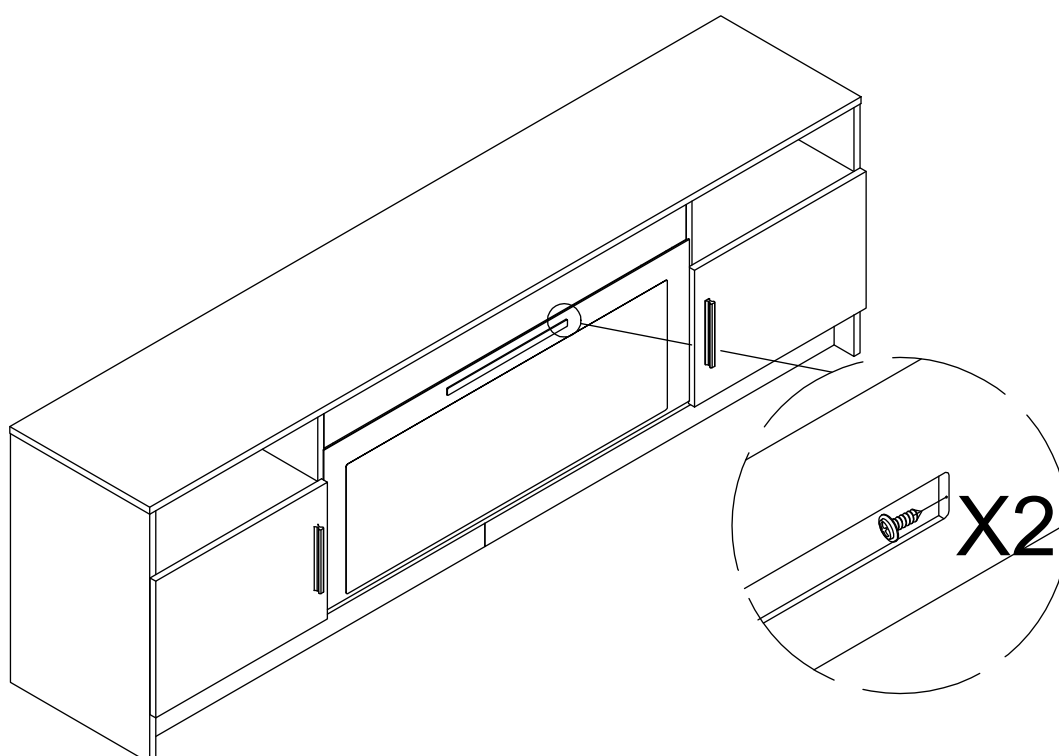

PRODUCT ASSEMBLY

STEP 24

Connect the lamp strip to the fireplace by threading it through holes ⑤ and ⑥.

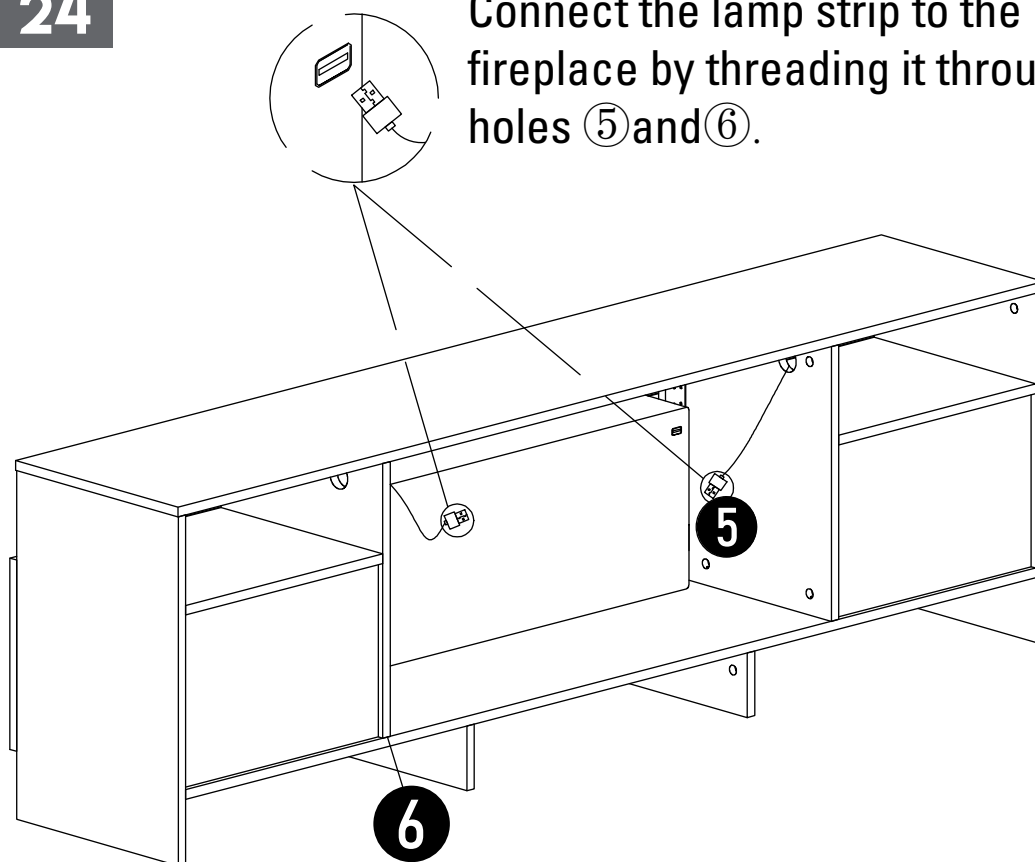

STEP 25

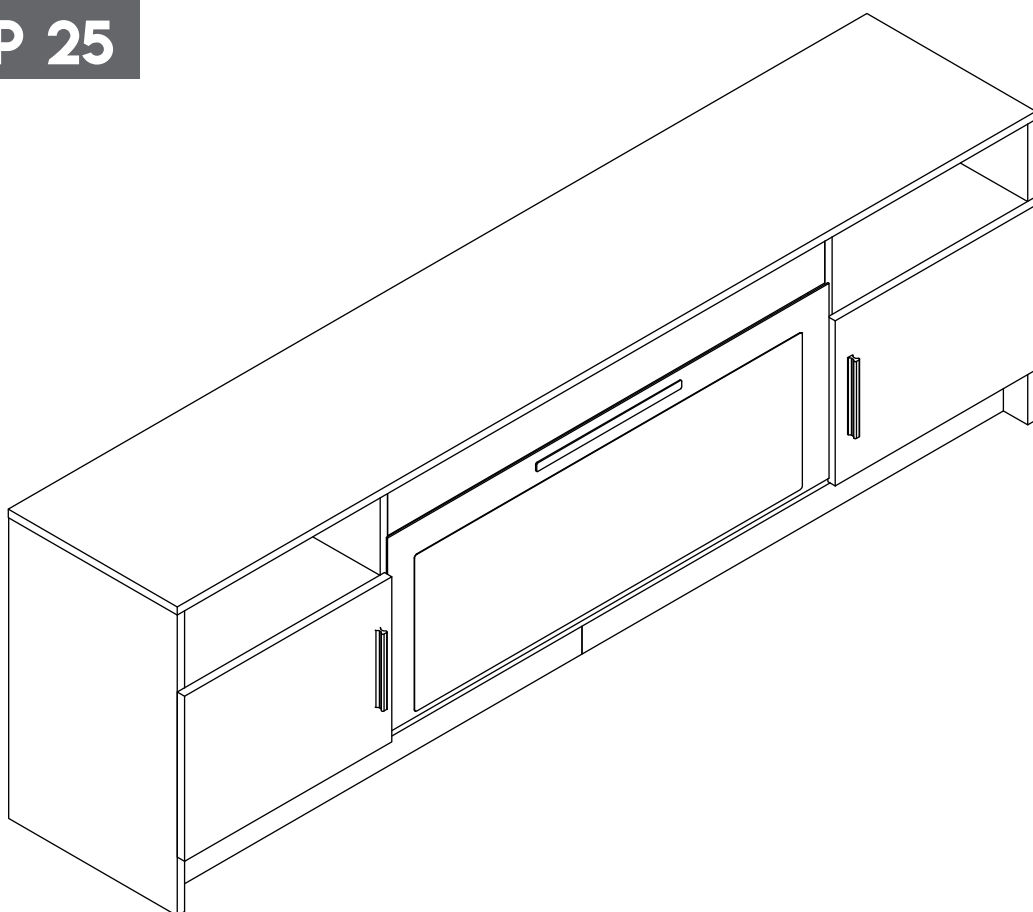

PRODUCT ASSEMBLY

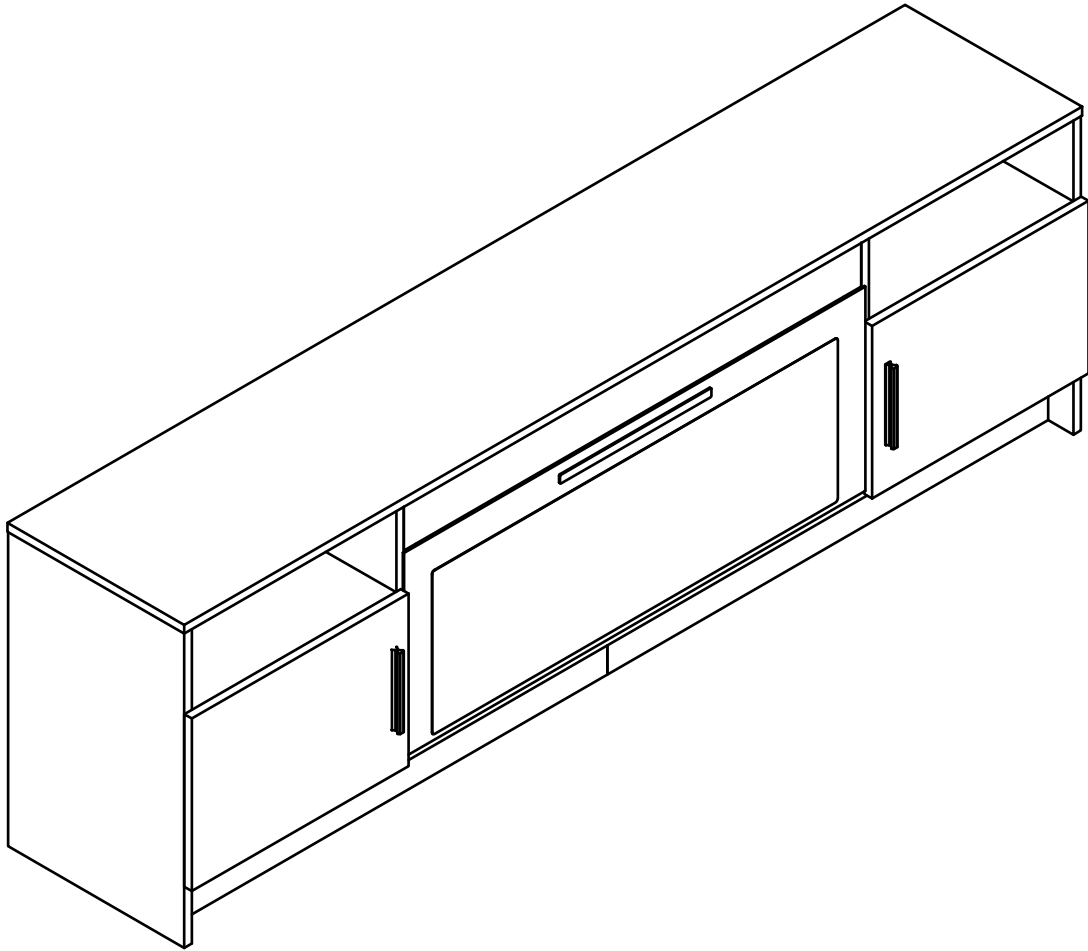

Final Check

1. Ensure all screws are tightened.
2. Verify that all panels are securely fitted.
3. Clean any dust or debris from the assembly process.

Your TV stand is now successfully assembled and ready for use! We hope you enjoy your new TV stand! If you're happy with the result, we'd love to see how it looks in your space. Share a photo of your setup and inspire others with your creativity. Your experience help us continue improving our products!

HELP CENTER

Question about your product? We're here to help. Visit us at:

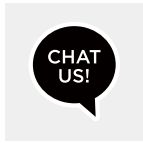

Chat Support



Product inquiry

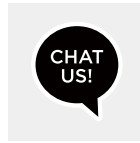

Orders FAQ

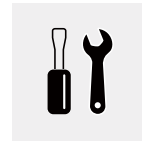

Product Assembly



Returns & Refunds

WE STAND BEHIND THE QUALITY OF OUR FURNITURE

1. If you have any issues with your item, please let us know! We will always do our best to come up with a solution that you will be happy with.
2. Please get in touch with our customer service team before returning the product.
3. And please do not throw away the original box(es) if you have not finished assembling and confirmed no quality issues.

Length of return period:

You can return items within 30 days of purchase

In the meanwhile, everything you purchased from us comes with a one-year warranty.

Who is responsible for the return shipping fee:

We will cover the return shipping fees if:

1. Your item has a manufacturing defect in materials or workmanship. For example, torn wicker or misaligned screw holes. We will send you a prepaid shipping label after you send us photos or videos of the defect.
2. Your item has been damaged in transit. For example, glass is broken or product is damaged. We will send you a prepaid shipping label after you send us photos of the damage.
3. You receive the wrong box(es) due to a warehouse error. We will send you a prepaid shipping label after you send us photos of the wrong SKU numbers on the outer box(es).
4. One or more boxes are lost in transit. We will send you a prepaid shipping label if you no longer want the item.

* However, we still hope to work with you for a better solution instead of a return.

Please don't hesitate to contact our customer service team.

Customer will cover the return shipping fees if:

- 1.You don't like the product(s) after receiving the box(es).
- 2.You no longer need the product(s) but have received the box(es).
- 3.You buy the product(s) by mistake but have received the box(es).
- 4.Order/shipment cancellation failed, and you have received the box(es).

Return Request

In order to get a full refund as described in this return policy, all items must be:

- 1.In a brand new/unused condition. Please provide photos before and after packaging.
- 2.When returning, all accessories and parts must be firmly packed in all original packaging. If your return does not meet these requirements, you may not receive a full refund.

When will I be refunded?

The refund is issued once the goods have been returned to our warehouse.

What if the product is damaged/defective outside of the valid return period?

We want you to be a happy customer. Please reach out to us via email, and we will work on a solution to ensure your satisfaction.

HELP CENTER

Please feel free to **send us the text**. We will reply to you within 24 hours. Also please feel free to contact us if you have received the defective items.