

Features

- VibrAcoustic calms and soothes with sound vibration technology.
- Six concealed speakers send sound waves through the water to gently massage the body.
- Six original instrumental compositions offer different levels of relaxation.
- Syncs with devices enabled with BLUETOOTH® wireless technology including smartphones, MP3 players, tablets, and laptops located up to 33 feet away.*
- Customize your experience with the high-resolution color touch screen.
- Fully-adjustable volume above and below the water.
- Functions as a hydrotherapy bath when full of water and a stereo system when empty.
- Includes 25' of wiring and amplifier.
- Freestanding design creates a striking focal point in your bathing area.
- Integral lumbar support.
- Slotted overflow allows for deep soaking.
- Coordinates with other products in the Archer collection.

Material

- Acrylic.

Installation

- Reversible drain.
- Freestanding.
- End ledge allows for deck-mounting capabilities for faucets.

Required Products/Accessories

K-7271 Brass Slotted Overflow Bath Drain

or

K-7272 PVC Slotted Overflow Bath Drain

Recommended Products/Accessories

K-23726 Drain treatment

K-23732 Tub & shower cleaner

Included Components

Additional Components:

25' (7.6 m) cables



Codes/Standards

CSA B45.5/IAPMO Z124

UL 1795

CSA C22.2 No. 218.2

EPA TSCA Title VI





KOHLER® Plastic Baths and Receptors Lifetime Limited Warranty

See website for detailed warranty information.

The BLUETOOTH® word mark and logos are registered trademarks owned by Bluetooth SIG, Inc. and any use of such marks by Kohler Co. is under license. Other trademarks and trade names are those of their respective owners.

Available Colors/Finishes

Color tiles intended for reference only.

Color	Code	Description
	0	White
	47	Almond
	NY	Dune
	G9	Sandbar

No change in measurements if connected with drain illustrated. (K-7272)

☐ Recommended Faucet Location

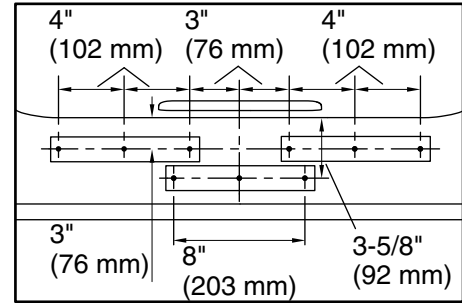
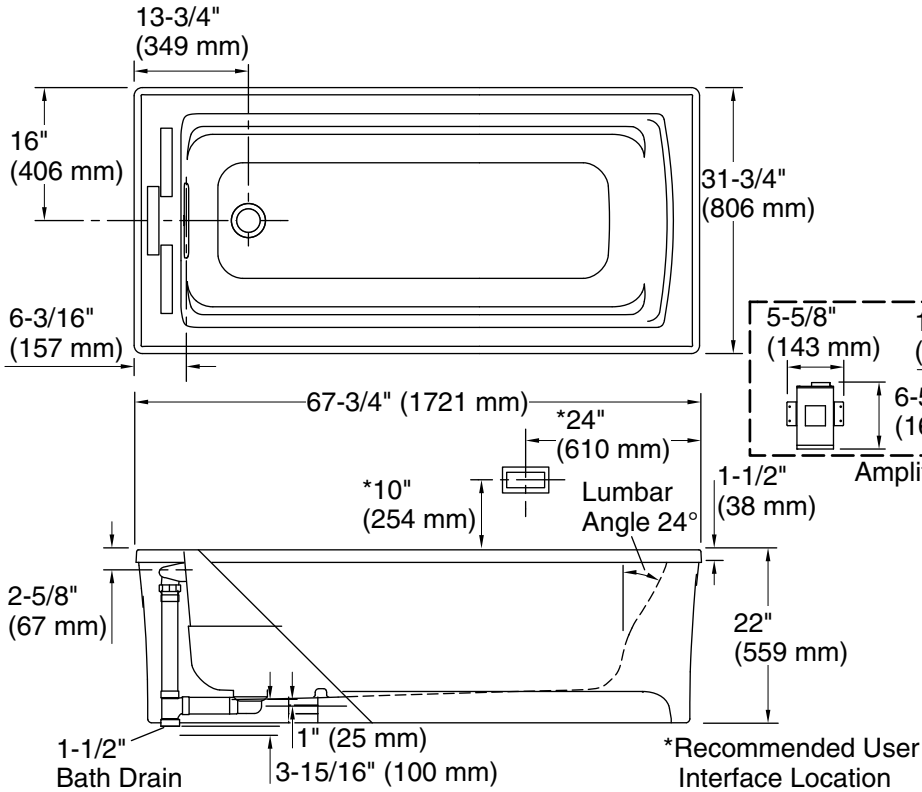

Recommended Faucet Hole Location

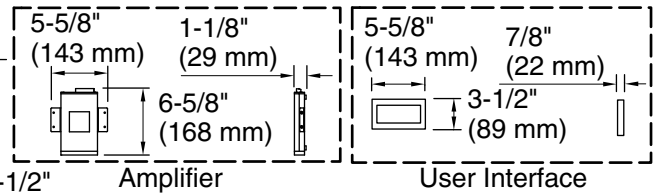

Amplifier

User Interface

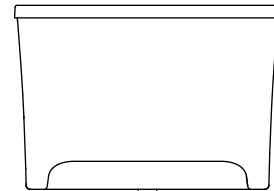

Required Electrical Service

One dedicated circuit required, protected with Class A Ground-Fault Circuit-Interrupter (GFCI). Outside North America, this device may be known as a Residual Current Device (RCD).

Amplifier: 120 V, 15 A, 60 Hz

Technical Information

All product dimensions are nominal.

Installation: Freestanding

Drain location: End

Basin area, bottom: 51-1/16" x 19-11/16" (1297 mm x 500 mm)

Basin area, top: 58-9/16" x 25-5/16" (1487 mm x 643 mm)

Weight: 174 lbs (78.9 kg)

Minimum floor load: 43.6 lbs/ft² (212.9 kg/m²)

Water depth: 15-1/16" (383 mm)

Water capacity: 65 gal (246.1 L)

Template: Footprint, 1265461, not required, not included

Electrical component rating: Amplifier: 120 V, 10 A, 50/60 Hz

Amplifier channels: 2 at 15 W per channel

1-800-4KOHLER (1-800-456-4537)

Kohler Co. reserves the right to make revisions without notice to product specifications.

For the most current Specification Sheet, go to www.kohler.com.

5-29-2021 17:36 - US//CA

Notes

Measure your actual product for rough-in details.

Install this product according to the installation instructions.

The hot water supply should be 70% of the capacity of the bath or greater. Installations will vary.

Control amplifier fits 16" (406 mm) center studs.

Provide a separate grounded outlet if connecting to a powered wireless device or adapter.

If installing a rim-mount faucet, make sure there is no interference above or below the deck before drilling any holes.

IMPORTANT! Due to BLUETOOTH signal overlap, installations of multiple baths within 50 ft (15.2 m) of each other will require special order product. Please contact your dealer, showroom, or sales representative for ordering assistance.