

Assembly Instructions

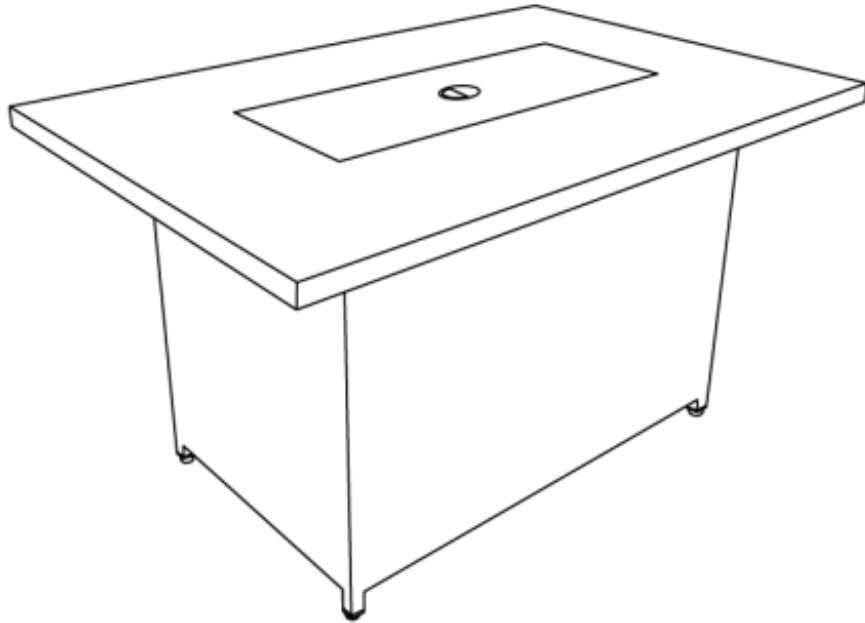

Assembly
video



For any missing hardware, damaged parts and other problems.
WELCOME to email us at: **service@behousewell.com**

Or call at 1-833-474-1928 Toll free
Between 9AM and 5PM Eastern time, Monday through Friday

***Don't fully tighten all the bolts till the very end!**

PRE-ASSEMBLY PREPARATION:

- A cordless drill is recommended for ease of assembly.
- Clear out the space for assembly and lay out all of the parts based on the Parts List, extra room will allow you to easily determine if all the pieces are present.
- Keep small parts and pieces away from children until fully assembled.



A

Table top
1pc

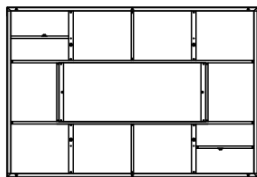

D

Side panel
1pc

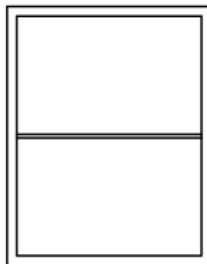

G

Support bar
3pcs

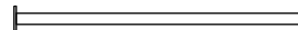

B

Front
1pc

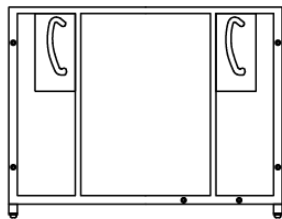

E

Side bar
1pc

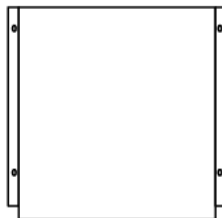

E

Table base
1pc

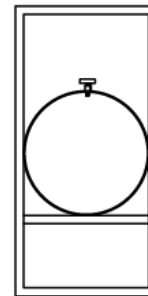

C

Back
1pc

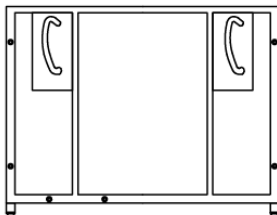

F

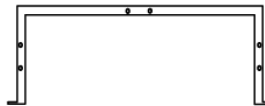

Support bar
2pcs

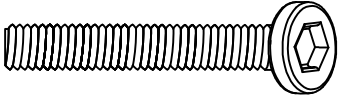
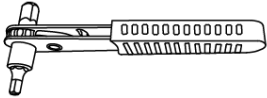
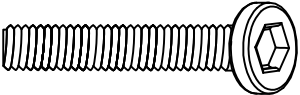
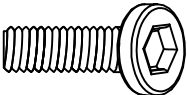
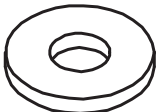
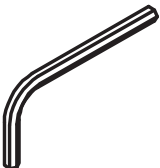

No.	Part/Size	QTY	Image	No.	Part/Size	QTY	Image
I	Bolt (M6*35mm)	4	<p>**Actural Scale</p> 	N	Wrench	1	
J	Bolt (M6*30mm)	8	<p>**Actural Scale</p> 				
K	Bolt (M6*15mm)	16	<p>**Actural Scale</p> 				
L	Washer	28					
M	Allen Wrench	1					

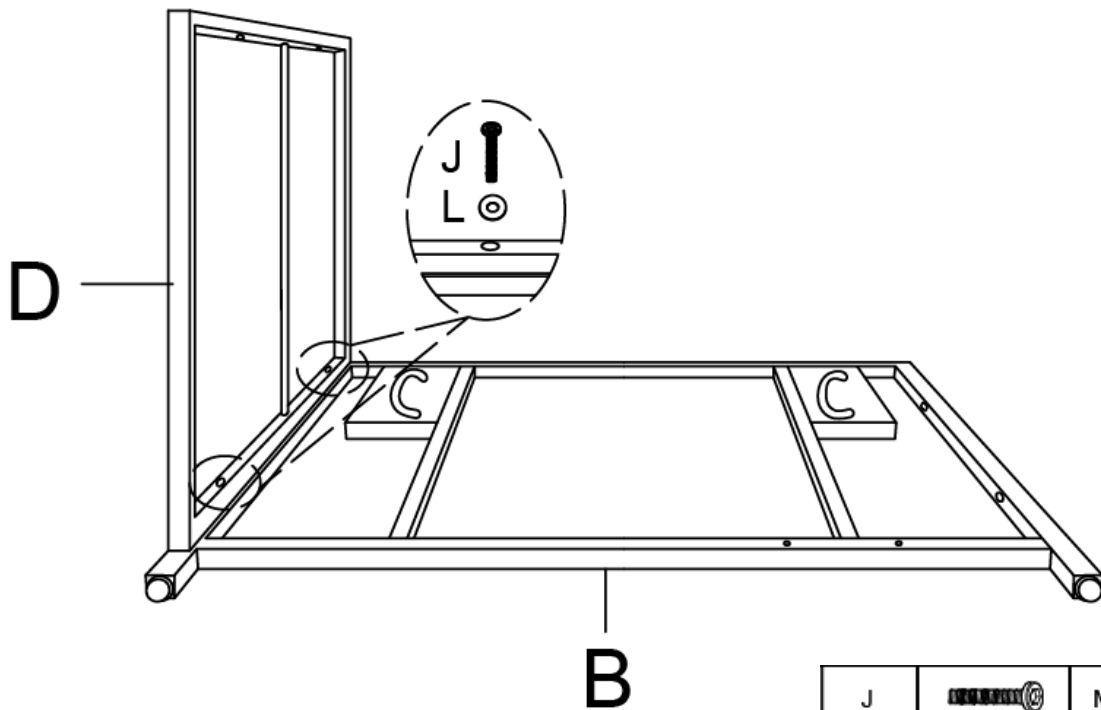

Step 1 : Attach B&D to each other with 2 washers (L), and 2 screws (J) by using allen wrench (M/N). Do not tighten all screws now.



J		M6*30	2
L		Ø16*Ø6.5*1	2

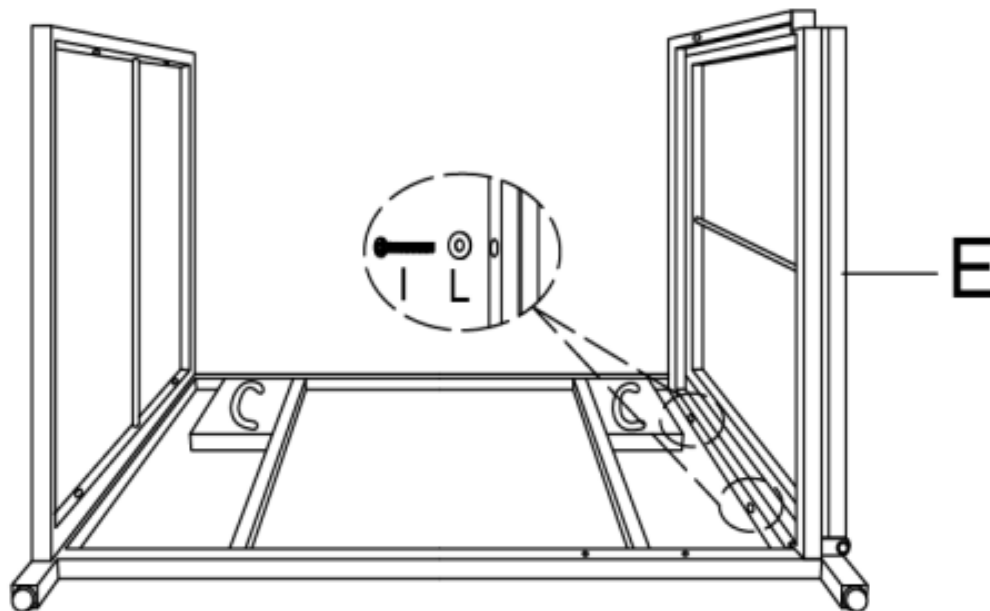

Step 2 : Secure E to assembled B&C with 2 washers (L) and 2 screws (I) by using allen wrench (M/N). Do not tighten all screws now.

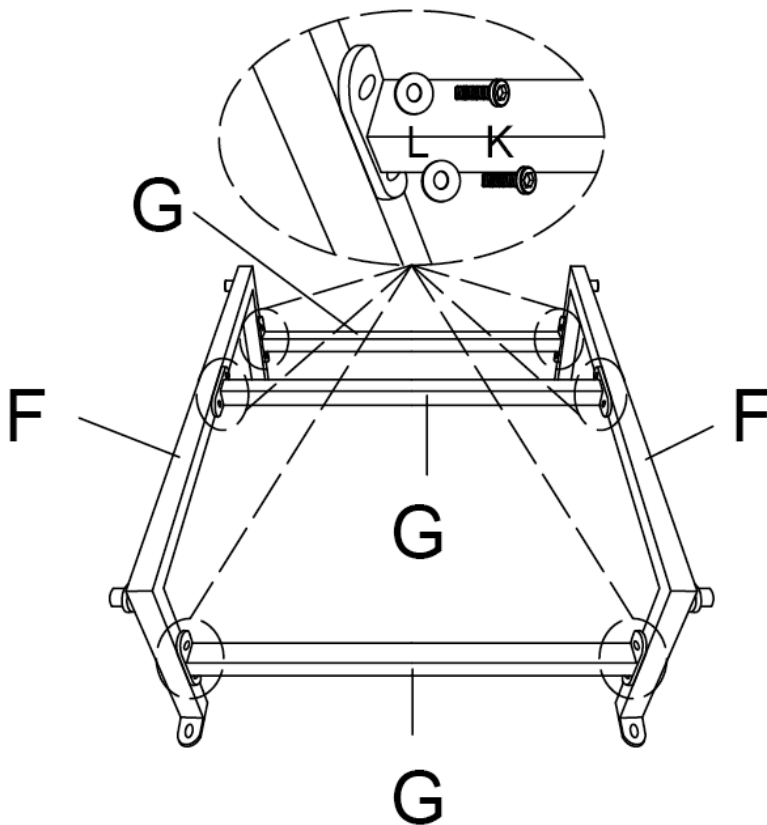

I		M6*35	2
L		Ø16*Ø6.5*1	2

Step 3 : Attach G&F to each other with 12 washers (L), and 12 screws (K) by using allen wrench (M/N). Do not tighten all screws now.





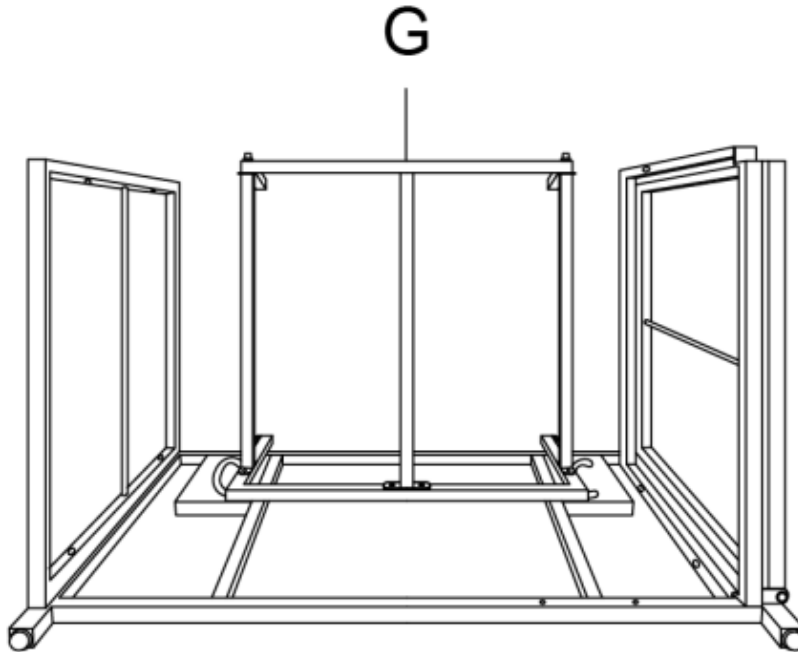

K		M6*15	12
L		Ø16*Ø6.5*1	12

Step 4 :Attach F to B.

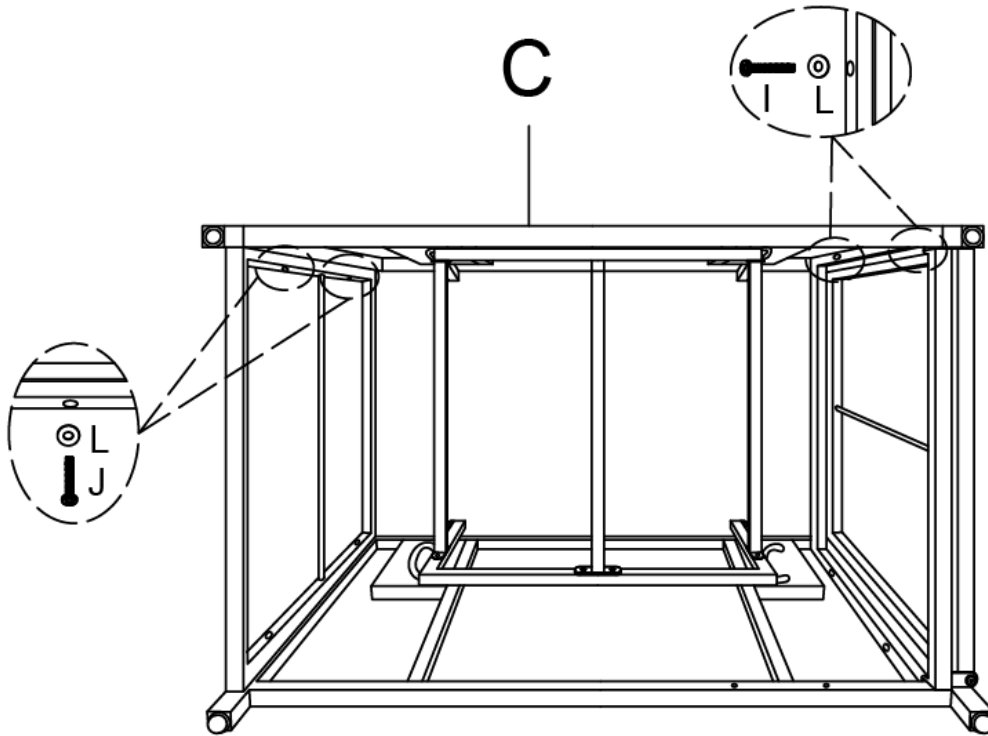

Step 5 :Secure C to assembled G and assembled E with 4 washers (L), 2 screws (J) and 2 screws (I) by using allen wrench (M/N). Do not tighten all screws now.



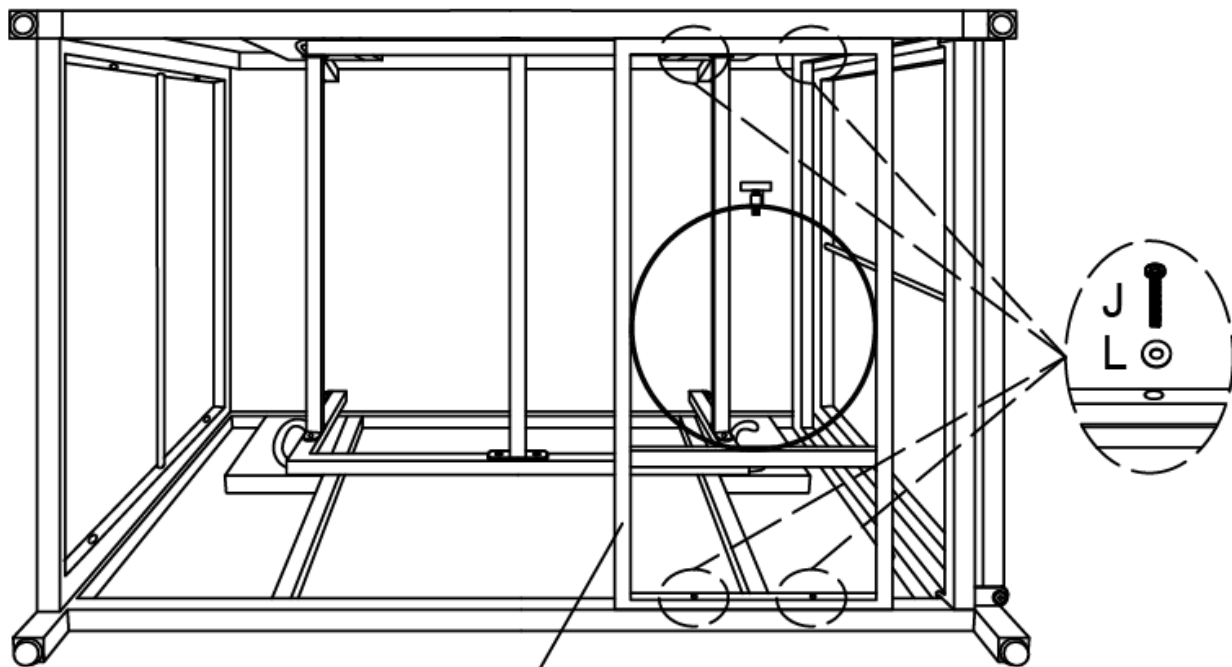

I		M6*35	2
J		M6*30	2
L		Ø16*Ø6.5*1	4

Step 6 :Secure H to assembled B with 4 washers (L), 4 screws (J) by using allen wrench (M/N). Do not tighten all screws now.





H

J		M6*30	4
L		Ø16*Ø6.5*1	4

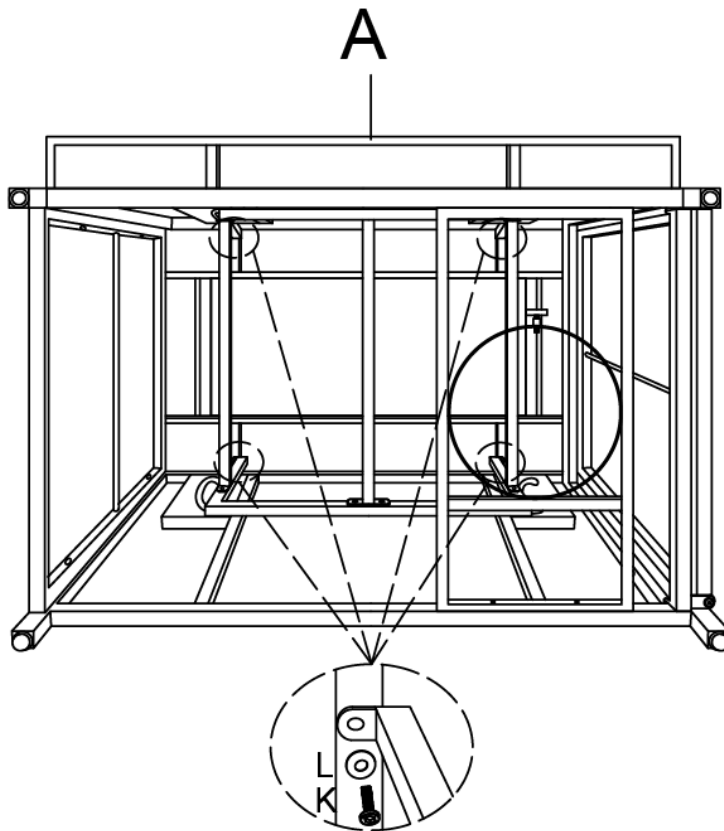
Step 7 Secure A to above assembled parts with 4 washers (L) and 4 screws (K) by using allen wrench (N/M). fully tighten all screws now.



K		M6*15	4
L		Ø16*Ø6.5*1	4

Step 8 :Secure A to B&C.

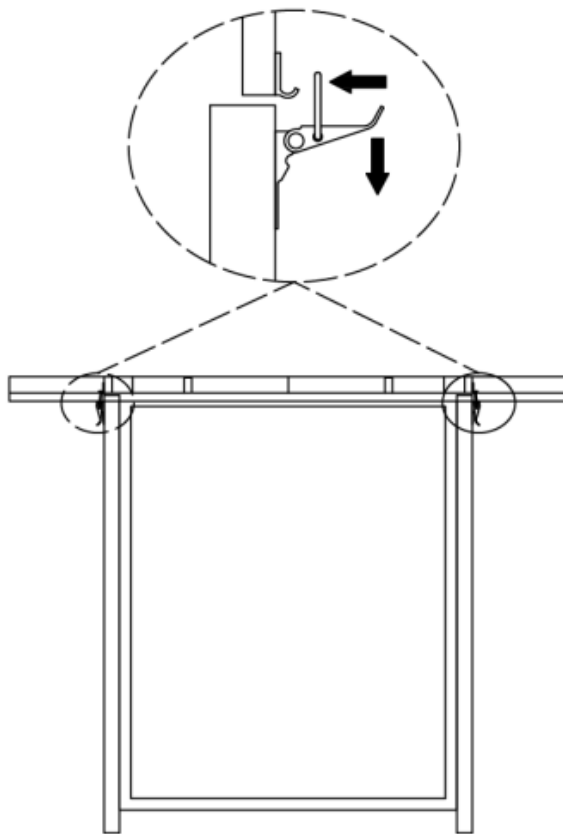

Step 9 : Table is ready to use now.

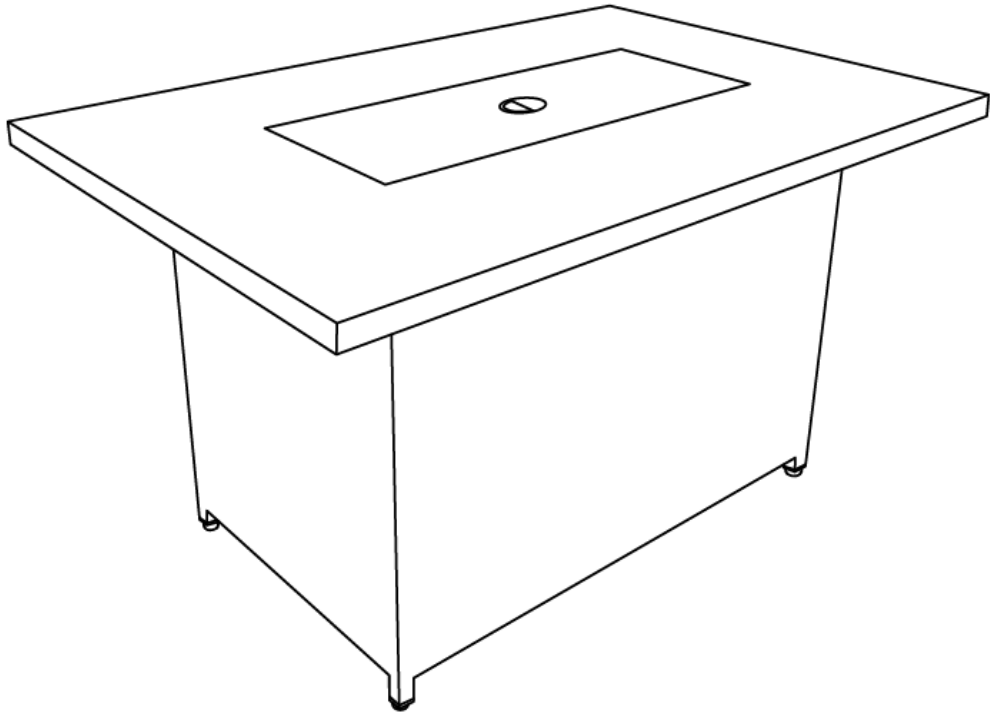

Place the gas cylinder into the cylinder holder (figure 1), secure the cylinder by tightening clockwise the bolt (figure 2) found on the cylinder holder, so the cylinder cannot move from side to side or fall down.

The knob on the control panel is turned all the way to the "OFF" position (figure 3) when the fire pit is not in use.

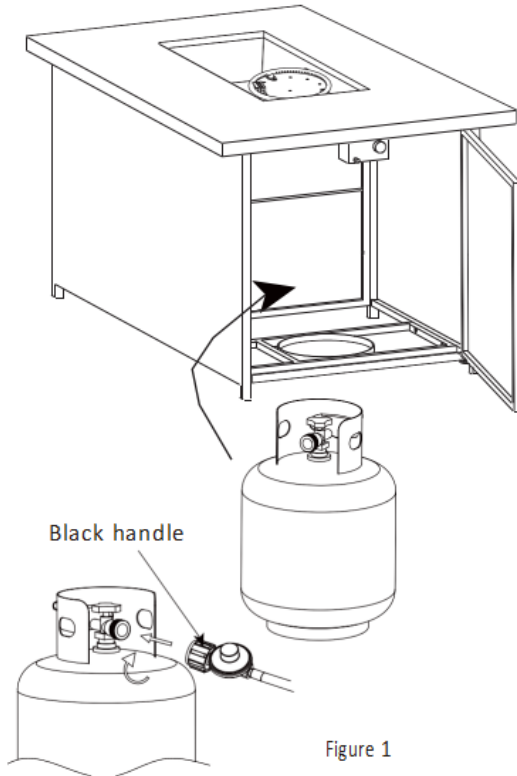

Figure 1

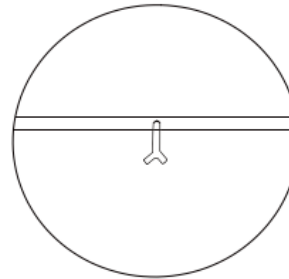

Figure 2

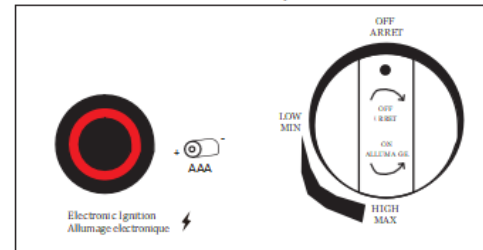

Figure 3

BATTERY

Make sure the control knob is in the “OFF” position. Unscrew the push button cap on the ignitor module located on the control panel to access the battery compartment. The ignitor module requires one +AAA size battery. BATTERY IS NOT INCLUDED. (See Figure 4).

WARNING:

- Please observe proper polarity and use the correct battery type when placing or replacing the battery. Improper installation could result in ignition failure.
- Please remove the battery if consumed or if product is to be left unused for a long period of time.

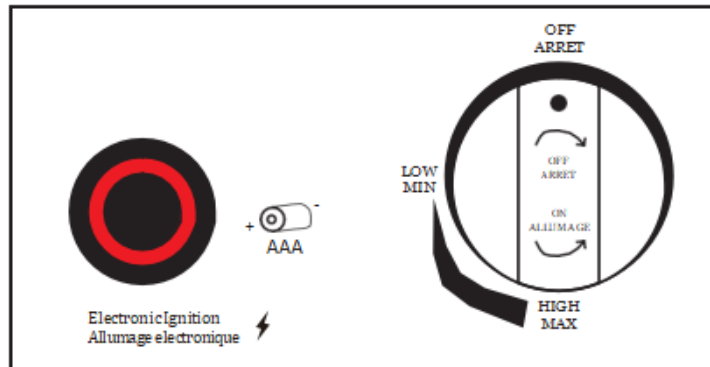
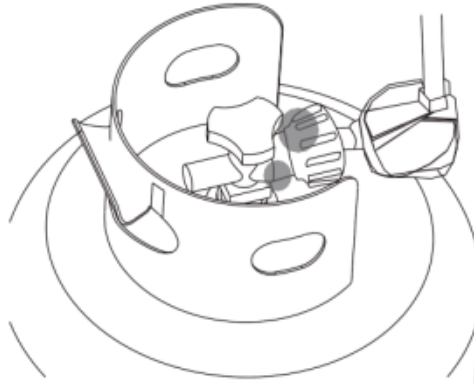

Figure 4

LEAK TEST

To prevent fire or explosion hazard when testing for a leak:

1. Always perform the leak test as described below before lighting this appliance or each time the cylinder is connected for use.
2. Do not smoke or allow other sources of ignition in the area while conducting a leak test.
3. Conduct the leak test outdoors in a well-ventilated area.
4. Do not use matches, lighters or a flame to check for leaks.
5. Do not use this appliance until any and all leaks are corrected. If you are unable to stop a leak, disconnect the propane supply. Call a gas appliance service shop or your local propane gas supplier.



cylinder-regulator connection (Figure 5)

To perform a leak test:

1. Make 2~3 oz. of leak solution by mixing one part liquid dish washing detergent and three parts water. Noted: make sure control knob is “OFF”.
2. Apply several drops of solution where the cylinder attaches to regulator (See Figure 5), inspect the solution at the connection looking for bubbles. If NO bubbles appear, the connection is secure. If bubbles appear, the connection has the leak, disconnect the regulator, reconnect, perform another leak check. If you continue to see bubbles after several attempts, cylinder valve is defective and should be returned to cylinder’s supplier.

LIGHTING INSTRUCTIONS

1. Push in gas control knob slightly and turn to “OFF”.
2. Turn gas control knob the “ON/HI”.
3. Push in gas control knob all the way and hold. Continue to press the ignition button for 15 seconds.
4. If the burner does not light in 15 seconds, release the knob and it will pop back out. Wait 5 minutes before attempting to light the burner again, repeat step 1 to 3.

TO TURN OFF GAS

1. Push in gas control knob slightly and turn to “OFF”.

WARNING: For your safety, read and follow the Lighting Instructions in this manual and in the Rating Plate on the appliance. **IMPROPER LIGHTING PROCEDURES COULD RESULT IN A FIRE HAZARD OR EXPLOSION HAZARD OR PROPERTY DAMAGE, INJURY OR LOSS OF LIFE.**

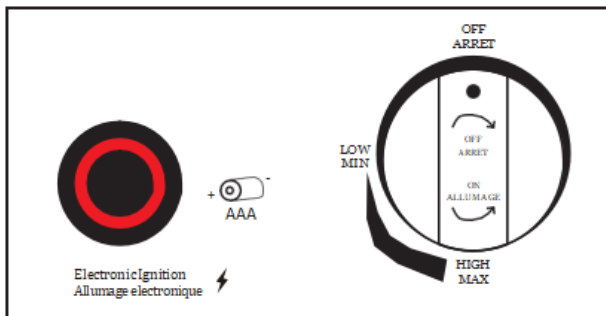

LIGHTING INSTRUCTIONS:

1. Read instructions before lighting;
2. Push and turn the knob to LOW;
3. Hold ignitor to light the burner, release control knob after 15 seconds; if burner does not light, wait 5 minutes, repeat; Adjust flame to desired flame with the control knob.

Observe Flame Height When Lit: The burner will display blue and yellow flames. These flames should be a blue / yellow color between 1~2 in. height (See below). These flames should not be yellow or produce thick smoke. This would indicate an obstruction of airflow through the burners. The flames should be blue with straight yellow tops.

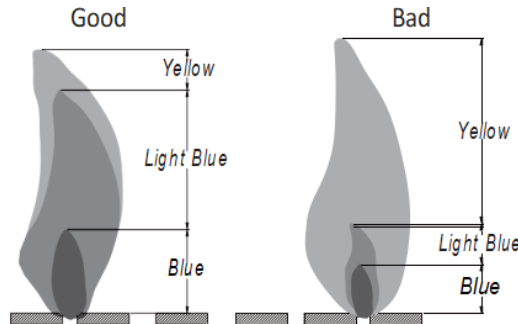

CARE AND MAINTENANCE

To enjoy the outstanding performance from your fire pit, make sure you perform the following activities on a regular basis:

1. Use warm soapy water for cleaning. Never use flammable or corrosive cleaning agents.
2. While cleaning the fire pit, make sure to keep the area around the burner dry at all times. DO NOT submerge the control valve assembly. If the gas control is submerged in water, DO NOT use it. It must be replaced.
3. Air flow must be unobstructed. Keep controls, burner, and circulating air passageways clean. Signs of possible blockage include:
 - (1). Gas odor with extreme yellow tipping of flame.
 - (2). Fire pit does NOT reach the desired temperature.
 - (3). Fire pit flame is excessively uneven.
 - (4). Fire pit makes popping noises.
 - (5). Spiders and insects can nest in burner or orifice. This dangerous condition can damage fire pit and render it unsafe for use. Clean burner holes by using a heavy-duty pipe cleaner. Compressed air may help clear away small particles.
4. Carbon deposits may create a fire hazard. Clean burner with warm soapy water if any carbon deposits develop.
5. Cover your fire pit with an outdoor weather cover when not in use to protect it from the elements.

NOTE: Always allow fire pit to cool COMPLETELY before you cover the fire pit with an outdoor weather cover or you attempt the service or maintenance.

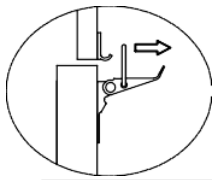

Lifting instruction:

1, Release the safety buckle

2, lift desktop slowly to the top of the chute following the below arrow.

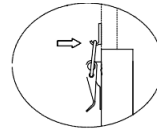
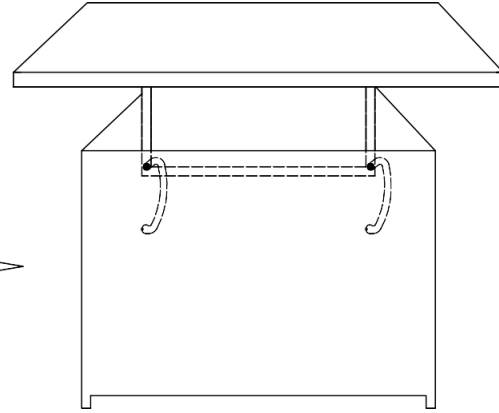
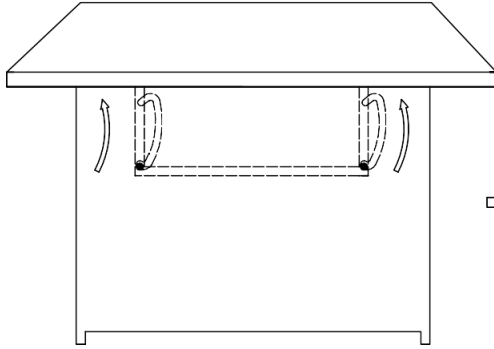

Descent instruction:

1, Pull down desktop slowly to the bottom of the chute following the below arrow ;

2, Fasten the safety buckle.

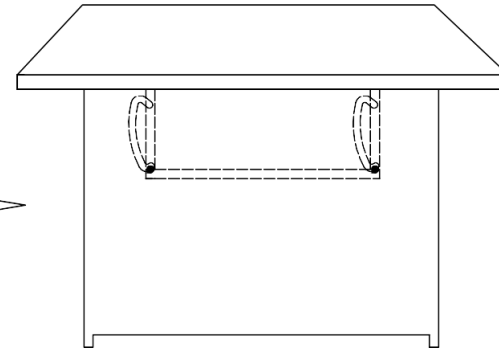
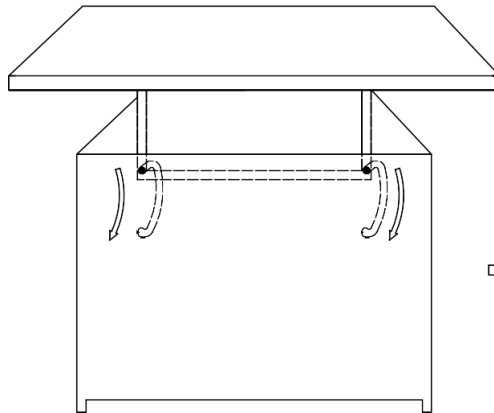

Q & A:

Q: Frame drilling holes not align?

A: If discrepancy less than 1/8 in., please loosen other relative bolts first, then adjust parts position and re-tight all bolts.

if discrepancy more than 1/4 in., it should be parts deformation during violent transportation, please contact us for parts replacement.

Q: Why cushion shrink packing and how to help it rebound faster?

A: We shrink packing cushion is to improve product value to cost, because it can save transport cost a lot. We filled it with more and high-quality filling than normal cushion to make sure it can be fully rebound. Following up this video(<https://youtu.be/IZAIHQU9Ial>)method to speed up rebounding.

Q: Coffee table legs un-even?

A: Loosen bolts, then press table downwards, then tighten bolts again. If it can not solve problem, please contact us for parts replacement.

Q: Wicker colors different on parts?

A: We make wicker stripes to fit for nature environment, colors may various circularly. So when those wicker stripes hand-woven on product randomly, it may looks different on parts.

Q: Why some swivel plate not work well?

A: Swivel plate may need a running-in period like 10~20 cycles. If it still not swivel well, please contact us for swivel plate replacement.

Q: Bolts are not long enough for assembly sometimes?

A: Sometimes gaps maybe larger than the bolts to reach out when assembly, please contact us for longer bolts. After all, those parts are woven by hand-made. But after it assembled and all bolts tightened, the gaps will be disappeared, because wicker parts are flexible surface.

Q: Parts received damaged?

A: Although we had already did our best to pack products well, there are also unpredictable transport damages accident happened from time to time. When it happens, please contact our after-sales email, state the order number/which shopping platform it comes from/one of the parcel tracking number, and provide the relevant pictures of the problem, we will immediately provide you with a suitable replacement parcel.

Q:Received item but missing hardware or parts

A:Please contact our after-sales email, state the order number/which shopping platform it comes from/one of the parcel tracking number, and provide the relevant pictures of the problem, we will immediately provide you with a suitable replacement parcel.