

ASSEMBLY INSTRUCTION

PLEASE READ BEFORE ASSEMBLING!

Tip #1: Make sure you've taken all the pieces and hardware out of its packaging before discarding the box.

Tip #2: Using page 2 and/or page 3 of instruction manual make sure all pieces and hardware are accounted for.

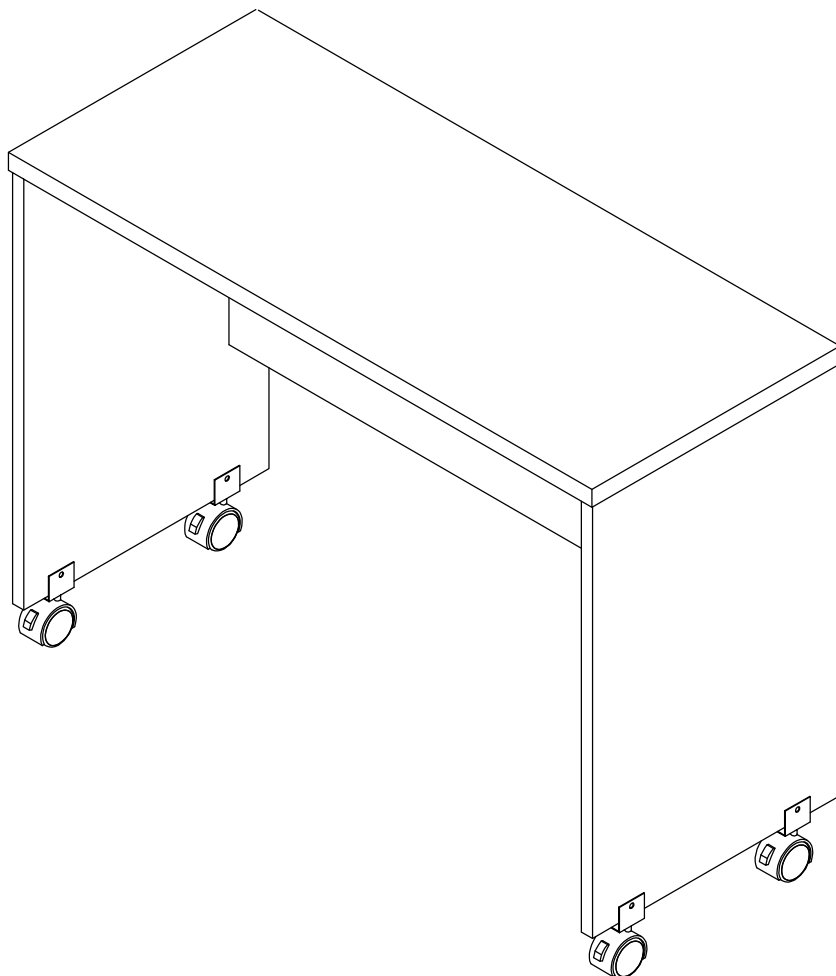



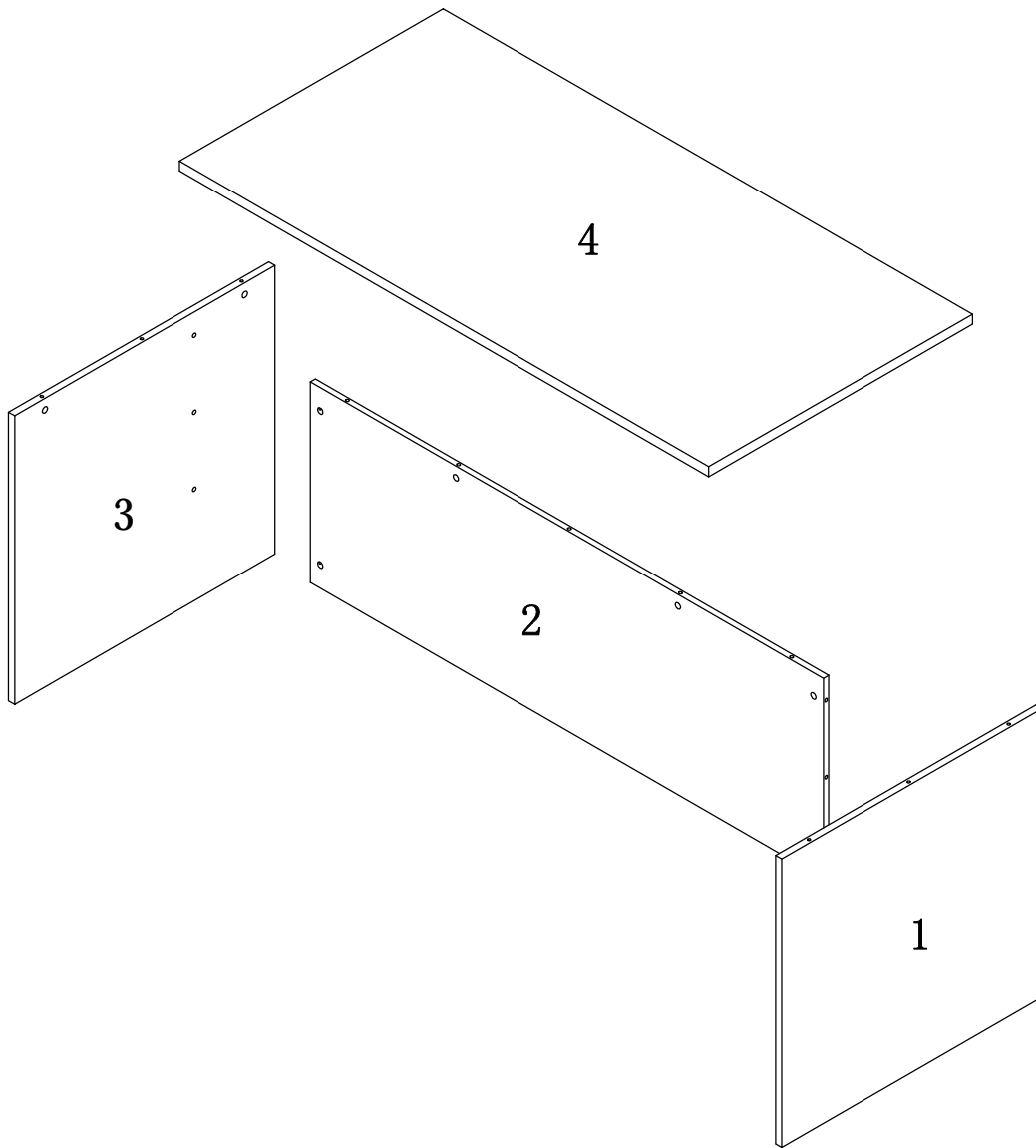

PARTS IDENTIFICATION



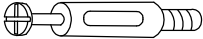

(1)	1pc	(3)	1pc
(2)	1pc	(4)	1pc

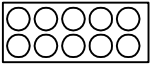
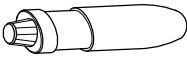
HARDWARE IDENTIFICATION

A		L29	10pcs
B		φ 15	10pcs
C		H50	2pcs
D		H50	2pcs
E		M6、φ 6×25	4pcs
F		φ 18	10pcs
G		φ 8×25	7pcs
H		Glue: For securing please apply to wood dowel first before inserting into panel	1pc

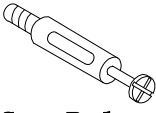
ASSEMBLY INSTRUCTION

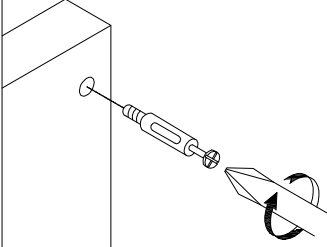
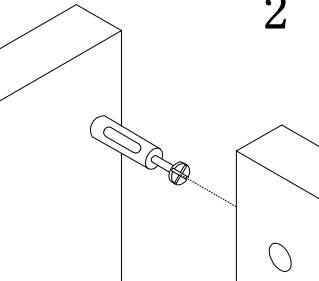
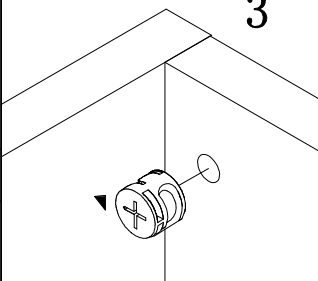
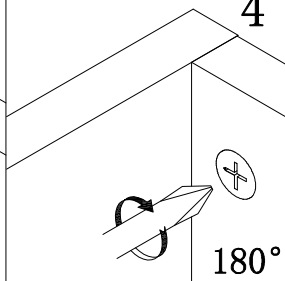
HOW TO  Cam Bolt  Cam Lock	1	2	3	4
				
	1. Screw Cam Bolt into panel.	2. Insert Cam Bolt into bolt hole of joining panel.	3. Insert Cam Lock. arrow facing bolt.	4. Gently turn Cam Lock clockwise to lock position.

ASSEMBLY INSTRUCTION

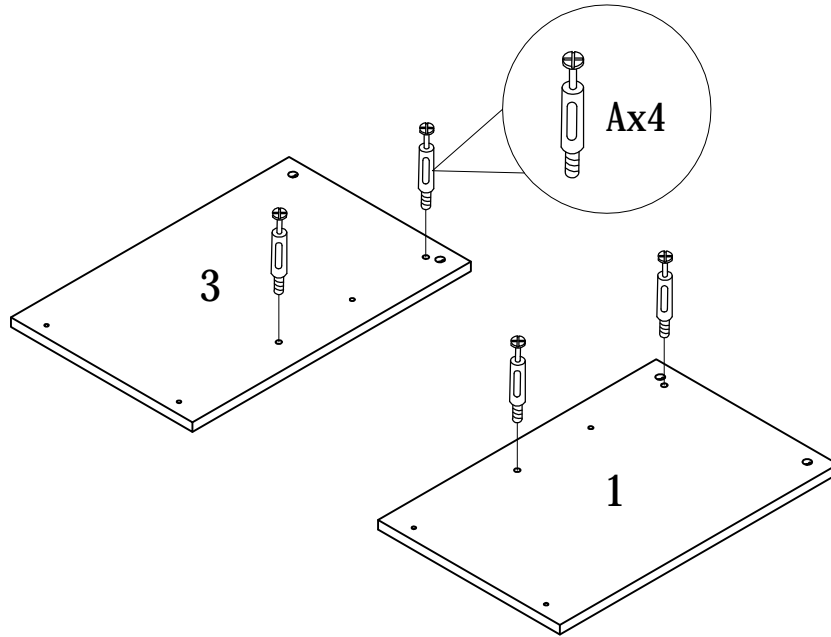

STEP1

STEP2

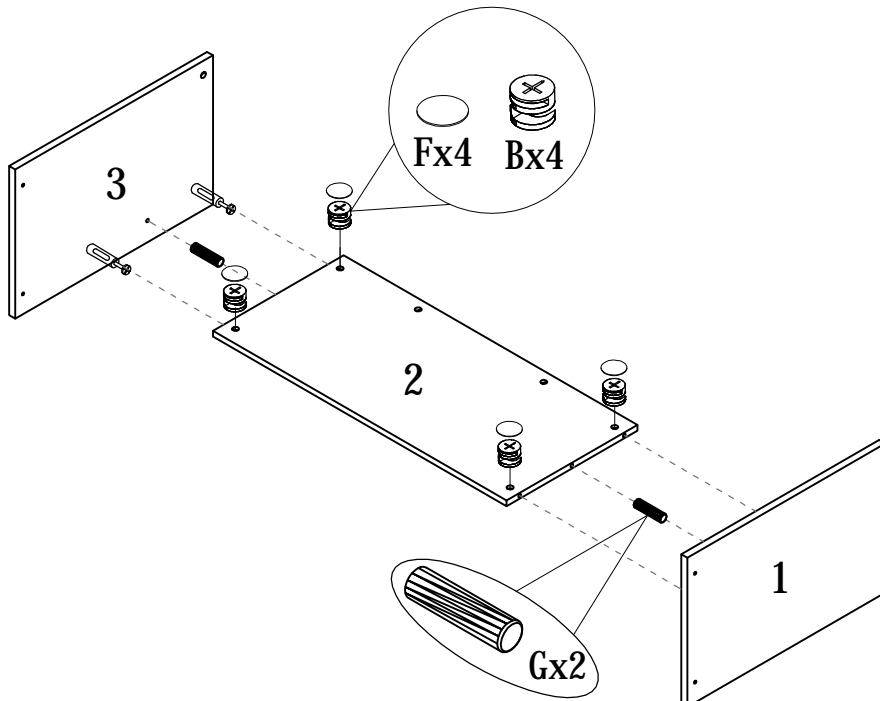

ASSEMBLY INSTRUCTION

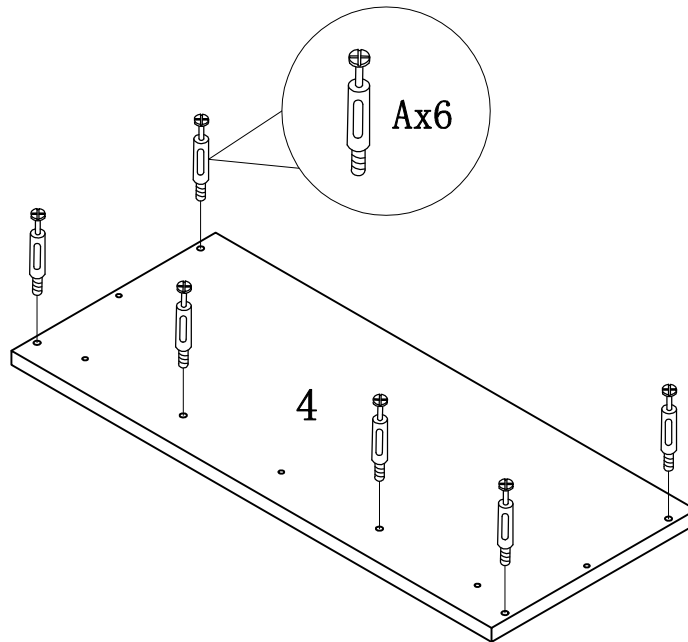

STEP3

STEP4

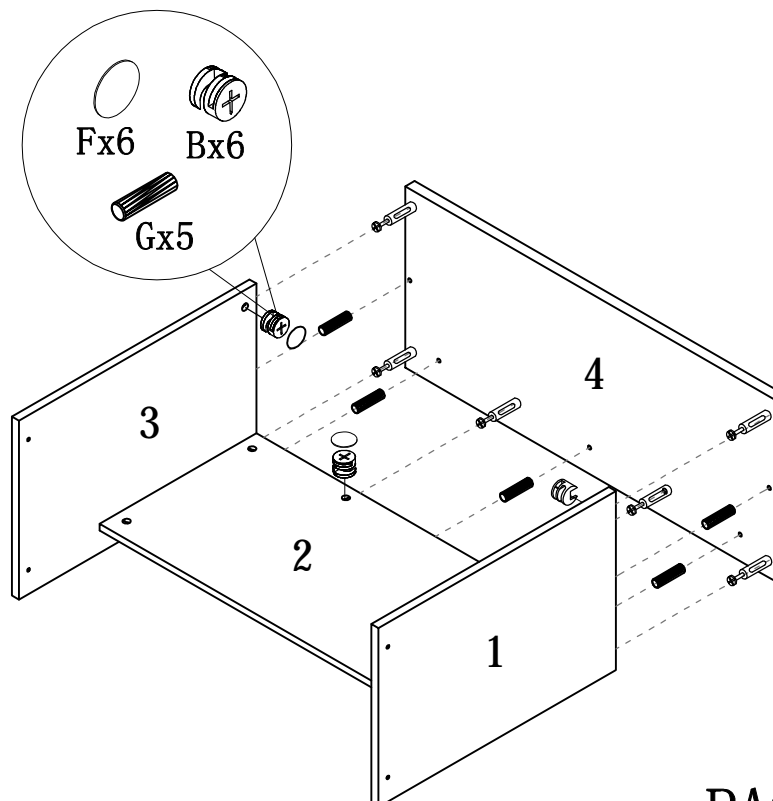

ASSEMBLY INSTRUCTION

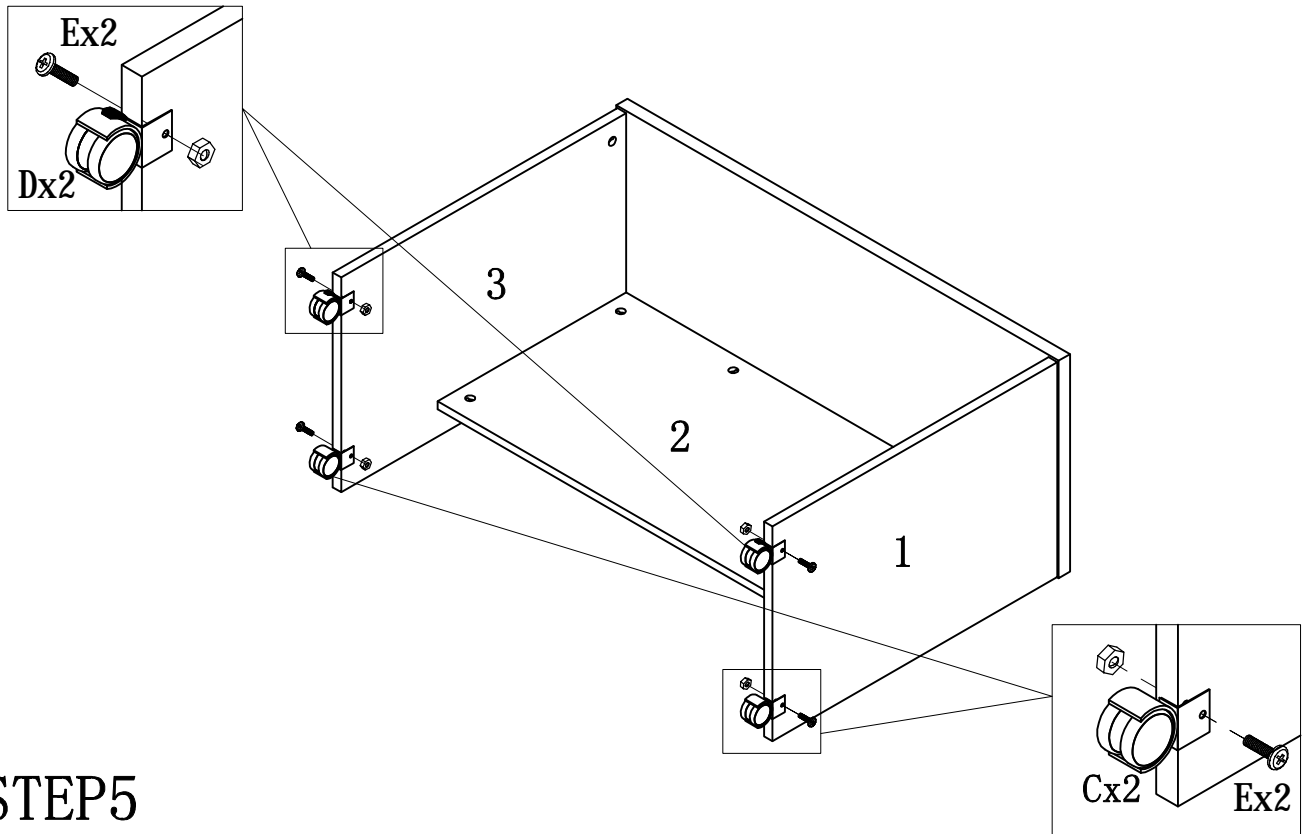

STEP5

STEP6

