

ASSEMBLY INSTRUCTION



This instruction booklet contains important safety information. please read and keep for future reference.

This is a single seat sofa.

- 1.This sofa ships in a box.
- 2.Our cushions are vacuum packed for convenient shipping. Please allow 10 days after cutting for them to fully expand to their original shape and for any wrinkles to disappear.
- 3.In the event that a part is damaged or missing,no need to return the product,wewill gladly help and ship your replacement parts free of charge.

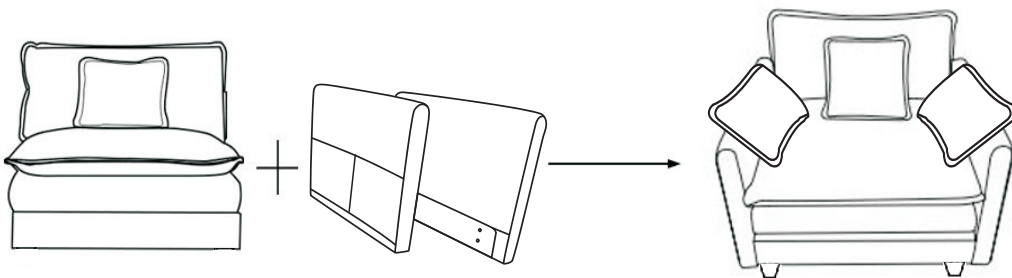

IF YOU BUY A SINGLE SOFA
please follow below assembly instruction

Parts included

Parts List (BOX 1)

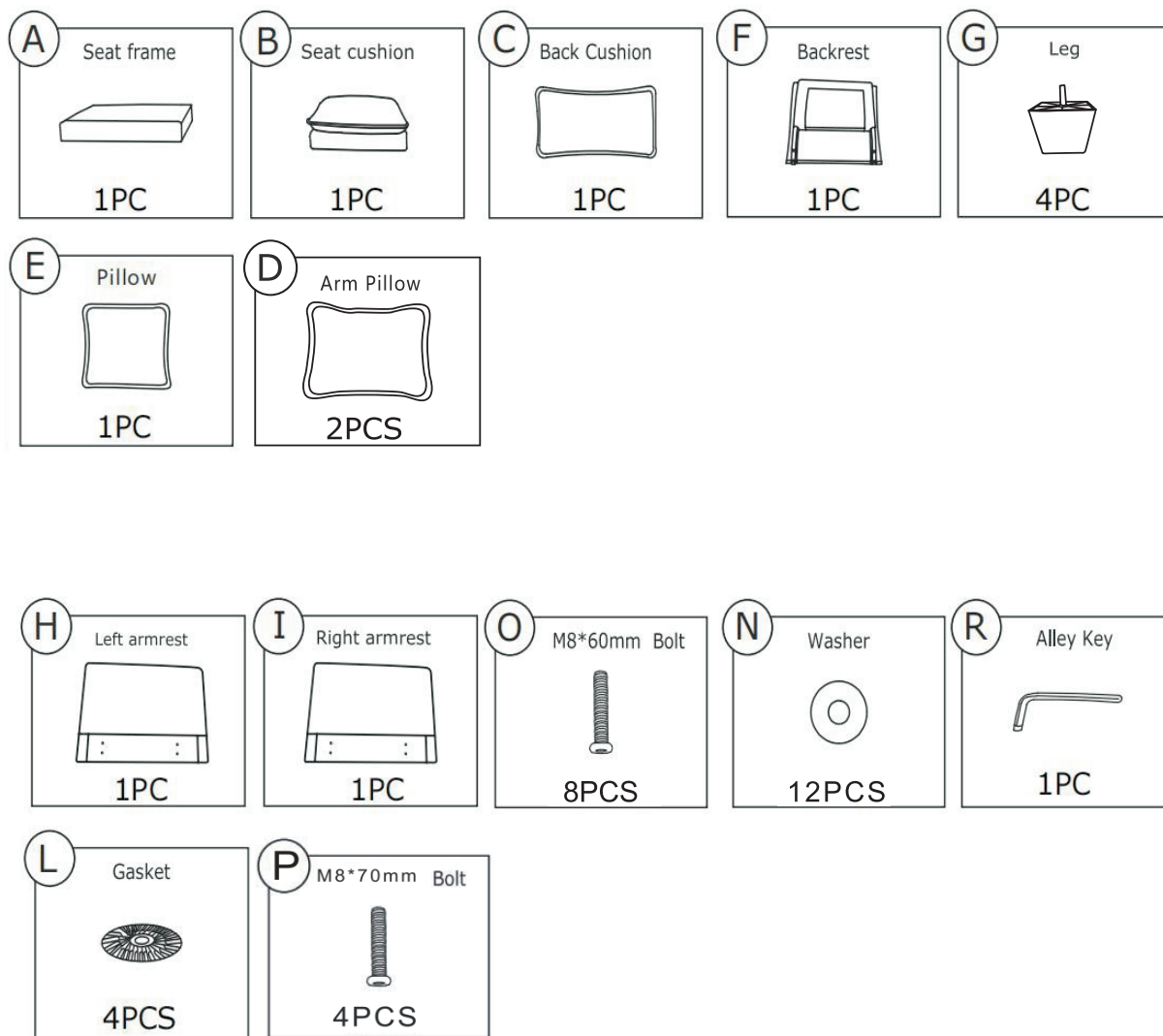

Note: Please retain all boxes until you are certain that your product isn't damaged and that you do not wish to return it. Disposal of boxes may prevent our ability to resolve your request.

ASSEMBLY STEPS

STEP 1: Assemble the Left armrest (H) and the Right armrest (I) to the Seat frame (A) with Washers (N) and Bolts (O).

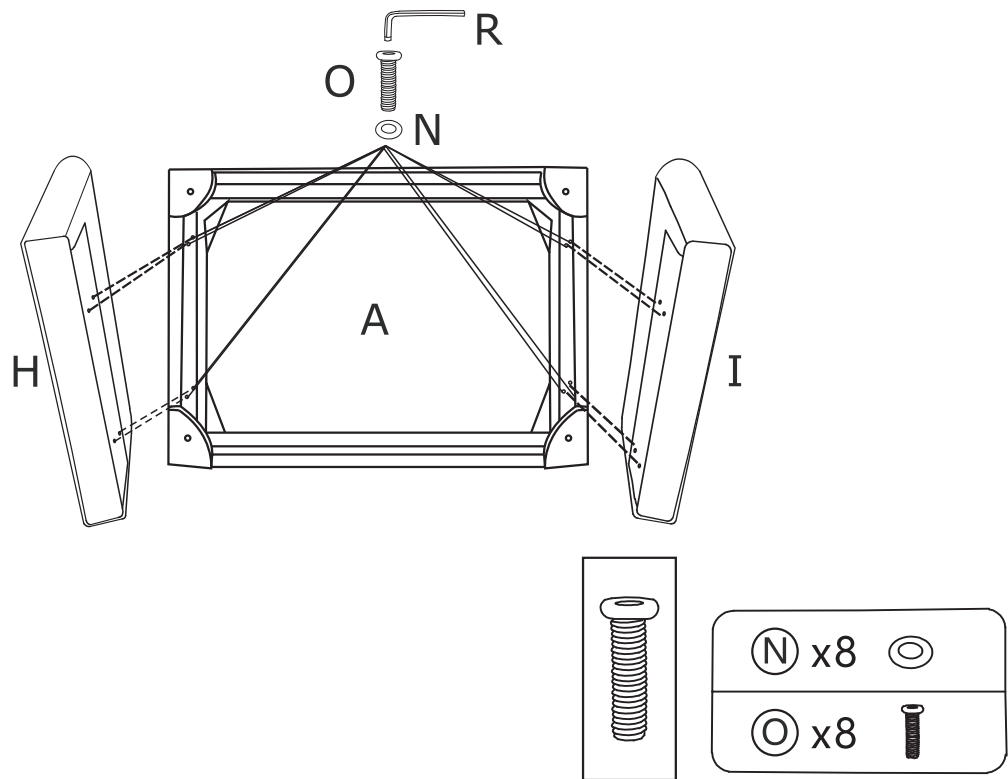

STEP 2: Assemble the Legs (G) on the sofa with Gaskets (L).

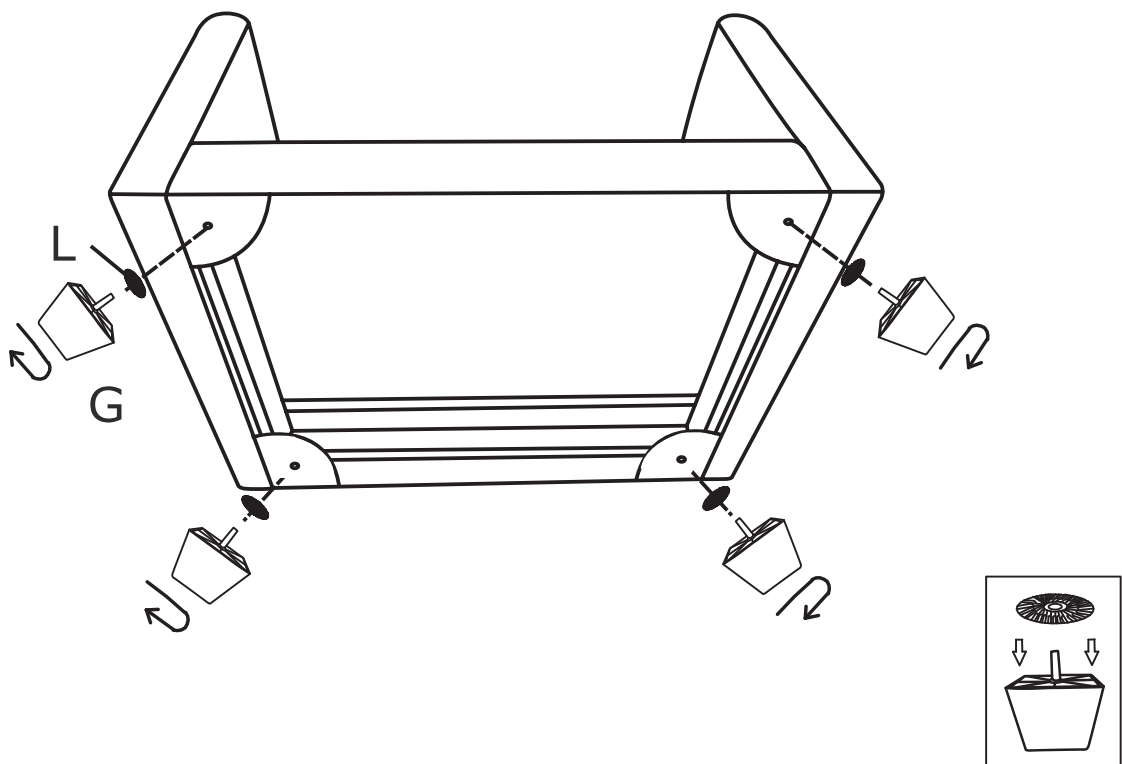

STEP 3: Align the holes on the backrest F with those on the seat frame A. Use the washer N and screw P to tighten them to 70% of the full tightness, and then tighten all the screws on the seat.

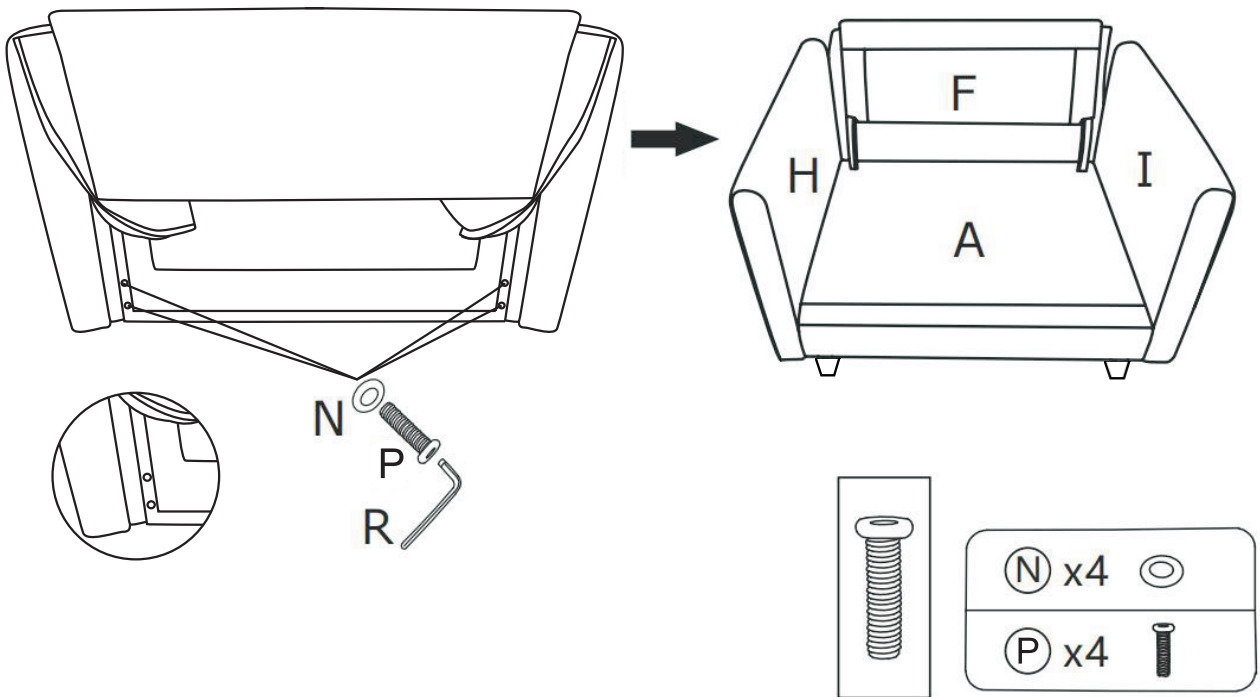

STEP 4: The cushion is packaged by vacuum compression. Slowly rebound within 10 days after cutting, and if the fabric has wrinkles, they will gradually disappear

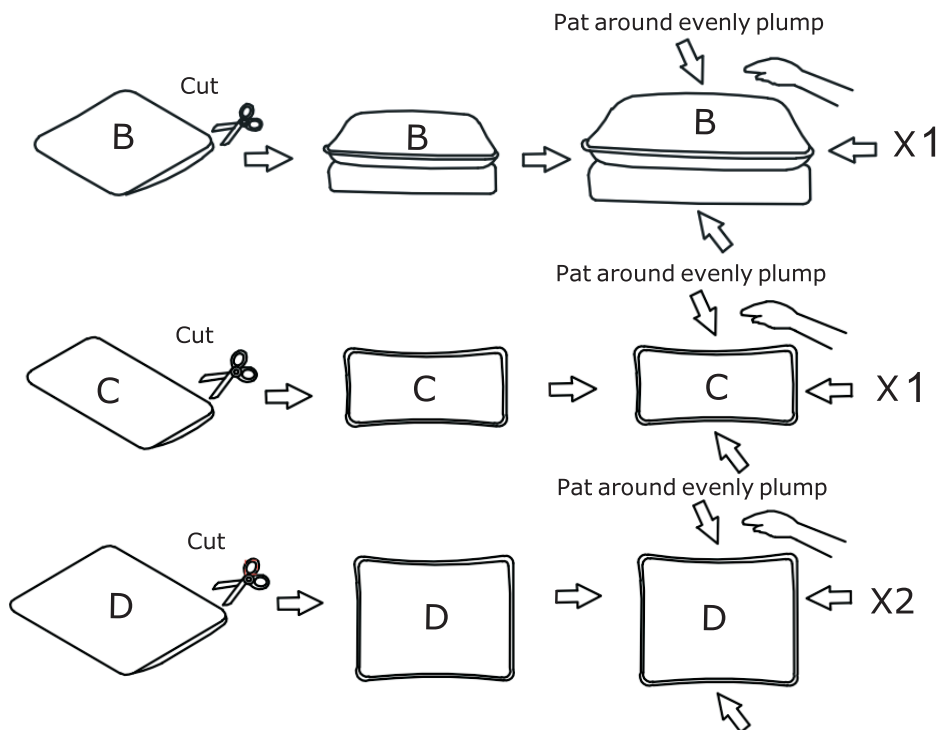

STEP 5: Place Seat cushion (B) and back cushion (C),and pillow (E) on sofa and make sure it's will fitted.

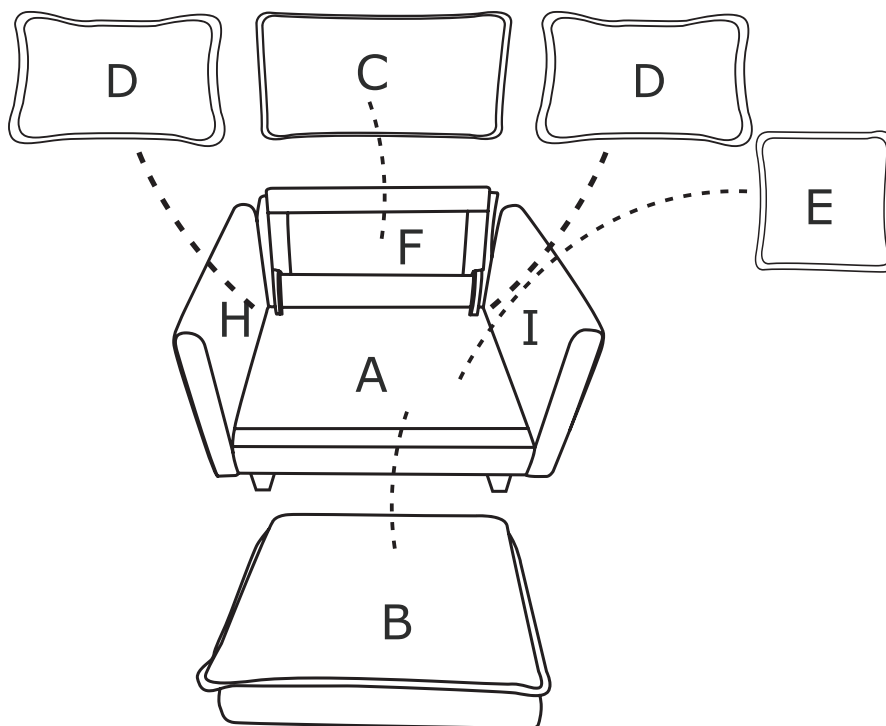

STEP 6: If the fabric has wrinkles, it will basically diappear after standing for 10 days. Well done!! You can enjoy your leisure time on the sofa now.

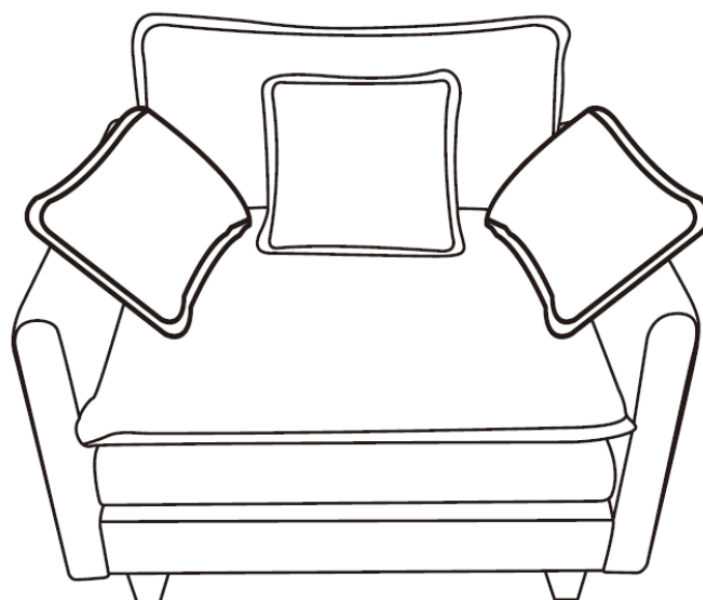

ASSEMBLY INSTRUCTION

Ottoman

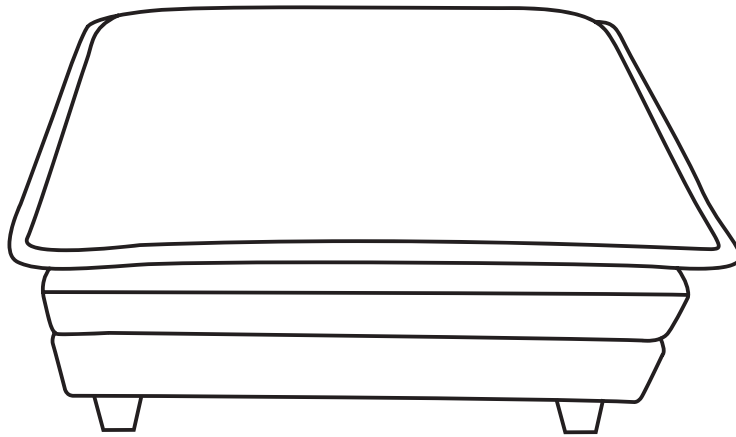





Thank you for choosing our product.

To ensure safe and satisfactory use of this product, please carefully read the below instructions beforehand.

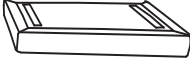
1. The cushion is packaged by vacuum compression. Slowly rebound within 10 days after cutting, and if the fabric has wrinkles, they will gradually disappear.
2. In the event that a part is damaged or missing, no need to return the product, we will gladly help and ship your replacement parts free of charge.

PART LIST & HARDWARE

M Ottoman frame  1PC	S Ottoman cushion  1PC	G Leg  4PCS	L Gasket  4PCS
---	---	--	---

Note: Please retain all boxes until you are certain that your product isn't damaged and that you do not wish to return it. Disposal of boxes may prevent our ability to resolve your request.

ASSEMBLY STEPS

STEP 1: Assemble the Legs (G) on the ottoman frame with Gaskets (L) .

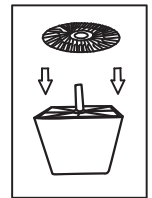
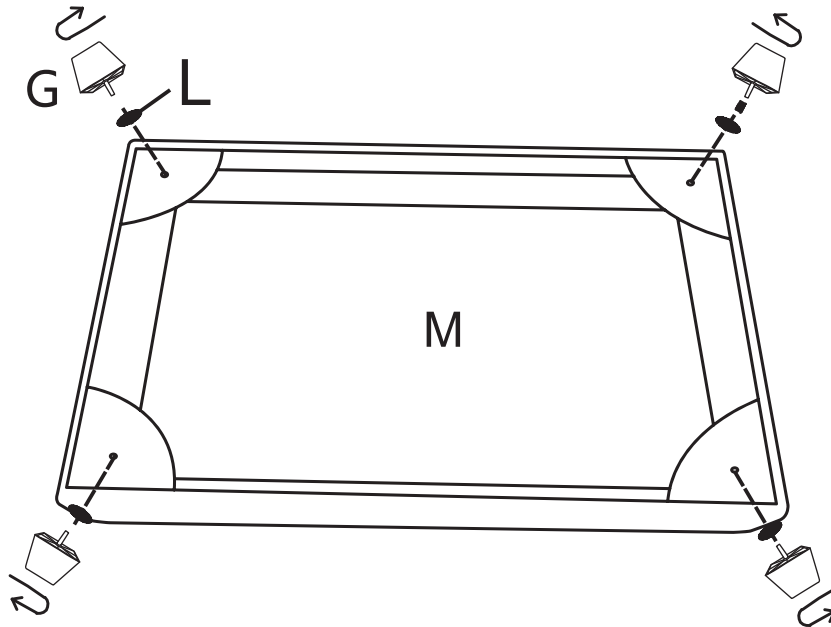

STEP 2: The cushion is packaged by vacuumcompression. Slowly rebound with in 10 days aftercutting, and if the fabric has wrinkles, they will gradually disappear

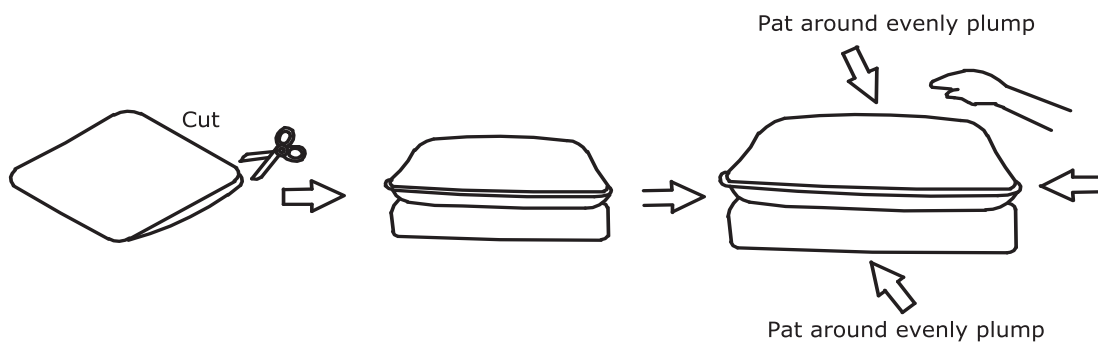

STEP 3: Place seat ottoman cushion (S) on the ottoman frame (M).

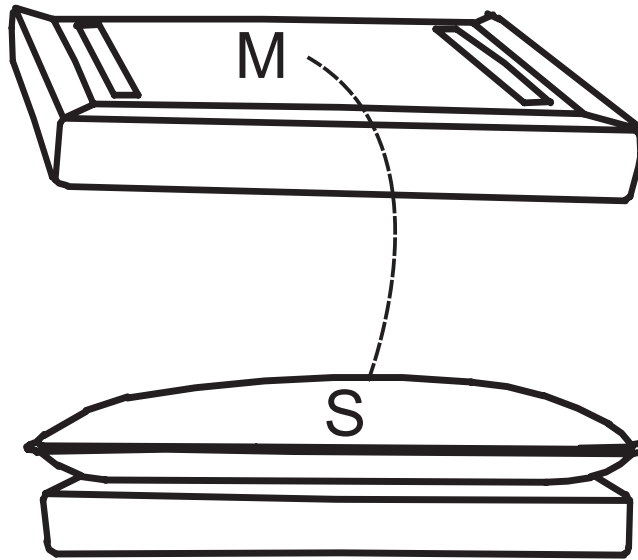

STEP 4: If the fabric has wrinkles, it will basically disappear after standing for 10 days. Well done!! You can enjoy your leisure time on the sofa now.

