

ASSEMBLY INSTRUCTIONS
INSTRUCTIONS DE MONTAGE
INSTRUCCIONES DE ENSAMBLAJE

Refreshment Cart
Charrette pour les Rafraîchissements
Carreta para los Refrescos

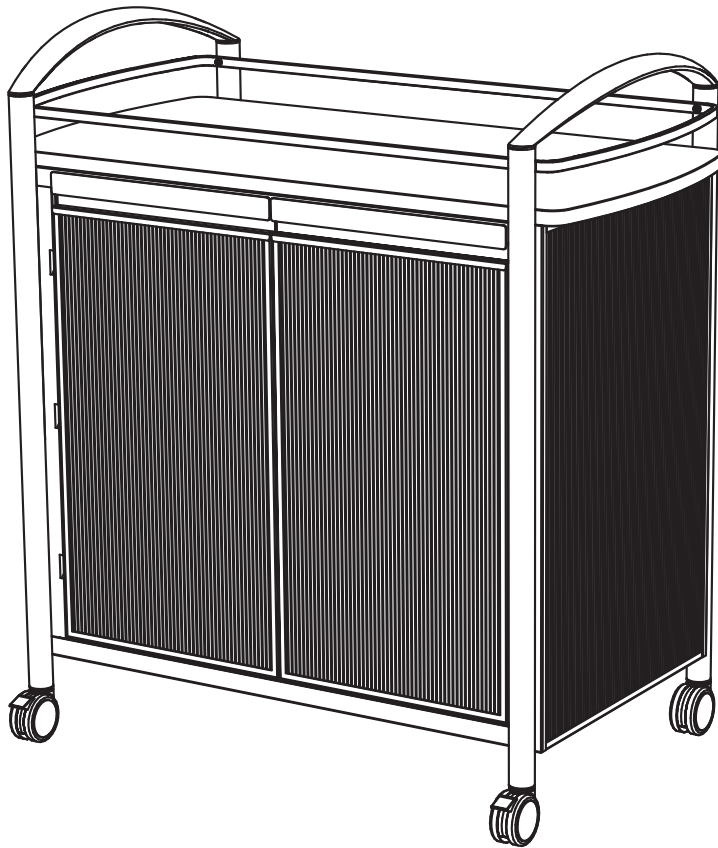

TOOLS REQUIRED: Phillips Screwdriver
OUTILS REQUIS : *Tournevis à pointe cruciforme*
HERRAMIENTAS REQUERIDAS: Destornillador Phillips

Two People Recommended.

On recommande que l'assemblage soit effectué par deux personnes.

Se recomienda dos personas para el ensamblaje.

Parts List / Liste des Pièces / Lista de Piezas			
Code/ Código	DESCRIPTION / DESCRIPTION / DESCRIPCIÓN	Qty./ Qté/ Cant.	Part No./ N° de Pièce / No. de Pieza
(A)	Leg / Pied / Pata	4	
(B)	Side Panel / Panneau latéral / Panel lateral	2	
(C)	Back Frame / Cadre de l'arrière / Marco trasero	1	
(D)	Back Panel / Panneau arrière / Tablero trasero	1	
(E)	Front Frame / Frontal cadre / Frontal marco	1	
(F)	Left Door / Porte gauche / Puerta izquierda	1	
(G)	Right Door / Porte droit / Puerta derecha	1	
(H)	Bottom Shelf / Étagère inférieur / Estante del fondo	1	
(I)	Center Shelf / Étagère central / Estante central	1	
(J)	Top Panel/ Panneau supérieur / Tablero superior	1	
(K)	Handle / Poignée / Asa	2	
(L)	Ring / Anneau / Anillo	1	

§ **Note:** When corresponding about parts, be sure to state color: **Black (BL)**, or **Gray (GR)** .





§ *Noter:* Quand correspondre au sujet de parties, soyez sûr d'affirmer la couleur: **Noir (BL)** ou **Gris (GR)** .



§ **Note:** Al corresponder sobre las piezas, esté seguro declarar el color: Negro(BL)o Gris (GR).

§§ **Note:** When corresponding about parts, be sure to state color: **Gray (GR)**, or **Cherry (CY)** .

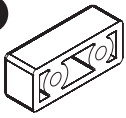
§§ *Noter:* Quand correspondre au sujet de parties, soyez sûr d'affirmer la couleur: **Gris (GR)** ou **Cerise (CY)** .

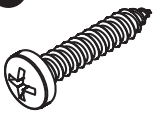
§§ **Note:** Al corresponder sobre las piezas, esté seguro declarar el color:Gris (GR) o Cereza (CY).

Hardware Pack / Paquet Matériel / Paquete Material:		
<p>(M)</p>  <p>Long Screw <i>Longue vis</i> Tornillo largo Qty. / Qté. / Cant. 12</p>	<p>(N)</p>  <p>Small Screw <i>Vis petit</i> Tornillo pequeño Qty. / Qté. / Cant. 6</p>	<p>(O)</p>  <p>Doorstop <i>Butoir</i> Tope Qty. / Qté. / Cant. 1</p>
<p>(P)</p>  <p>Short Screw <i>Vis courte</i> Corto tornillo Qty. / Qté. / Cant. 2</p>	<p>(Q)</p>  <p>Medium Screw <i>Vis moyenne</i> Tornillo medio Qty. / Qté. / Cant. 4</p>	<p>§§§Note: When corresponding about casters, be sure to state color: 2-Tone (NC) or Black (BL). §§§<i>Noter:</i> Quand correspondre au sujet de roues, soyez sûr d'affirmer la couleur: Deux tons (NC) ou Noir (BL). §§§ Note: Al corresponder sobre las ruedas, esté seguro declarar el color: Dos tonos (NC) o Negro (BL).</p>

Hardware Pack / Paquet Matériel / Paquete Material:	
<p>(R)</p>  <p>Caster With Brake <i>Roue avec Frein</i> Rueda con Freno Qty. / Qté. / Cant. 2</p>	<p>(S)</p>  <p>Caster Without Brake <i>Roue sans Frein</i> Rueda sin Freno Qty. / Qté. / Cant. 2</p>

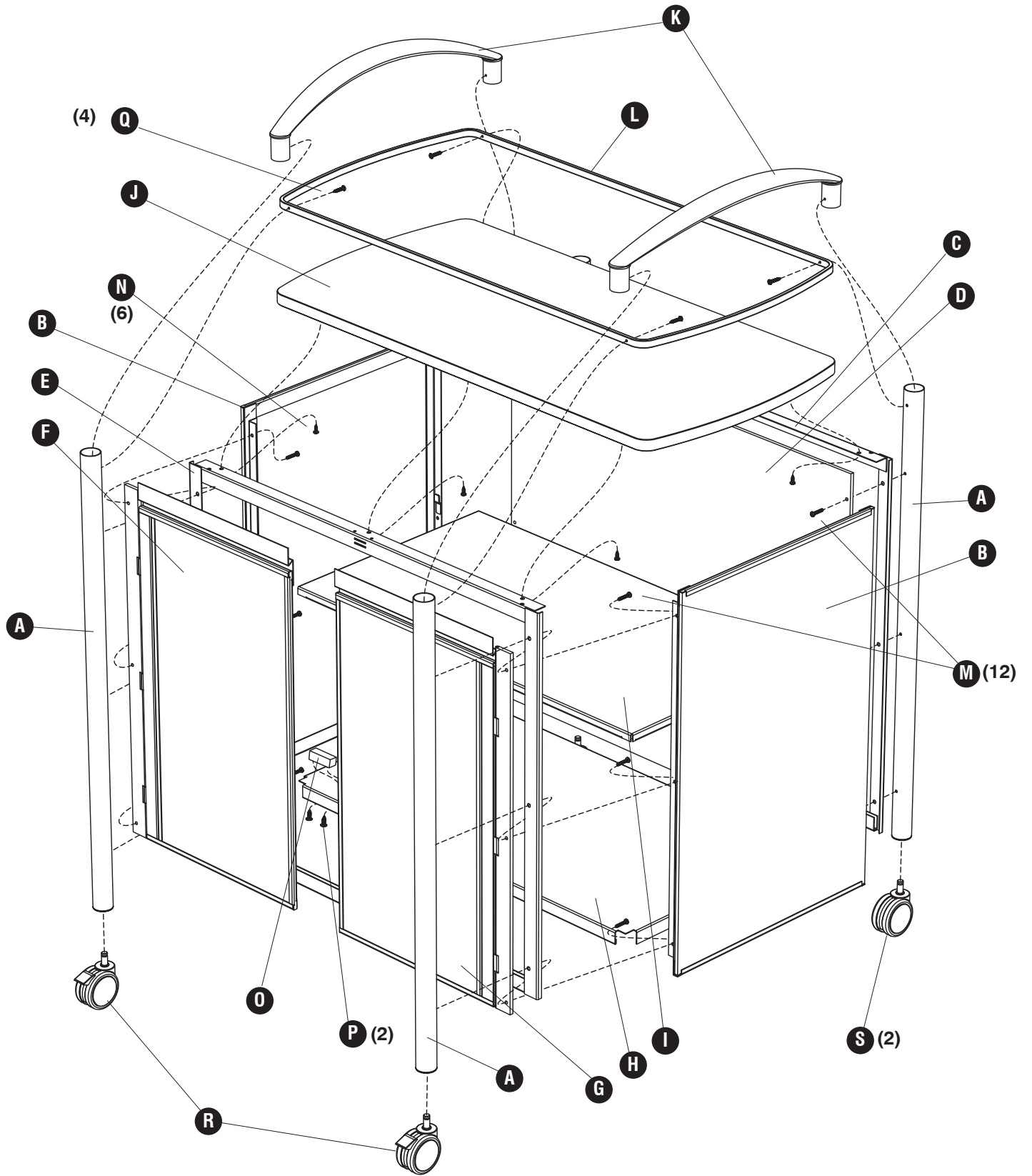

1

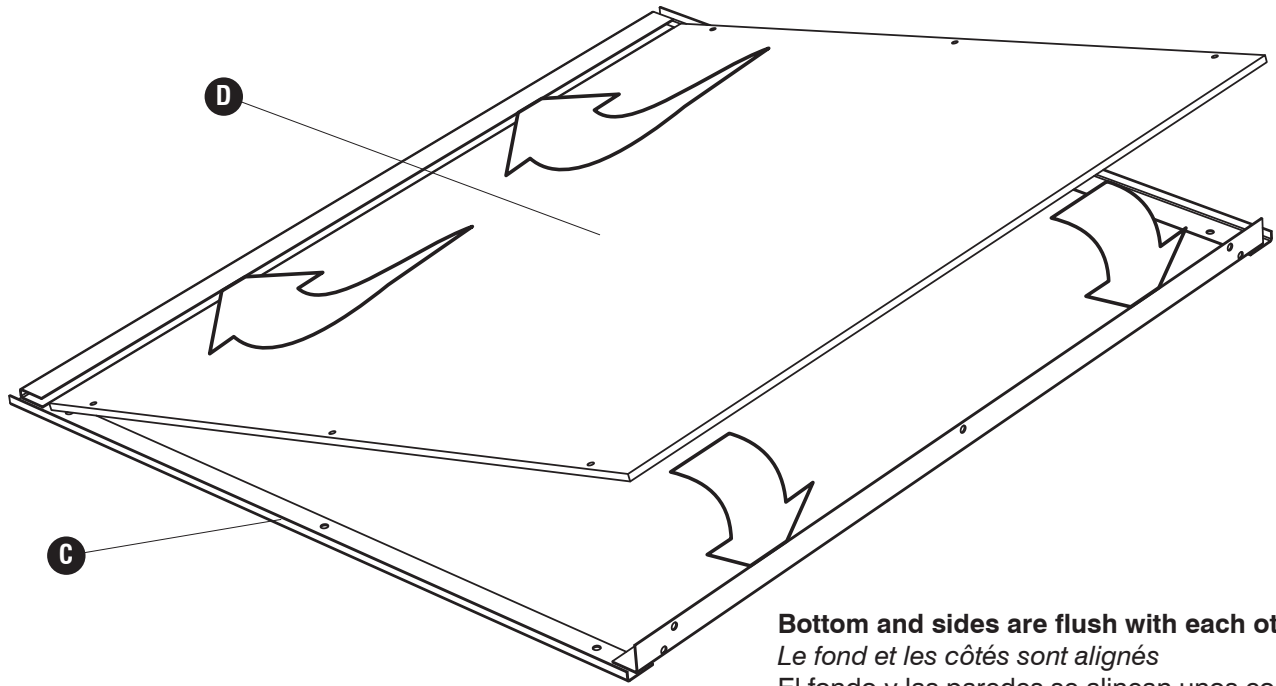

Bottom and sides are flush with each other
Le fond et les côtés sont alignés
El fondo y las paredes se alinean unos con otros

2 **M**  (3)

IMPORTANT: Orient the parts as shown!
Important: Vous devez orienter les pièces comme le montre!
¡IMPORTANTE! Usted debe orientar las piezas tal y como se muestra!

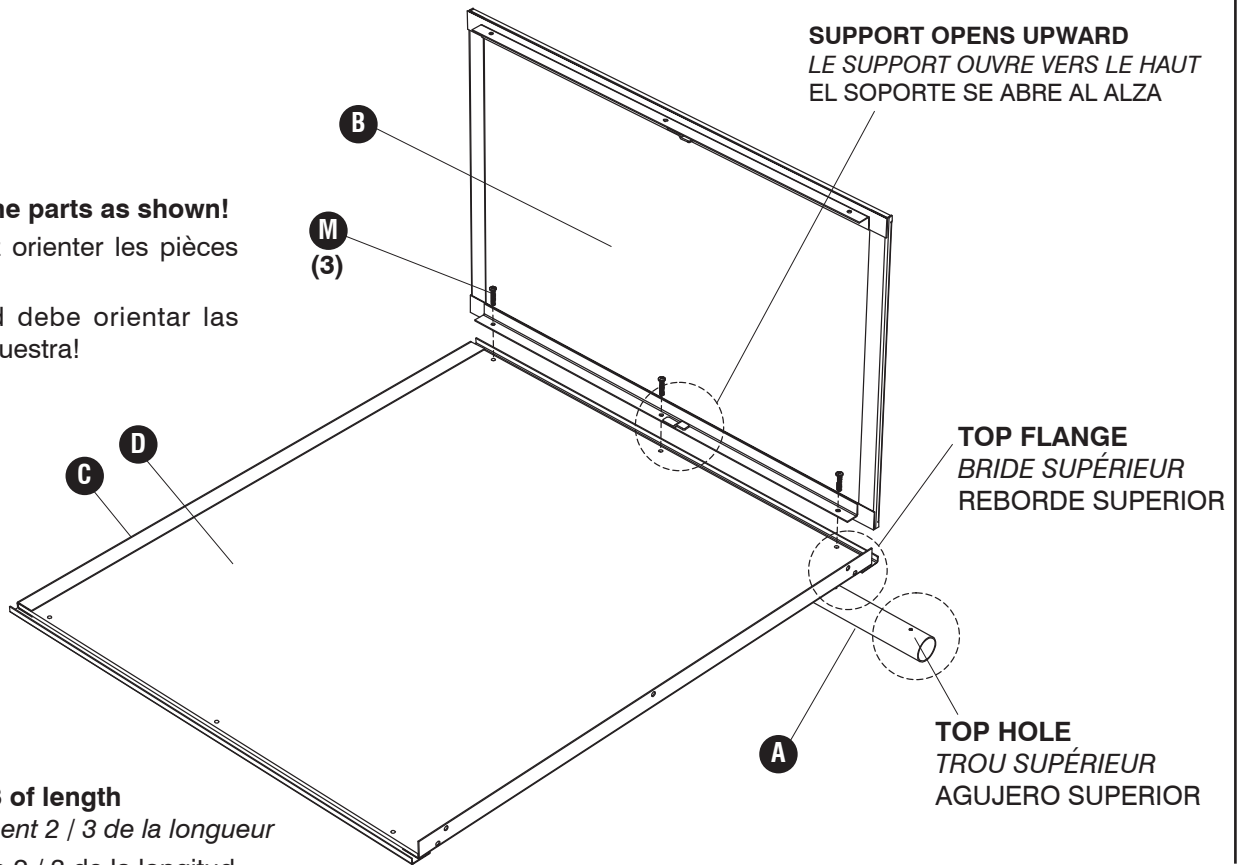

SUPPORT OPENS UPWARD
LE SUPPORT OUVRE VERS LE HAUT
EL SOPORTE SE ABRE AL ALZA

TOP FLANGE
BRIDE SUPÉRIEUR
REBORDE SUPERIOR

TOP HOLE
TROU SUPÉRIEUR
AGUJERO SUPERIOR

Insert screws only 2/3 of length
Insérer les vis à seulement 2 / 3 de la longueur
Inserte los tornillos sólo 2 / 3 de la longitud

3 **M**  (3)

SUPPORT OPENS UPWARD
LE SUPPORT OUVRE VERS LE HAUT
EL SOPORTE SE ABRE AL ALZA

TOP FLANGE
BRIDE SUPÉRIEUR
REBORDE SUPERIOR

TOP HOLE
TROU SUPÉRIEUR
AGUJERO SUPERIOR

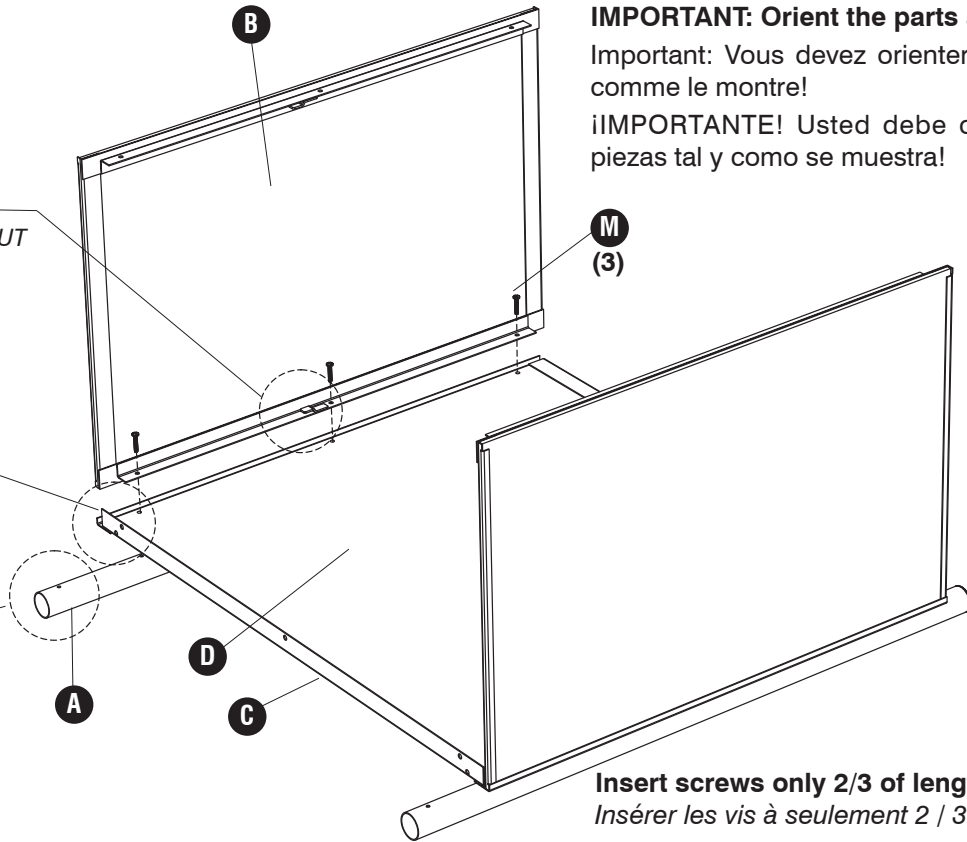

IMPORTANT: Orient the parts as shown!
Important: Vous devez orienter les pièces comme le montre!
¡¡IMPORTANTE! Usted debe orientar las piezas tal y como se muestra!

Insert screws only 2/3 of length
Insérer les vis à seulement 2 / 3 de la longueur
Inserte los tornillos sólo 2 / 3 de la longitud

4 **O**  **P**  (2)

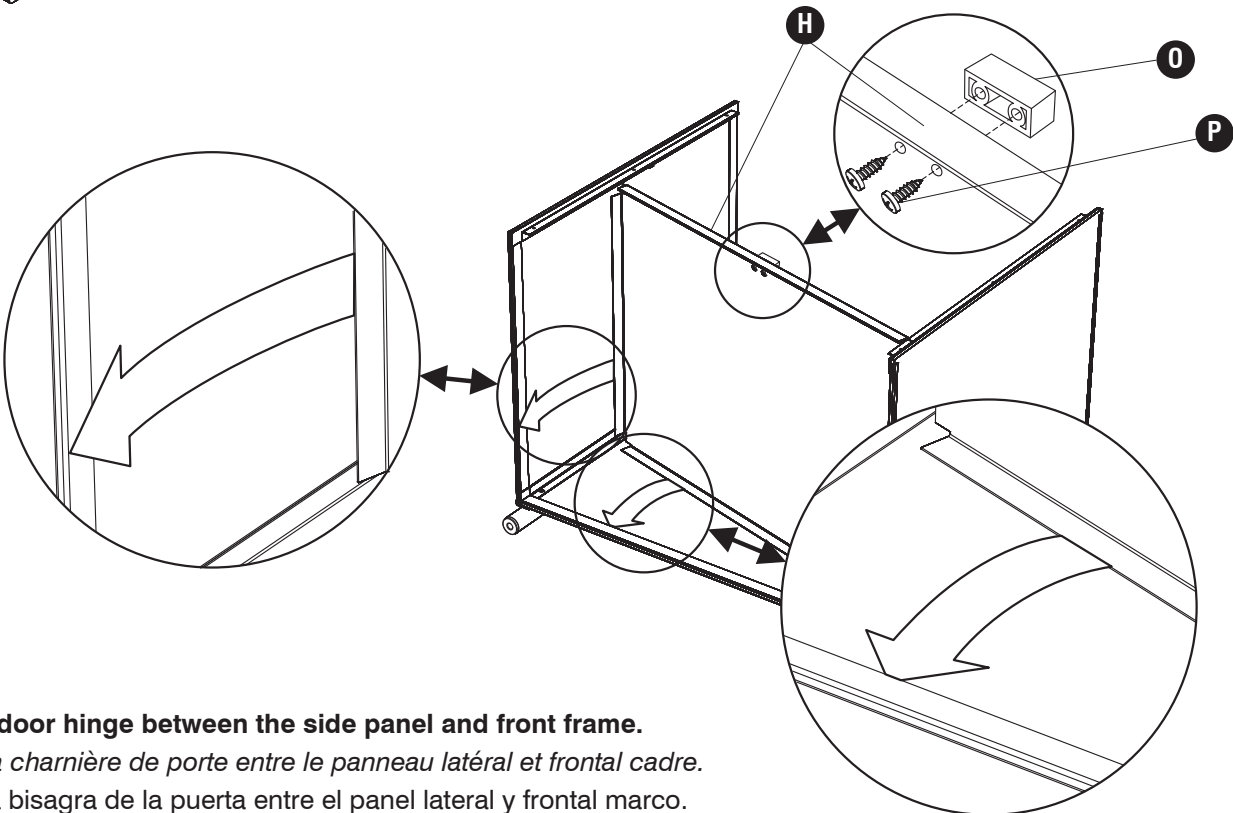

Place the door hinge between the side panel and front frame.
Place de la charnière de porte entre le panneau latéral et frontal cadre.
Coloque la bisagra de la puerta entre el panel lateral y frontal marco.

5

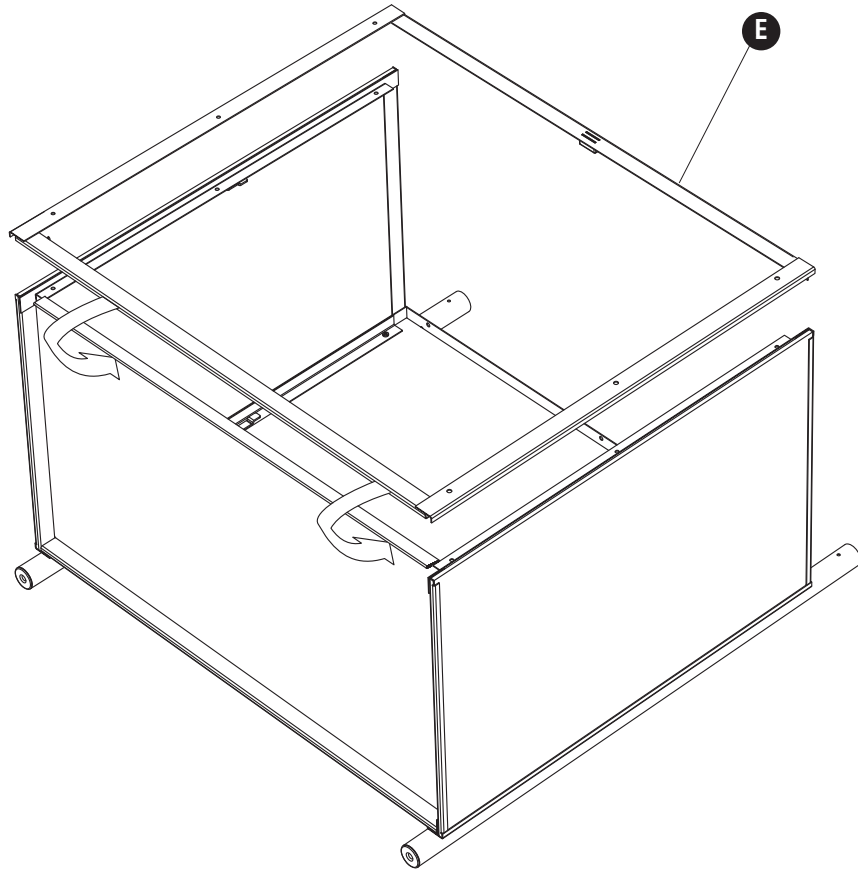

6



Insert screws only 2/3 of length

Insérer les vis à seulement 2 / 3 de la longueur

Inserte los tornillos sólo 2 / 3 de la longitud

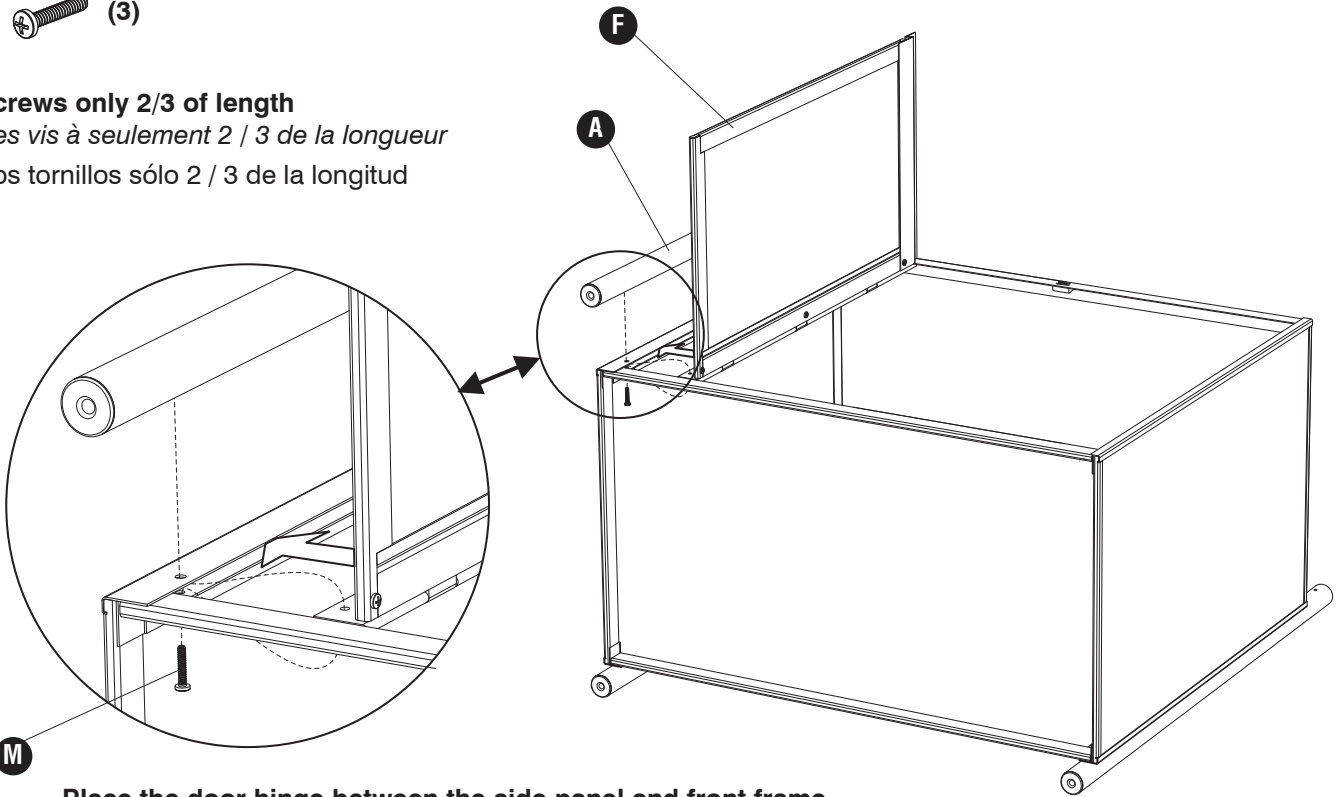

Place the door hinge between the side panel and front frame.

Place de la charnière de porte entre le panneau latéral et frontal cadre.

Coloque la bisagra de la puerta entre el panel lateral y frontal marco.

7**M**  (3)

Place the door hinge between the side panel and front frame.
Place de la charnière de porte entre le panneau latéral et frontal cadre.
Coloque la bisagra de la puerta entre el panel lateral y frontal marco.

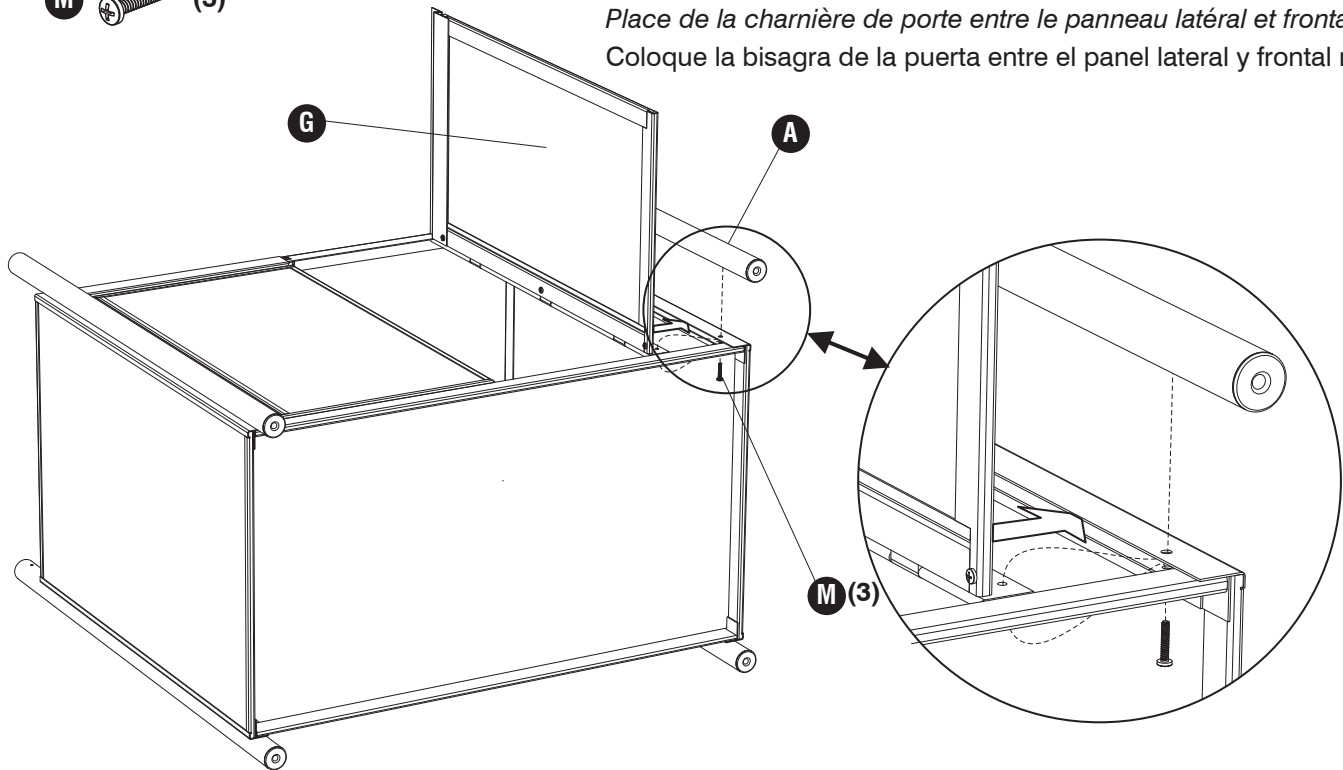

Close doors and adjust for proper alignment, then tighten all door screws

Fermez les portes et ajuster jusqu'à ce que l'alignement est correct, puis serrez toutes les vis de la porte

Cierre las puertas y ajustar la alineación adecuada, a continuación, apriete todos los tornillos de las puertas

8**N**  (6)

**Tighten the top screws,
 then the back leg screws**
*Serrez les vis du haut, puis
 les vis de la jambe arrière*
*Apriete los tornillos del
 tablero superior, entonces
 los tornillos de las patas de
 atrás*

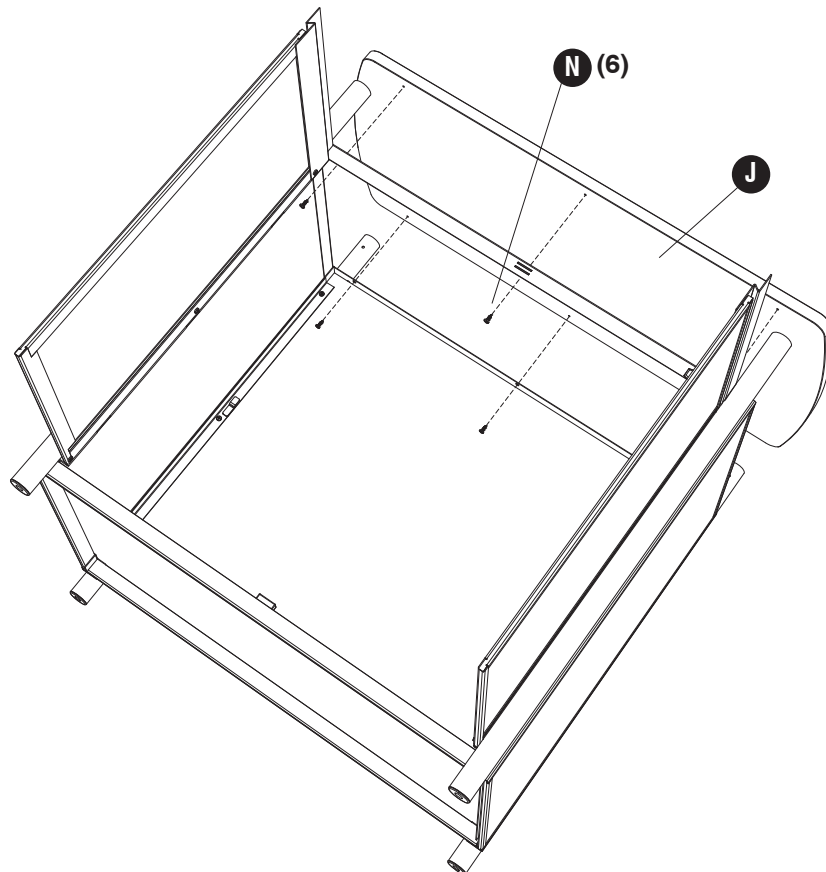

9

R (2) S (2)

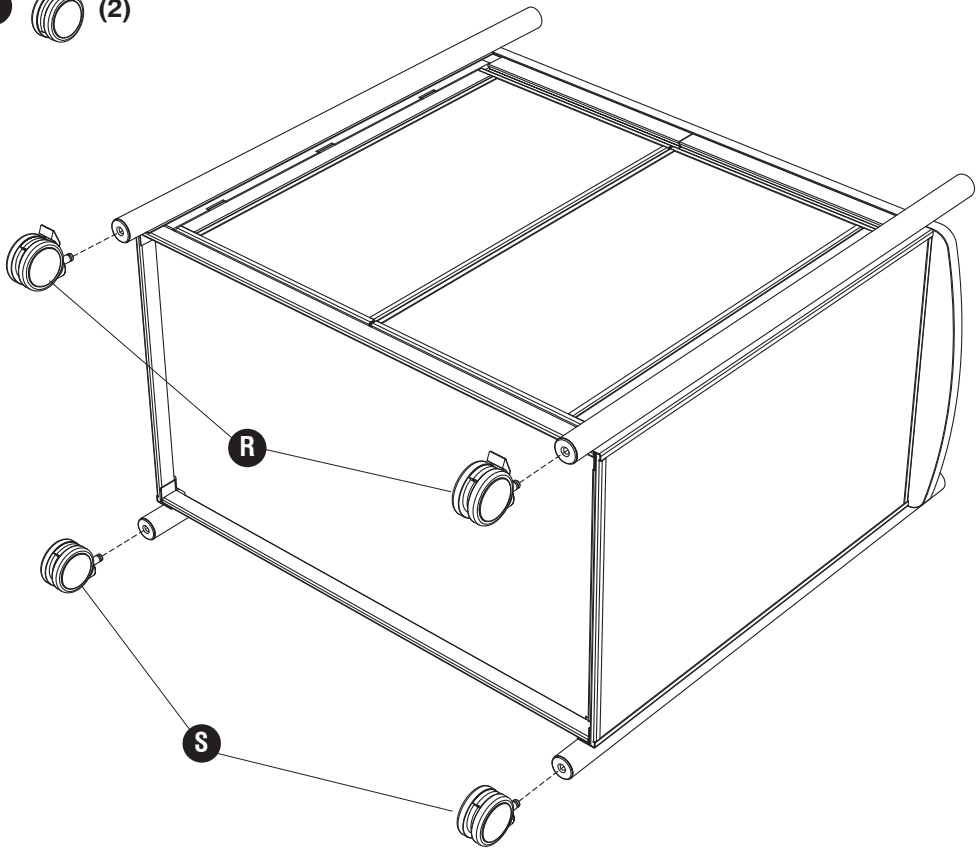

10

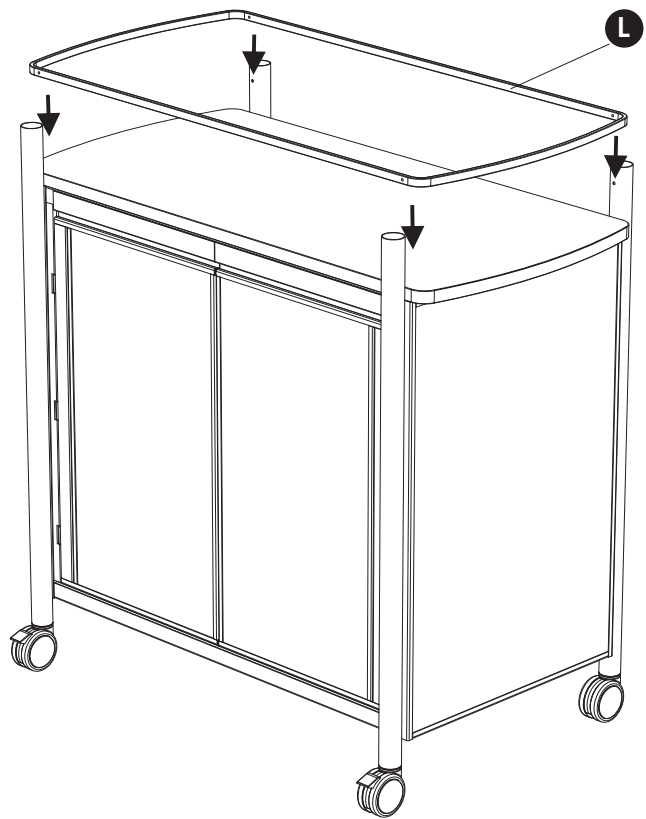

11

Q

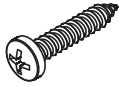

(4)

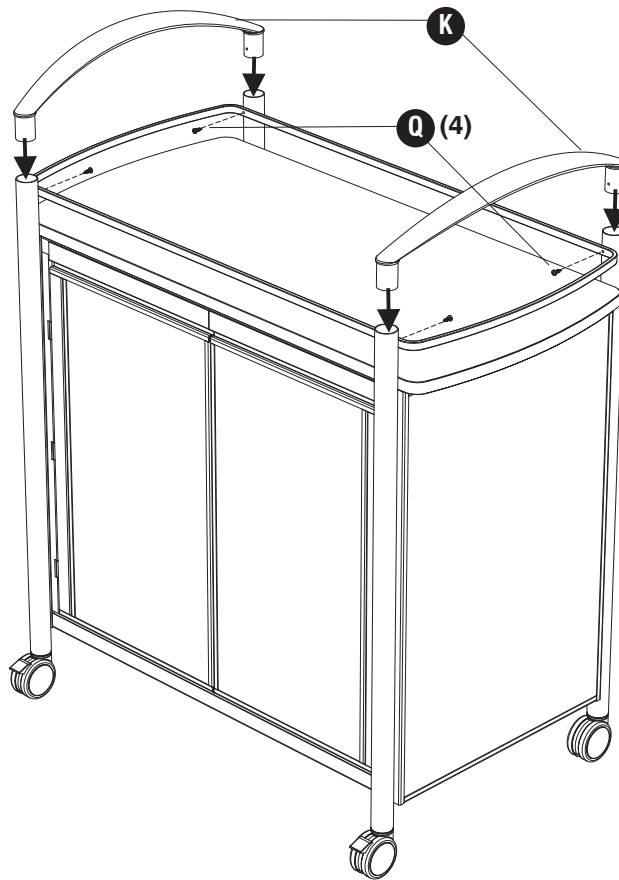

12

Engage all four supports

S'enclencher tous les quatre supports

Intertraba de los cuatro soportes

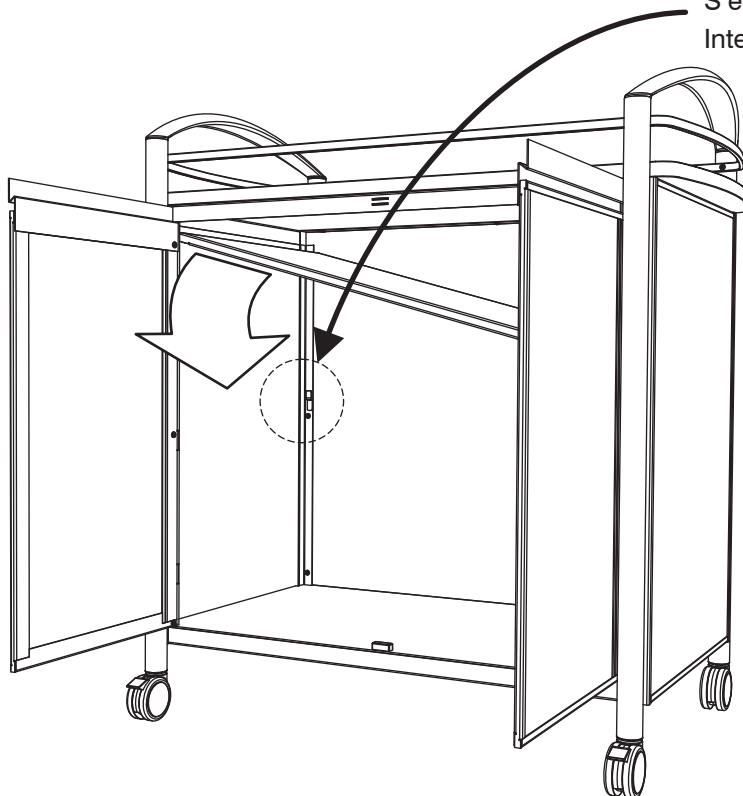

If doors have become misaligned, loosen door screws, realign doors, then tighten all door screws

Si les portes se sont mal alignées, desserrer les vis de la porte, réaligner les portes, puis serrez toutes les vis de la porte

Si las puertas se han convertido en mal alineados, afloje los tornillos de la puerta, realinear las puertas, luego apretar todos los tornillos de las puertas