

REFRIGERATED COFFEE TABLE WITH BT SPEAKER & WIRELESS CHARGING

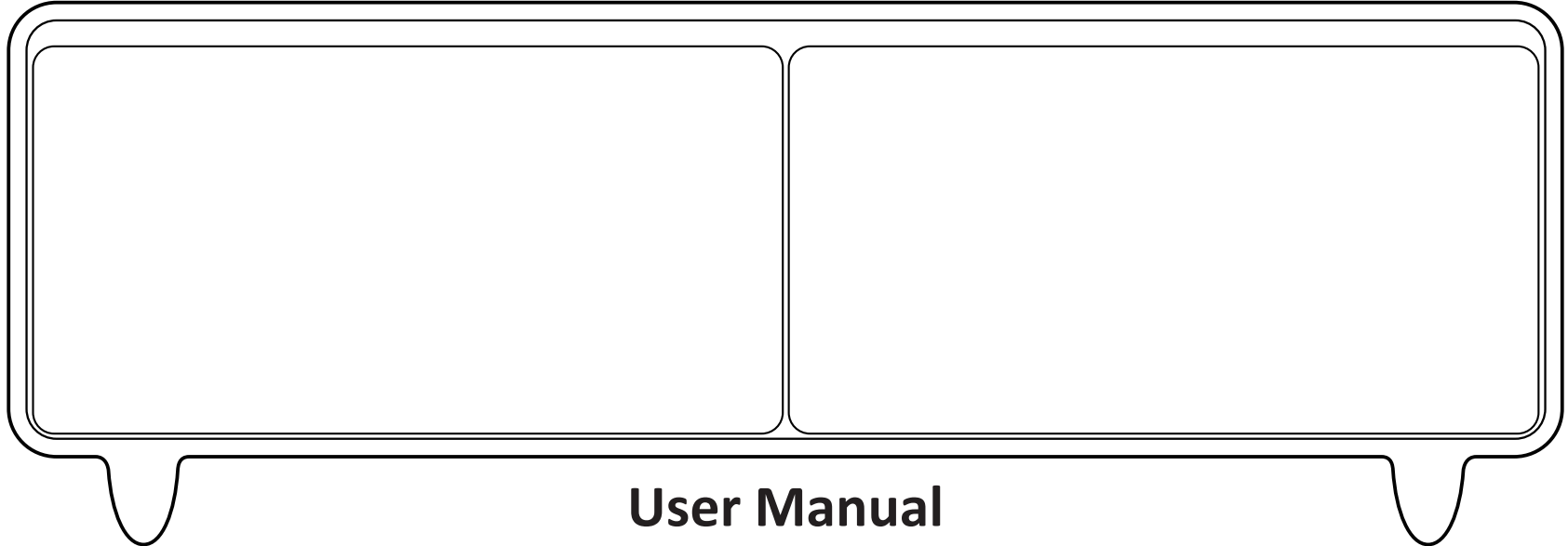

WARNING

READ UNPACKING INSTRUCTIONS CAREFULLY. YOU MUST LEAVE THE COFFEE TABLE SITTING TOPSIDE UP FOR A MINIMUM OF 2 HOURS PRIOR TO PLUGGING IN AND TURNING IT ON. DO NOT PLACE THE COFFEE TABLE UPSIDE DOWN, ON EITHER END OR ANY SIDES.



WARNING

THOROUGHLY READ ALL INSTRUCTIONS AND WARNINGS PRIOR TO FIRST USE. FAILURE TO DO SO MAY RESULT IN DAMAGE TO THE UNIT, PERSONAL INJURY AND/OR PROPERTY DAMAGE.

Use Video



go to <https://ismarttable.com/guide>
to watch use video.

- ⚠ • If the power cable is damaged, it must be replaced by the manufacturer, its service agent or similarly qualified persons in order to avoid a hazard.”
- ⚠ • “Children should be supervised to ensure that they do not play with the appliance.”
- ⚠ • “This appliance is not intended for use by persons (including children) with reduced physical, sensory or mental capabilities, or lack of experience and knowledge, unless they have been given supervision or instruction concerning use of the appliance by a person responsible for their safety.
- ⚠ • Do not store explosive substances such as aerosol cans with a flammable propellant in this appliance.
- ⚠ • This appliance is intended to be used in household and similar applications such as:
 - staff kitchen areas in shops, offices and other working environments;
 - farm houses and by clients in hotels, motels and other residential type environments;
 - bed and breakfast type environments;
 - catering and similar non-retail applications

⚠ • **WARNING:** Keep ventilation openings, in the appliance enclosure or in the built-in structure, clear of obstruction.

⚠ • **WARNING:** Do not use mechanical devices or other means to accelerate the defrosting process, other than those recommended by the manufacturer.

WARNING: Do not damage the refrigerant circuit.

⚠ • **WARNING:** Do not use electrical appliances inside the food storage compartments of the appliance, unless they are of the type recommended by the manufacturer

⚠ • Please accord to local regulations regarding disposal of the appliance for its flammable refrigerant and blowing gas. Before you scrap the appliance, please take off the doors to prevent children trapped.

⚠ • When disposal of the appliance, it must be done by the manufacturer or its service agent or a similarly qualified person in order to avoid fire and other hazard.

TABLE OF CONTENTS & SPECIFICATIONS

TABLE OF CONTENTS

- Unpacking the Sound Fridge
- Safety Precautions & Warnings
- Features
- Parts List
- Control Panel
- Fridge Operation
- Speaker Operation
- Charging Functions
- Daily Maintenance
- Transporting the Sound Fridge
- Trouble Shooting
- Warranty

SPECIFICATIONS

Consumption	0.38kWh/day	Packing Size	53.5" x 30.5" x 20"
Noise Level	36dB	Temp Control	Electric
Voltage	110V-120V/60HZ	Cooling Type	Compressor
Net Weight	135 lbs	Refrigerant/Wt	R600a/25g
Gross Weight	150 lbs	Volume	70L + 65L
Controlling	Electric	Drawer 1 Temp Range	37.4°F- 46.4°F
Size	51" x 28" x 18.25"	Drawer 2 Temp Range	42.8°F- 53.6°F
Wireless Charger	15W	USB/Type C	5V/2.1A
Speaker	Bluetooth	Speaker Watts	20W x 2

PREPARATION FOR USE – UNPACKING

1. Remove all packaging materials.

WARNING

Remove from foam base. Do not use while on foam base. Doing so may result in personal injury and/or property damage.

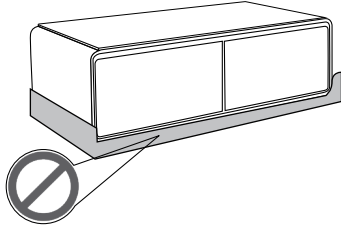

2. Peel off transparent film from surface of the table.
3. Ensure all accessories are included.



Coffee Table x 1

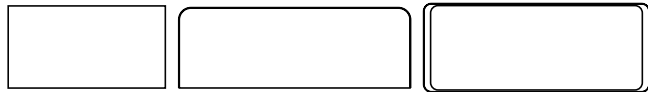

Manual x 1

Partitions x 4

Trays x 2

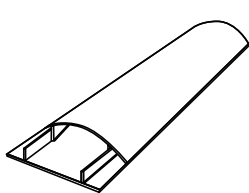

Cable Cover x 1

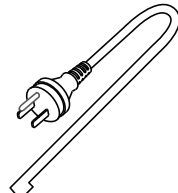

Power Cable x 1

4. Place table where it will be hooked up.

WARNING

- Place table so that there is more than 16-inches on the front side (speaker side) and at least 20-inches on the back side (furniture side).

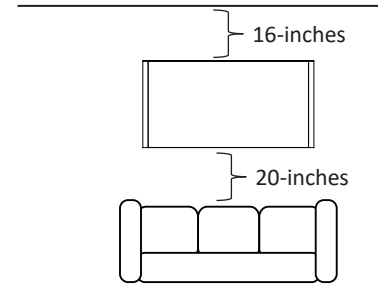

- Table should be on flat, solid surface.

5. Clean the unit before using (Refer to Maintenance Instructions).
6. **Do NOT connect the power cord to power source. Let unit sit for 2 hours.**
7. After 2 hours, it is ready to be plugged in and powered on.

WARNING





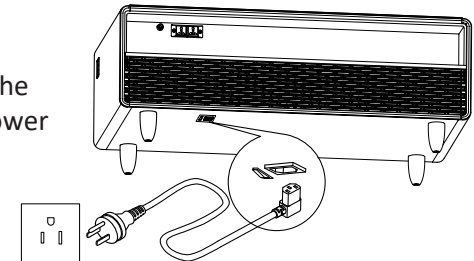

Total external electrical home appliances should not exceed 960W. Do not use an external patch.

WARNING

There is overload protection on the bottom of the unit. If the total power consumption exceeds 960W, the power supply will cut off automatically.



ELECTRICAL WARNINGS

-  Before initially powering on the unit, please install the cable cover to prevent any damage of the cable.
-  The power cord should be kept in firm contact with the power source. Failure to do so could result in property damage, personal injury and/or fire.
-  To avoid damage to the cable, please do not step on the cable.
-  Do not roll over the power cord when moving the Coffee Table.
-  When unplugging the Coffee Table, do not pull on the cable. Firmly grasp the plug to remove from power source.
-  Before cleaning, repairing or replacing any parts, unplug the Coffee Table to avoid electric shock.
-  If the power cable or plug has any damage, do not use.

POWER SUPPLY WARNING

-  Coffee Table should be powered by AC 110V. If the voltage fluctuation is out of range, it may cause unit failure, property damage and/or personal injury.

GROUNDING WARNING

-  Independent power source should be used and be grounded. Coffee Table power cable is equipped with grounded plug and socket. Never remove or cut off the third pin.

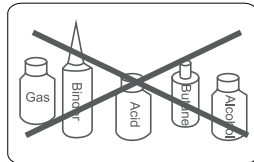



WARNING!

No repairs or modifications shall be made to the Coffee Table. Failure to adhere to this warning may result in property damage, personal injury and/or death.





NOTE: New refrigerant type R600a must be repaired by a trained professional. Fire may occur during repair, if not handled properly. Damaged units should be recycled by a professional company or as detailed by the State of residence.



STORAGE WARNINGS

-  Coffee Table should not be used to store blood or other biological products.
-  Coffee Table should not be used to store any products that are inflammable, explosive or dangerous, as well as any chemicals.

WIRELESS CHARGER

-  If the device is equipped with a thick, protective shell, a metal protective shell or a battery shell, the charging efficiency may be affected. Remove shell and try again.
-  The wireless charger may generate heat when charging. If the battery overheats, the software may limit the charging. It will begin charging once the temperature drops.
-  When the wireless charger is in use, the USB charging should not be utilized. When using the USB charging, wireless charger should not be used.



110V POWER SUPPLY

-  • Keep liquids away from socket. Do not use wet cloth to clean. Water is a conductor, contact with the socket may lead to property damage, personal injury, including electric shock.
-  • The rated power of connected appliance cannot exceed 960W. Overloading will lead to over -heating and can cause property damage and/or personal injury.
-  • Do not use an external patch.

USB





-  • Keep liquids away from USB ports. Do not use wet cloth to clean the ports.

SPEAKER

-  • Coffee Table should not be in contact with equipment that is damp, hot or has a strong magnetic or electric current. If damage occurs, disengage the Coffee Table from power supply and remove those items before powering back up.
-  • Use only on a horizontal and stable surface with good ventilation.

ENVIRONMENT

-  • Coffee Table should be placed far away from any heat source and out of direct sunlight.
- Coffee Table should be placed in a well ventilated area, with at least 16 inches around all sides.
- Do not place the Coffee Table in areas that are damp or where the unit may encounter water.

-  • Do not place power sockets, regulated power supplies or small appliances on the Coffee Table.
- Do not put unstable objects on the Coffee Table to avoid damage to top.
-  • Use caution when placing objects with liquid on table. Spilling liquid can result in property damage, personal injury and/or electric shock.
-  • Do not store gas or any other flammable materials in or near the Coffee Table to avoid possible fire hazard.
-  • If there is any gas or other flammable material leak around the unit. Close the gas valve and open all doors, and windows immediately. **DO NOT PULL OR TOUCH THE COFFEE TABLE UNTIL AREA IS CLEAR.**



WARNING!
Do not use Coffee Table if it has been subjected to any shock or damage. Do NOT attempt to repair the Coffee Table. Repairing or modifying your Coffee Table may result in property damage, fire, personal injury and/or death.

REFRIGERATED DRAWERS

The Coffee Table is designed with two refrigerated drawers that can be independently controlled for two zones of temperatures. Both drawers come with partitions and trays to organize all your favorite beverages and snacks.

NOTE:

- Only store fresh food in the Coffee Table.
- Do not store foods that require colder environments.
- Do not put hot food into the Coffee Table, as it will increase the temperature inside the unit, affecting items.
- Do not open the drawers frequently or leave them open as it will also cause the temperature to rise.
- Make sure items are securely sealed to avoid excess moisture. This will help keep your Coffee Table clean and free of odors.

HIGH EFFICIENCY COMPRESSOR

The Coffee Table is equipped with a high efficiency compressor to keep your unit working at optimum performance.

110V POWER SOCKETS

The Coffee Table is equipped with 110V power sockets, to supply power to other devices. The power sockets have a separate safety switch to detect high input or overload. If the safety switch detects either, it will cut off power.

CHARGERS

There are three types of chargers, one 10W wireless charger located on the top, two USB Type A chargers which are located on the backside.

BLUETOOTH SPEAKER v5.0

Equipped with Bluetooth v5.0 technology, the transmission distance is 33 feet. It can easily connect to cell phones, computers, laptops or your TV.

ATMOSPHERE LIGHT

Built in atmosphere lighting provides rich color and ambience.

PARTITION STORAGE

In order to more effectively utilize the storage space, there are two partitions and one tray in the each drawer allowing for more flexible use.

REMOVABLE DOOR SEAL

The door seal ensures long lasting use of the refrigerated drawers. It is removable so it can be easily cleaned to help reduce energy consumption.

SHELF STORAGE

Designed with shelf storage to place small items to help personalize your space.

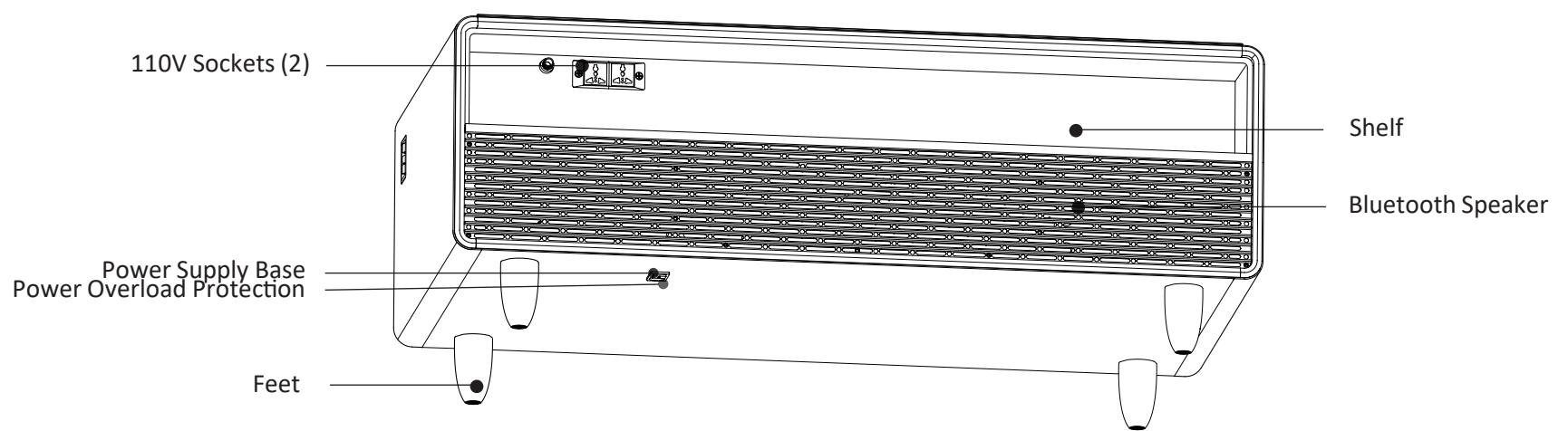
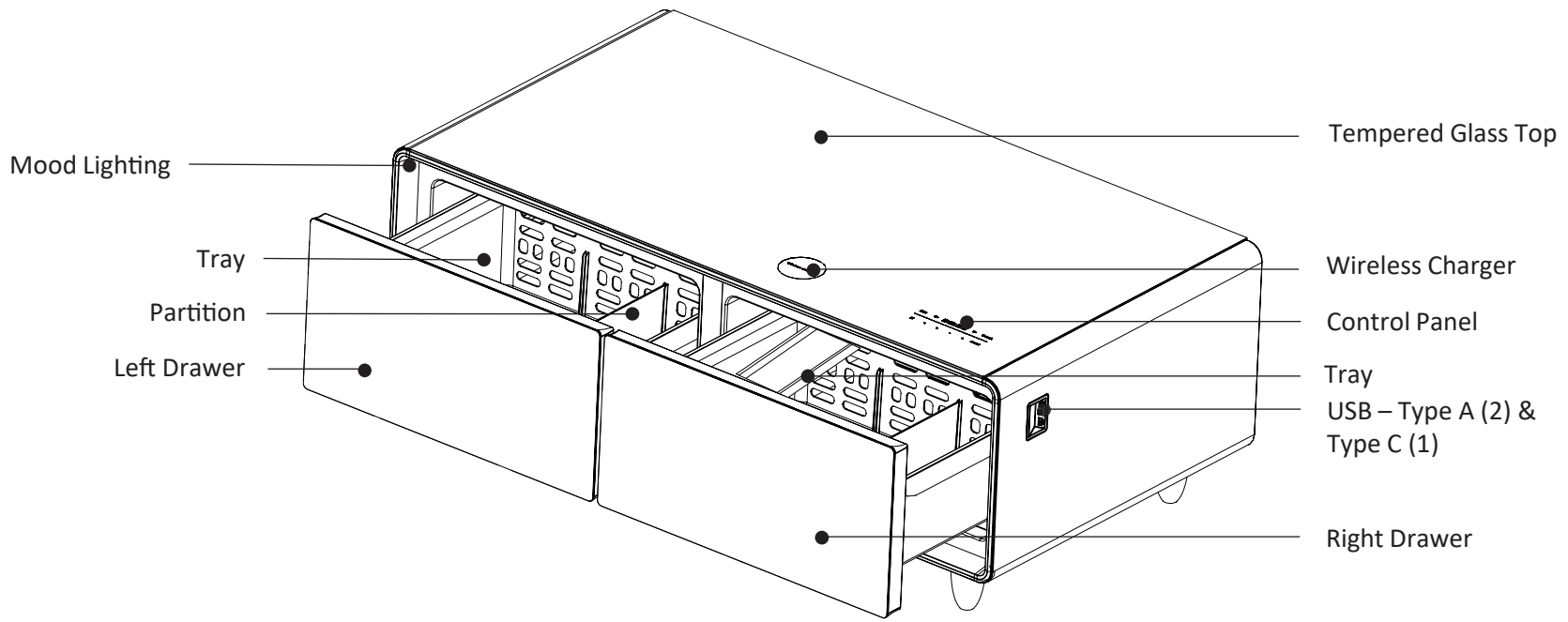

PARTS LIST

The Control Panel is divided into two sections, split by the horizontal line. The area above the line controls the refrigeration and the area below the line controls the speaker.

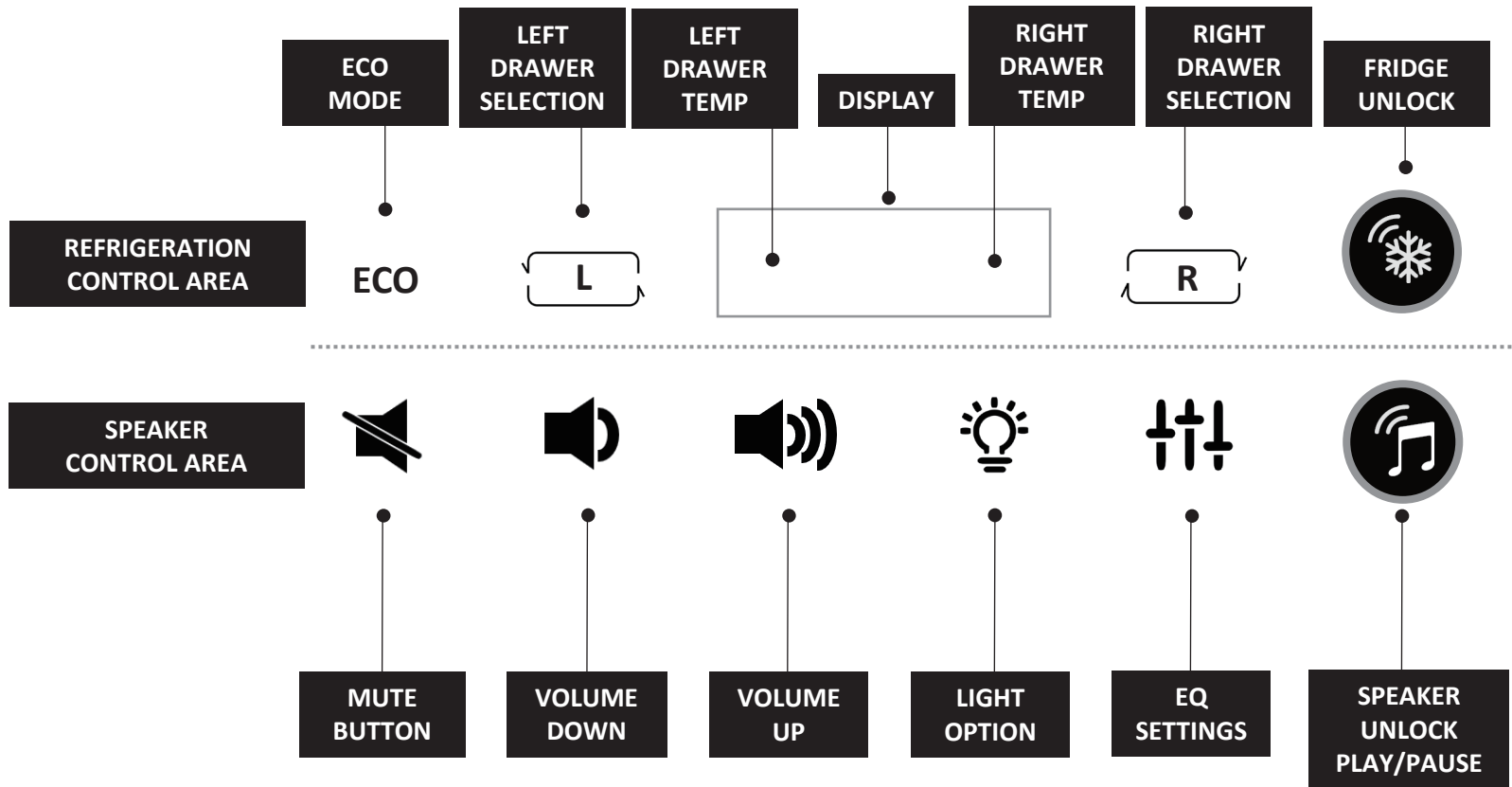

REFRIGERATION CONTROL PANEL

After the initial powering on of the Coffee Table, it will automatically enter unlock mode. If there is no operation within 10s the control panel will automatically lock.

When control panel is in lock mode, no information will be displayed.

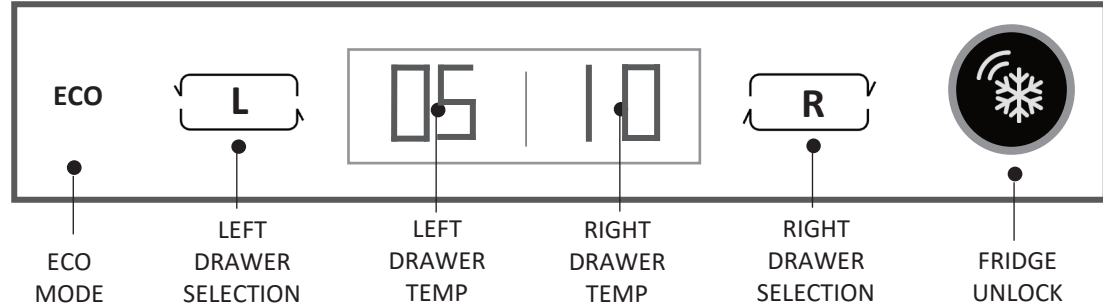

NOTE: No buttons can be used in Locked Mode except the Unlock buttons.





ACCESSING REFRIGERATION SETTINGS

- Double tap on the Fridge Unlock  icon. Current drawer temperatures will appear on the Display.

LEFT DRAWER ADJUSTMENT

- Double tap on the Fridge Unlock  icon. After unlocking the control panel, tap on Left Drawer  icon.
- Tap on the Left Drawer  icon to until preferred temperature is displayed.

RIGHT DRAWER ADJUSTMENT

- Double tap on the Fridge Unlock  icon. After unlocking the control panel, tap on Right Drawer  icon.
- Tap on the Right Drawer  icon to until preferred temperature is displayed.

ECO MODE

- Tap ECO icon. Display will show ECO. This will set both drawers to the most efficient power saving settings.

DOOR ALARM

- When a Drawer is opened, the temperature of the Drawers will show in the display. If the Drawer is left open, an alarm will beep to remind you to close the Drawer.

POWER OFF MEMORY

- When the Coffee Table is powered off, the Power Setting will be memorized and revert back to last setting when powered back on.

SPEAKER CONTROL PANEL

ACCESSING SPEAKER SETTINGS

- Double tap on the Speaker Unlock  icon. Speaker will turn on and go into Bluetooth mode.
- On your device, go to Bluetooth settings and select device “T-bar”. Speaker will announce when device has been paired. Once paired you can utilize the Speaker Control Panel.



USING THE ATMOSPHERE LIGHT

Press  icon to turn light on. To turn off, press  icon again.

MUSIC PLAY/PAUSE

Double tap the Speaker Unlock  icon to access the Control Panel, then tap the Speaker Unlock  icon again to Play/Pause music.

MUTE MUSIC

Double tap the Speaker Unlock  icon to access the Control Panel. Press the Mute  icon. Note: the music will be muted but the song will continue.

VOLUME ADJUSTMENT

Double tap the Speaker Unlock  icon to access the Control Panel. There are 16 levels of volume.

Tap the Volume Up  icon to increase volume.



Tap the Volume Down  icon to decrease volume.

LIGHT OPTION

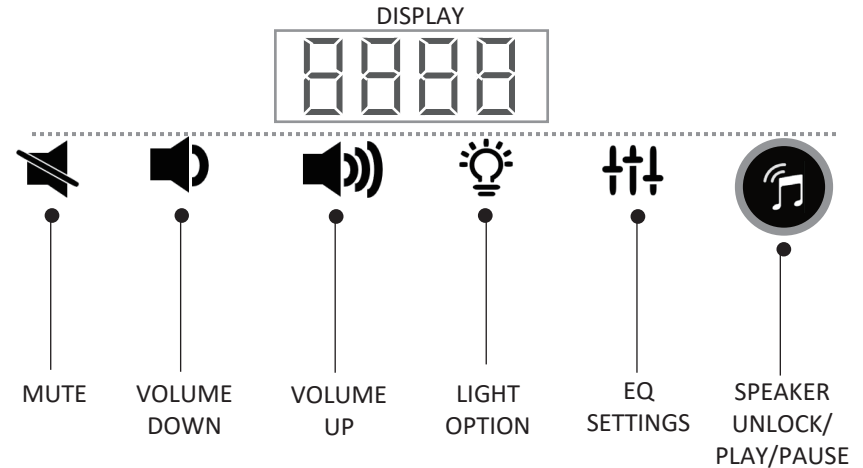
Double tap the Speaker Unlock  icon to access the Control Panel. Press the Light Option  icon to turn light on. Press the Light Option again to turn light off.



EQ SETTINGS

Double tap the Speaker Unlock  icon to access the Control Panel. Tap the EQ Settings  icon and continuing tapping until desired preset EQ option is displayed on the Display. Preset options include:



AUTO
FILM
JAZZ
POP
ROCK

NOTE: If you have the light option on, depending on which EQ setting you choose, the light effects will change.

SPEAKER LOCK

If there is no operation within 10 seconds, the Speaker Control Panel will automatically lock.

SPEAKER OFF

Double click the Speaker Unlock  icon to access the Control Panel. Long press the Speaker Unlock  icon until speaker turns off. Display panel will show OFF.

WIRELESS CHARGING

NOTE: Wireless charging feature only works for devices that are equipped with wireless charging.

- Wireless charging feature is enabled once the table has been plugged in.
- Try to center device when placing on wireless charger.
- Make sure there is no metal between the charger and the phone to avoid overheating.
- If the charging surface is overheating, remove device from charger.
- Case may need to be removed to utilize wireless charger.
- When using the wireless charger, USB charger should not be used.

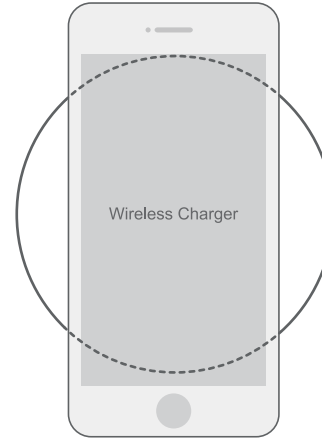

Voltage	12V Input
Output	15W (max)
Sensing Distance	=<4mm
Work Frequency	105-205KHz
Work Temperature	14°F - 149°F
Work Humidity	10%RH - 75%RH

USB-A or TYPE C CHARGING

There are two USB-A chargers that can connect devices to the speaker and charge device.

There is one Type C charger that can connect devices to the speaker and charge device.

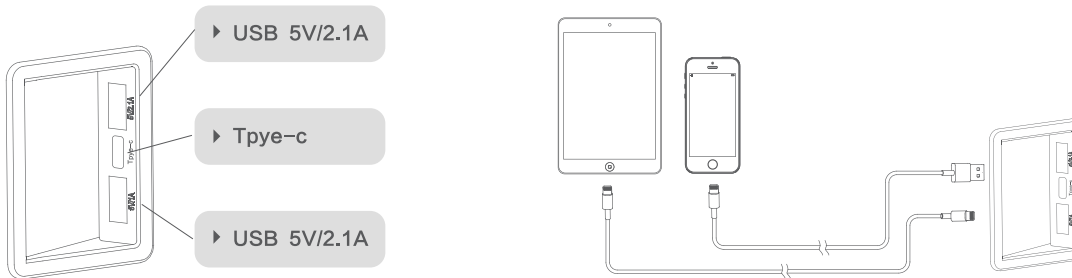

110V POWER

There are two 110V sockets to power other devices with a jack current of 10A and a rated power of 960W. It can meet the power of three pin electrical devices.

- ⚠ Do not drop water in or let water gather in or around sockets.
- ⚠ Do not connect appliances with rated power over 960W.

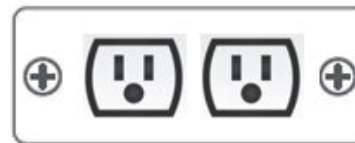

CLEANING THE COFFEE TABLE

Clean drawer regularly. Do not leave old food stored in drawer.

1. Unplug the Coffee Table prior to cleaning.
2. Do not disassemble the unit with force, as it may cause damage.
3. Clean the unit with a soft, damp cloth. Dry unit with soft cloth. Do not use too much liquid as it may cause deformation, and or short circuit the unit. No free-flowing liquid should be used.
4. Clean drawer with soft, damp cloth and mild detergent. Dry with soft cloth.
5. Inspect the unit after cleaning. Do not use if any damage is found.
6. Make sure unit is completely dry before plugging back in.

NOTE: Be sure to clean the door seal thoroughly to ensure a long-lasting, good seal and preserve power consumption.

- The Coffee Table is heavy. Protect floor when cleaning the unit.
- When moving the Coffee Table, do not shake.
- Do not use hot water to clean glass top or any other part of the Coffee Table, including the drawers, trays and partitions.

REMOVING THE DRAWERS FOR CLEANING

1. Before removing the drawer, remove the trays and partitions out.
2. Pull drawer as far as it will go, then lift and pull gently.
3. Clean drawer, trays and partitions can be washed.
4. Clean door seals.
5. Dry all parts before placing the drawer back into the unit.

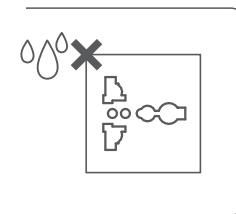
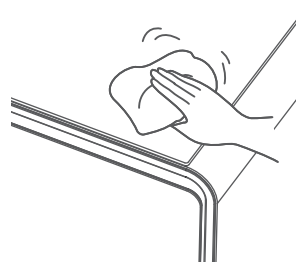

! WARNINGS

Do not spray water onto or into the unit.
 Dry completely before connecting to power source.
 Do not use the following substances:

- Acidic or alkaline solutions or powders
- Benzene, sodium bicarbonate, alcohol, carious acids or petroleum
- Abrasive cleaners
- Abrasive sponges or hard brushes
- Hot water

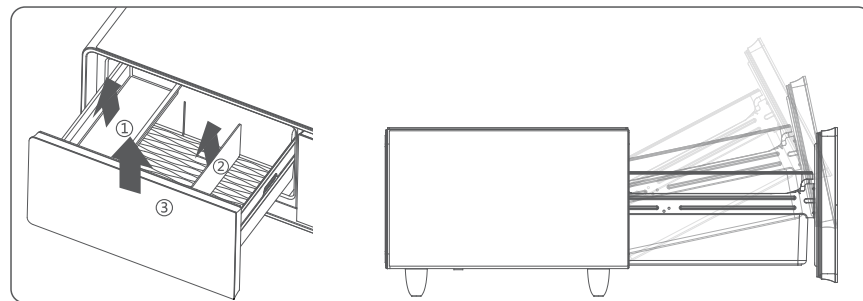

Transporting the Coffee Table

Unplug the Coffee Table.

Secure the trays and partitions.

 Do not tilt or stand the Coffee Table up. The maximum incline should be less than 45-degrees. Inclining more can cause damage to the refrigeration system.

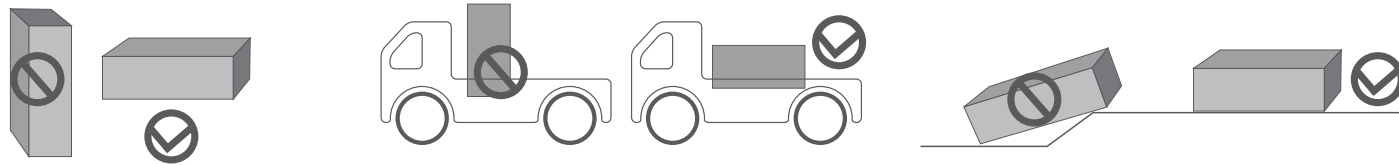

Refrigerated drawer will stay cool for 1-2 hours without power. However, once power has been shut off, do not open the drawer again to preserve the inside temperature.

 Any power failure can cause temperatures to rise and shorten lifespan of food and quality of food. If the Coffee Table has been without power for an extended period of time, unplug the unit and thoroughly clean.

 If leaving your home for an extended vacation, please power off if any perishables are being stored in the unit.

TROUBLE SHOOTING

FAULT	CAUSES	SOLUTION
Power light is on, compressor is working but making buzzing sound.	Power voltage is lower than 90V	local fluctuations exceed 90–120V , it is better to equip an AC-reguatro 2000V.
Compressor starts but stops after one minute, and then starts and stops ongoing.	Power voltage is higher than120V	
Compressor runs for a long time, but evaporator surface is frost free.	Leak Blockage	Professional inspection required.
There is frost on the surface but the compressor is working.	Too much frost on evaporator	Defrost
	Opening the drawers too much	Do not open drawers as often
	Drawers are too full	Remove some of the items
	Not enough ventilation	Move to a ventilated area
Unit does not work, refrigerator not cooling	Temp setting isn't good or sensor is missing	Professional inspection required.
	Fuse is blown	Replace fuse
Super high pitch noise	Input controlling circuit has fault	Professional inspection required.
	Unit is uneven	Adjust the unit
	Box fastener is loose	Fix the fastener
	Collision between pipes	Separate the pipes

- Condensation on the unit surface: High humidity may cause condensation, use dry cloth to wipe condensation.
- Hissing sound: That is just the sound of the refrigerator.