

# JZQ1670-2

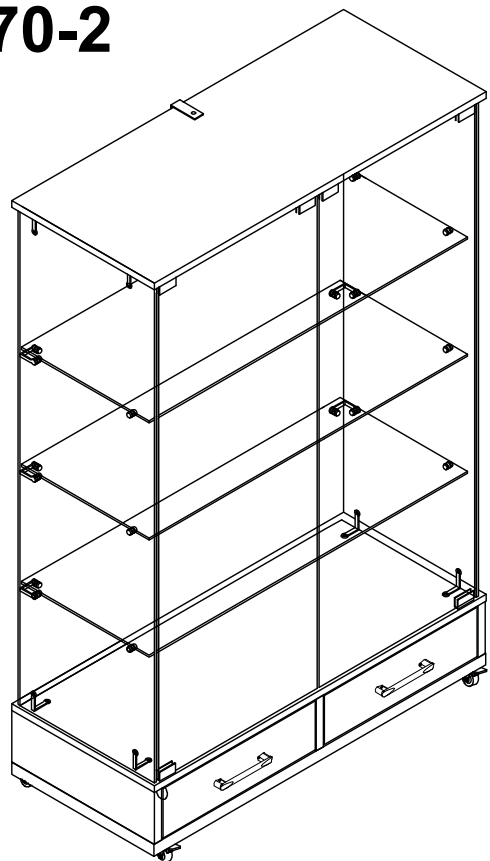

## Important Note:







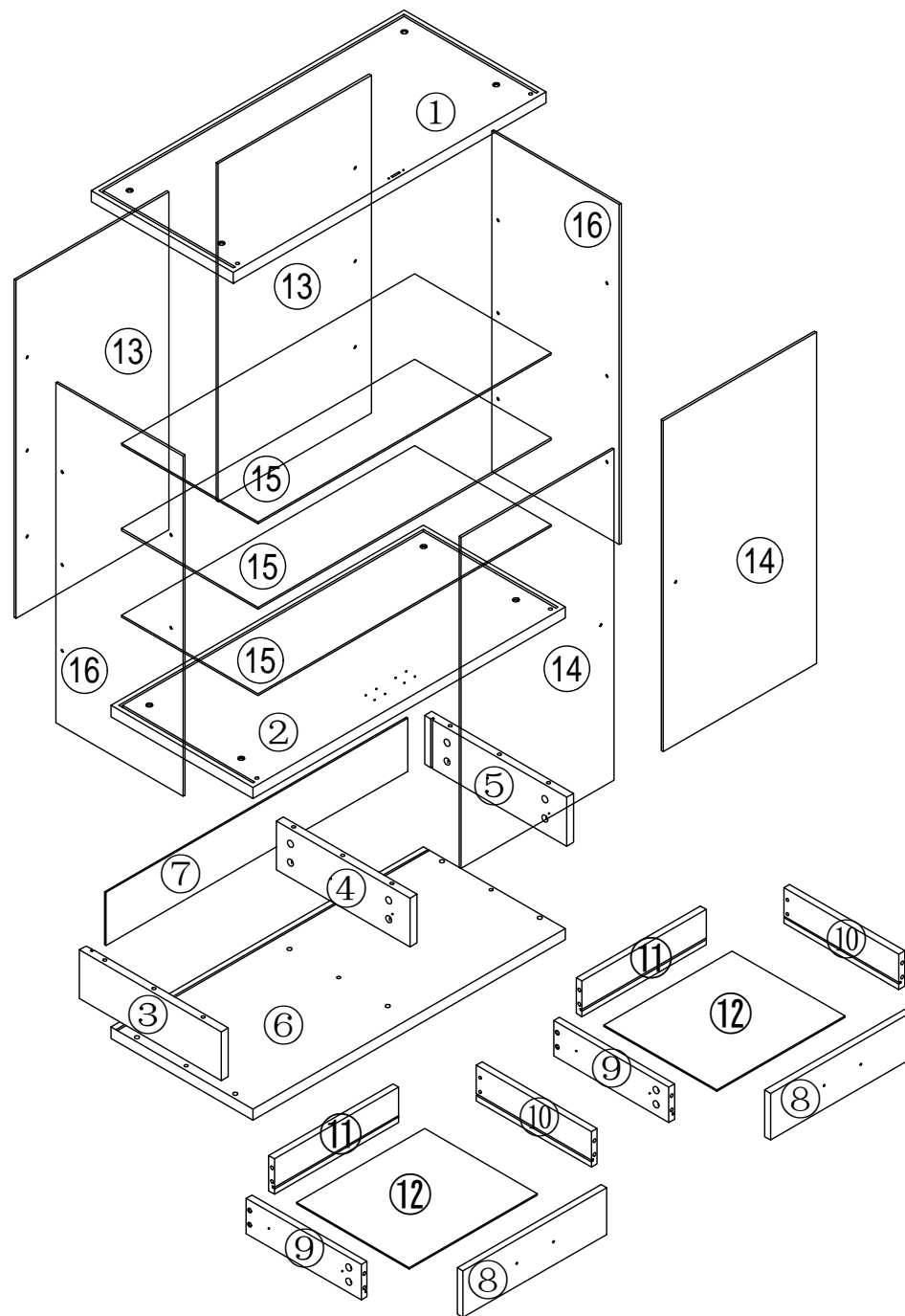



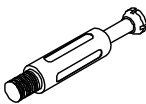

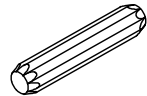
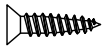
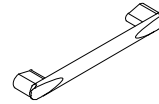
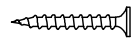

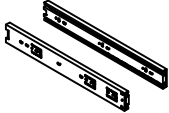



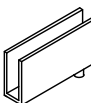
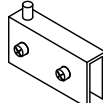
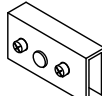

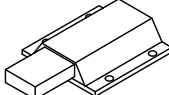





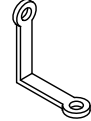
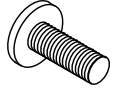
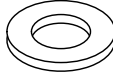

\*Place all parts on a clean and smooth surface such as a rug or carpet to avoid the parts from being scratched.

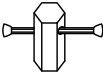
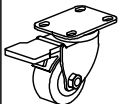
\*Kindly follow the assembly instruction step by step.

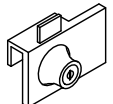
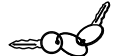
\*Don't tighten all screws until the cabinet is fully set-up.



TWO PEOPLE REQUIRED FOR ASSEMBLY

PART LIST											
 A x20	 B x20	8*40  C x6	3.5*14  D x16	 E x2	3.5*35  F x8						
4*18  G x4	300mm  H x2SET	 I <sub>1</sub> x1	(ANTI-TIPPING DEVICE)			 I <sub>2</sub> x1	 I <sub>3</sub> x1	 I <sub>4</sub> x1			
 J <sub>1</sub> x2	 J <sub>2</sub> x2	 J <sub>3</sub> x2	 J <sub>4</sub> x4	 J <sub>5</sub> x2	 J <sub>6</sub> x12	 M3*12MM J <sub>7</sub> x8	 K x2SET.	 REMOTE CONTROL	 CABINET LIGHT	 ASSEMBLY INSTRUCTIONS	
 L x14	 M x26	 N x60	 O x8	 P x18	 Q x8						
 R <sub>1</sub> x1	 R <sub>2</sub> x1	 S <sub>1</sub> x4	 S <sub>2</sub> x18	 T <sub>1</sub> x1	 T <sub>2</sub> x1	 T <sub>3</sub> x2	 T <sub>4</sub> x1	 T <sub>5</sub> x1	 U <sub>1</sub> x2	 U <sub>2</sub> x2	 U <sub>3</sub> x2

# TWO PEOPLE REQUIRED FOR ASSEMBLY

1

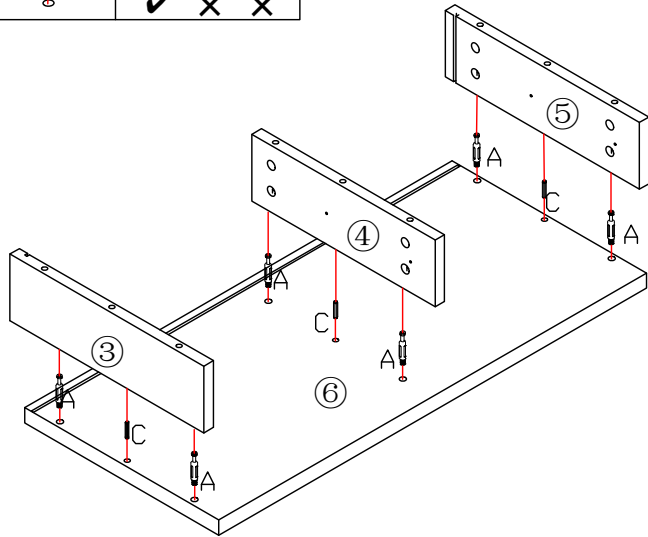
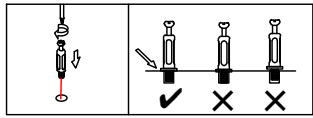

2

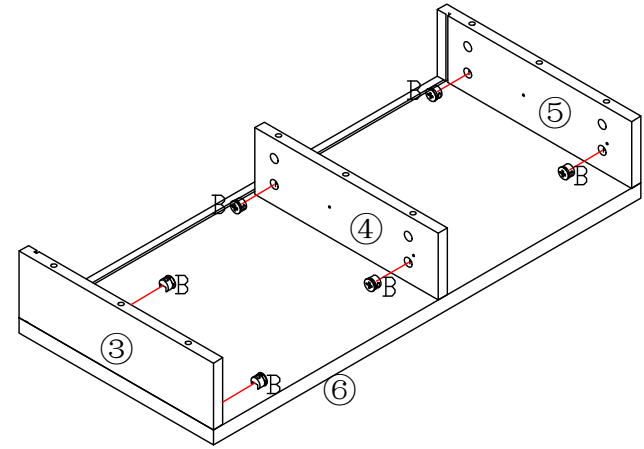
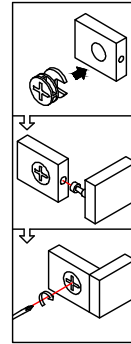

3

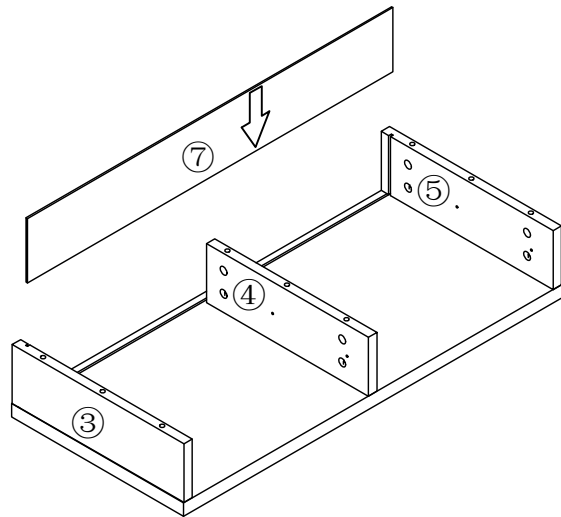

4

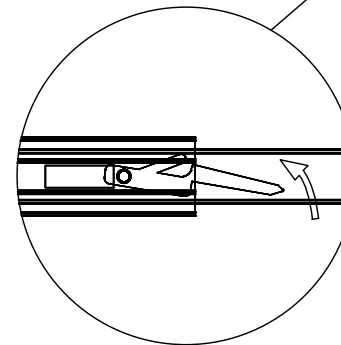

Taking the inner fixing rail off, please press dismounting rod.



H1



H2

# TWO PEOPLE REQUIRED FOR ASSEMBLY

5

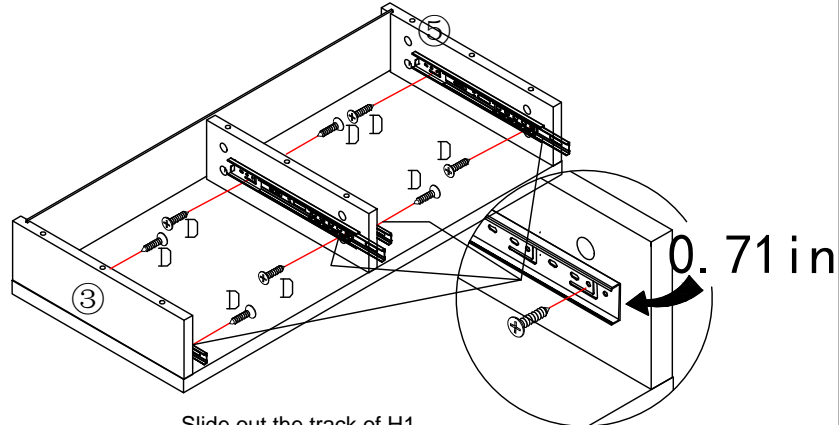

Slide out the track of H1

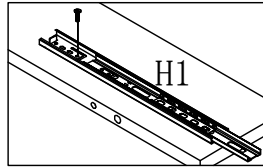
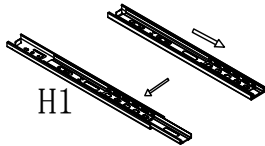
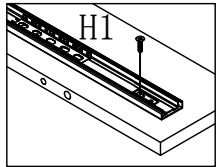

With the slide rail fully closed, secure the mounting hole at a position 0.71in from the edge of the board.

Align with the second hole and tighten the screw.

6

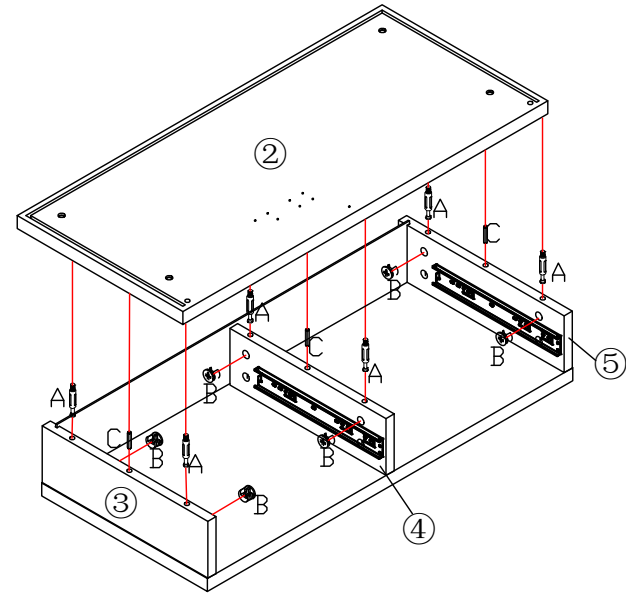

7

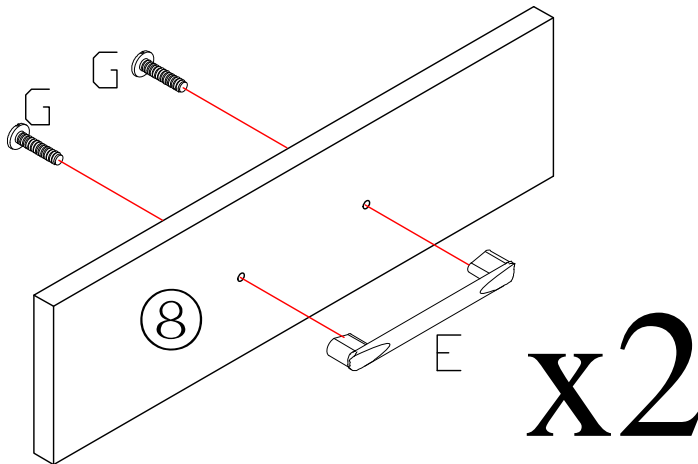

8

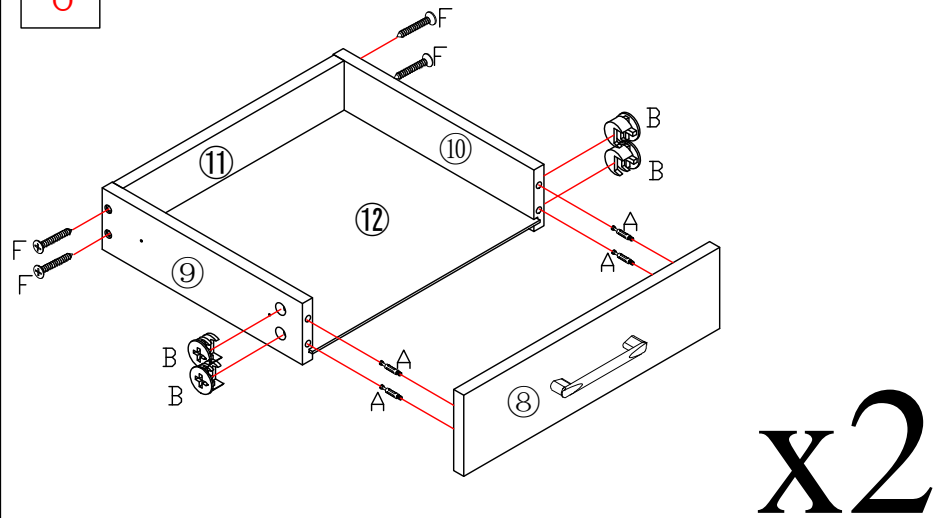

TWO PEOPLE REQUIRED FOR ASSEMBLY

9

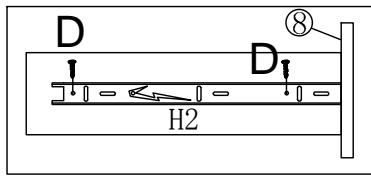

Align the H2 rib with the panel edge to match the hole position for the D-screw.

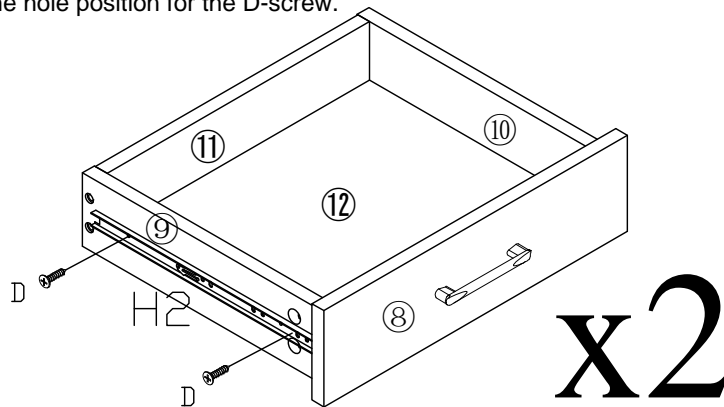

10

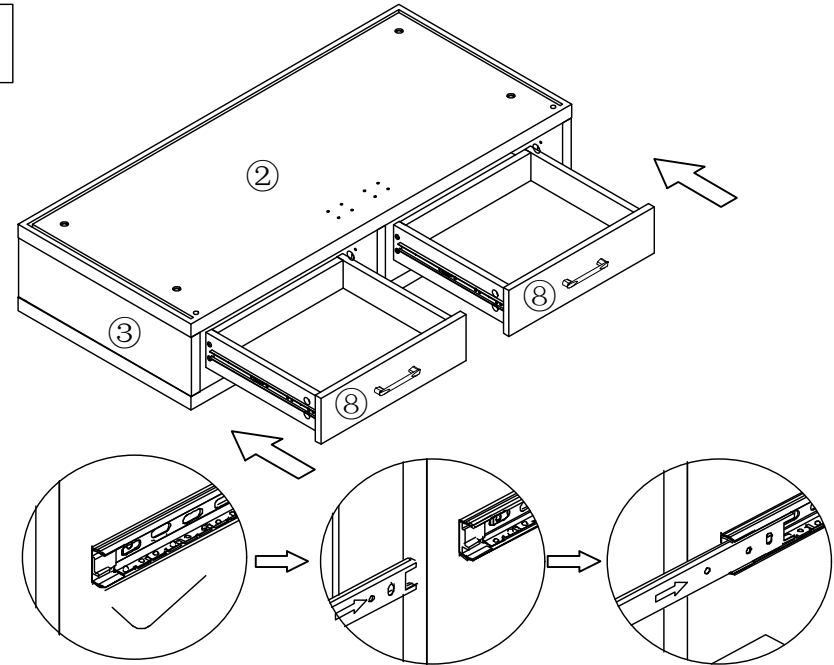

11

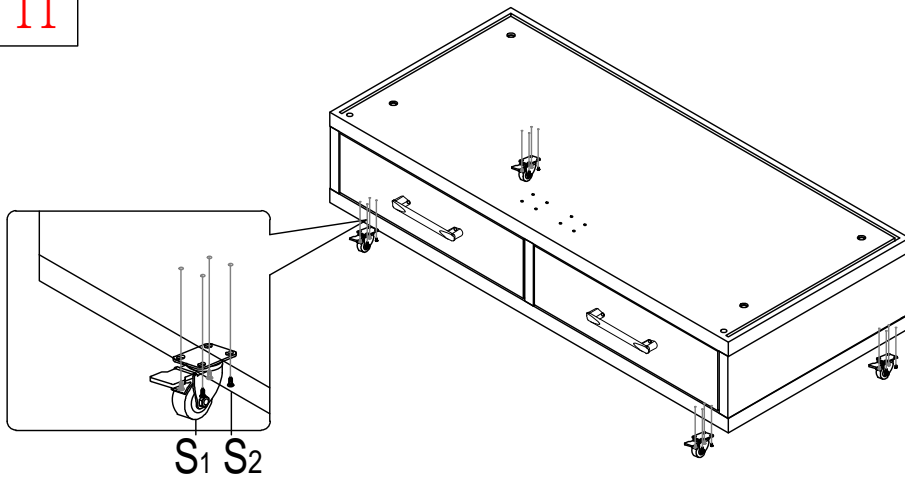

Attach the wheel parts [S1] to [6] plate.

12

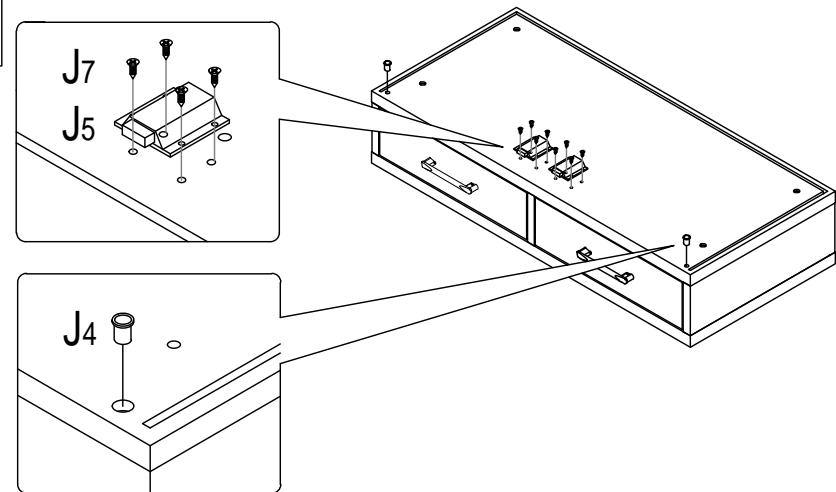

Attach the door holder [J4] to the [2] plate. Use the Phillips screwdriver [R] and attach the door holder [J5] to the plate [2] with the screws [J7].

# TWO PEOPLE REQUIRED FOR ASSEMBLY

13

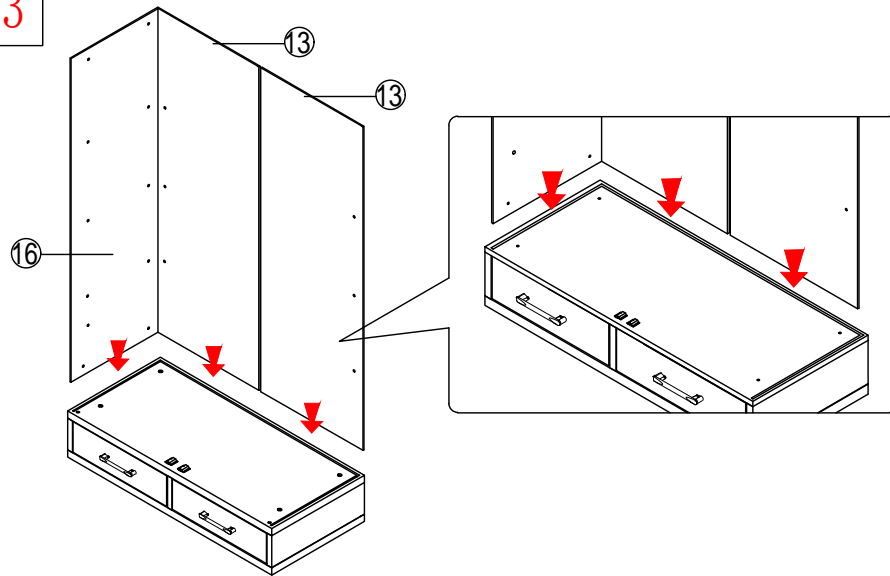

Insert the glass of [ 16 ] and [ 13 ] into the groove of [ 2 ] base plate.

14



Stick part [N] on both sides of the corresponding hole in the glass.

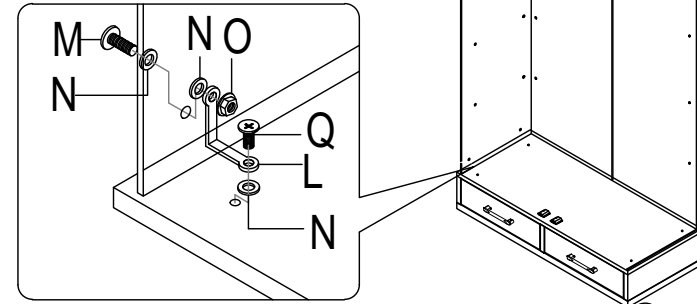

Align Fixing Parts [L] into the screw hole of the base plate [ 2 ], Temporarily tighten with screws [Q]. Use screws [M], washers [N], nuts [O] in order in the hole (lead hole) on the glass (side), temporarily tighten fixing parts [L] and adjust the position. Finally, tighten all screws [M].

15



Stick part [N] on both sides of the corresponding hole in the glass.

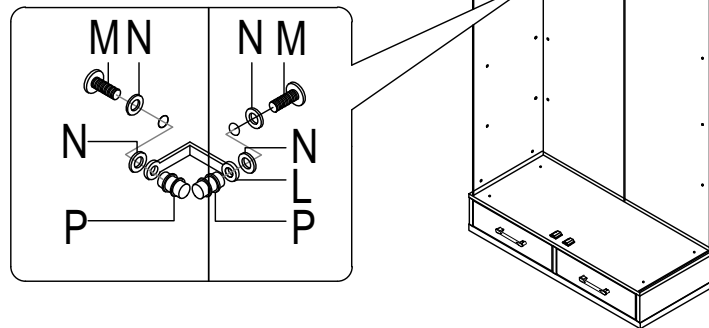

In the screw hole of the glass (side) Fixing parts [L], Temporarily tighten with dowels [P]. Use screws [M], washers [N], dowels [P] in order to temporarily tighten fixing parts [L] and adjust the position. Finally, tighten all screws [M].

16

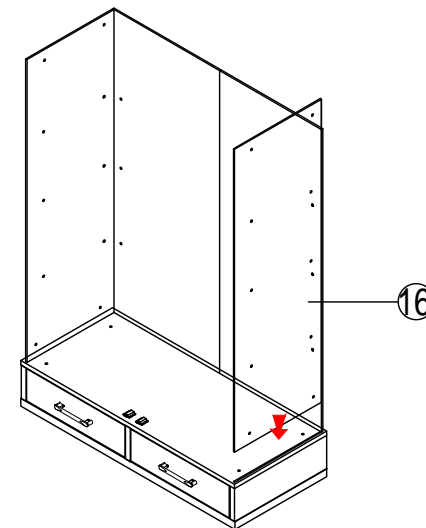

Fit the glass (side) into the groove in the base plate.

TWO PEOPLE REQUIRED FOR ASSEMBLY

17

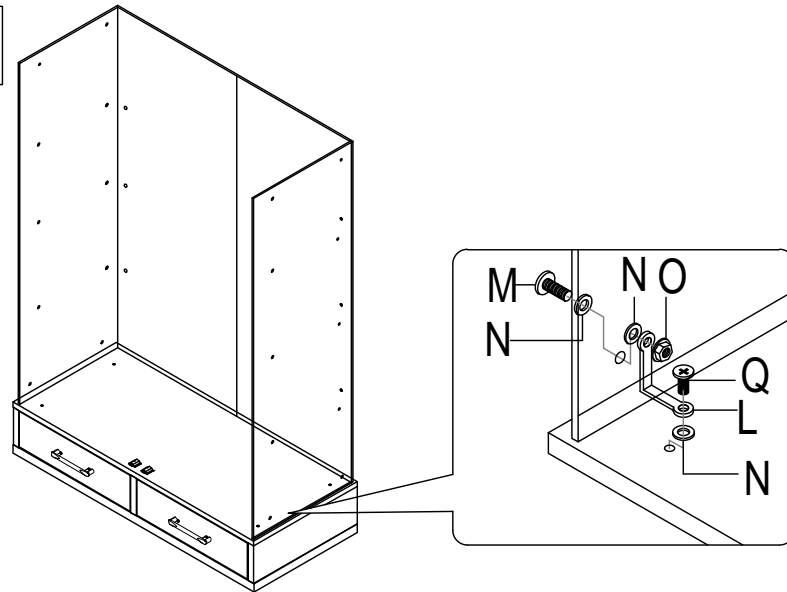

Same operation as step 14.

18

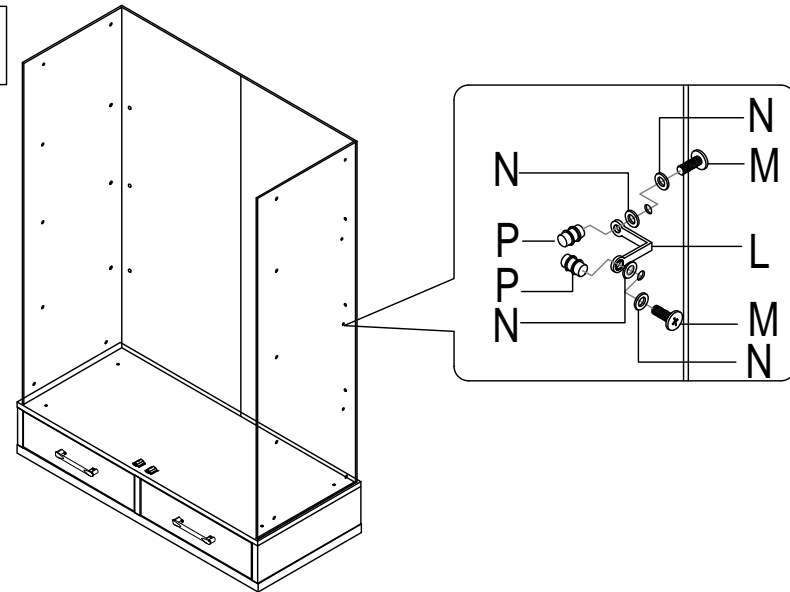

Same operation as step 15.

19

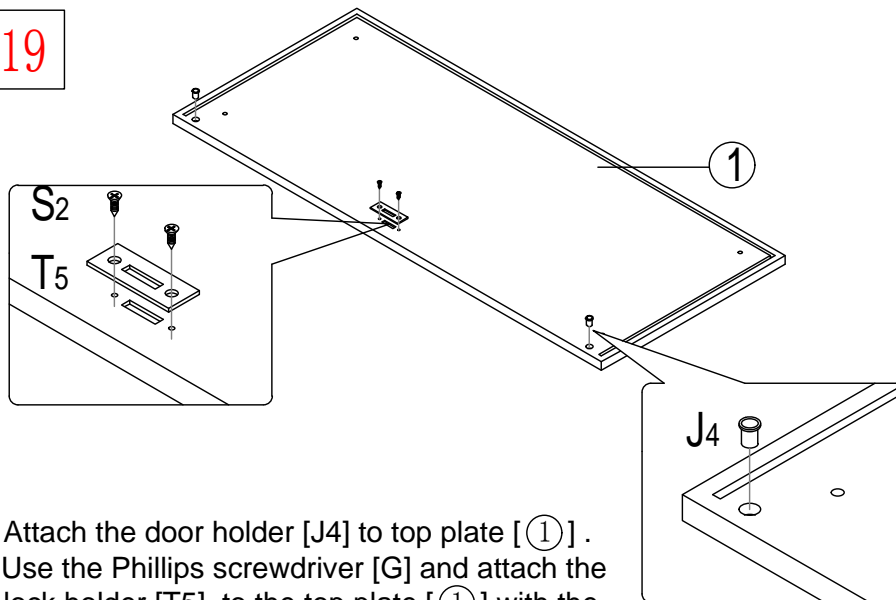

Attach the door holder [J4] to top plate [①]. Use the Phillips screwdriver [G] and attach the lock holder [T5] to the top plate [①] with the screws [S2].

20

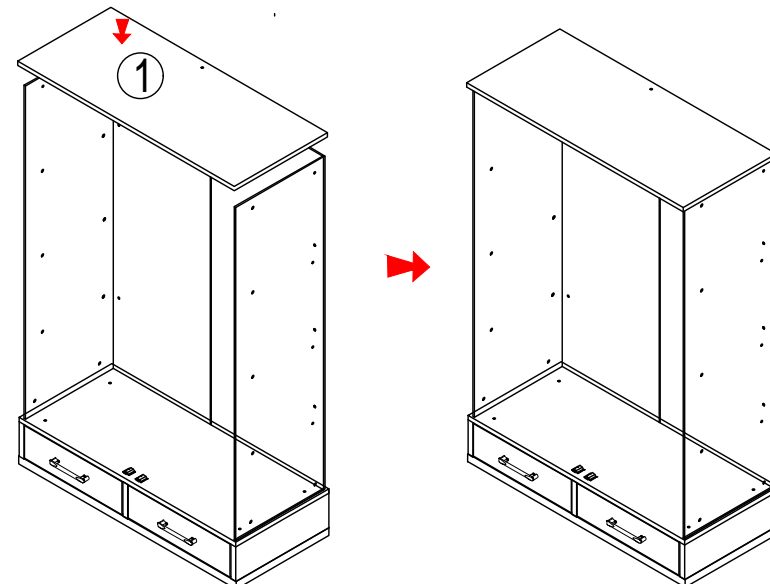

Insert the groove of the top plate into the glass and install it.

TWO PEOPLE REQUIRED FOR ASSEMBLY

21

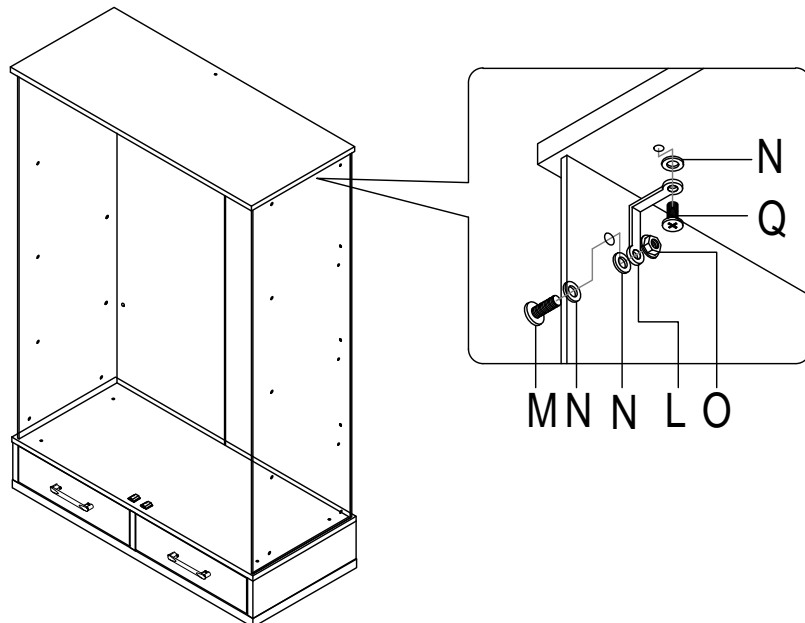

Same operation as step 14.

22

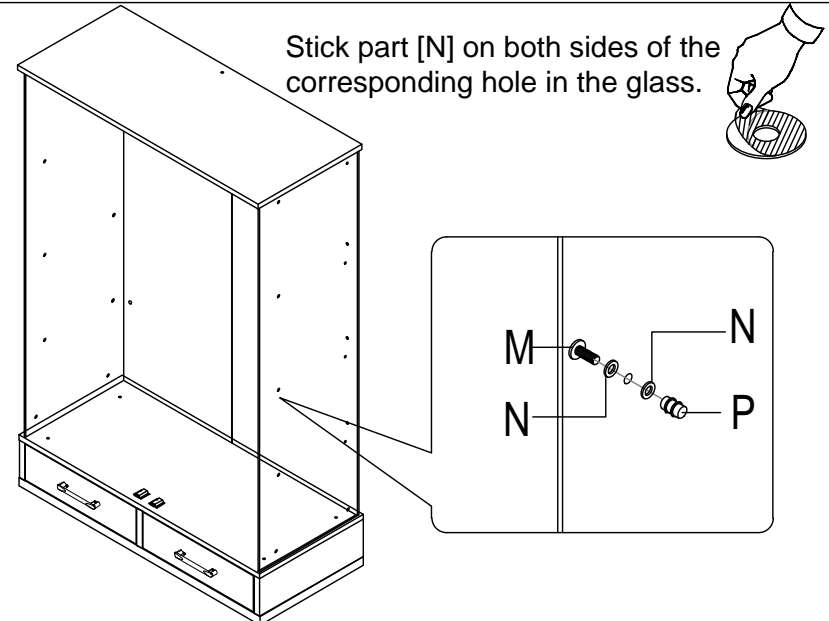

Use the washer [N] screws [M] to install the dowel [P] into the hole open on the side (lead hole).

23

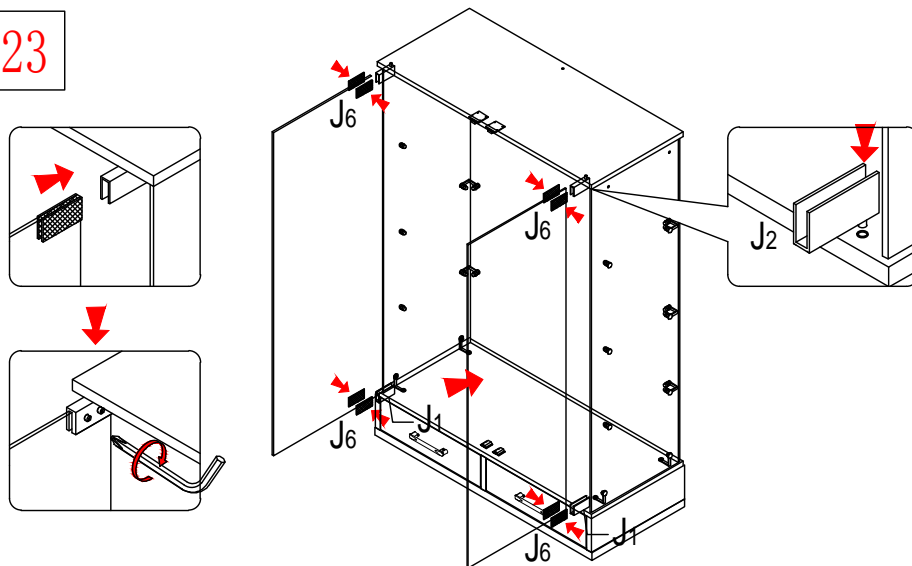

Door receiving metal fitting (lower part) [J1] cushion [J6] and Door receiving metal fitting (upper part) [J2] cushion [J6] Slide and insert, tighten screws to fix.

24

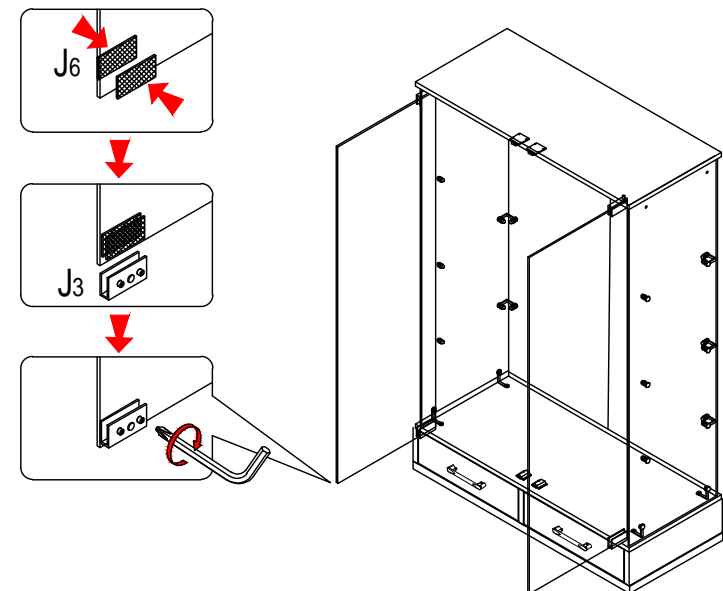

Use magnet [J3] and cushion [J6] to tighten screws to fix.

TWO PEOPLE REQUIRED FOR ASSEMBLY

25

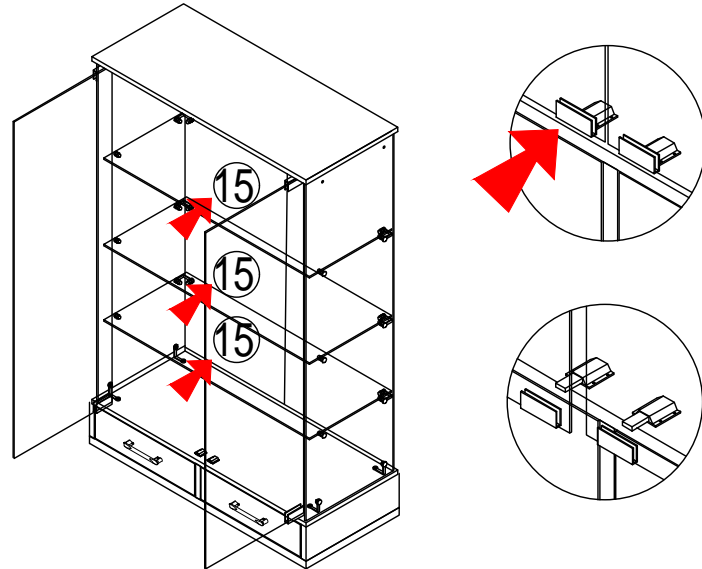

Put the glass shelf board into the main body while tilting it diagonally and place it on the dowel.  
Adjust component [J3] to the appropriate position

26

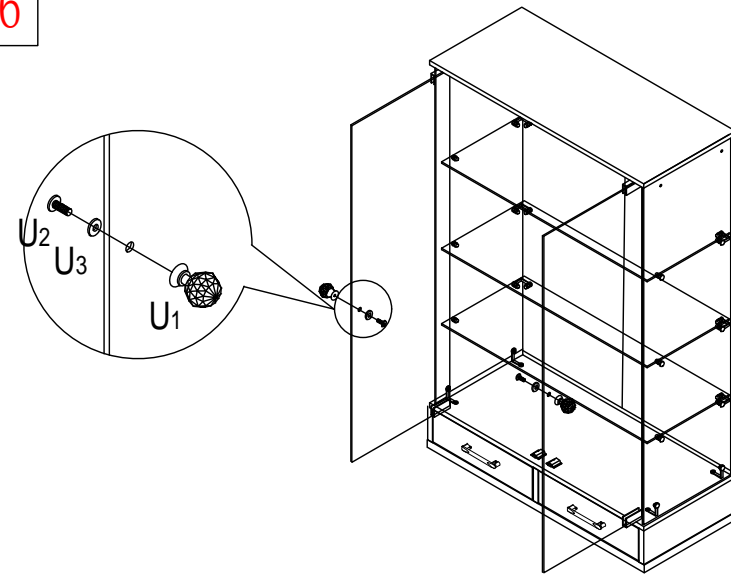

27

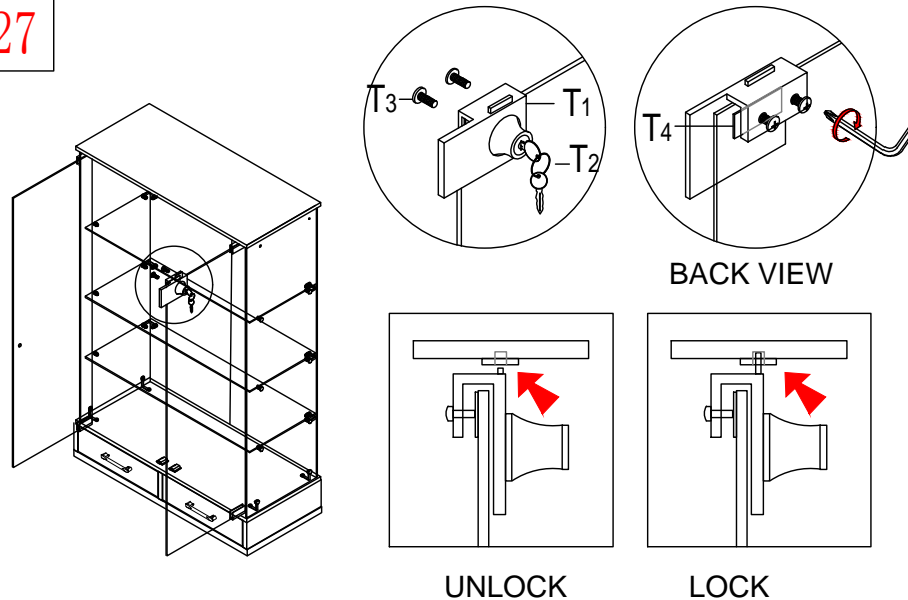

UNLOCK

LOCK

28

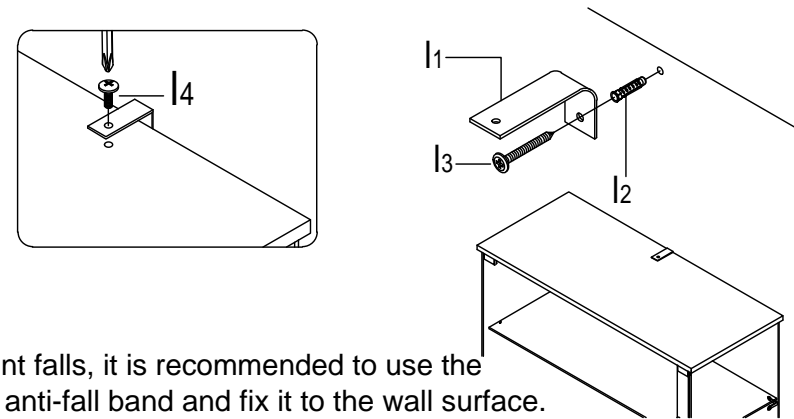

To prevent falls, it is recommended to use the provided anti-fall band and fix it to the wall surface. Periodically check the bolts and screws for looseness and re-tighten them if they are.

Mark 10mm below the height of the product, install the screw receiver [L2] on the wall, Secure the fall prevention band [L1] with screws [L3]. Place the product on the wall while pulling the attached anti-fall band [L1] upward and fix it to the top plate with screws [L4].

## TWO PEOPLE REQUIRED FOR ASSEMBLY

29

Check all screws for looseness and you're done.

※To balance and tilt the opening and closing of the glass (front screen), tighten the screws on the door support fitting (upper and lower parts), Please adjust the insertion position and adjust it.

※When moving products, please be sure to do so with two or more people.

Also, to prevent damage, please take the displayed collection out of the case and remove the glass shelf board before moving it.

Use remote control for on/off control, dimming and setting operation duration.

