

# Assembly Instructions

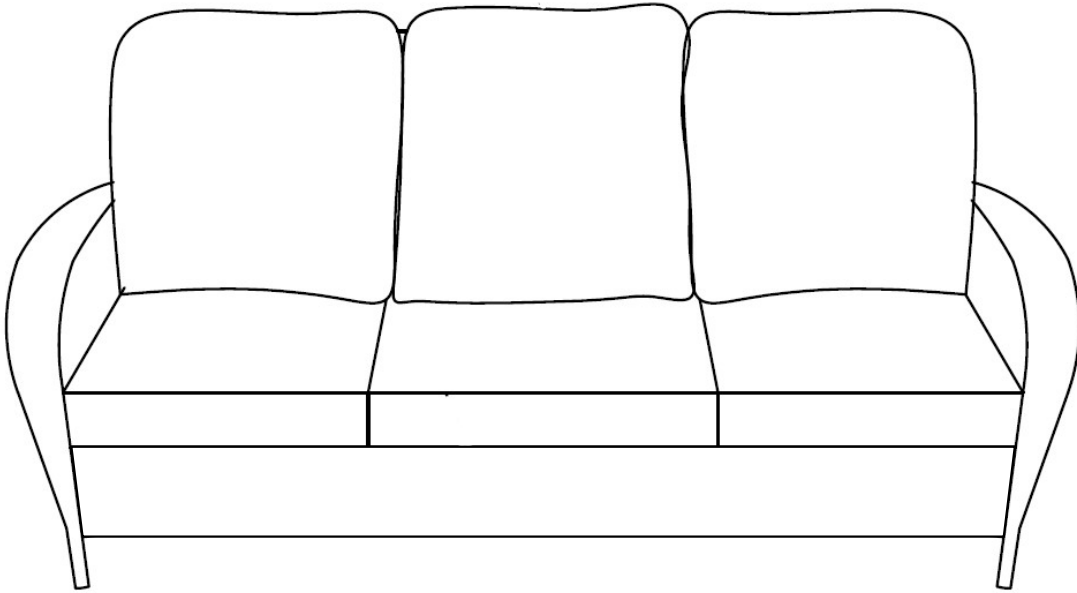

**Assembly  
Video**











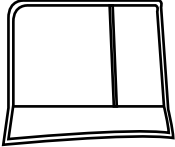

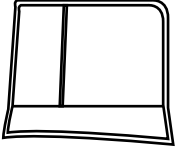

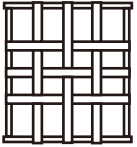
For any missing hardware, damaged parts and other problems.  
WELCOME to email us at: [service@behousewell.com](mailto:service@behousewell.com)

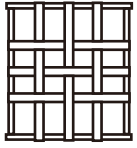
Or call at 1-888-733-8169 Toll free  
Between 9AM and 5PM Eastern time, Monday through Friday

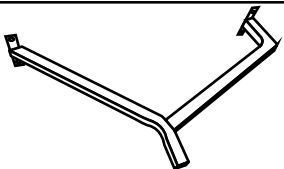
**\*Don't fully tighten all the bolts till the very end!**

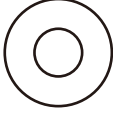
## PRE-ASSEMBLY PREPARATION:

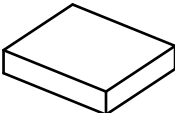
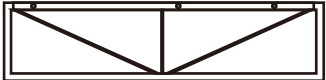
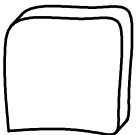
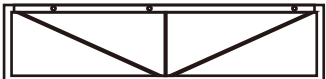
- Please read through the instructions before beginning assembly.
- Clear out the space for assembly and lay out all of the parts based on the Parts List, extra room will allow you to easily determine if all the pieces are present.
- Keep small parts and pieces away from children until fully assembled.

Part no.	Part	QTY	Image	Part no.	Part	QTY	Image
B1	Left Chair Back	1		F	Screws M6*38mm	22	
B2	Right Chair Back	1		F1	Screws M6*15mm	4	
D1	Seat Panel	2		F2	Screws M6*55mm	2	
D2	middle Seat Panel	1		F3	Nuts	2	
C	middle foot	1		F4	little Washers	26	
A1	Left Arm	1		F5	big Washers	4	
A2	Right Arm	1		G	Seat Cushion	3	
E	Left Front skirt	1		H	Back Cushion	3	
E1	Right Front skirt	1		I	Allen Wrench	1	
				I1	Wrench	1	

**Step 1:** Attach back panels B1&B2 with 2pcs bolts F and 2pcs washers F4,using Allen wrench I. Note: Don't fully tighten the bolts.

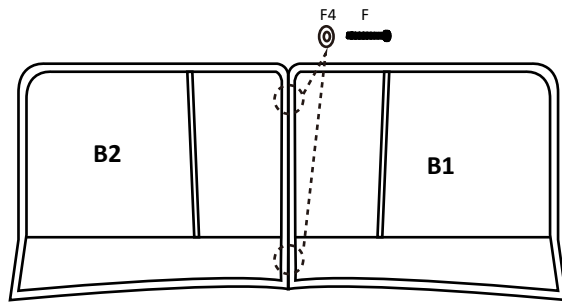

**Step 2:** Attach middle foot C to middle seat D2 with 4pcs bolts F1 and 4pcs washers,using Allen wrench I. Note: Don't fully tighten the bolts.

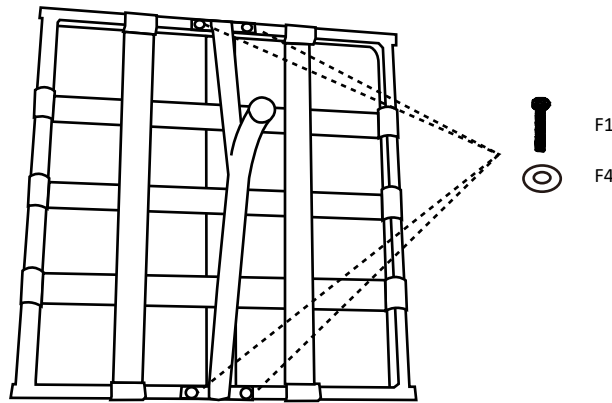

**Step 3:** Attach front panels E&E1 with 2pcs bolts F2 ,4pcs washer F5 and 2pcs nut F3,using Allen wrench I and wrench I1. Note: Don't fully tighten the bolts.

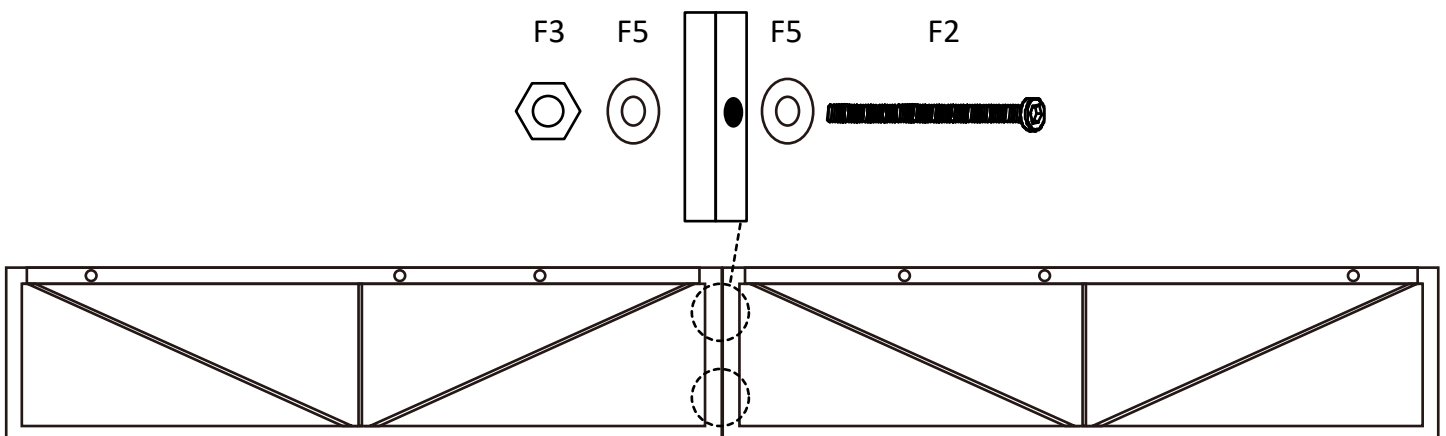

**Step 5:** Attach arms A1&A2 to front panels E1&E2 with 4pcs bolts F and 4pcs washers F4,using Allen wrench I .Note: Don't fully tighten the bolts.

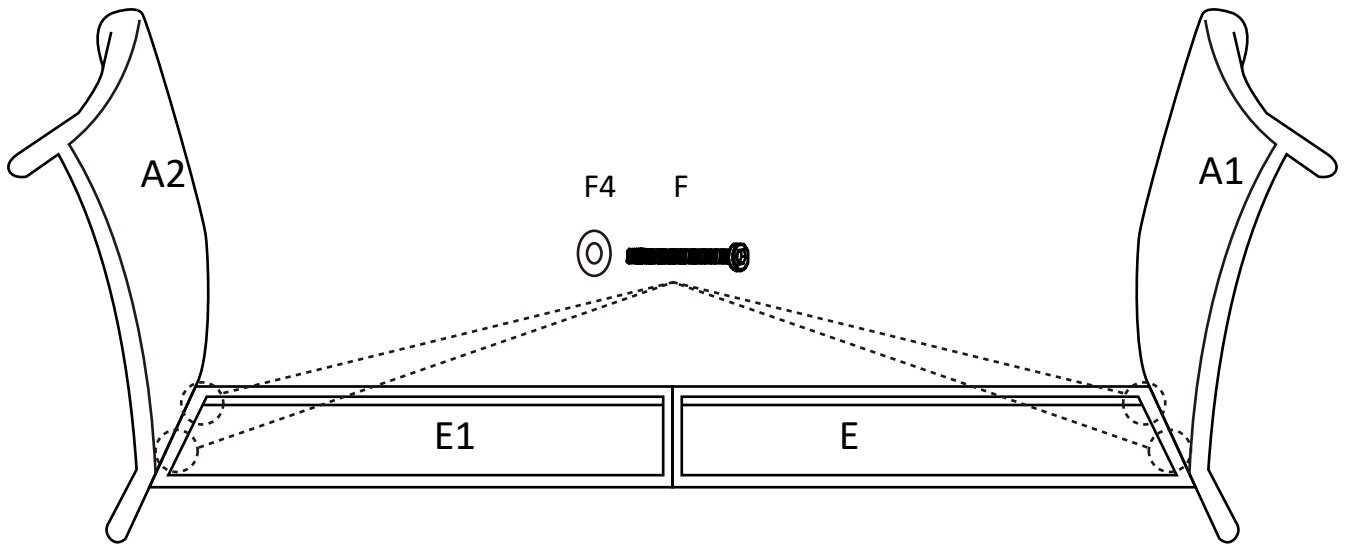

**Step 6:** Attach arms A1&A2 to back panels B1&B2 with 4pcs bolts F and 4pcs washers F4 ,using Allen wrench I1.Note: Don't fully tighten the bolts.

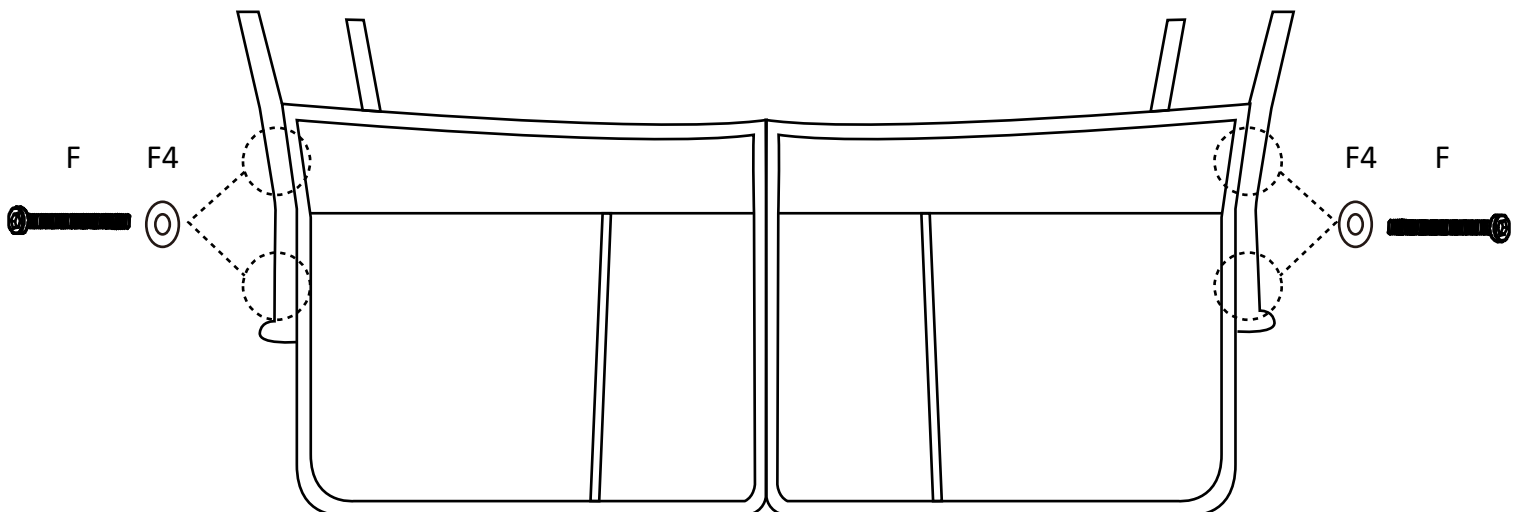

**Step 7:** Firstly attach seat panels to front panels with 6pcs bolts F and 6pcs washers F4, secondly attach seat panels to back panels with 6pcs bolts F and 6pcs washers F4,using Allen wrench I1. Note: Please tighten all the bolts.

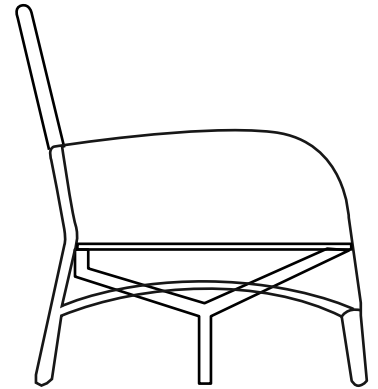
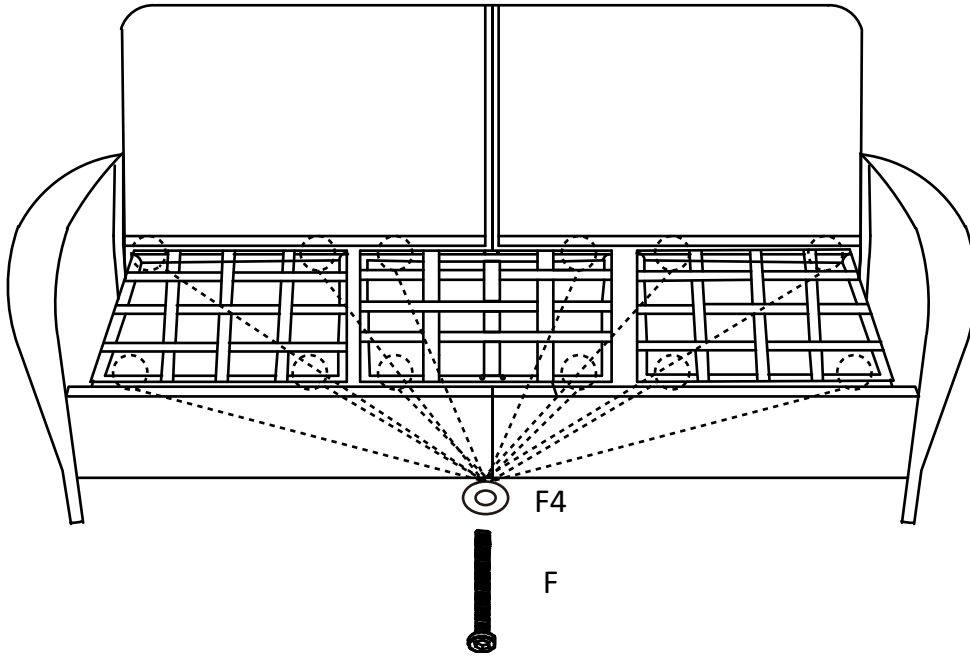

Remark: When attach the middle seat panel , please pay attention to the direction of the middle foot as the picture.

**Step 8:** Put the seat cushion and back cushion onto the seat .Assembly is now complete and the product is ready for use.

