

# Assembly Instruction

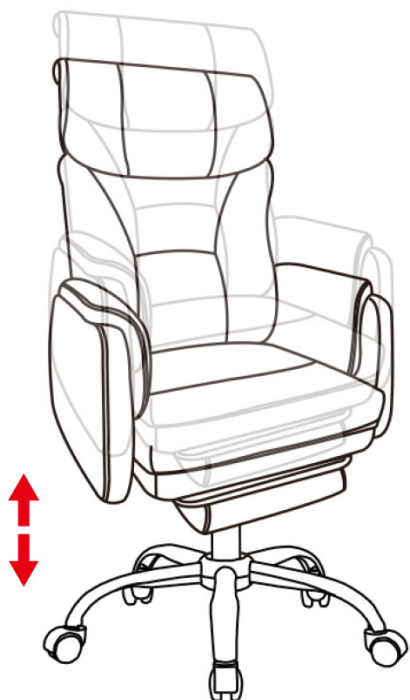

# Instruction for Use



Up and Down Adjustment

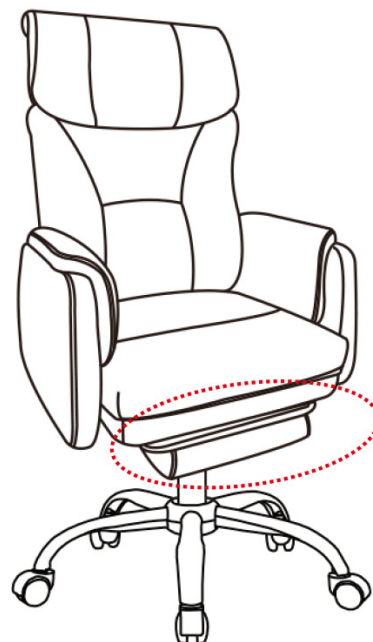

Retractable Footrest











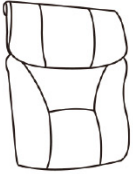

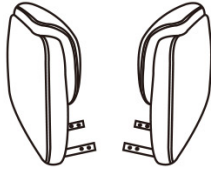
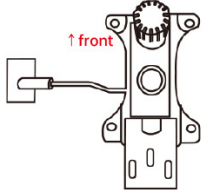

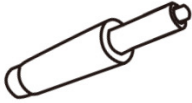
3-Gear Recline Backrest

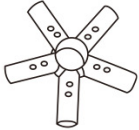
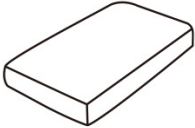

Extendable Cushion Width

# Assembly Parts List

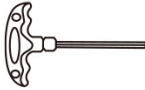
(1) Backrest 	(2) Seat Cushion 	(3) 2 Armrests 	(4) Base Plate 
(5) 5 Split Base Tubes 	(6) Air Rod 	(7) 5 Castors 	(8) Central Base Tube 
(9) Footrest 	(10) Keel 	(11) 14 Screws (M6*20mm) 	(12) 8 Screws (M6*25mm) 
(13) 6 Screws (M6*30mm) 	(14) 3 Screws (M8*20mm) 	(15) Hexagon Wrench 	

## Notice

- Firmly secure all parts before use.
- Reconfirm that all parts are secure every 90 days.
- Do not use or store this item or its parts in the proximity of open flame or flammable/combustible chemicals.
- Do not expose this product to water.
- Do not stand on the chair.
- Do not let small children or pets near during assembly.
- Do not use this item in a way inconsistent with the manufacturer's instructions as this could void the product warranty.

# Assembly Instruction

Please assemble in a wide and flat place.

## Step 1:

Take out Split Base Tube (5) and Central Base Tube (8). Insert Split Base Tube (5) into Central Base Tube (8) as shown. You can see there are screw holes. Align with the holes, tighten M6X20mm Screws (11) with Hexagon Wrench (15) to fix 5 Split Base Tubes (5) to Central Base Tube (8). Repeat it ten times.

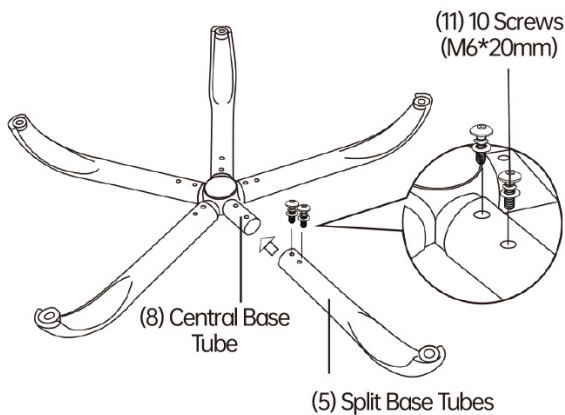

## Step 2:

Take out Castors (7). Insert Castors (7) into part of Step 1 as shown. There are 5 Castors (7) need to be inserted. Take out Air Rod (6). Put Air Rod (6) into the hole of Central Base Tube (8) as shown.

**\* Caution: Confirm Castors (7) must be inserted deeply. Otherwise the castors could easily fall out and the chair could fall down.**

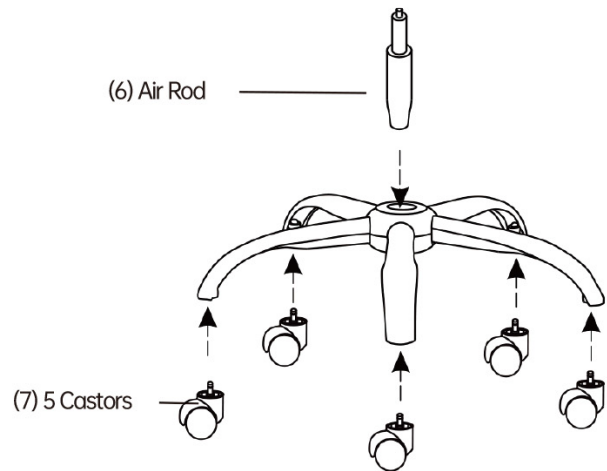

## Step 3:

Attach the left and right Armrests (3) to the Seat Cushion (2) with 8 M6\*25mm Screws (12) and Hexagon Wrench (15).

**\* Caution: Tighten the screws to 50% first and then tighten them when all the screws are in place. The zipper faces toward the backrest side, opposite to the "Front" marking. Armrests are marked L (Left) and R (Right). Please ensure correct installation.**

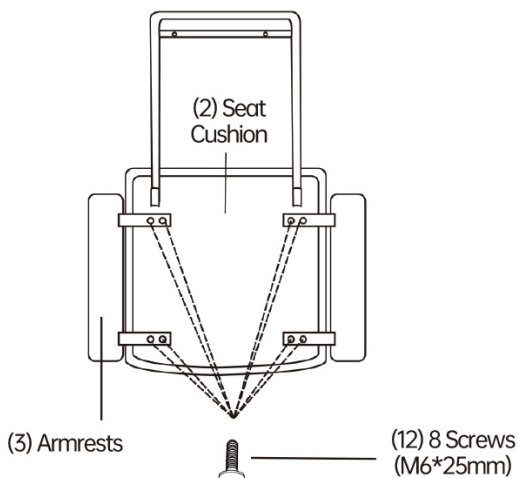

## Step 4:

Attach Footrest (9) to Seat Cushion (2) with 2 M6\*30mm Screws (13) and Hexagon Wrench (15).

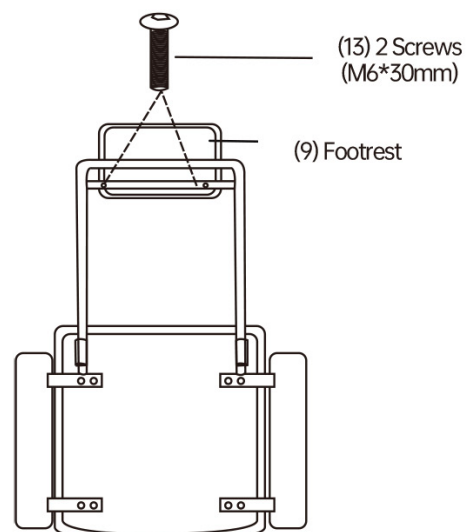

## Step 5:

Fix Base Plate (4) to the bottom of Seat Cushion (2). Tighten the 4 M6\*20mm Screws (11) with Hexagon Wrench (15) firmly.

\* Caution: There is a FRONT sticker on the front of Seat Cushion (2). Tighten the screws to 50% first and then tighten them when all the screws are in place.

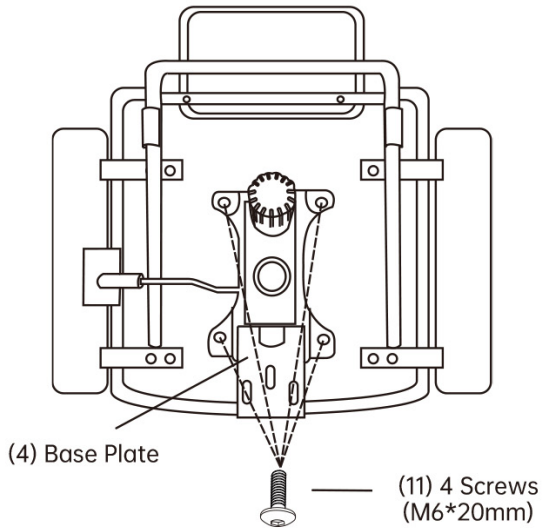

## Step 6:

Fix Keel (10) to the bottom of Seat Cushion (2). Tighten the 3 M8\*20mm Screws (14) with Hexagon Wrench (15) firmly.

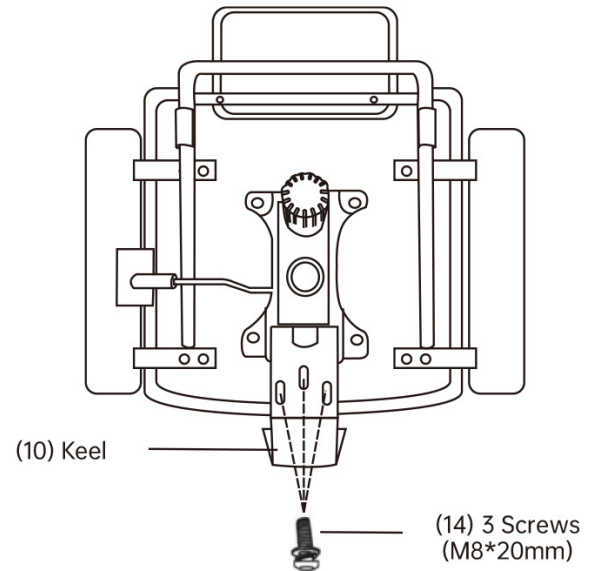

## Step 7:

Fix the Keel (10) to the back of the Backrest (1). Tighten the 4 M6\*30mm Screws (13) with Hexagon Wrench (15) firmly.

\*Caution: It is better for two people to work together to secure the Backrest (1) to the Seat Cushion (2).

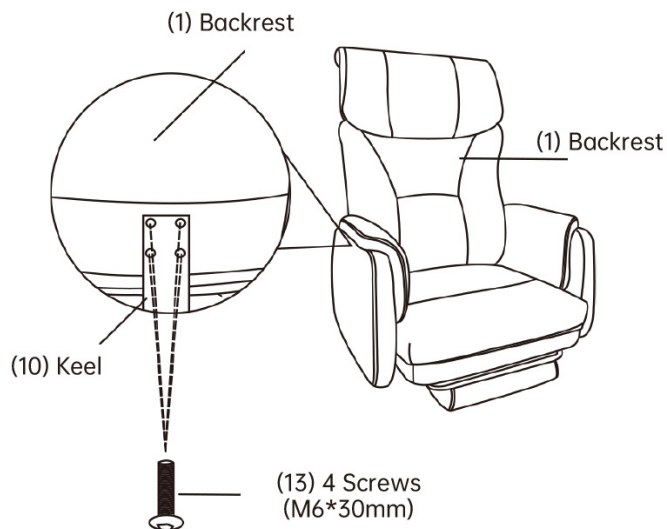

## Step 8:

Pick up the Step 2's Air Rod (6) and Central Base Tube (8). Insert the Air Rod (6) into Step 7's Base Plate (4). There's a hole in the middle of Base Plate (4). Press the Seat Cushion (2) from top to bottom, use your whole body's strength to insert it firmly, the assembly is complete now.

