

ASSEMBLY INSTRUCTION
INSTRUCTIONS DE MONTAGE

DAYBED WITH CUSHIONS
CANAPÉ-LIT DE JARDIN

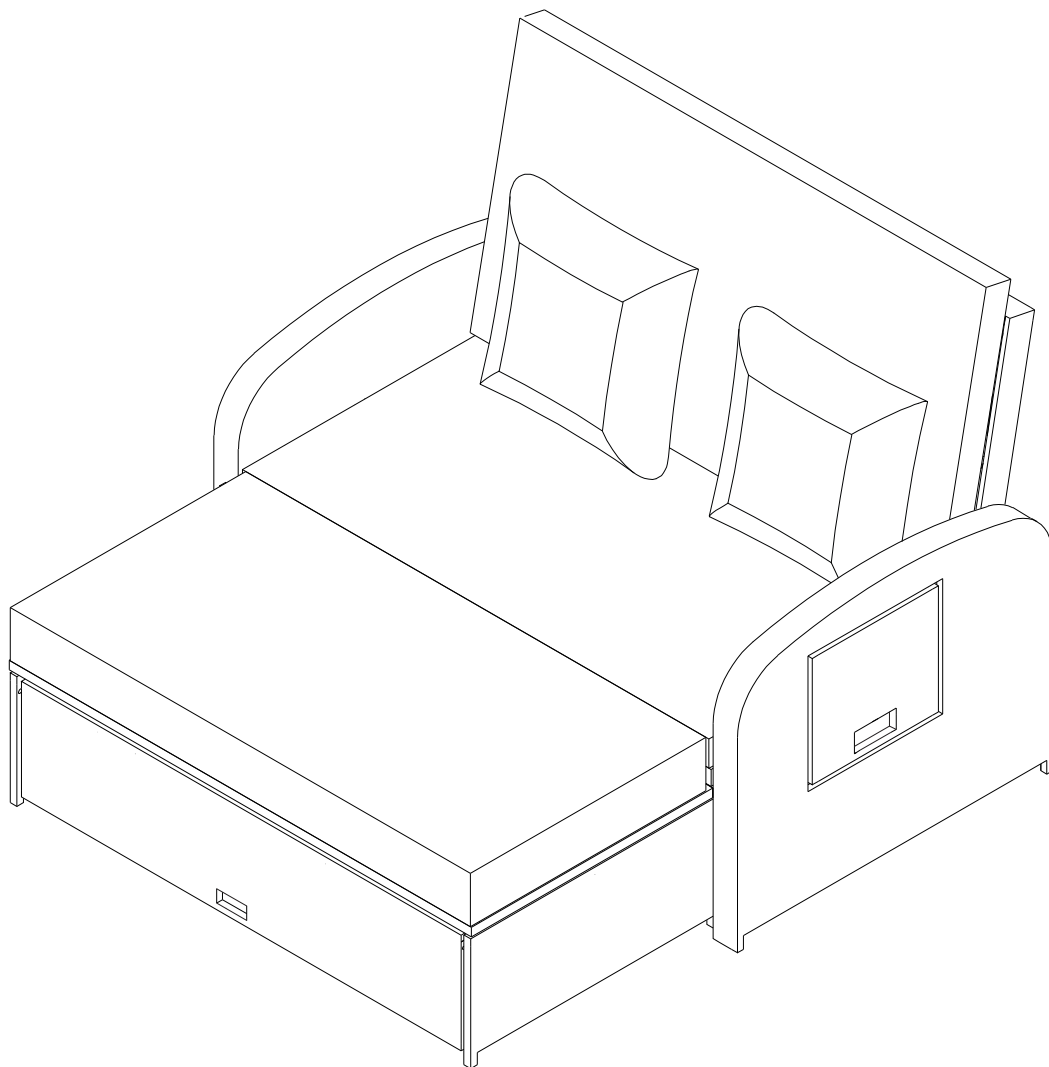

NOTE: 50% TIGHTEN BEFORE FIXING ALL BOLTS

REMARQUE : SERRER À 50 % AVANT DE FIXER TOUS LES BOULONS

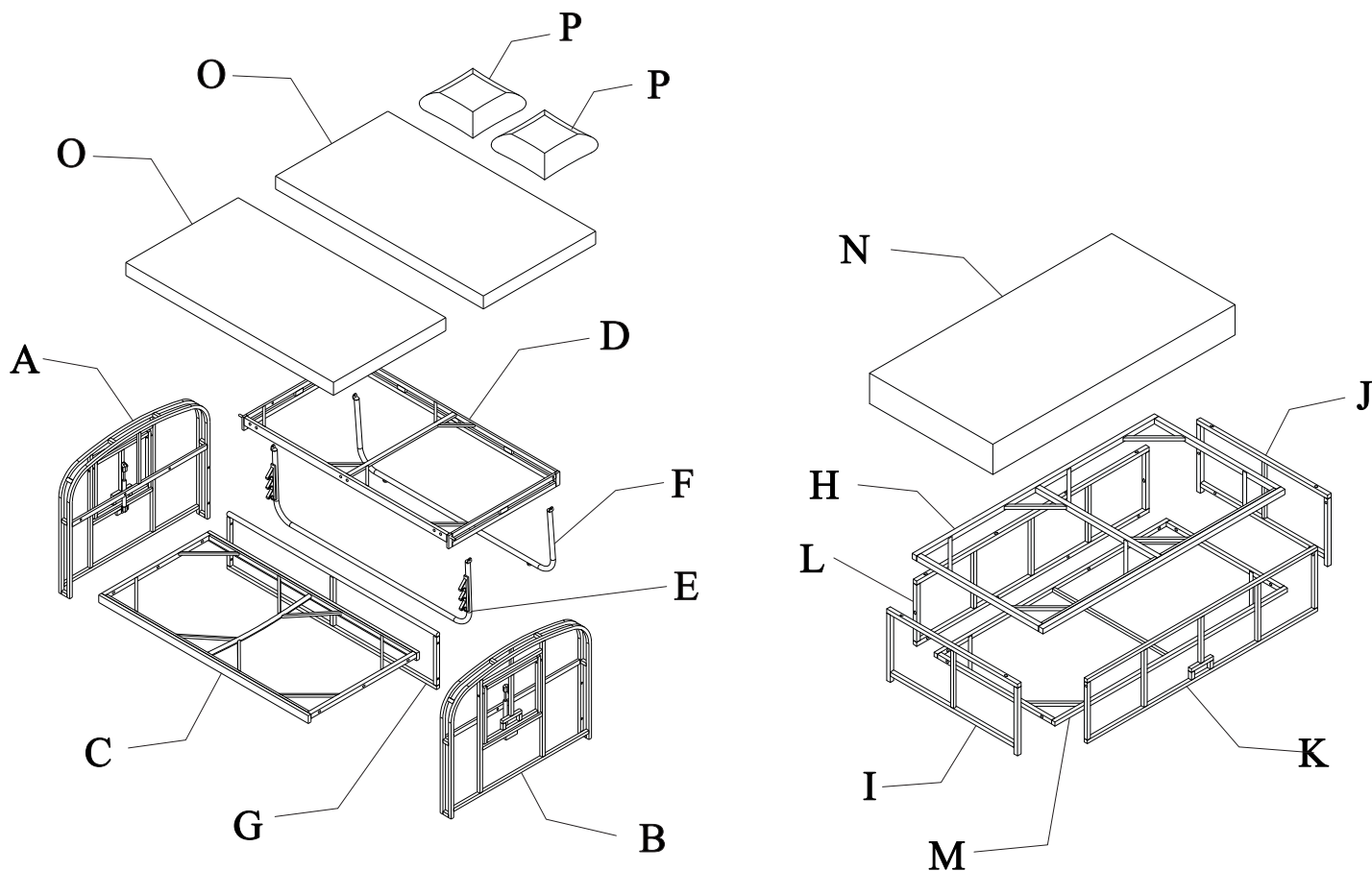

Notice:

1. **50% Tighten before fixing all screws, Allen wrench is recommended instead of an electric drill.**
2. **Place the item on a flat ground to adjust and make sure it remains stable**
3. **Tighten up all screws with tools gradually.**
4. **If the screws are not aligned with holes during assembly, please loosen all the other screws to 50% and continue the assembly process.**
5. **If the item is not stable, please loosen all the screws, adjust it on a flat ground and tighten up all screws again.**
6. **Note : If one or some screws are fully tightened during assembly, chances are the others will not be aligned with holes. In addition, all the holes are designed to be**

Avis :

1. **Serrez à 50% avant de fixer toutes les vis, une clé Allen est recommandée à la place d'une perceuse électrique.**
2. **Placez l'objet sur une surface plane pour ajuster et assurer sa stabilité.**
3. **Serrez progressivement toutes les vis avec des outils.**
4. **Si les vis ne sont pas alignées avec les trous pendant l'assemblage, veuillez desserrer toutes les autres vis à 50% et poursuivre l'assemblage.**
5. **Si l'objet n'est pas stable, veuillez desserrer toutes les vis, ajuster sur une surface plane et resserrer toutes les vis.**
6. **Remarque : Si une ou plusieurs vis sont complètement serrées pendant l'assemblage, il est probable que les autres ne seront pas alignées avec les trous. En outre, tous les trous sont conçus pour être relativement plus grands afin de fournir plus d'espace pour l'ajustement des vis.**

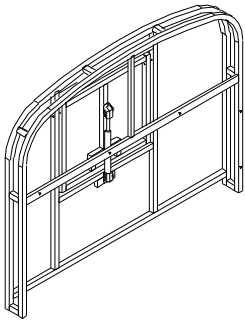
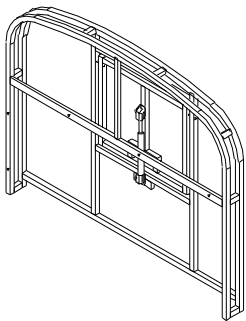
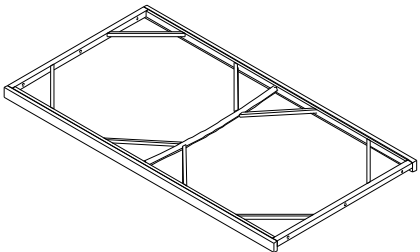
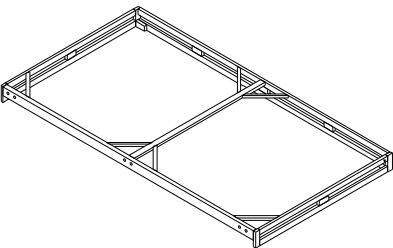
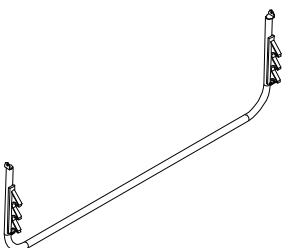
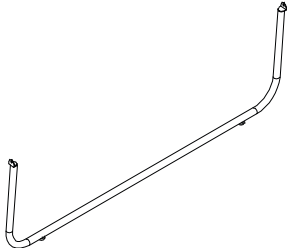
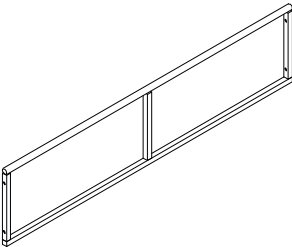
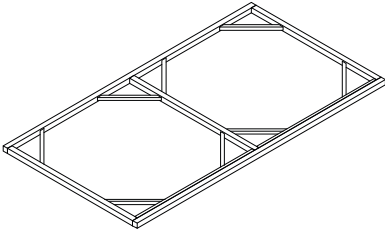
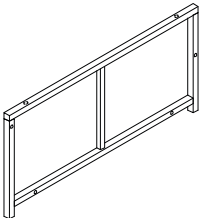
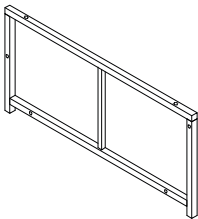
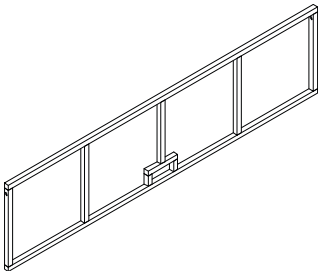
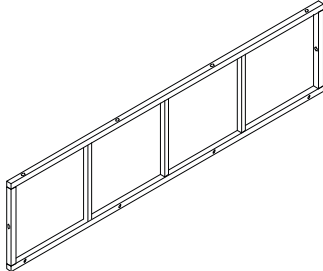

Part List / Liste des pièces

<p>A</p>  <p>Arm Right Frame (1 pc) / Bras Droit Cadre (1 pc)</p>	<p>B</p>  <p>Arm Left Frame (1 pc) / Bras Cadre Gauche (1 pc)</p>	<p>C</p>  <p>Bench Seat Frame (1 pc) / Cadre de banquette (1 pc)</p>
<p>D</p>  <p>Bench Back Frame (1 pc) / Cadre de dossier de banc (1 pc)</p>	<p>E</p>  <p>Hip Back Frame (1 pc) / Cadre arrière de hanche (1 pc)</p>	<p>F</p>  <p>Hip Back Frame (1 pc) / Cadre arrière de hanche (1 pc)</p>
<p>G</p>  <p>Bench Back Side Frame (1 pc) / Cadre latéral arrière du banc (1 pc)</p>	<p>H</p>  <p>Stool Seat Frame (1 pc) / Cadre de siège de tabouret (1 pc)</p>	<p>I</p>  <p>Leg Right Stool (1 pc) / Tabouret droit (1 pc)</p>
<p>J</p>  <p>Leg Left Stool (1 pc) / Tabouret à jambe gauche (1 pc)</p>	<p>K</p>  <p>Stool Front Side Frame (1 pc) / Cadre latéral avant du tabouret (1 pc)</p>	<p>L</p>  <p>Stool Back Side Frame (1 pc) / Cadre latéral arrière du tabouret (1 pc)</p>

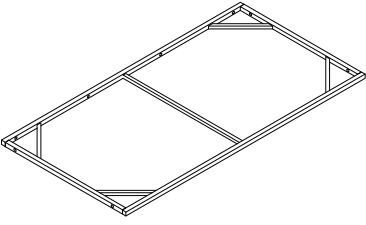
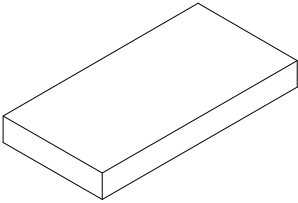
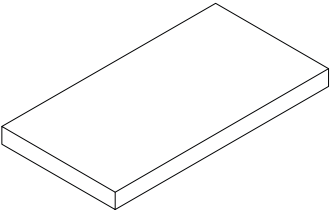
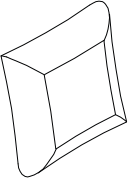
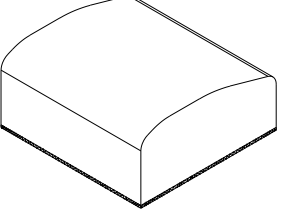
Part List / Liste des pièces

<p>M</p>  <p>Stool Shelf Frame (1 pc) / Cadre d'étagère de tabouret (1 pc)</p>	<p>N</p>  <p>Stool Seat Cushion (1 pc) / Coussin de siège de tabouret (1 pc)</p>	<p>O</p>  <p>Bench Seat Cushion & Back Cushion (2 pcs) / Coussin de banquette & Coussin de dossier (2 pcs)</p>
<p>P</p>  <p>Back Pillow (2 pcs) / Oreiller de dos (2 pcs)</p>	<p>Q</p>  <p>Cover cloth (1 pc) / Tissu de couverture (1 pc)</p>	

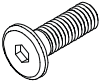
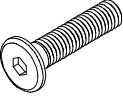
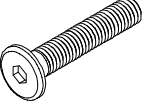
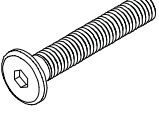
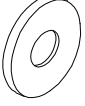
Hardware List / Liste du matériel

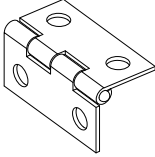
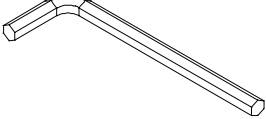
<p>1</p>  <p>M6x15mm Bolt (12pcs + extra 2 pcs) / Boulon (12pcs + supplémentaire 2 pcs)</p>	<p>2</p>  <p>M6x30mm Bolt (4pcs + extra 1 pc) / Boulon (4pcs + supplémentaire 1 pc)</p>	<p>3</p>  <p>M6x35mm Bolt (24pcs + extra 2 pcs) / Boulon (24pcs + supplémentaire 2 pcs)</p>
<p>4</p>  <p>M6x40mm Bolt (6pcs + extra 1 pc) / Boulon (6pcs + supplémentaire 1 pc)</p>	<p>5</p>  <p>M6x16x1mm Washers (34pcs + extra 3pcs) Rondelles (34pcs + supplémentaire 3pcs)</p>	<p>6</p>  <p>M6x20x5mm Plastic Washers (2 pcs + extra 1pc) / Rondelles en plastique (2 pcs + supplémentaire 1pc)</p>
<p>7</p>  <p>M6x20x15mm Plastic Washers (4 pcs + extra 1pc) / Rondelles en plastique (4 pcs + supplémentaire 1pc)</p>	<p>8</p>  <p>Hinger (3 pcs) / Charnière (3 pcs)</p>	<p>9</p>  <p>M4*60 Allen Key (2pcs) / Clé Allen (2pcs)</p>

CARTON CONTENT/CONTENU DU CARTON

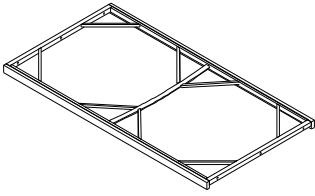

C x 1

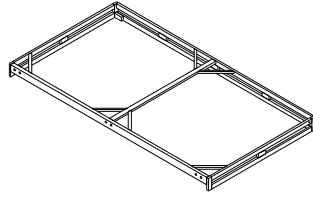

D x 1

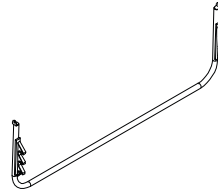

E x 1

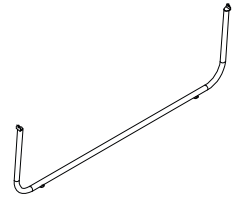

F x 1

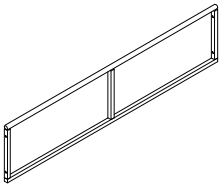

G x 1

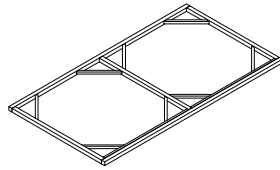

H x 1

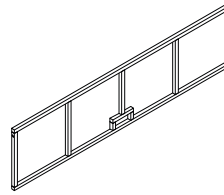

K x 1

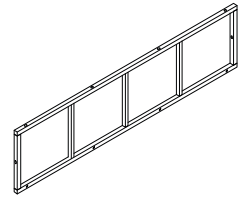

L x 1

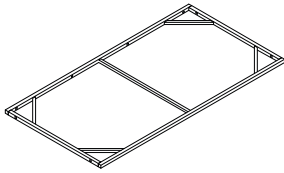

M x 1

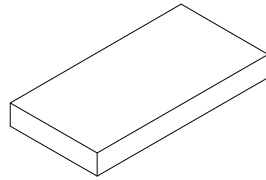

N x 1

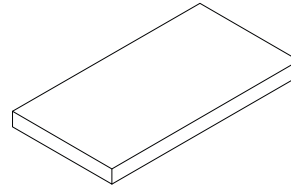

O x 2

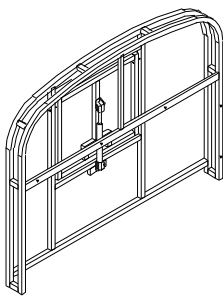

A x 1

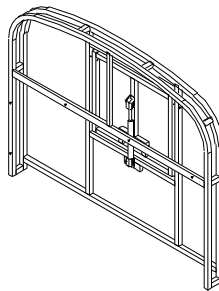

B x 1

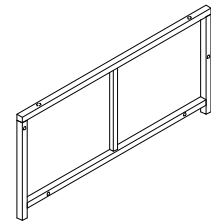

I x 1

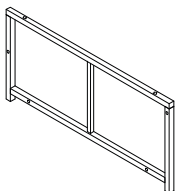

J x 1

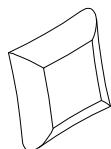

P x 2

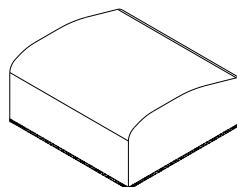

Q x 1

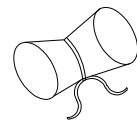

HARDWARE

STEP (ÉTAPE) 1

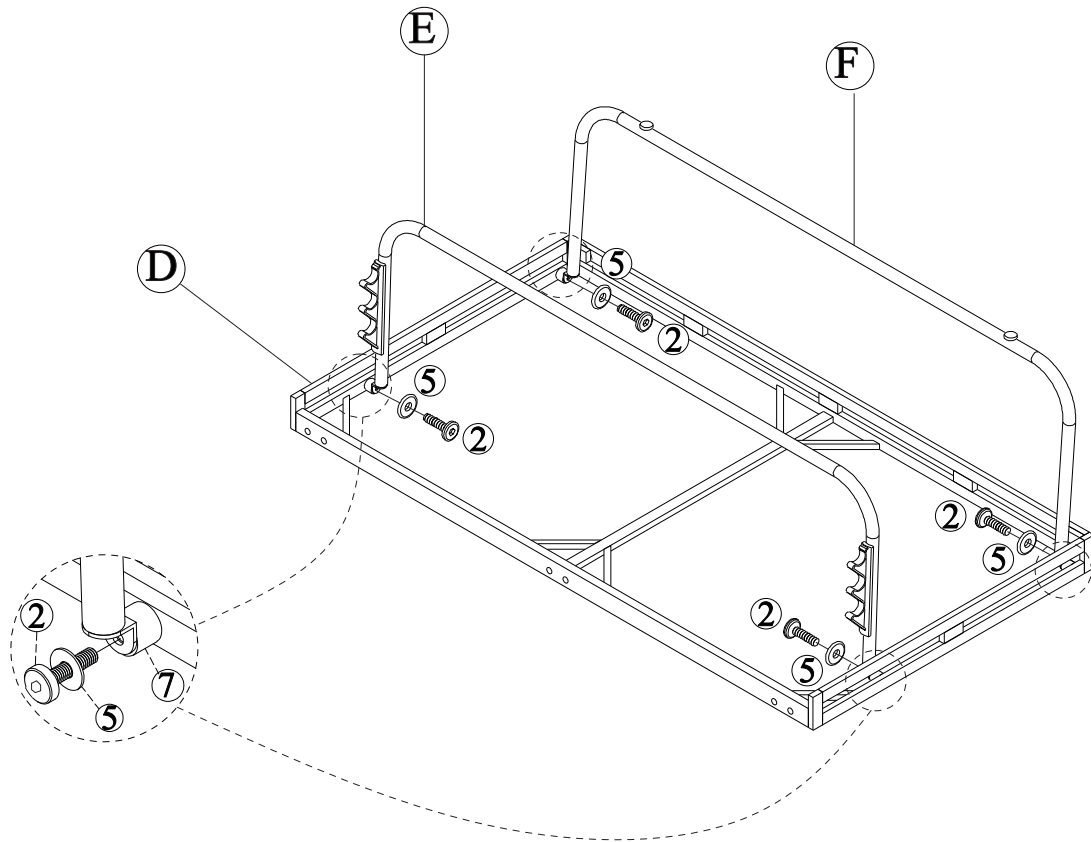

D*1 E*1 F*1 ②*4 ⑤*4 ⑦*4

STEP (ÉTAPE) 2

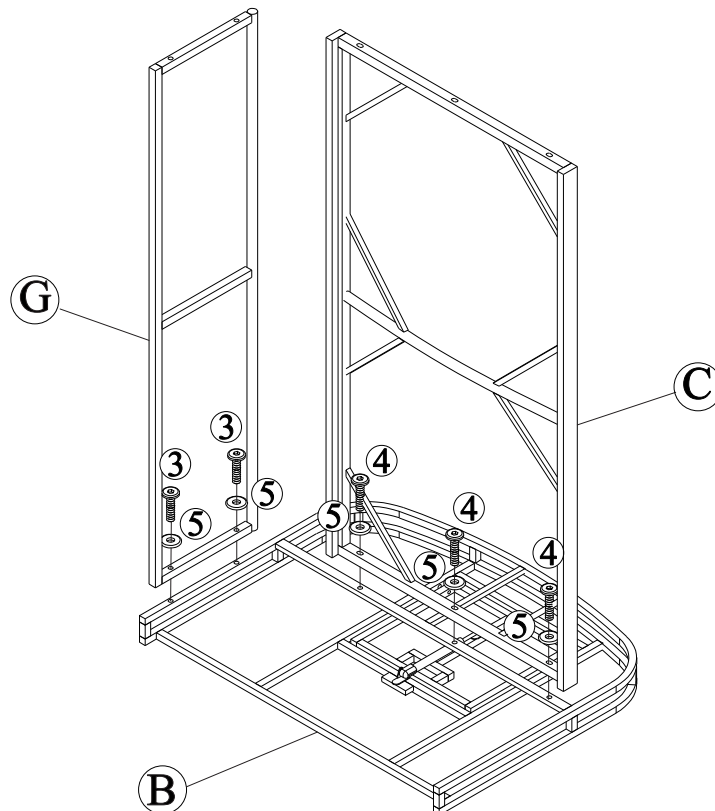

B*1 C*1 G*2 ③*2 ④*3 ⑤*5

STEP (ÉTAPE) 3

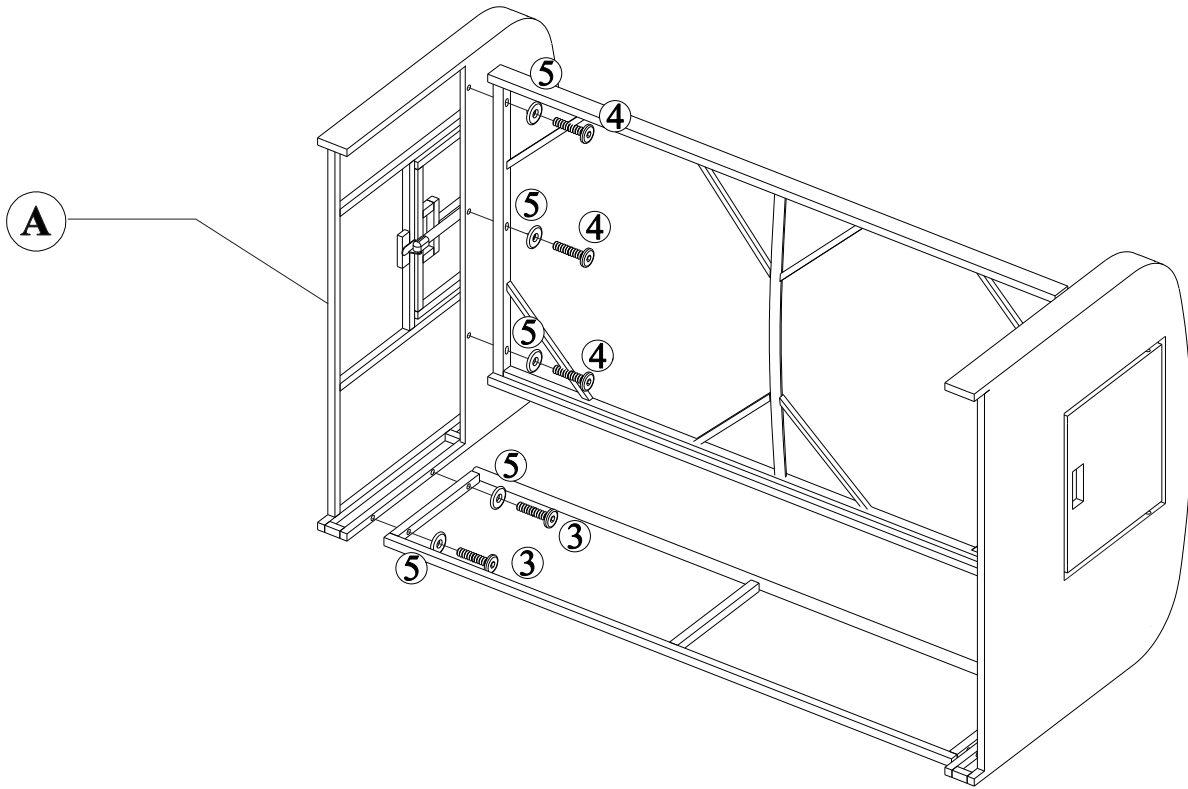

A*1 ③*2 ④*3 ⑤*5

STEP (ÉTAPE) 4

STEP 1 / ÉTAPE 1

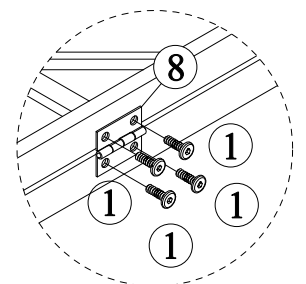
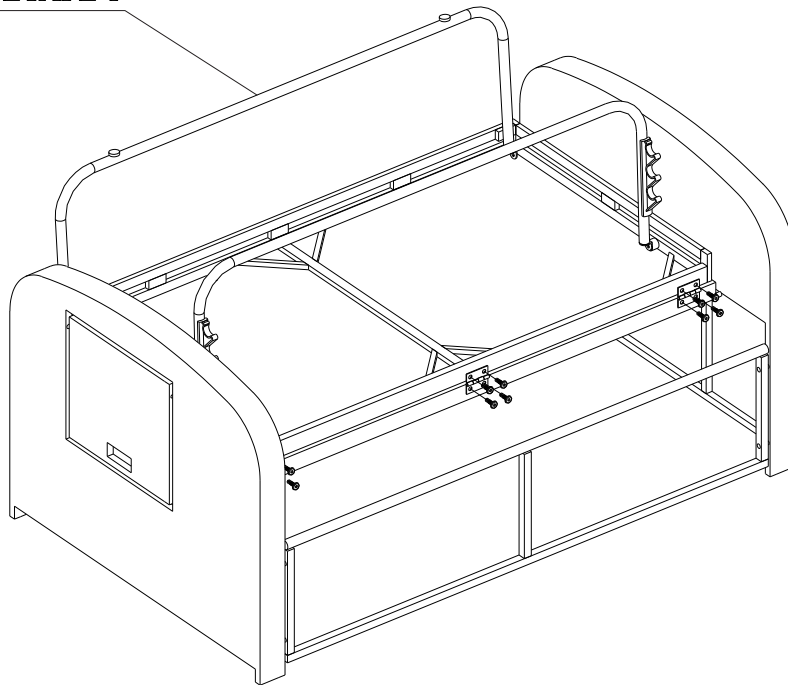

①*12 ⑧*3

STEP (ÉTAPE) 5

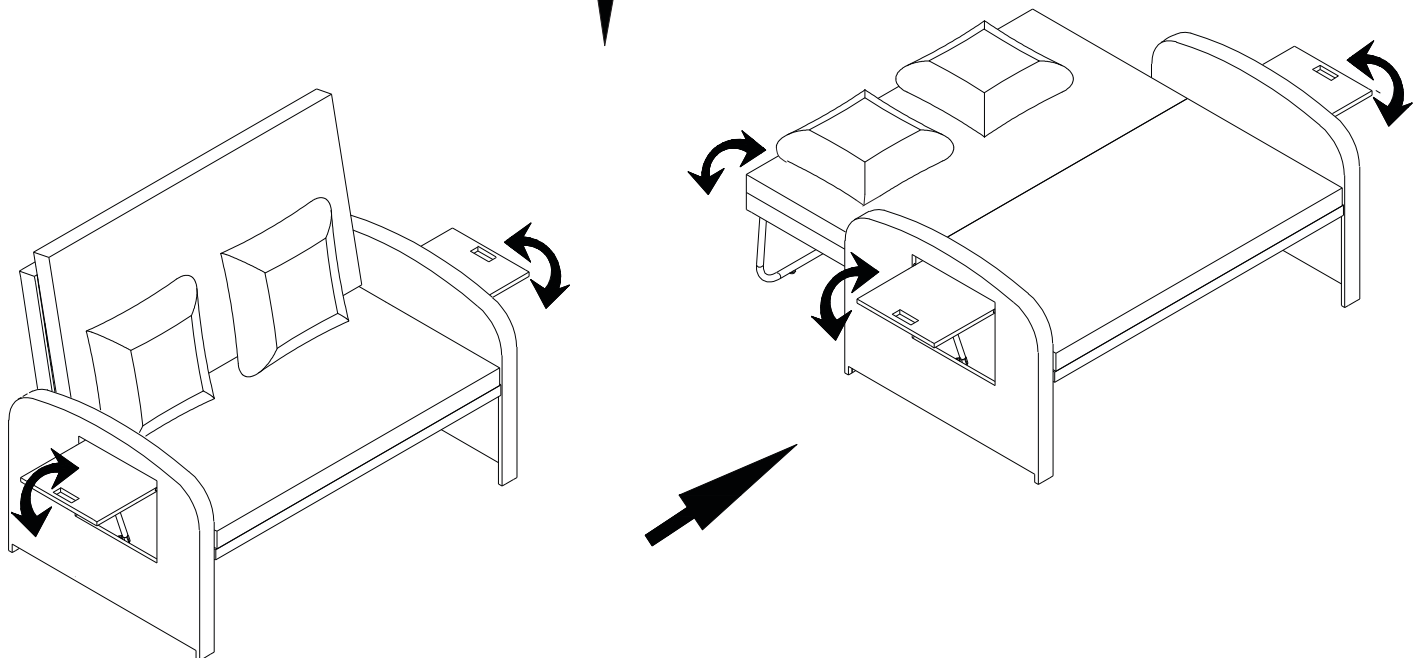
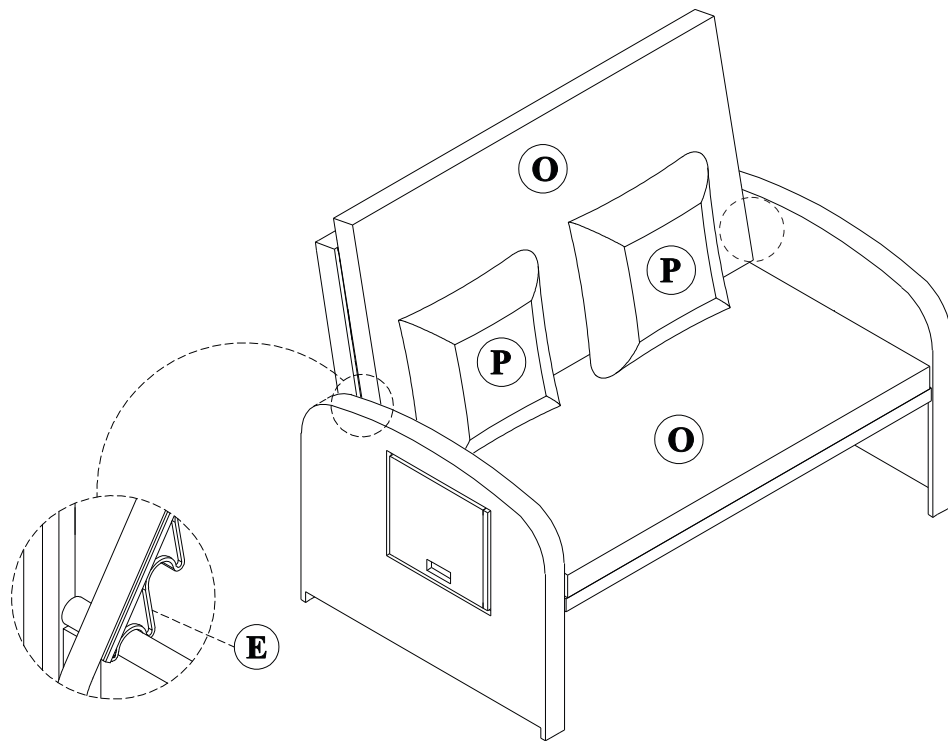

O*2 P*2

STEP (ÉTAPE) 6

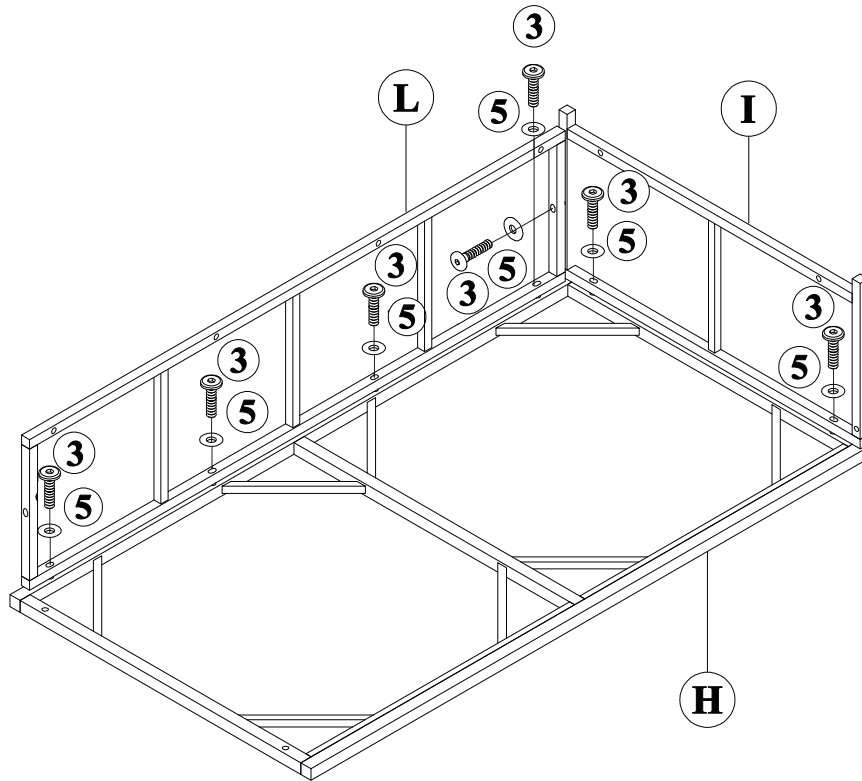

L*1 H*1 I*1 ③*7 ⑤*7

STEP (ÉTAPE) 7

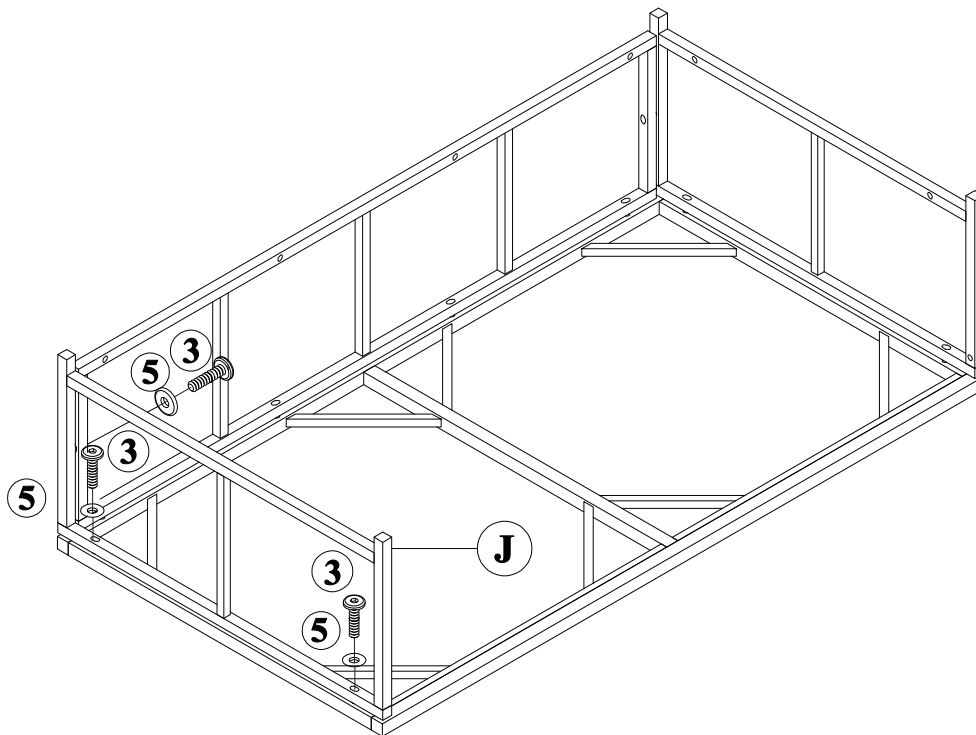

J*1 ③*3 ⑤*3

STEP (ÉTAPE) 8

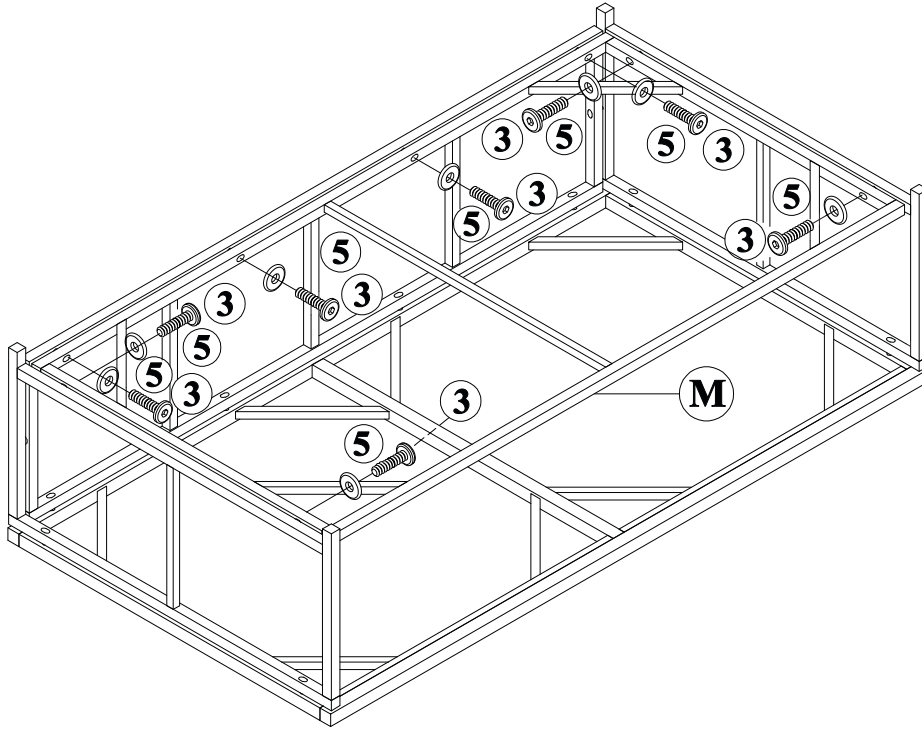

M*1 (3)*8 (5)*8

STEP (ÉTAPE) 9

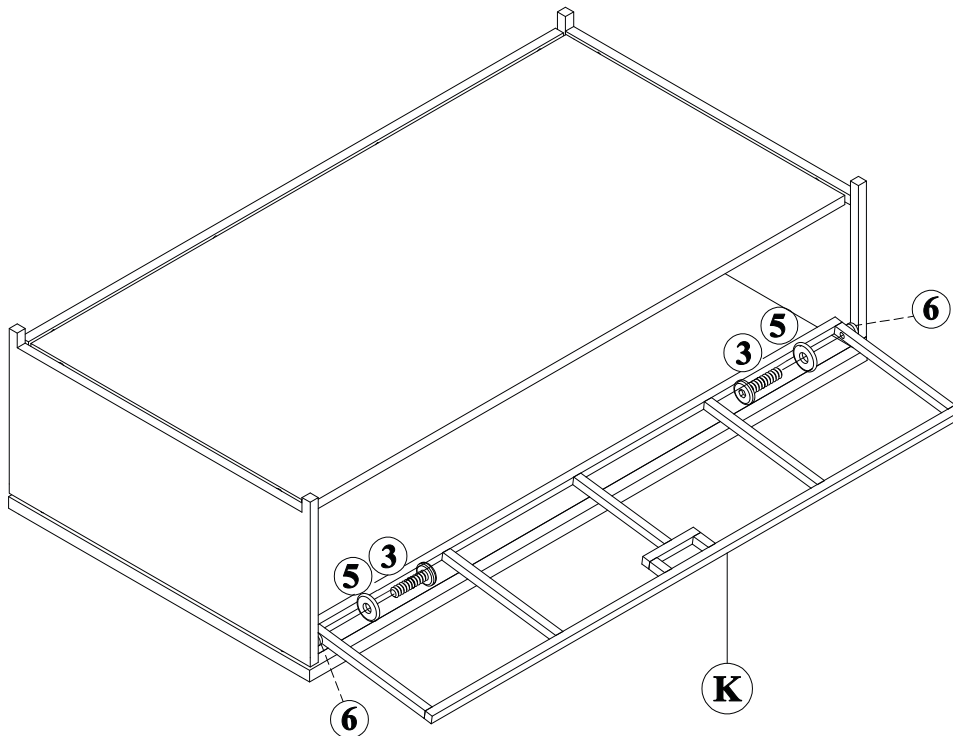

K*1 (3)*2 (5)*2 (6)*2

STEP (ÉTAPE) 10

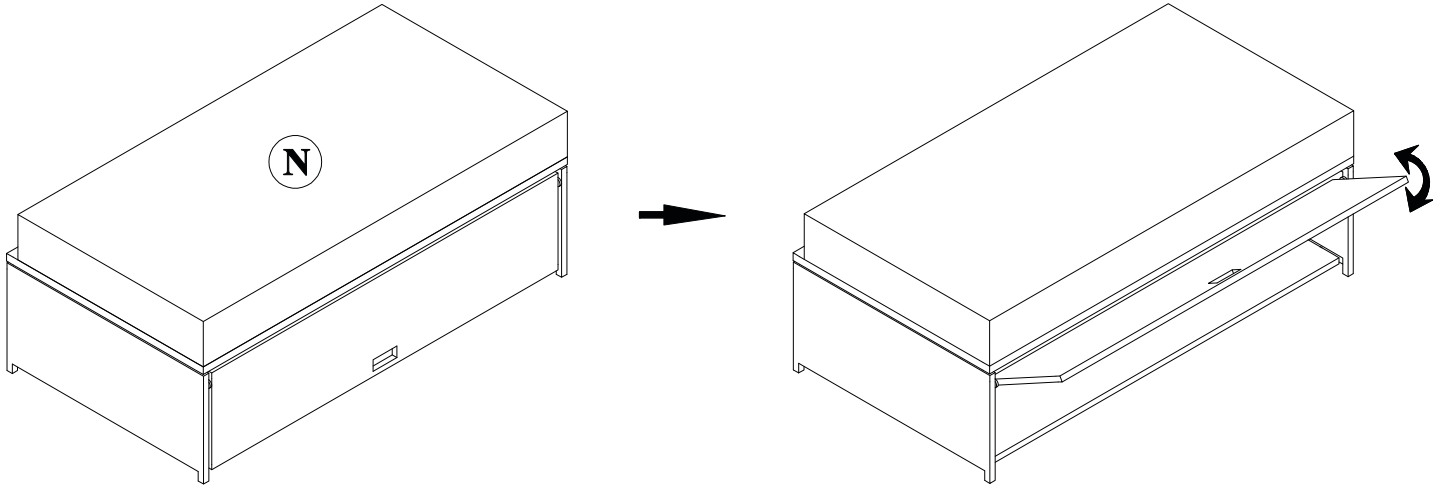

N*1

Take back frame down lowest and cover the product with Cover cloth (Q) when not in use.
/ Retirez le cadre le plus bas et couvrez le produit avec un tissu de couverture (Q) lorsqu'il n'est pas utilisé.

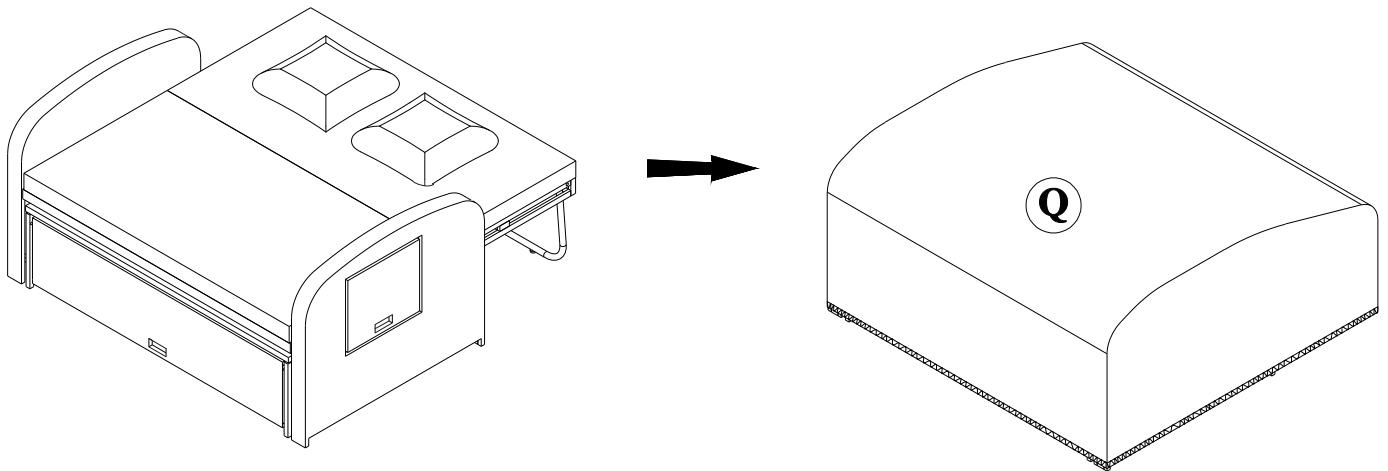

Q*1

Combination and Arrangement
/ Combinaison et arrangement

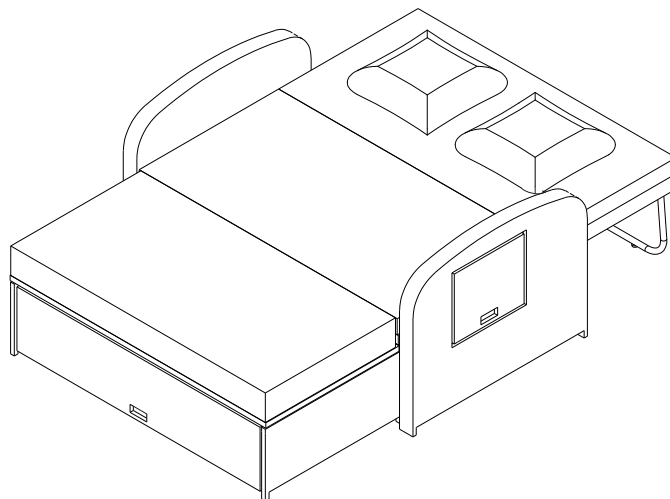
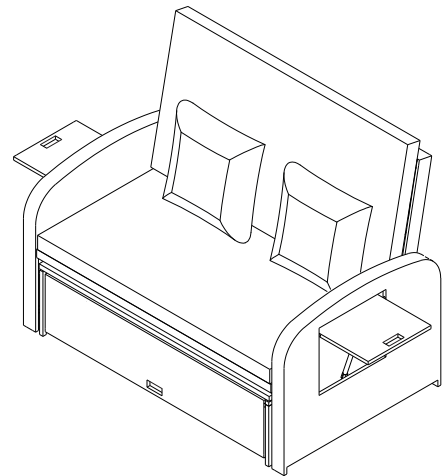
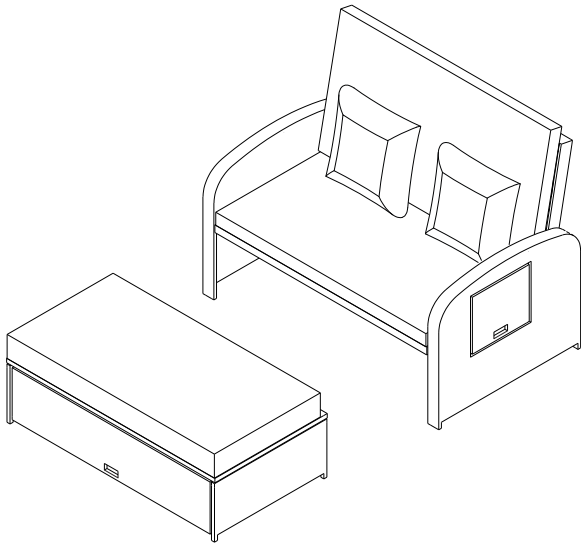
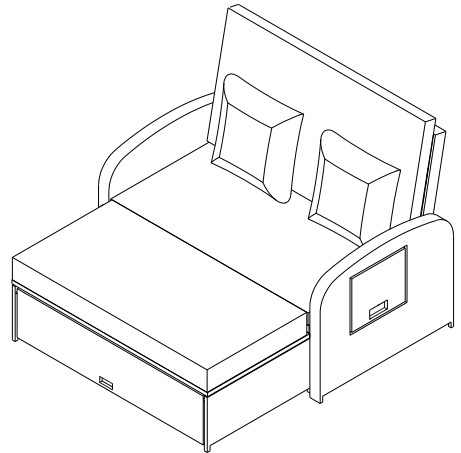
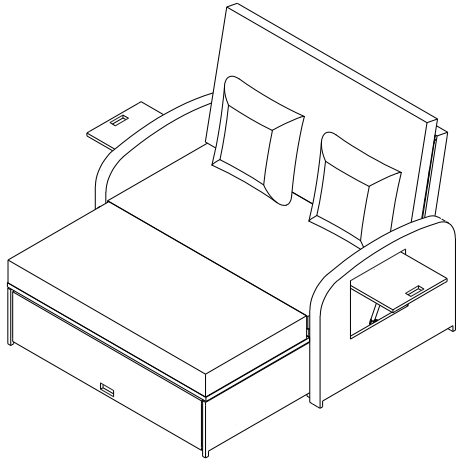

FINISH / FINITION