

BIG AND TALL LADDER BACK BARSTOOL
TABOURET DE BAR ÉLEVÉ AU DOSSIER À TRAVERSESES
TABURETE DE BAR ALTO CON RESPALDO CON TRAVESAÑOS

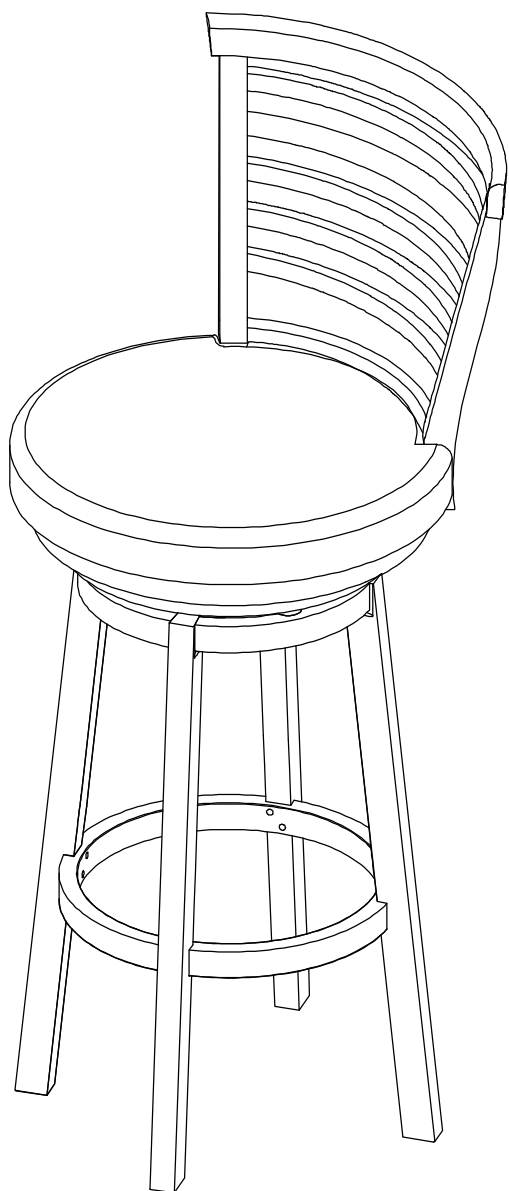

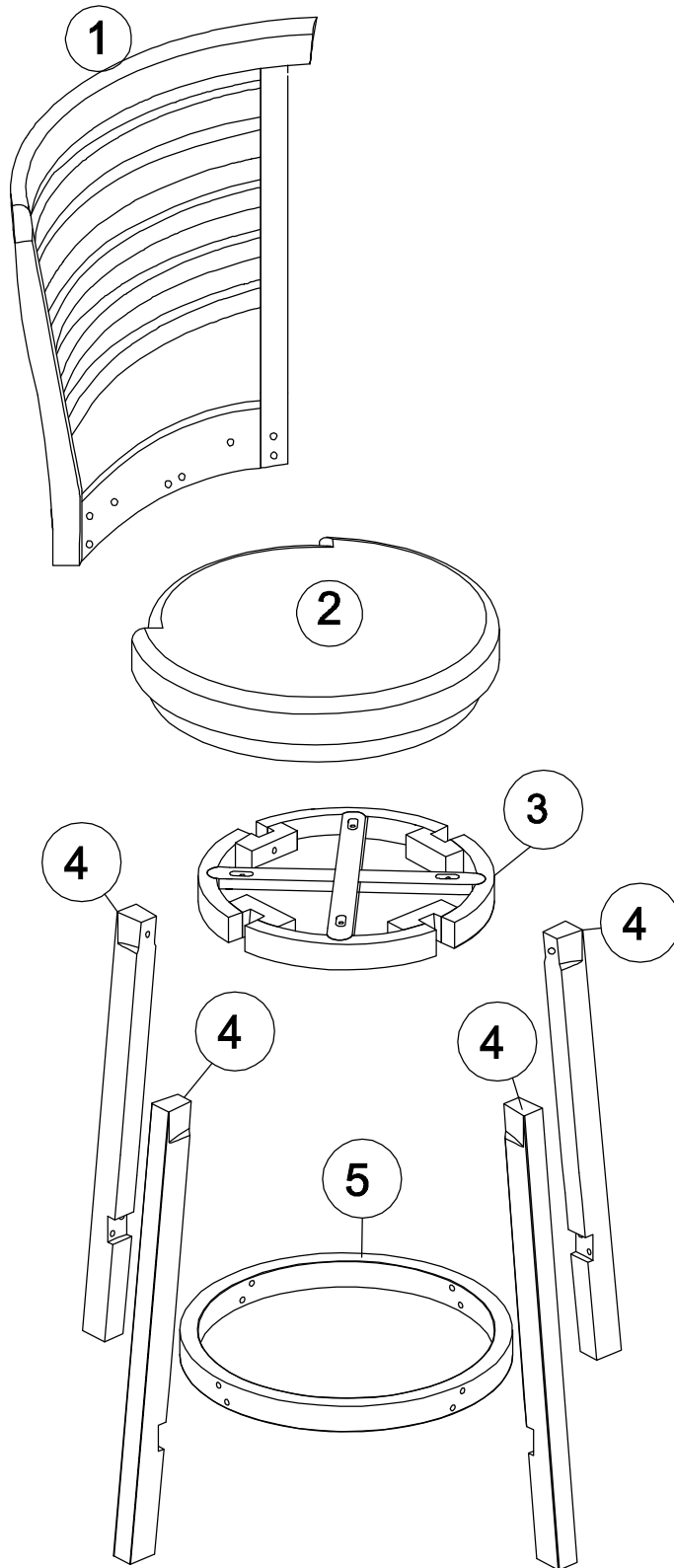



H1 Bolt Ø 1/4"x1-3/16"
(8 pcs)

Boulon Ø 1/4pox2-1/4po
(8 pièces)

Tornillo Ø 1/4"x2-1/2"
(8 piezas)



H2 Bolt Ø 1/4"x1-3/4"
(10 pcs)

Boulon Ø1/4pox1-3/4po
(10 pièces)

Tornillo Ø1/4"x1-3/4"
(10 piezas)



H3 Bolt Ø1/4"x2-3/16"
(4 pcs)

Boulon Ø1/4pox2-3/16po
(4 pièces)

Tornillo Ø1/4"x2-3/16"
(4 piezas)



H4 Bolt Ø 1/4"x2-3/8"
(4 pcs)

Boulon Ø 1/4pox2-3/8po
(4 pièces)

Tornillo Ø 1/4"x2-3/4"
(4 piezas)

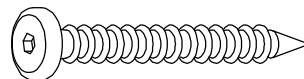

H5 Wood Screw Ø 1/4"x1-3/4"
(2 pcs)

Vis À Tête Plate Ø1/4pox1-3/4po
(2 pièces)

Tornillo De Cabeza Redonda
Ø1/4"x1-3/4"
(2 piezas)



H6 Swivel plate
(1pc)

Plaque pivotante
(1 pièce)

Placa giratoria
(1 pieza)



H7 Spring Washer Ø1/4"
(28 pcs)

Rondelle à ressort Ø1/4po
(28 pièces)

Arandela de resorte Ø1/4"
(28 piezas)



H8 Flat Washer Ø1/4"
(28 pcs)

Rondelle plate Ø1/4po
(28 pièces)

Arandela plana Ø1/4"
(28 piezas)

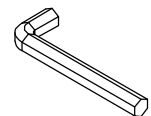

H9 Allen Key 4mm
(1pc)

Clé Allen 4mm
(1 pièce)

Liave Allen 4mm
(1pieza)

STEP 1
ÉTAPE 1
PASO 1

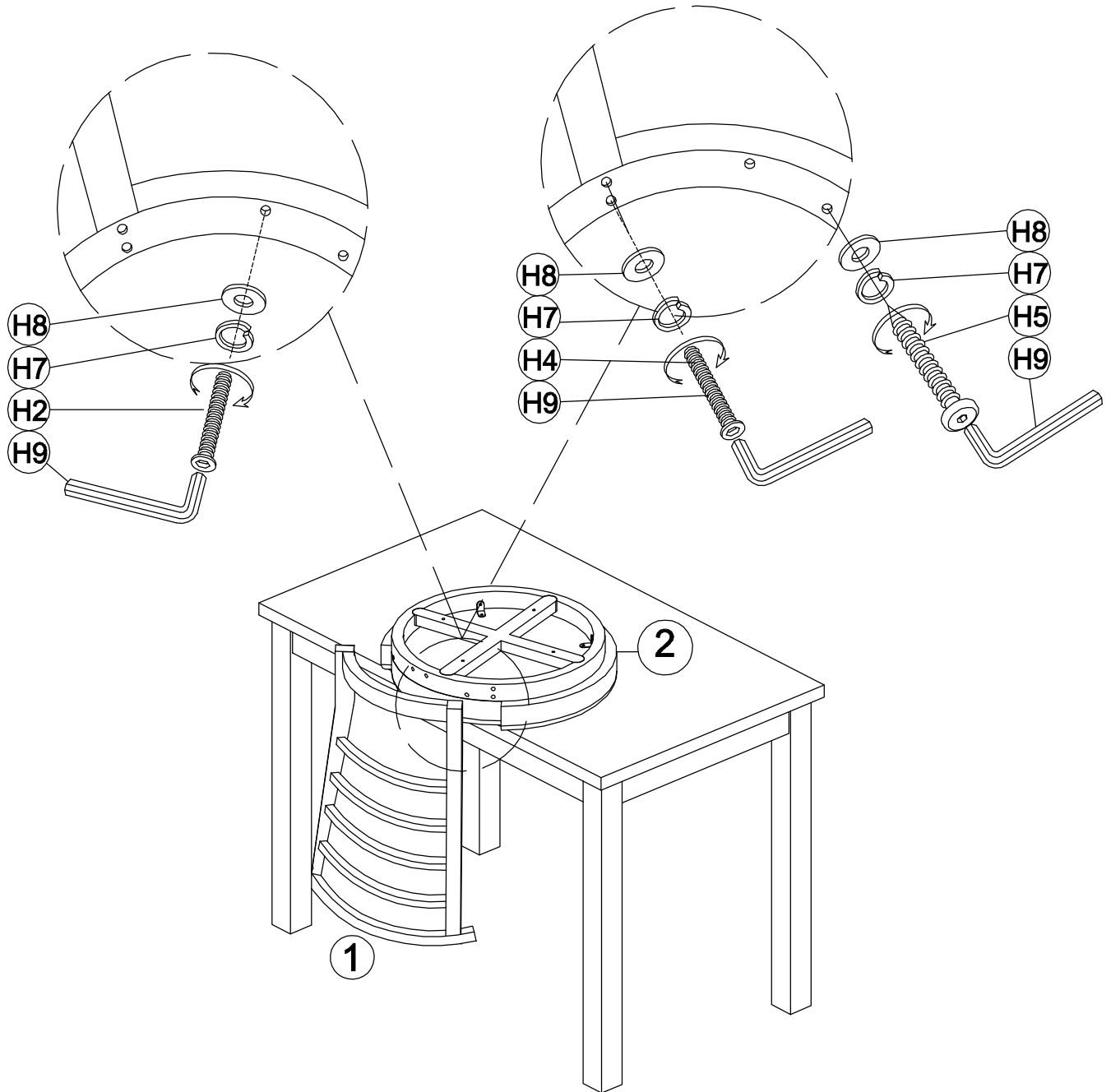

H2		2
H4		4
H5		2
H7		8
H8		8
H9		1

STEP 2
ÉTAPE 2
PASO 2

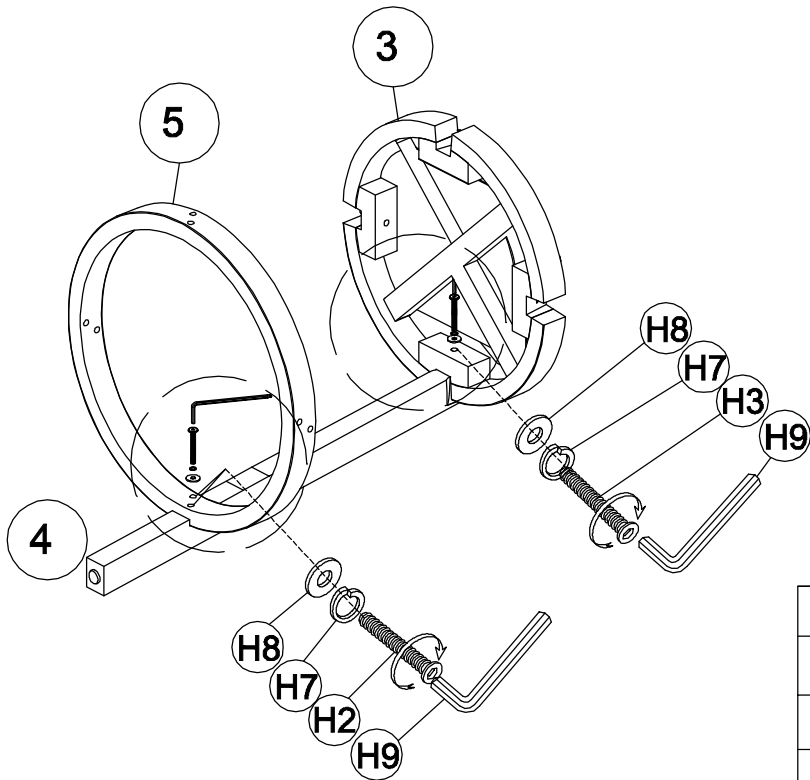

H2		2
H3		1
H7		3
H8		3
H9		1

STEP 3
ÉTAPE 3
PASO 3

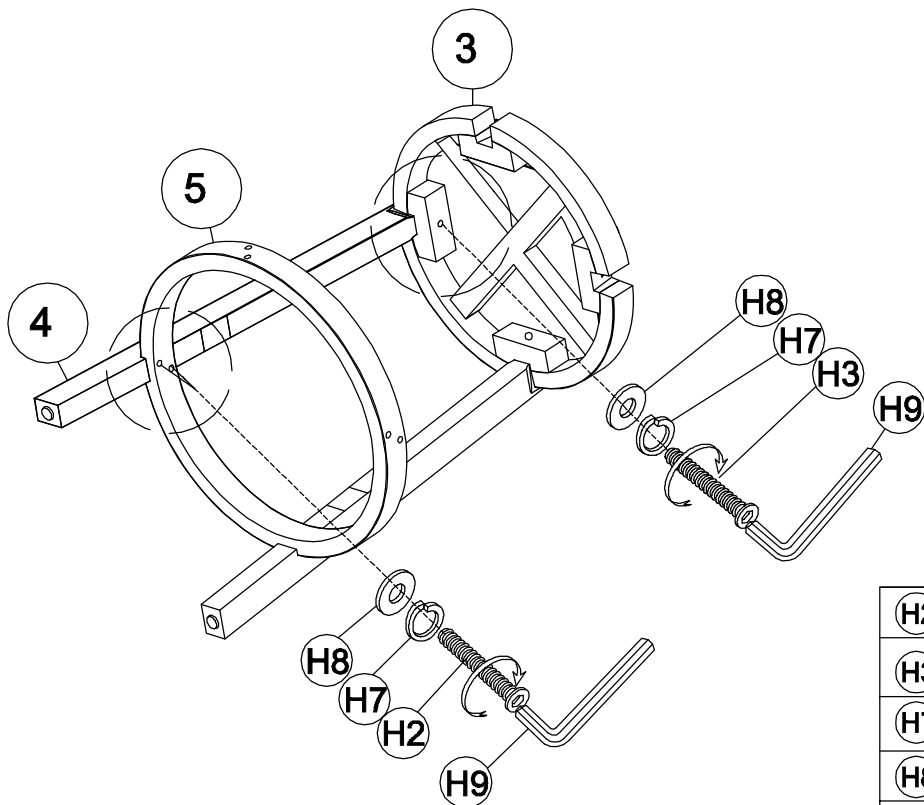

H2		2
H3		1
H7		3
H8		3
H9		1

STEP 4
ÉTAPE 4
PASO 4

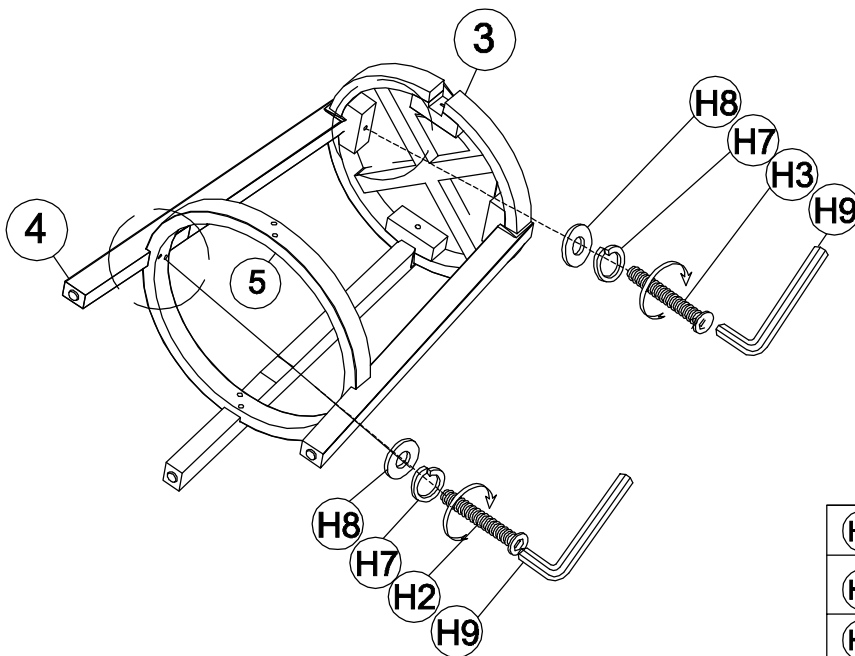

H2		2
H3		1
H7		3
H8		3
H9		1



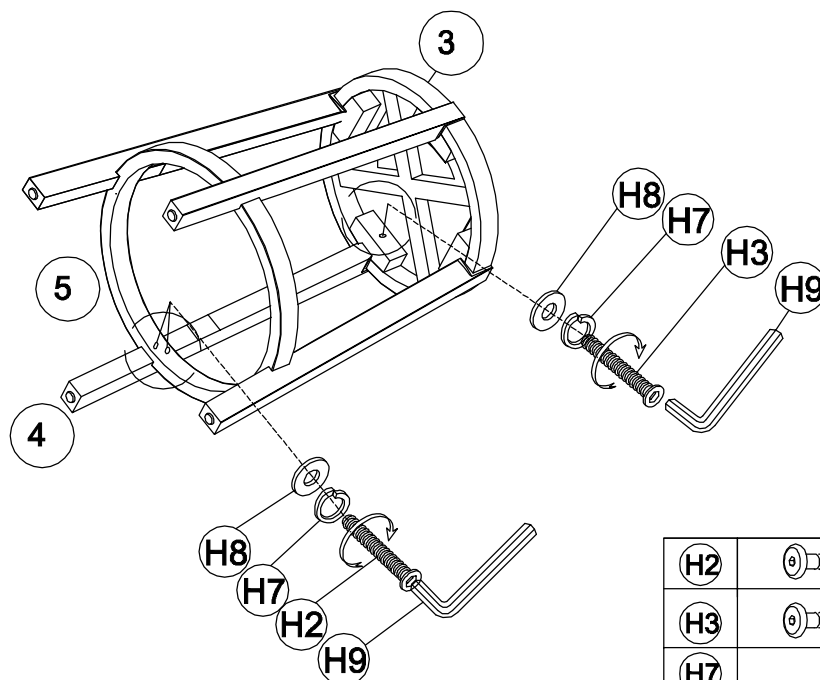

STEP 5
ÉTAPE 5
PASO 5

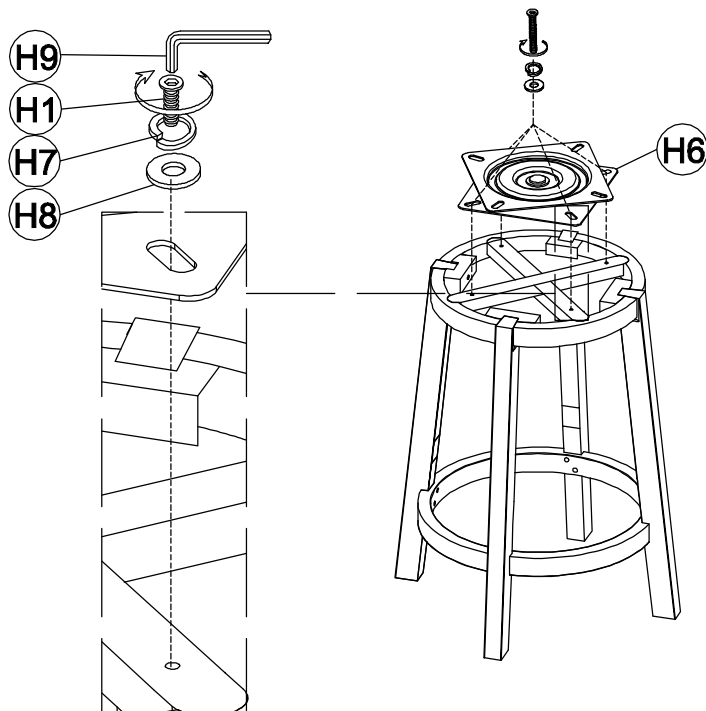

H2		2
H3		1
H7		3
H8		3
H9		1





STEP 6
ÉTAPE 6
PASO 6

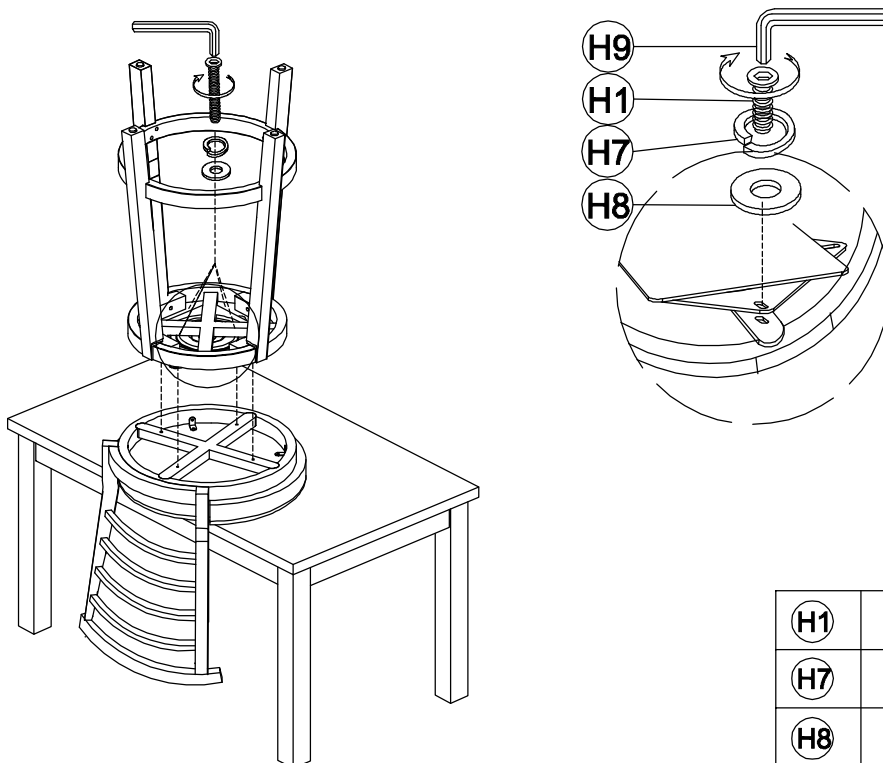

H1		4
H6		1
H7		4
H8		4
H9		1

STEP 7
ÉTAPE 7
PASO 7



H1		4
H7		4
H8		4
H9		1

STEP 8
ÉTAPE 8
PASO 8

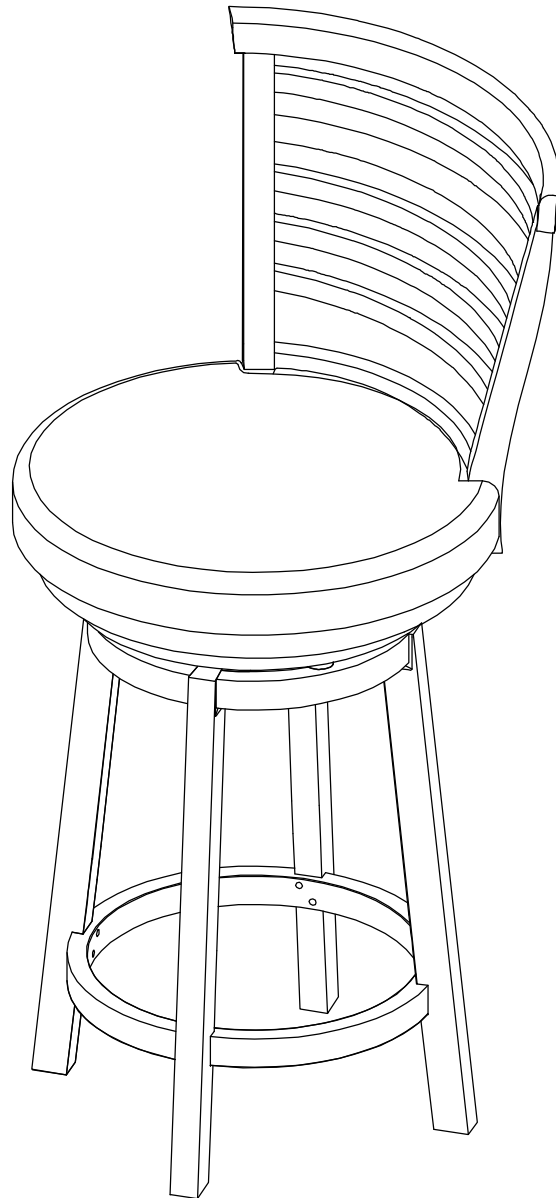

**LIMITED WARRANTY
GARANTIE LIMITÉE
GARANTÍA LIMITADA**

**MADE IN VIETNAM
FABRIQUÉ AU VIETNAM
HECHO EN VIETNAM**

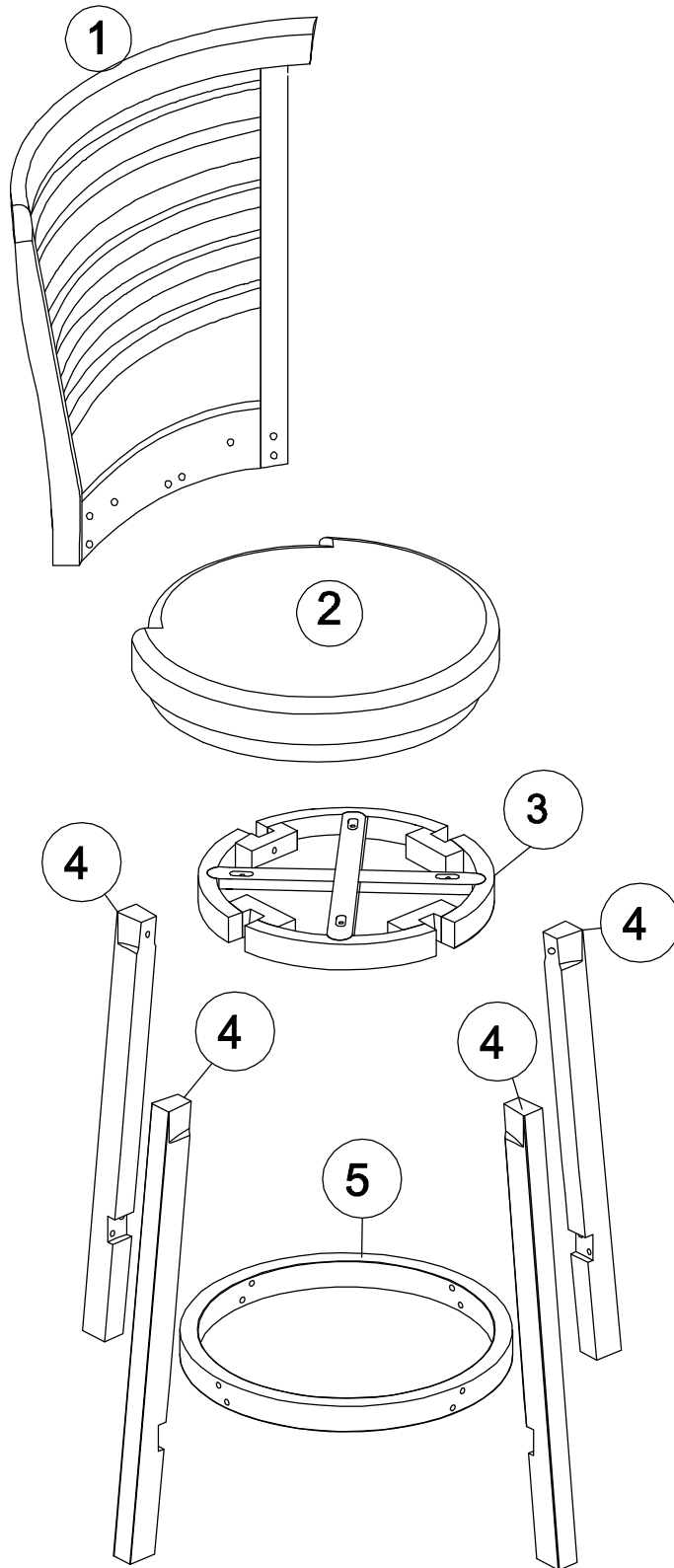



H1 Bolt Ø 1/4"x1-3/16"
(8 pcs)

Boulon Ø 1/4pox2-1/4po
(8 pièces)

Tornillo Ø 1/4"x2-1/2"
(8 piezas)



H2 Bolt Ø 1/4"x1-3/4"
(10 pcs)

Boulon Ø1/4pox1-3/4po
(10 pièces)

Tornillo Ø1/4"x1-3/4"
(10 piezas)



H3 Bolt Ø1/4"x2-3/16"
(4 pcs)

Boulon Ø1/4pox2-3/16po
(4 pièces)

Tornillo Ø1/4"x2-3/16"
(4 piezas)



H4 Bolt Ø 1/4"x2-3/8"
(4 pcs)

Boulon Ø 1/4pox2-3/8po
(4 pièces)

Tornillo Ø 1/4"x2-3/4"
(4 piezas)



H5 Wood Screw Ø 1/4"x1-3/4"
(2 pcs)

Vis À Tête Plate Ø1/4pox1-3/4po
(2 pièces)

Tornillo De Cabeza Redonda
Ø1/4"x1-3/4"
(2 piezas)

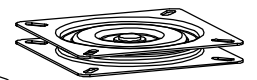

H6 Swivel plate
(1pc)

Plaque pivotante
(1 pièce)

Placa giratoria
(1 pieza)



H7 Spring Washer Ø1/4"
(28 pcs)

Rondelle à ressort Ø1/4po
(28 pièces)

Arandela de resorte Ø1/4"
(28 piezas)



H8 Flat Washer Ø1/4"
(28 pcs)

Rondelle plate Ø1/4po
(28 pièces)

Arandela plana Ø1/4"
(28 piezas)

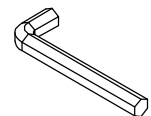

H9 Allen Key 4mm
(1pc)

Clé Allen 4mm
(1 pièce)

Liave Allen 4mm
(1pieza)

STEP 1
ÉTAPE 1
PASO 1

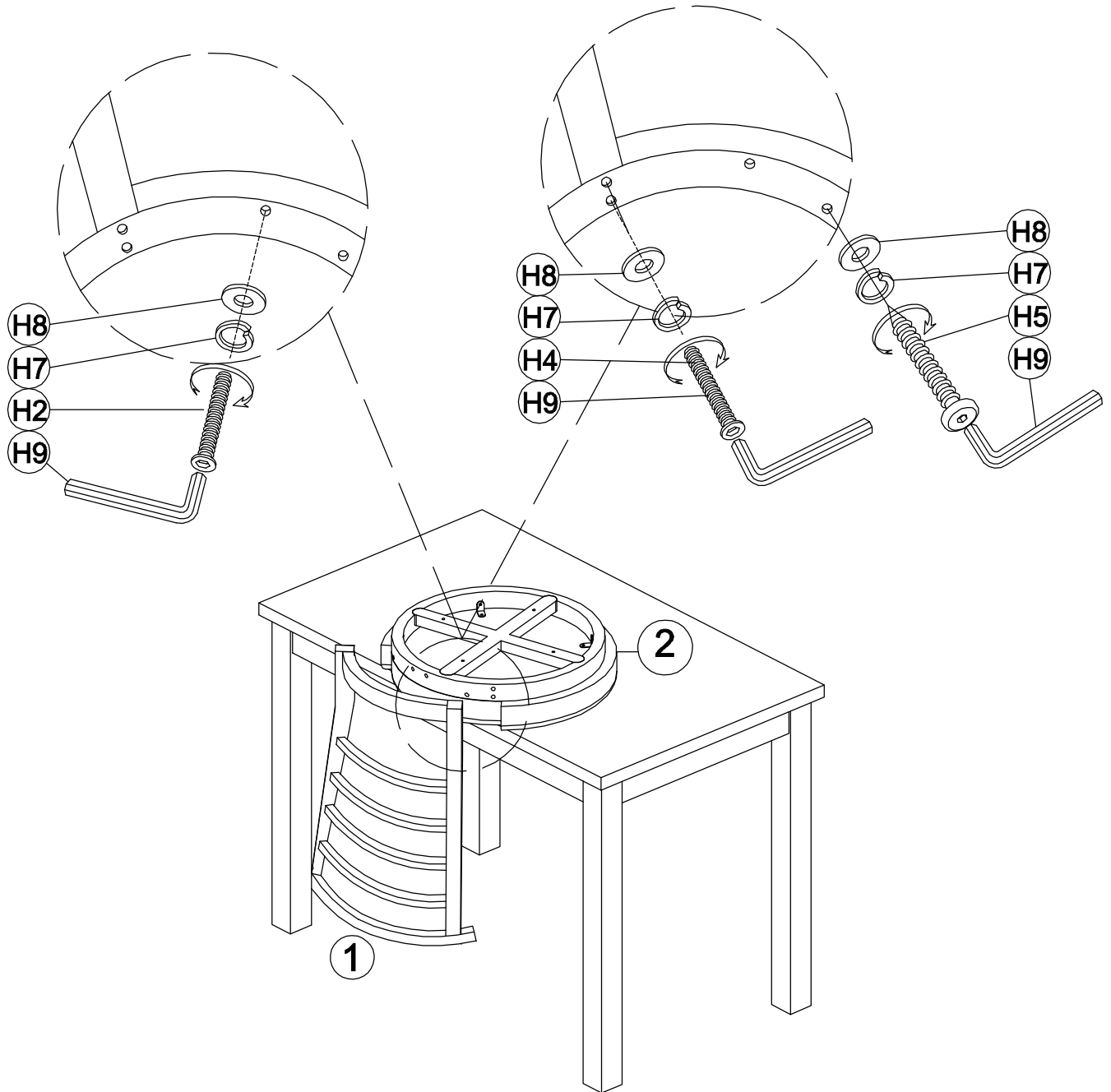

H2		2
H4		4
H5		2
H7		8
H8		8
H9		1

STEP 2
ÉTAPE 2
PASO 2

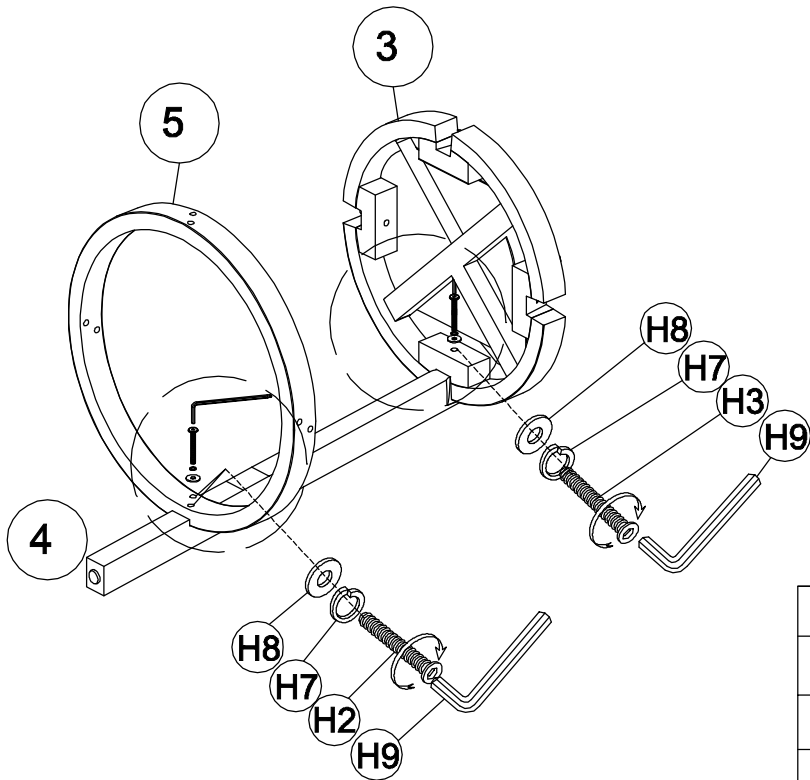

H2		2
H3		1
H7		3
H8		3
H9		1

STEP 3
ÉTAPE 3
PASO 3

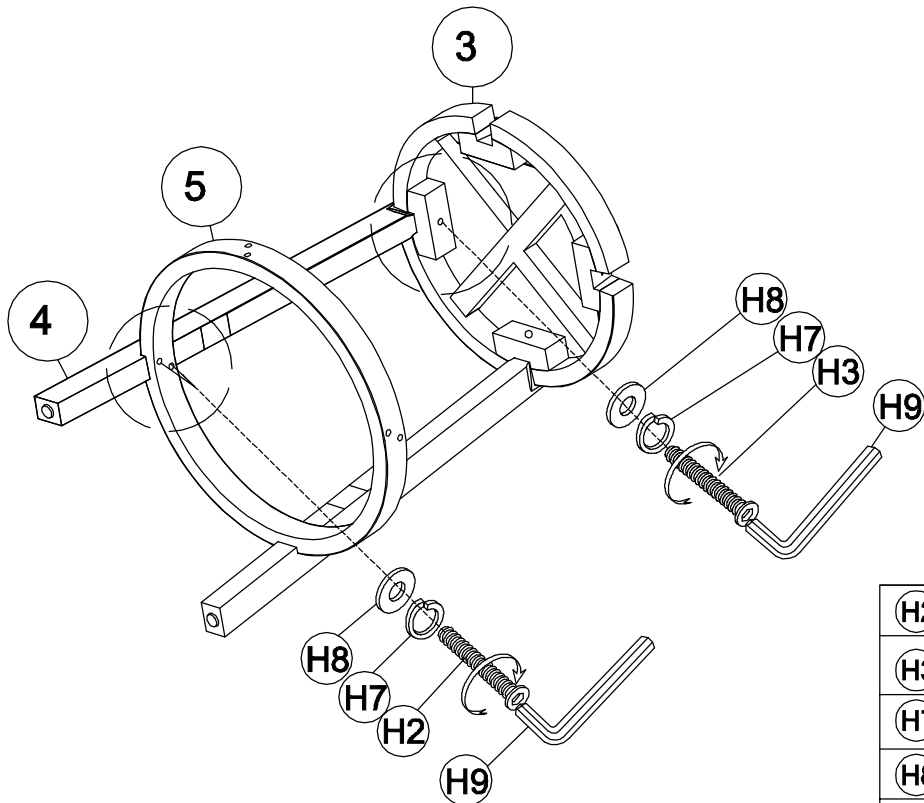

H2		2
H3		1
H7		3
H8		3
H9		1

STEP 4
ÉTAPE 4
PASO 4

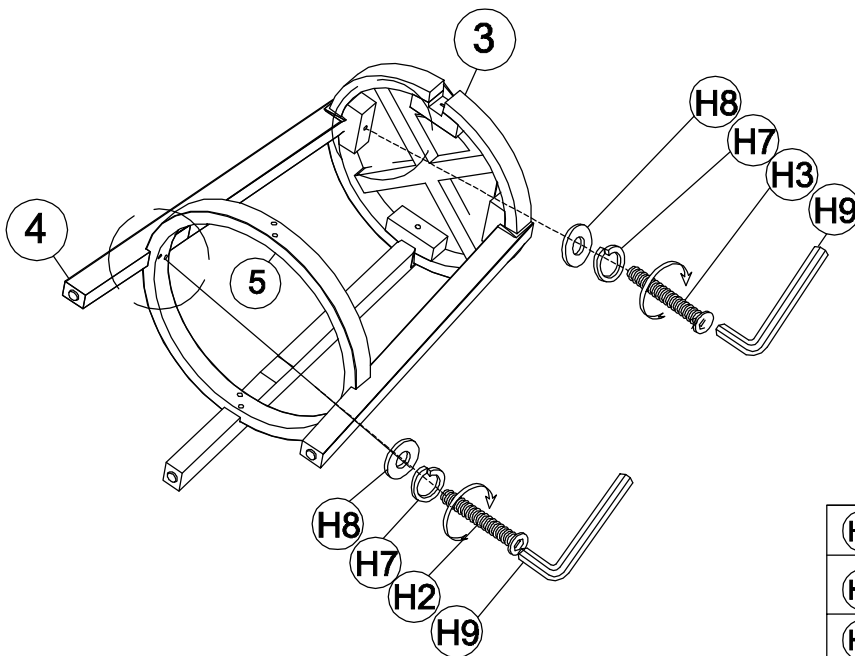

H2		2
H3		1
H7		3
H8		3
H9		1



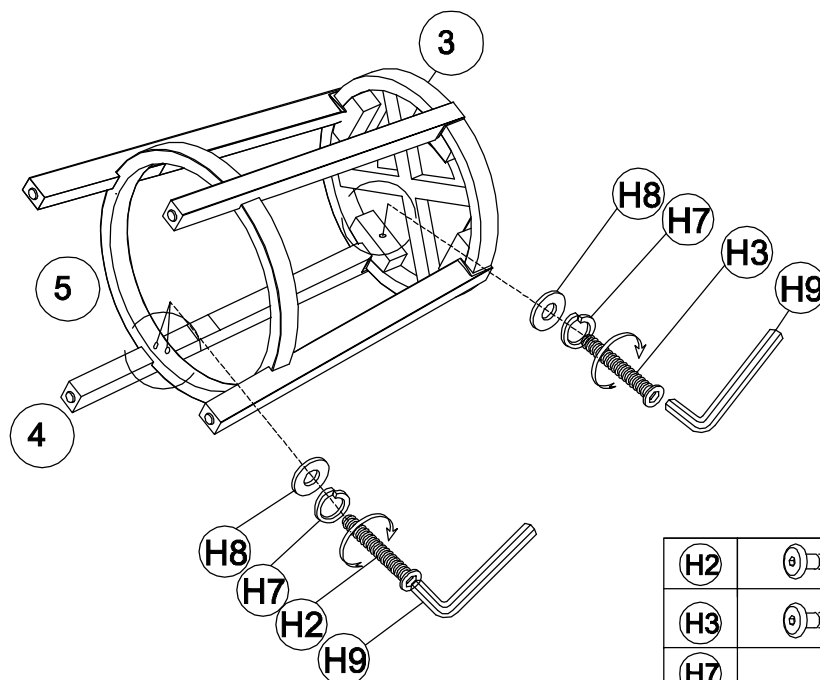

STEP 5
ÉTAPE 5
PASO 5

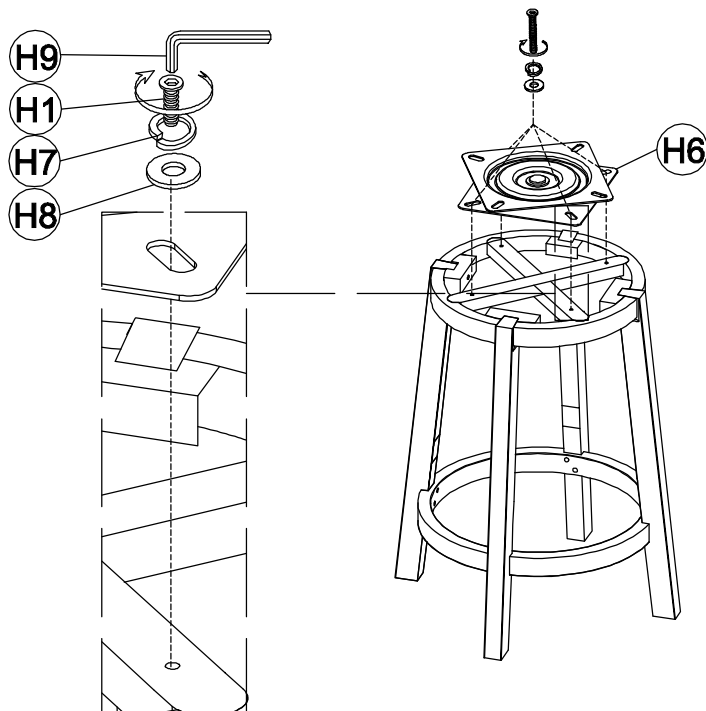

H2		2
H3		1
H7		3
H8		3
H9		1





STEP 6
ÉTAPE 6
PASO 6

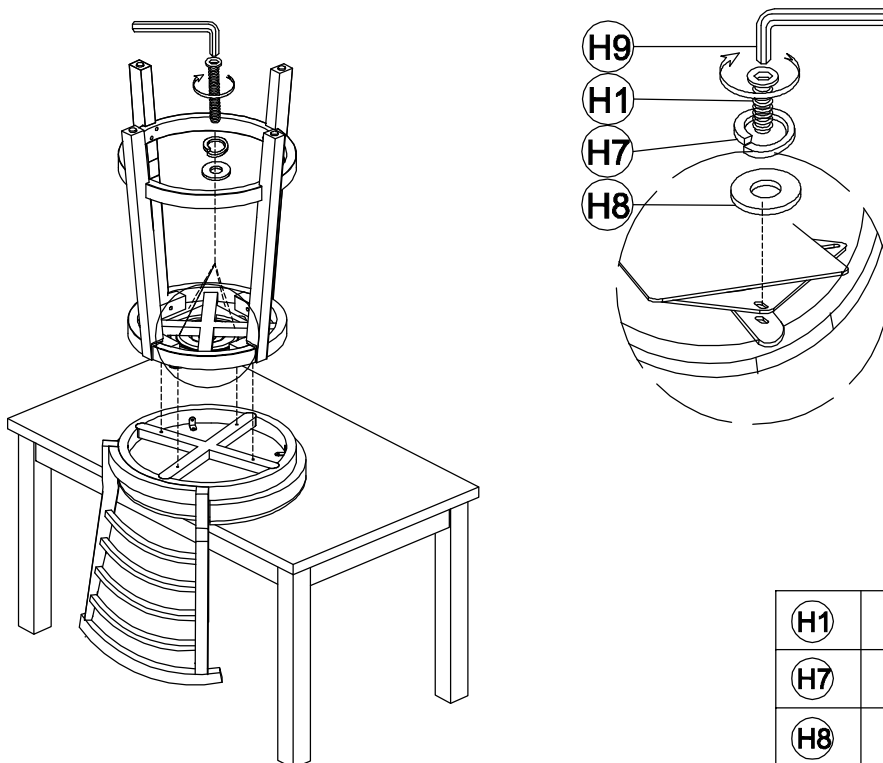

H1		4
H6		1
H7		4
H8		4
H9		1

STEP 7
ÉTAPE 7
PASO 7



H1		4
H7		4
H8		4
H9		1

STEP 8
ÉTAPE 8
PASO 8

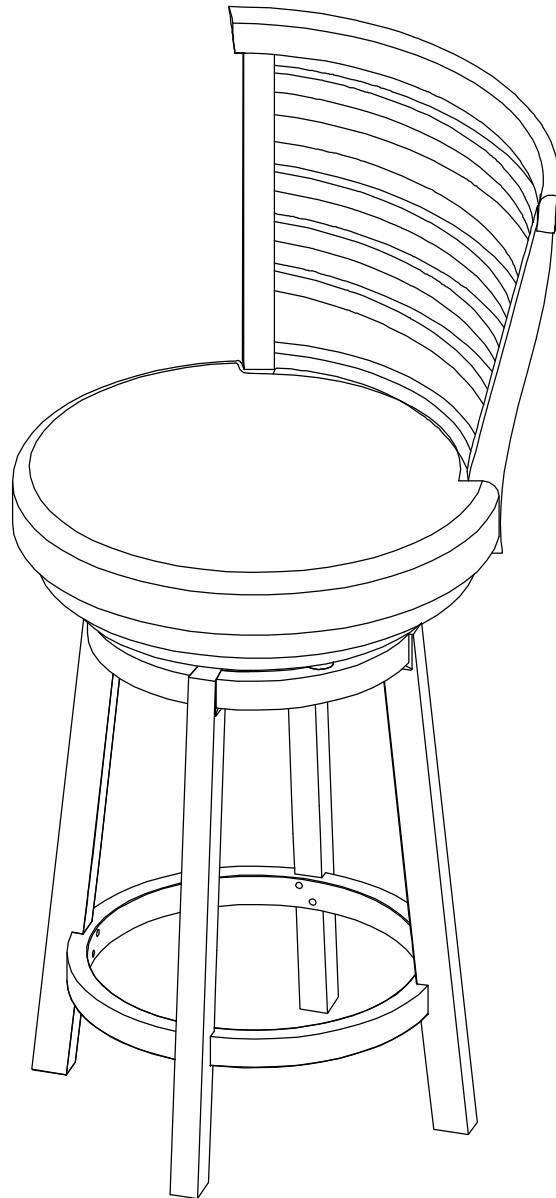

**LIMITED WARRANTY
GARANTIE LIMITÉE
GARANTÍA LIMITADA**

**MADE IN VIETNAM
FABRIQUÉ AU VIETNAM
HECHO EN VIETNAM**

