

ASSEMBLY INSTRUCTION

SKU CODE:N709P206565C

N709P206566C

INSTRUCTIONS DE MONTAGE

CODE UGS :N709P206565C

N709P206566C

TWIN DAYBED WITH TRUNDLE

LIT SIMPLE TIRABLE

This set included 2 boxex if do not receive full 2 boxex. Please contact our customer service team

Cet ensemble comprenait 2 boxex si vous ne recevez pas 2 boxex complets. Veuillez contacter notre service client

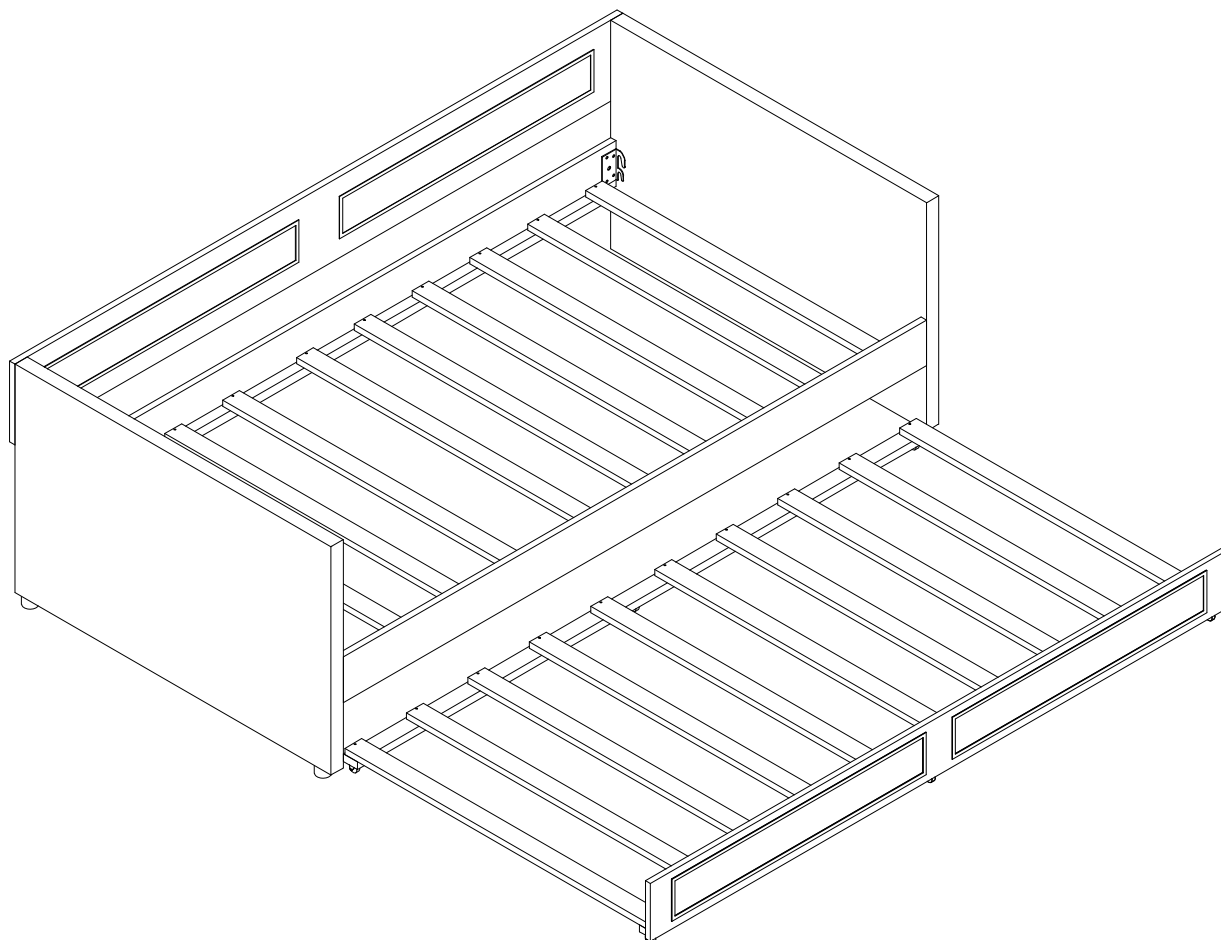

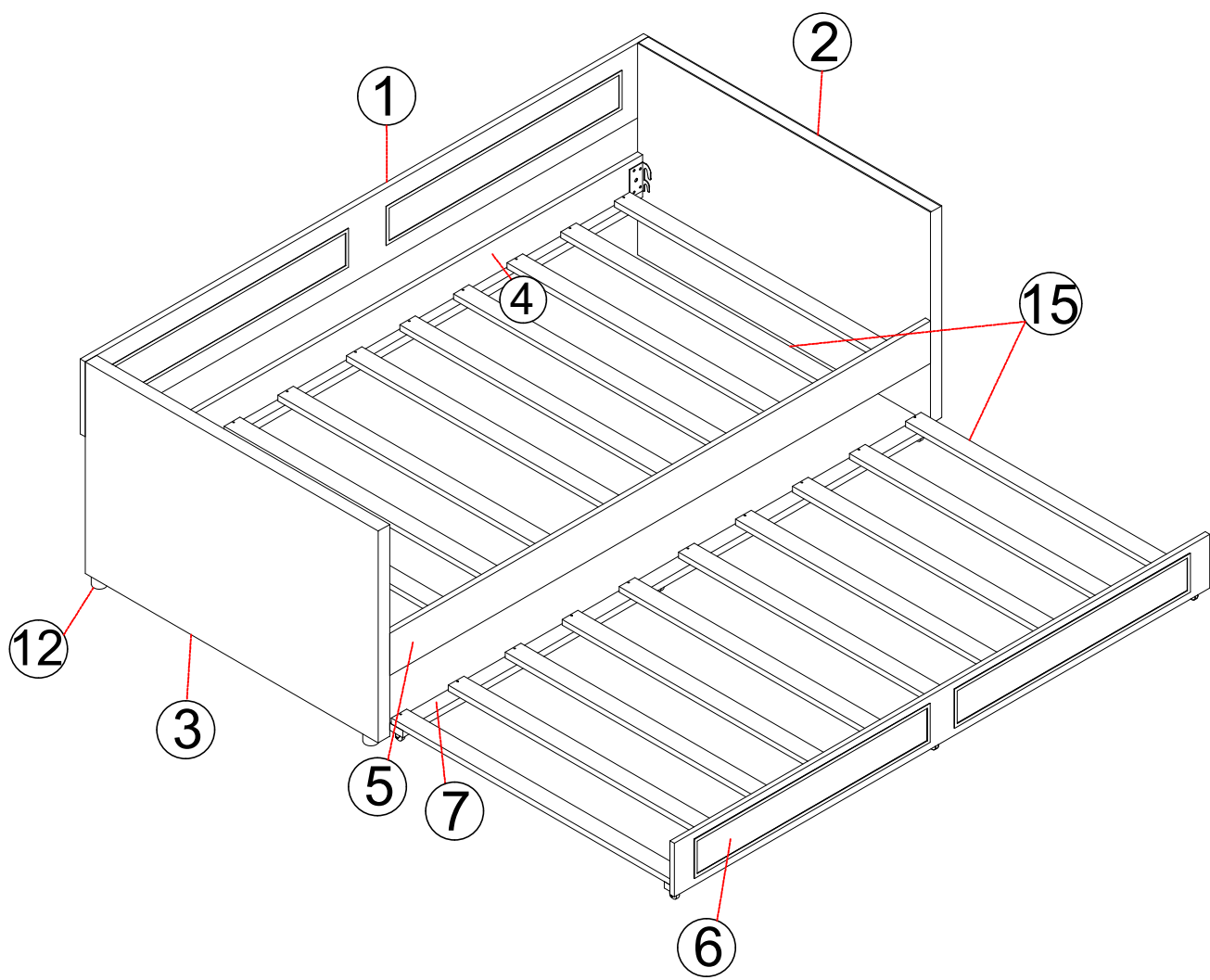

Part List

(Liste des pièces)

BOX 1/2:N709P206565C

ENCADRÉ 1/2 :N709P206565C

2

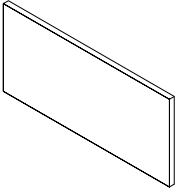

Side board Right -1pc
Buffet latéral droit -1 pièce

3

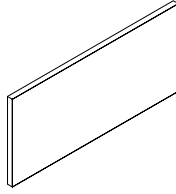

Side board Left -1pc
Buffet latéral gauche - 1 pièce

15

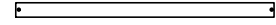

Slates- 6 pcs
Barres de support - 6 pièce

BOX 2/2: N709P206566C

ENCADRÉ 1/2 :N709P206566C

1

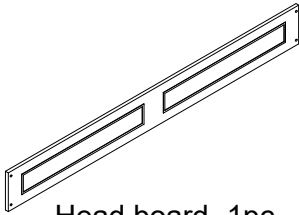

Head board -1pc
Tête de lit - 1 pièce

4

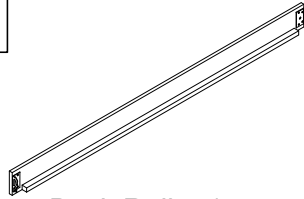

Back Rails -1pc
Rail arrière - 1 pièce

5

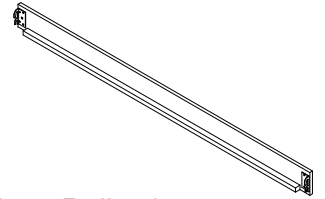

Front Rails -1pc
Rails avant - 1 pièce

6

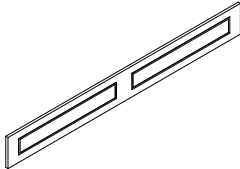

Drawer front -1pc
Facade de tiroir - 1 pièce

7

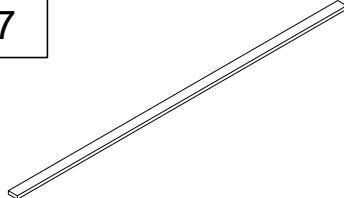

Support behind the drawer -1pc
Support derrière les tiroirs -1 pièce

12



Legs - 4pcs
Jambe-4 pièce

15

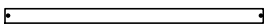

Slates- 14 pcs
Barres de support - 14 pièce









Hardware
(Matériel)

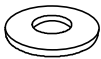

HARDWARE

Check that you've received
all hardware listed below

Hardware List (Liste du matériel)

No.	OUTLOOK (PERSPECTIVES)	NOTE	QTY
(A)		Bolts 5/16"x35 mm (Boulons 5/16"x 35 mm)	4
(B)		Bolts 5/16"x30 mm (Boulons 5/16"x30 mm)	12
(C)		Spring washer Ø5/16"x12 mm (Rondelle élastiquer Ø5/16"x12 mm)	12
(D)		Allen key 80x25x4 mm (clé Alle`n 80x25x4 mm)	1
(E)		Bolts 5/16"x30 mm (Boulons 5/16"x30 mm)	8
(F)		Screws Ø4x30 mm (Des vis Ø4x30 mm)	40
(G)		Screws Ø4x15 mm (Des vis Ø4x15 mm)	20
(L)		LINKED METAL (Métal lié)	2
(H)		Wheel (Roue)	6

STEP 1 (ÉTAPE 1)

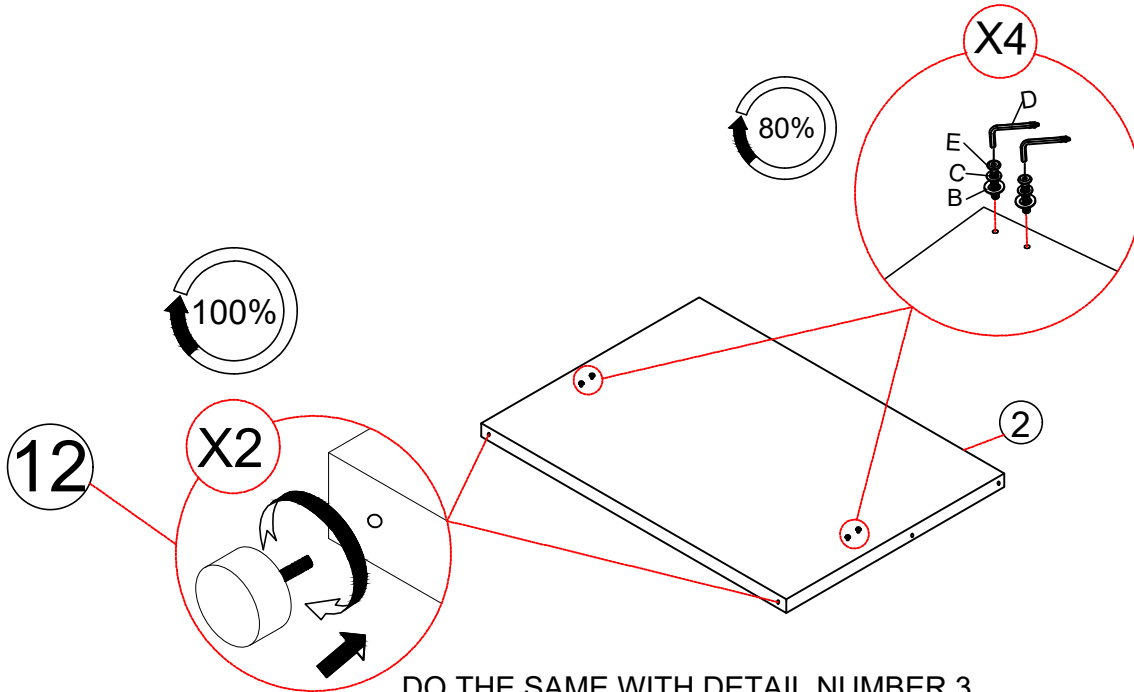
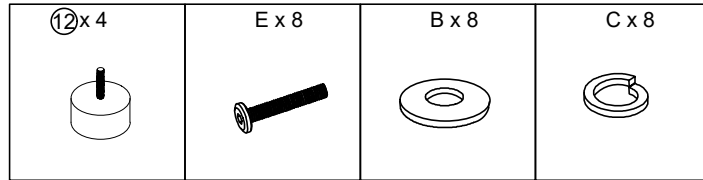

DO THE SAME WITH DETAIL NUMBER 3
FAITES LA MÊME AVEC LE DÉTAIL NUMÉRO 3

STEP 2 (ÉTAPE 2)

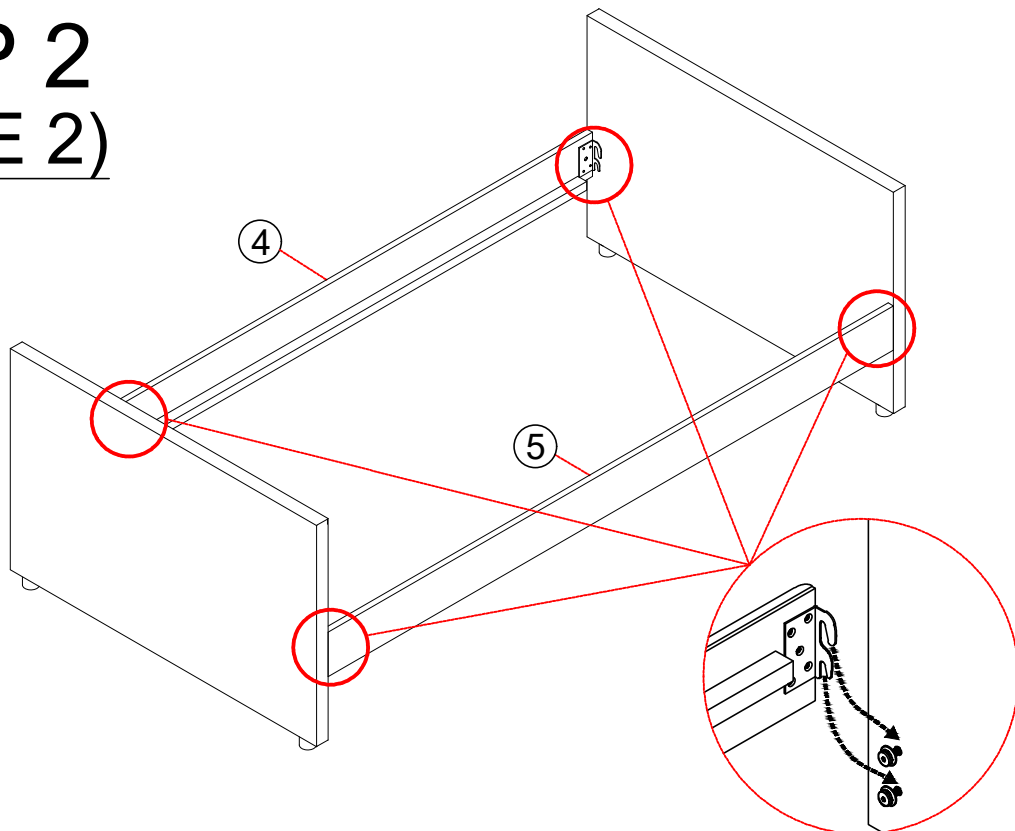

STEP 3 (ÉTAPE 3)

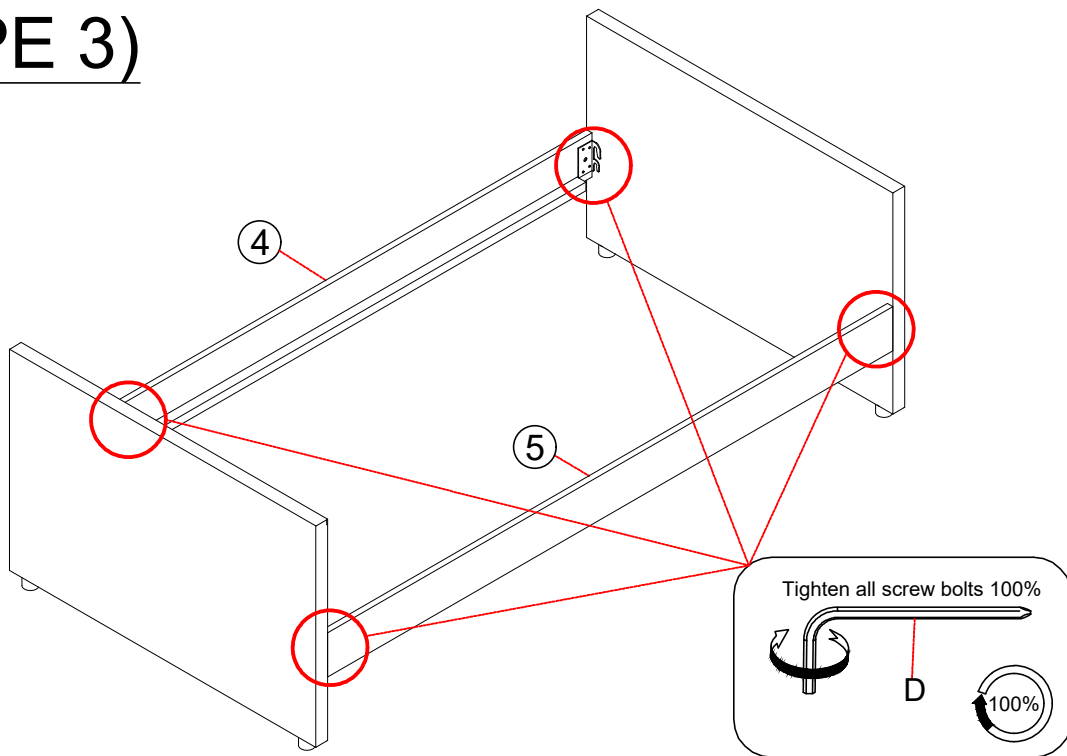

STEP 4 (ÉTAPE 4)

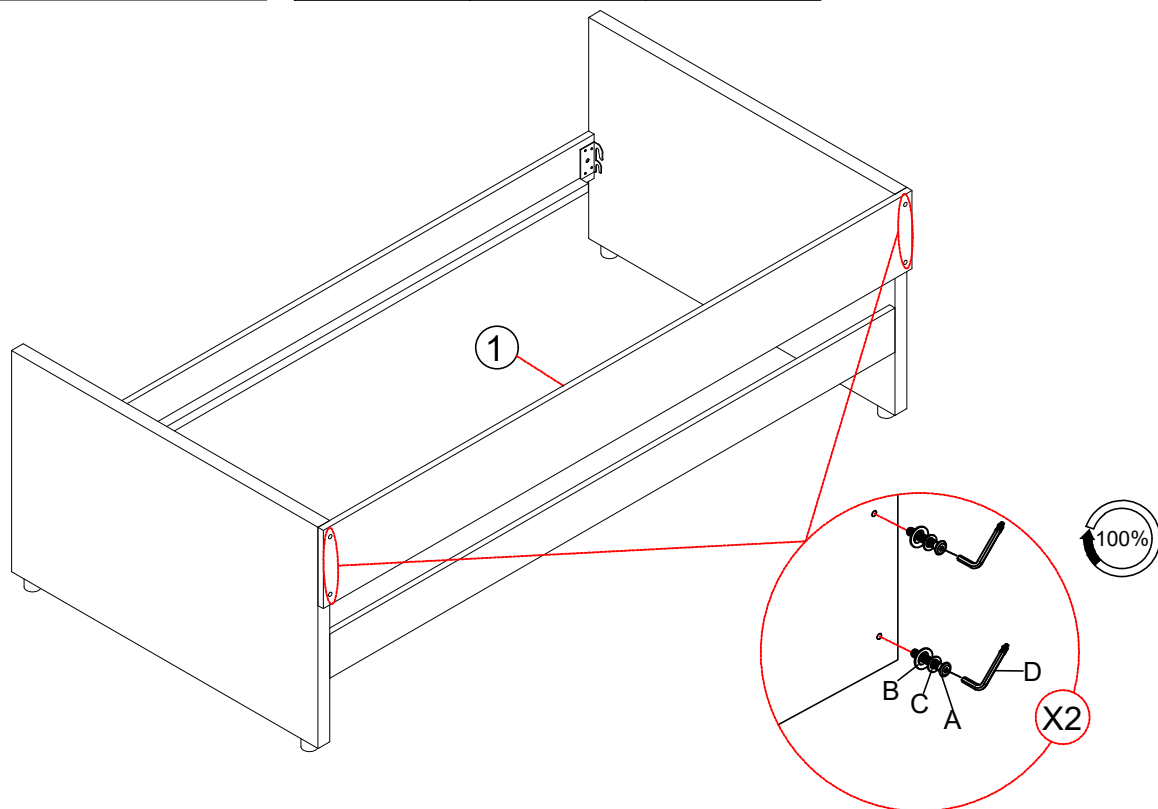
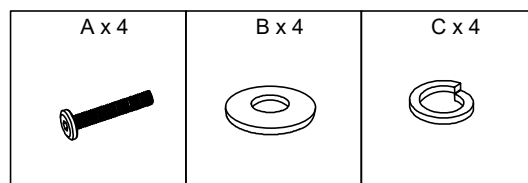

STEP 5 (ÉTAPE 5)

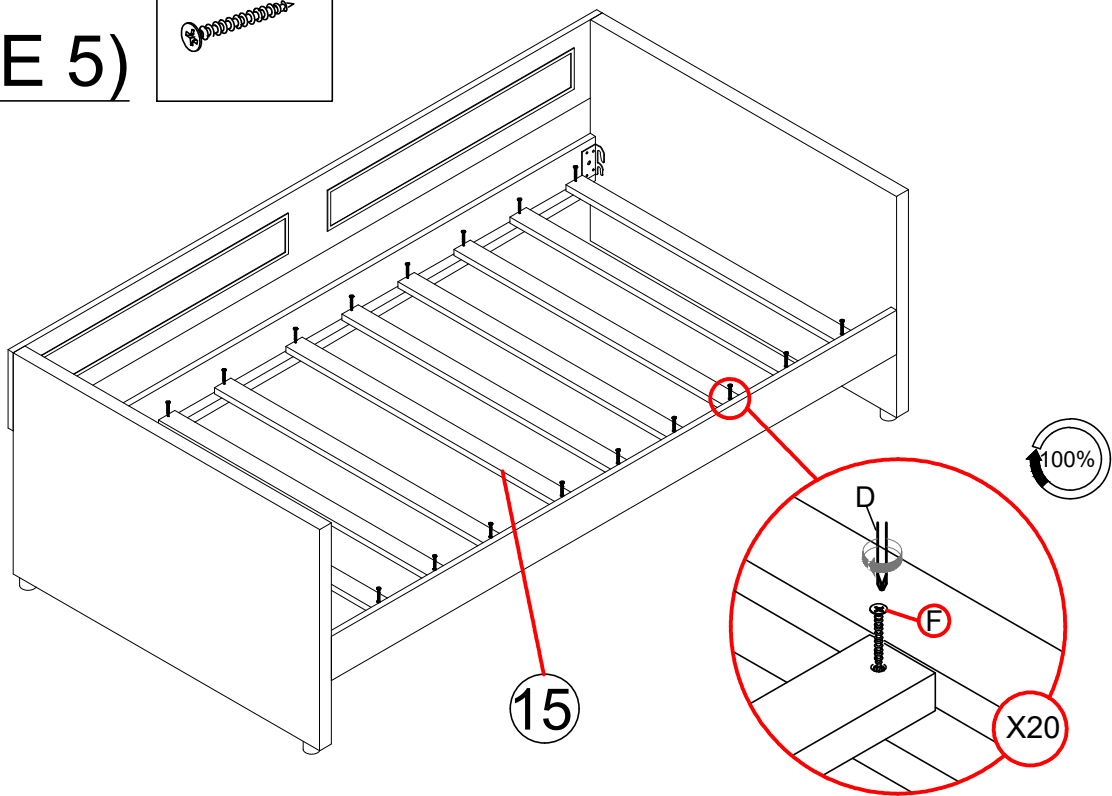
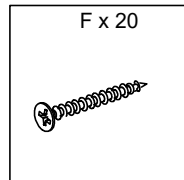

STEP 6 (ÉTAPE 6)

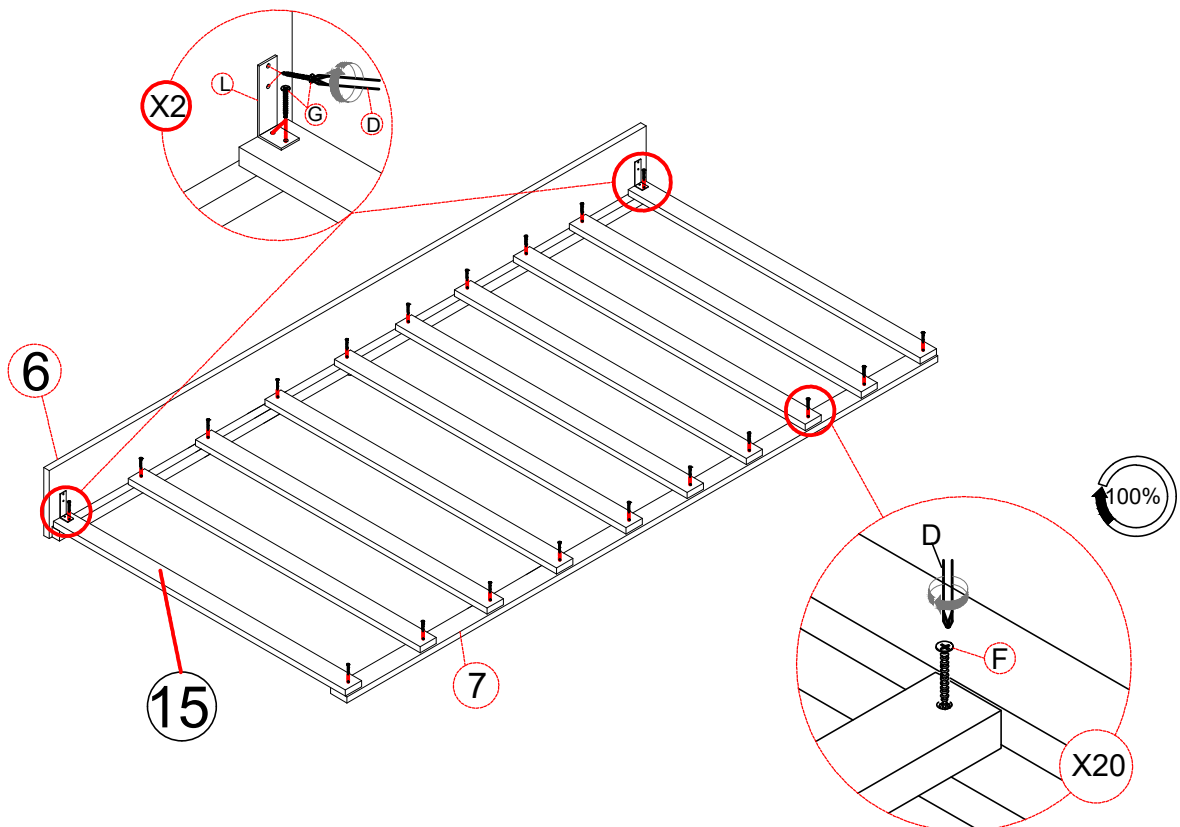
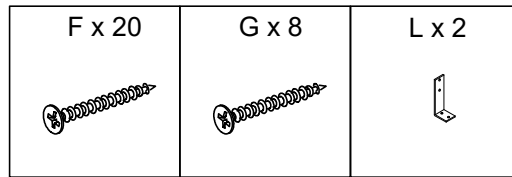

STEP 7

(ÉTAPE 7)

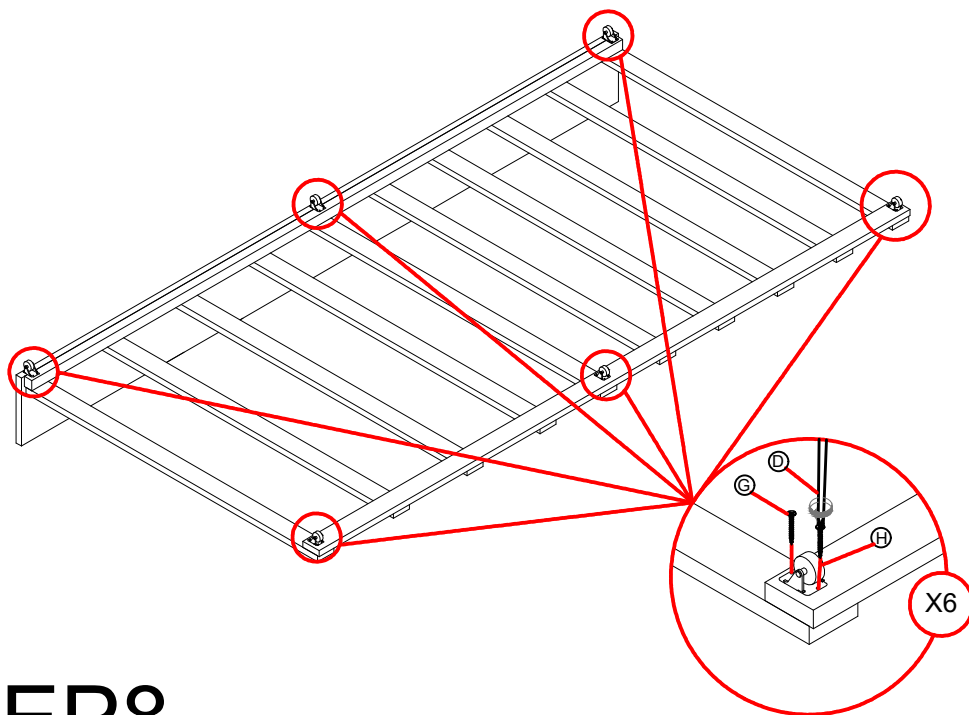
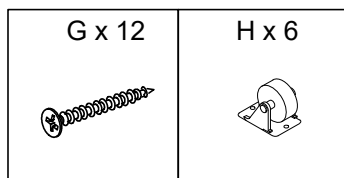

STEP 8

(ÉTAPE 8)

