

INSTRUCTION MANUAL

3-Seat Converting
Outdoor Swing

! NOTICE

Please retain these instructions for future reference.

- Please do not exceed the weight limitations of this item.
- Do not stand on or use any part of this item as a step ladder.
- Firmly secure all bolts, screws and knobs before use.
- Reconfirm that all bolts, screws, and knobs are secure every 90 days.
- Fasten screws loosely during initial assembly. Do not firmly tighten the screws until the item is completely assembled.
- Be aware that some parts are heavy and have sharp edges.
- If any parts are missing, broken, damaged, or worn, stop using this product until repairs are made and/or factory replacement parts are installed.
- Do not use this item in a way inconsistent with the manufacturer's instructions as this could void the product warranty.

TOOLS REQUIRED



ALLEN WRENCH
(PROVIDED)



WRENCH
(PROVIDED)



750 LBS
CAPACITY



2 PERSON
ASSEMBLY



UP TO 60 MIN.
ASSEMBLY

HARDWARE

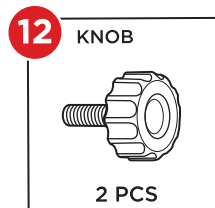
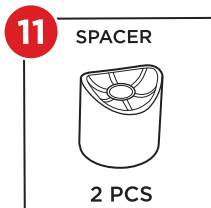
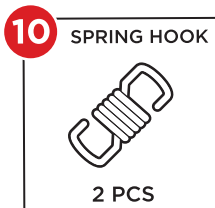
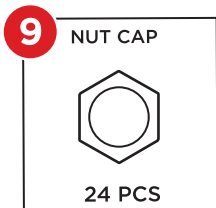
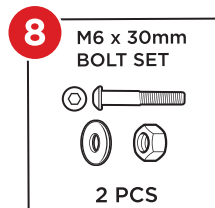
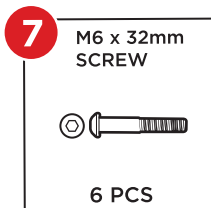
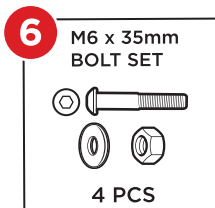
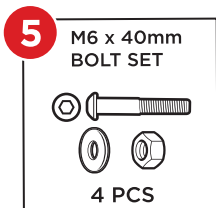
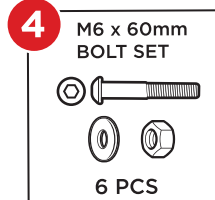
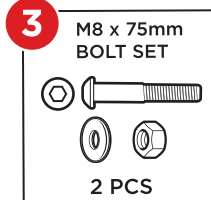
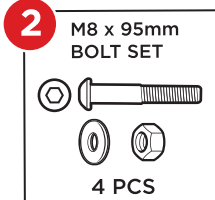
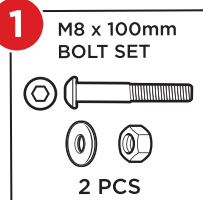

PARTS

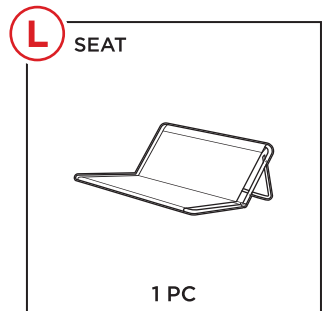
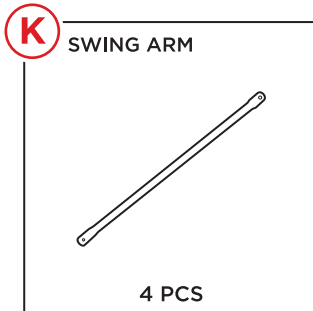
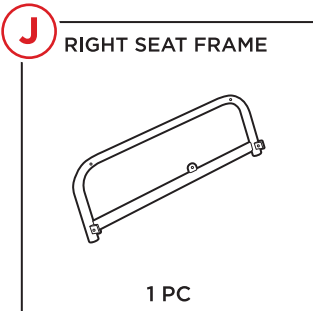
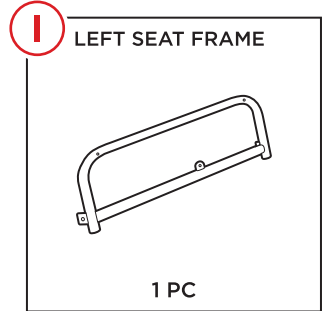
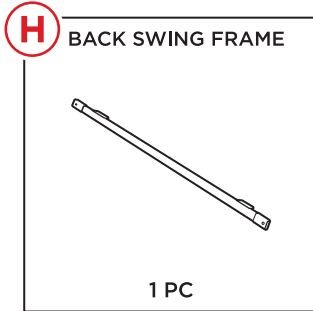
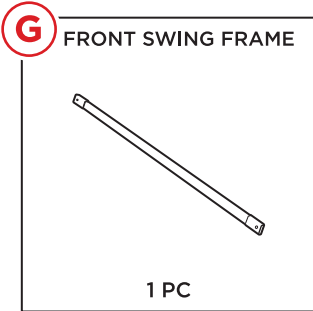
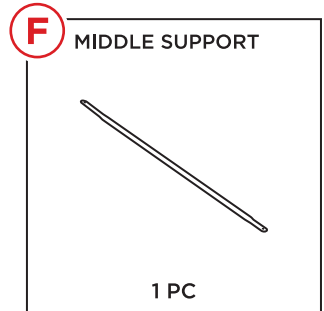
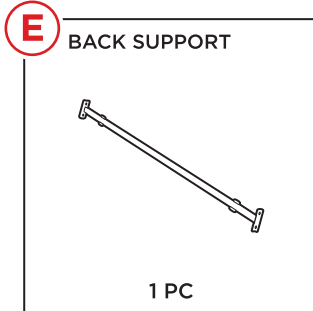
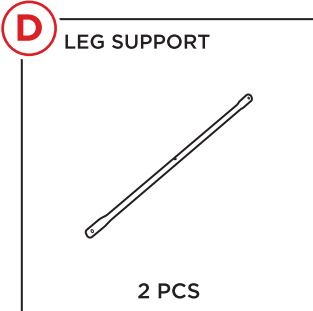
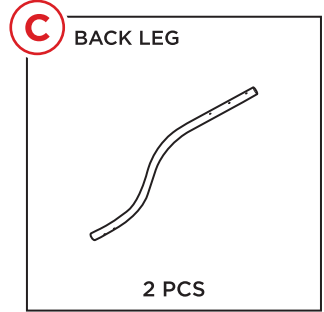
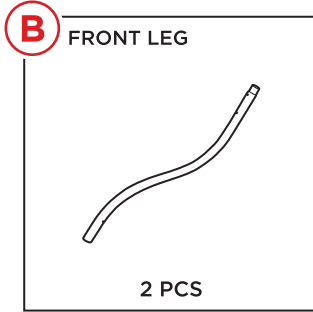
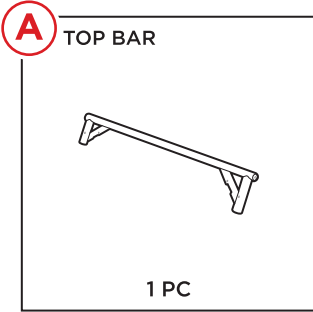

PARTS

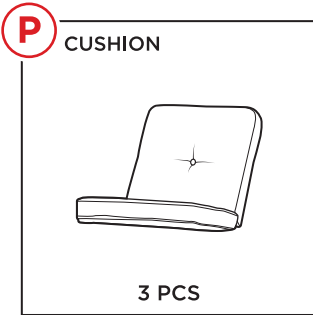
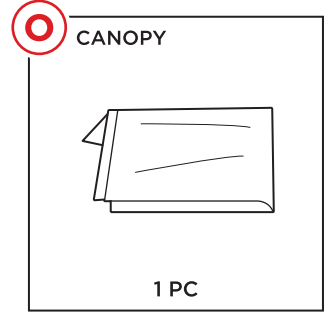
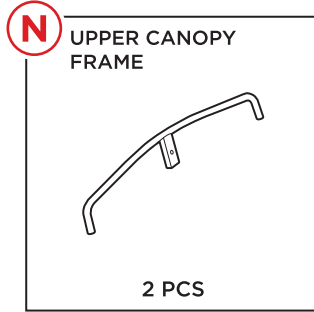
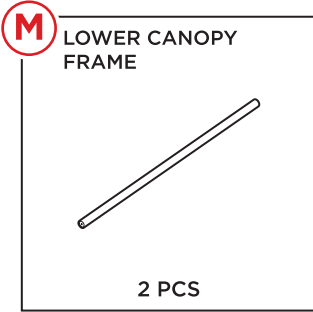

PRODUCT ASSEMBLY

1

Insert a part B front leg into the part A top bar. Attach a part C back leg with a part 1 bolt set and two part 2 bolt sets. Repeat on the other side.

Place a part 9 nut cap on every nut.

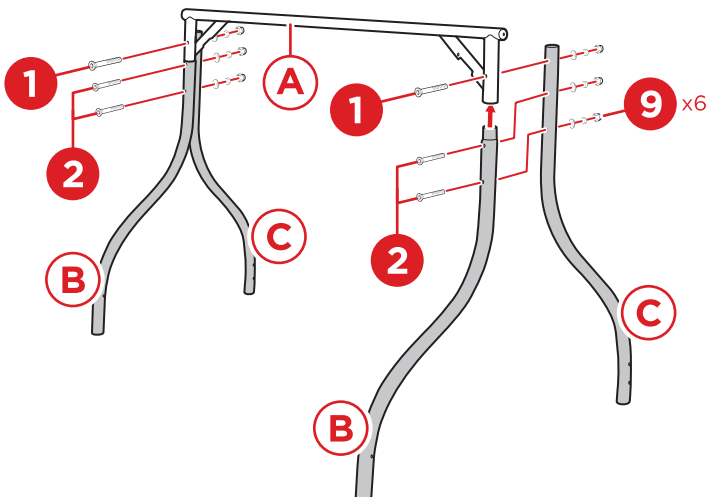

PRODUCT ASSEMBLY

2

Attach a part D leg support and one side of the part E back support to the legs with three part 4 bolt sets. Repeat on the other side.

NOTE: The leg support and back support share a part 4 bolt set.

Attach the part F middle support with two part 8 bolt sets, one on each side.

Place a part 9 nut cap on every nut.

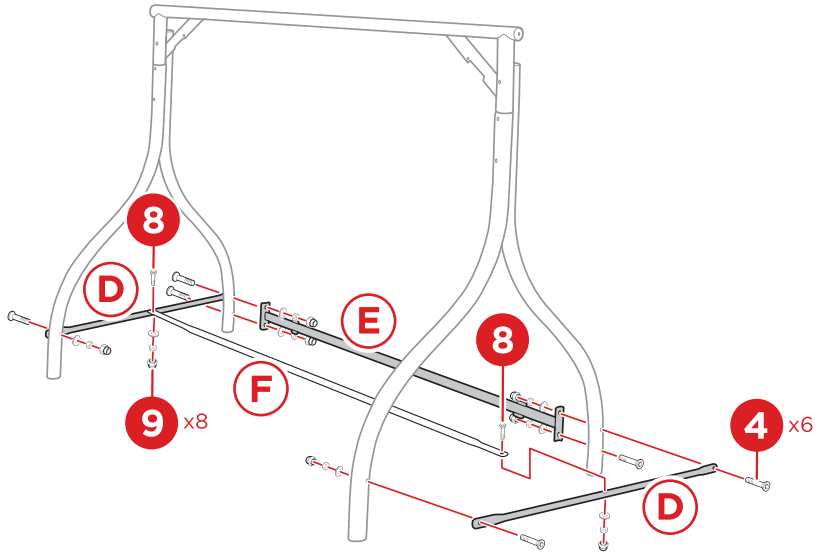

3

Attach the part I left seat frame to the part G front swing frame and part H back swing frame with two part 6 bolt sets. Repeat on the other side to attach the part J right seat frame.

Attach four part K swing arms with four part 5 bolt sets.

Secure the top of the swing arms with two part 10 spring hooks.

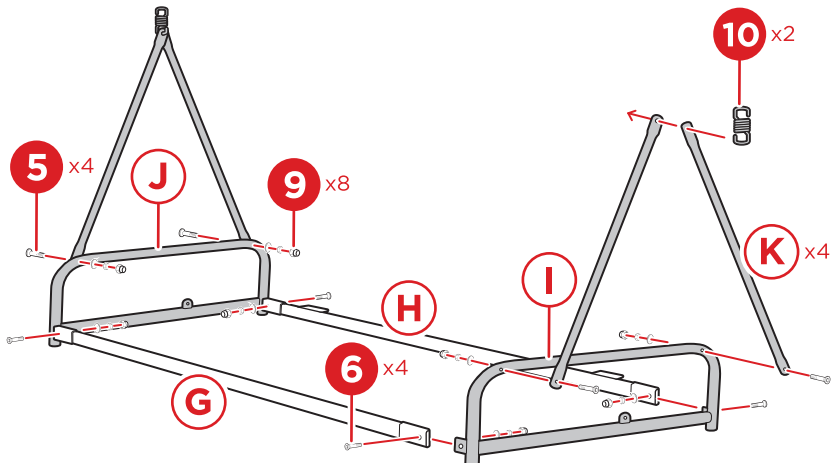

PRODUCT ASSEMBLY

4

Insert the part L seat into the clamps on the back swing frame. Attach the seat with two part 3 bolt sets and two part 11 spacers.

Place a part 9 nut cap on every nut.

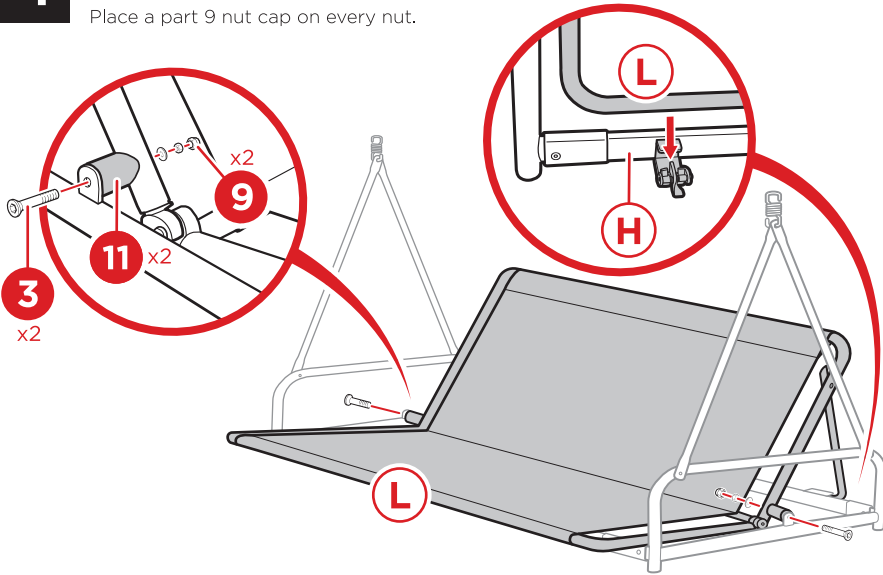

5

Hang the swing by inserting the spring hooks into the designated holes on the top bar.

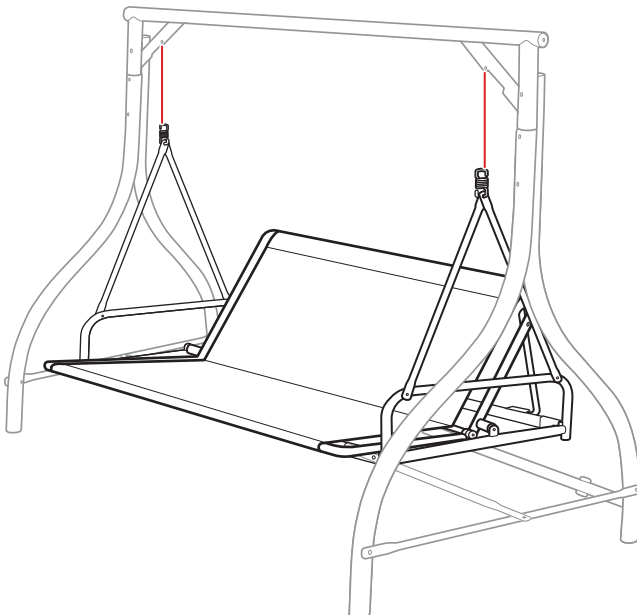

PRODUCT ASSEMBLY

6

Slide a part M lower canopy frame into the slots on the part O canopy.

Within the canopy, attach a part N upper canopy frame with three part 7 screws. Repeat on the other side.

Secure the canopy to the swing with two part 12 knobs, one on each side.

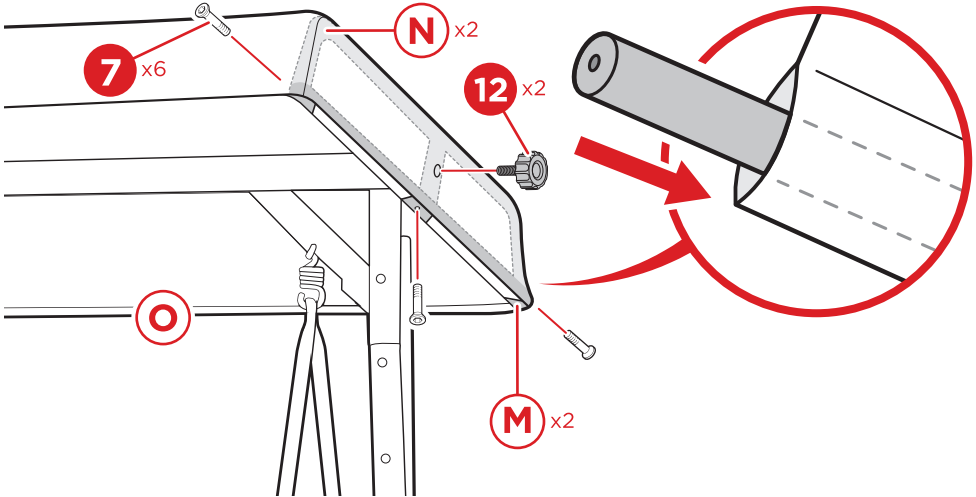

7

Place three part P cushions.

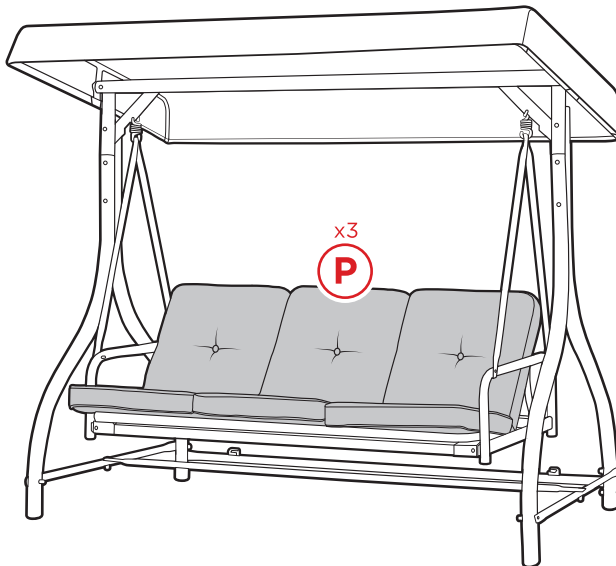

CONVERTING THE SWING

Pull the seat up from the clamps on the back swing frame. Lay the seat flat while sliding the support arm into the designated slots on the rear of the swing.

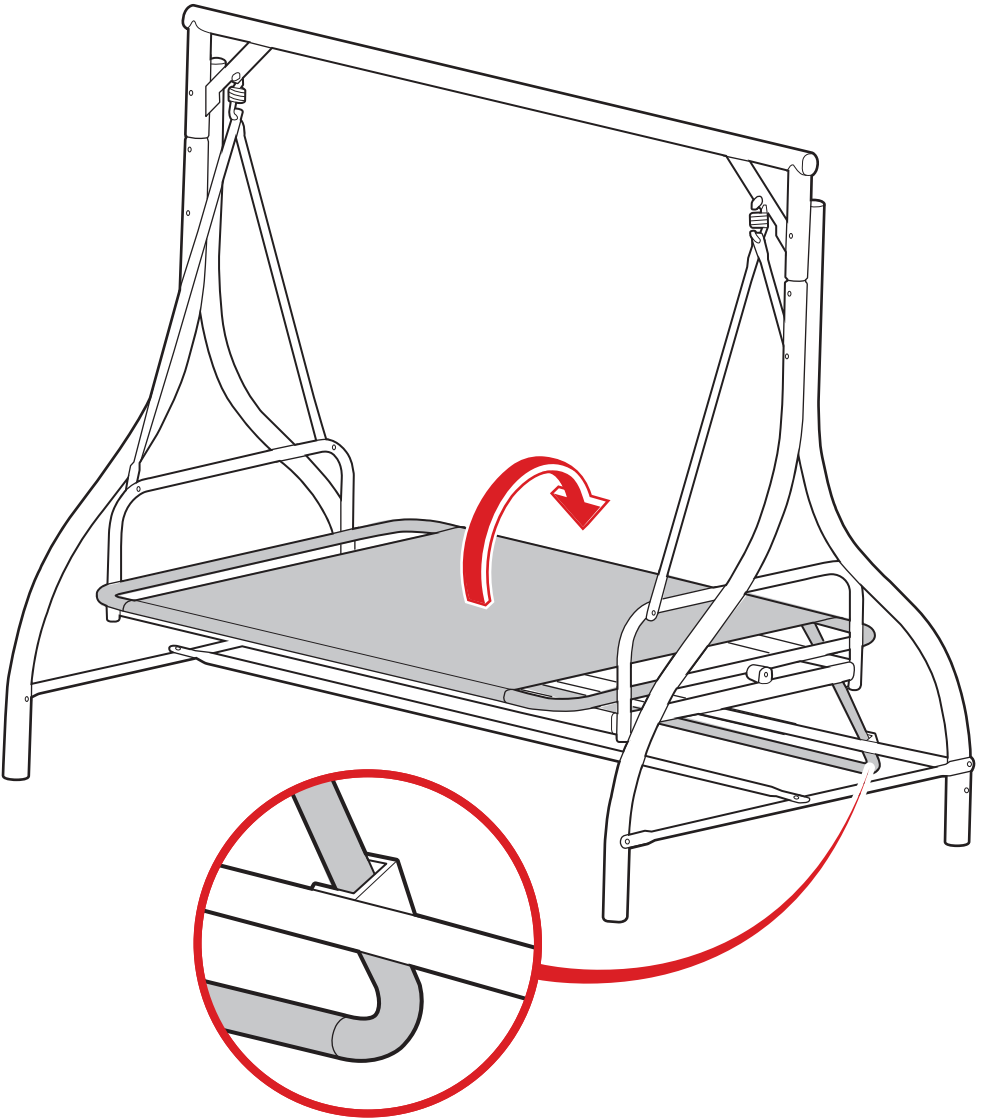

PRODUCT WARRANTY INFORMATION

All items can be returned for any reason within 60 days of the receipt and will receive a full refund as long as the item is returned in its original product packaging and all accessories from its original shipment are included. All returned items will receive a full refund back to the original payment method. All returned items will not be charged a re-stocking fee.

All returned items require an RA (Return Authorization) number, which can only be provided by a Best Choice Products Customer Service Representative when the return request is submitted. Items received without an RA may not be accepted or may increase your return processing time. Once an item has been received by Best Choice Products, refunds or replacements will be processed within 5 business days.

All returns must be shipped back to the Best Choice Products Return Center at the customer's expense. If the reason for return is a result of an error by Best Choice Products then Best Choice Products will provide a pre-paid shipping label via email. Boxes for return shipping will not be provided by Best Choice Products, and is the customer's responsibility to either use the original shipping boxes or purchase new boxes.

Pictures may be required for some returns to ensure an item is not damaged prior to its return. Items returned are not considered undamaged until they are received by Best Choice Products and verified as such. All damages to items are the customer's responsibility until the item has been received by and acknowledge by Best Choice Products as undamaged.

WARNING

Manufacturer and seller expressly disclaim any and all liability for personal injury, property damage or loss, whether direct, indirect, or incidental, resulting from the incorrect attachment, improper use, inadequate maintenance, unapproved modification, or neglect of this product.