

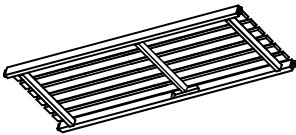
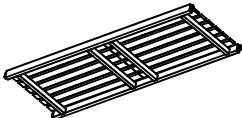
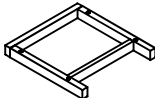

Part List

| PIECE | DESCRIPTION | PICTURE | QUANTITY |
|-------|-------------|---|----------|
| A | Seat |  | 1x |
| B | Tray |  | 1x |
| C | Side part |  | 2x |

Hardware List

| PIECE | DESCRIPTION | PICTURE | QUANTITY |
|-------|-------------|--|----------|
| HW1 | Allen screw |  M6x80 | 8x |
| HW2 | Allen Key |  | 1x |

Installation & Assembly

Product Dimension: 50.79" L x 16.14"D x 17.32"H

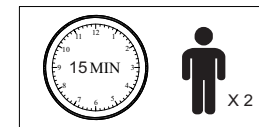
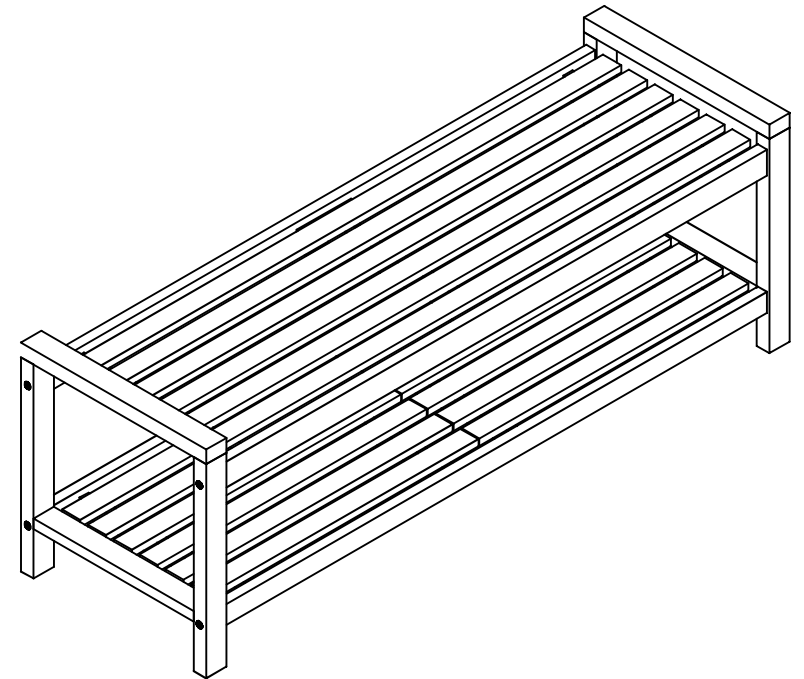

WEIGHT CAPACITY: 275 LBS PER SEATING
WARNING: DO NOT STAND ON CHAIR

PREPARATION

Tool required for assembly (included): Allen Key.

1

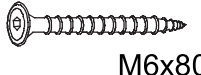
| | | |
|-----|---|----|
| HW1 |  | 4x |
|-----|---|----|

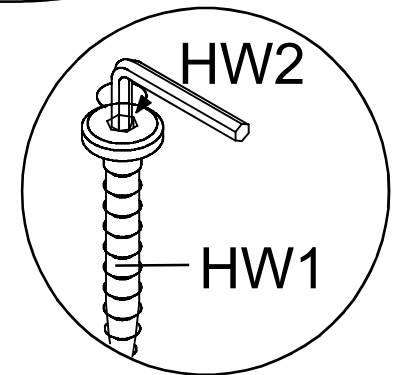
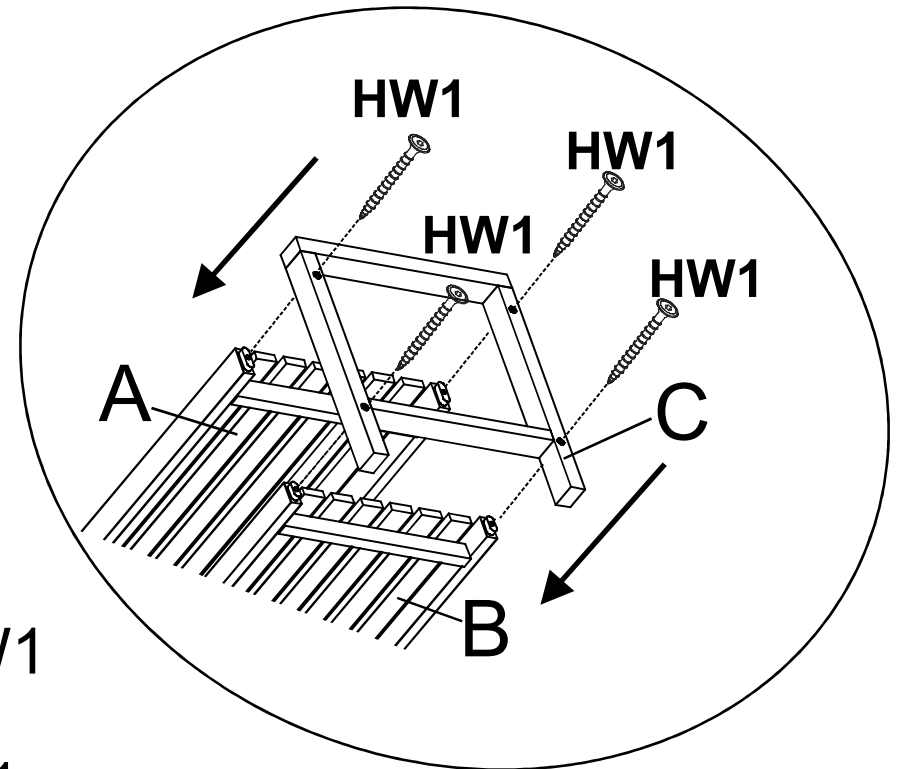
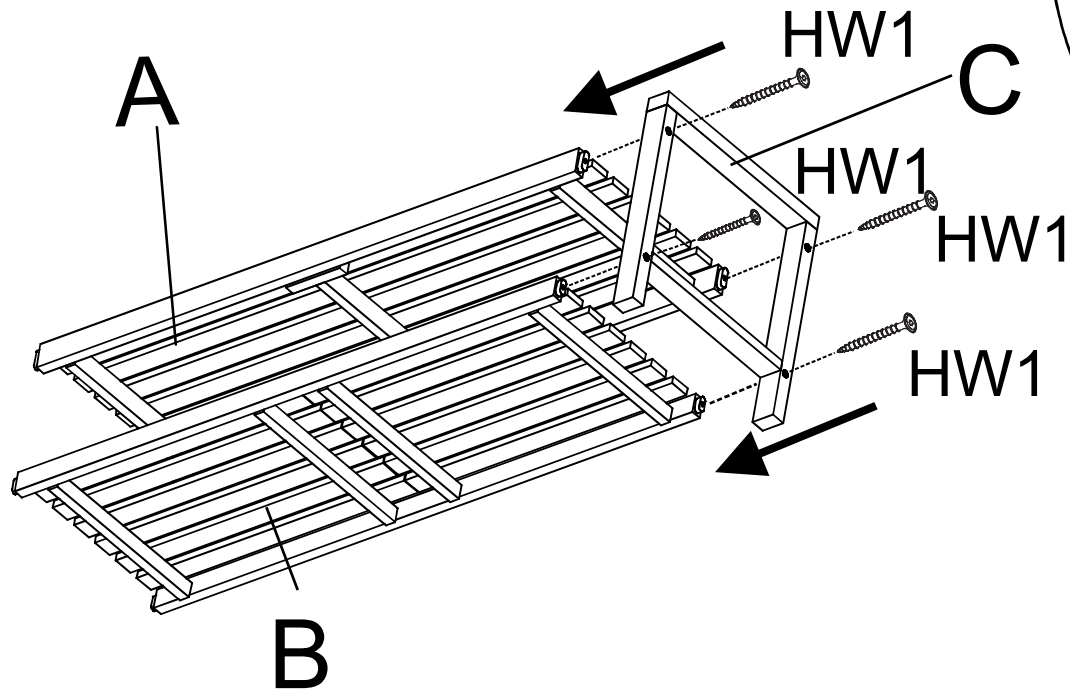

Step 1: Attach the Side (C) to the Seat (A) and the Tray (B) as shown on the picture .Using the Allen screw (HW1) to fix the Side (C) to the Seat (A) , the Tray (B) by the Allen key (HW2) .

PREPARATION

Tool required for assembly (included): Allen Key.

2

HW1



4x

M6x80

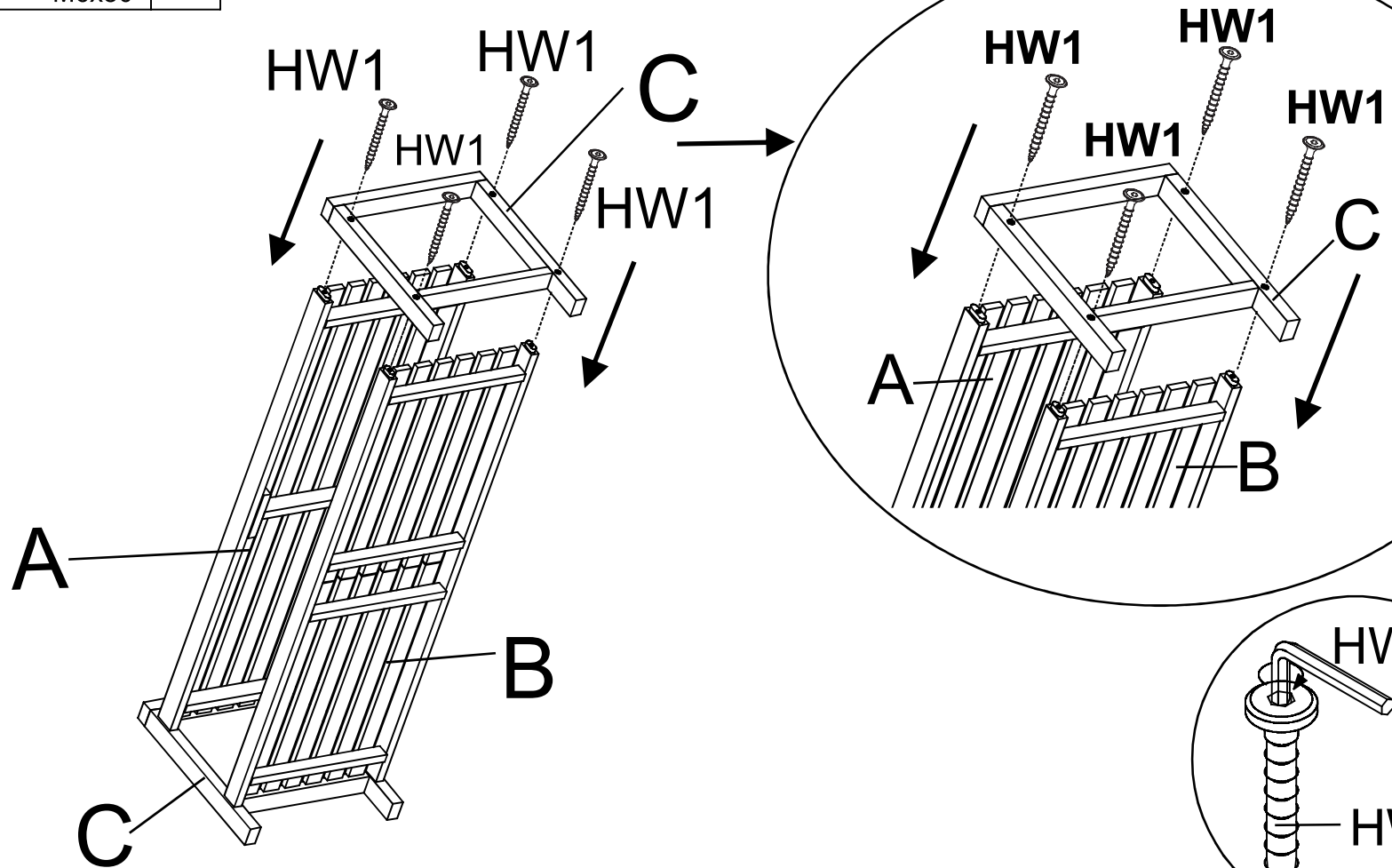

Step 2: Attach the Side (C) to the Seat (A) and the Tray (B) as shown on the picture .Using the Allen screw (HW1) to fix the Side (C) to the Seat (A) , the Tray (B) by the Allen key (HW2) .