

Tall Planter Instructions



Made in USA

PACKAGE CONTENTS: 1x Tall Planter, 1x Removable Tray Insert

MATERIAL: Linear low-density polyethylene (LLDPE)

WARRANTY: 15-year residential warranty

IMPORTANT NOTE:

- **DRAINAGE HOLES ARE NOT INCLUDED** but can be easily drilled in the desired location depending on the intended use of the planter. See instructions on the reverse side for more details.
- Do not overload the patio planters. **Lightweight fillers and potting mixes** are recommended and yield better plant growth.
- Suitable for flowers, herbs, vegetables, and small plants.

General Information:

- Read instructions carefully before beginning assembly.
- To clean the product use a soap solution and high-pressure water.
- The molded polyethylene construction is designed to withstand cold temperatures but you may wish to winter store the planter in a shed or garage to offer the best protection from extreme cold.

Product Dimensions

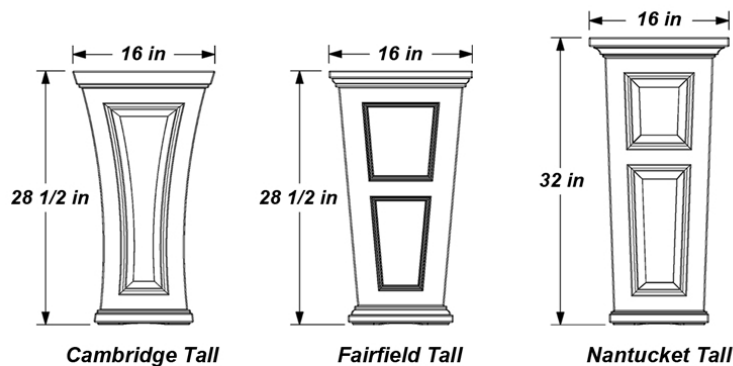

Cross Section (typical for all 3 planters)

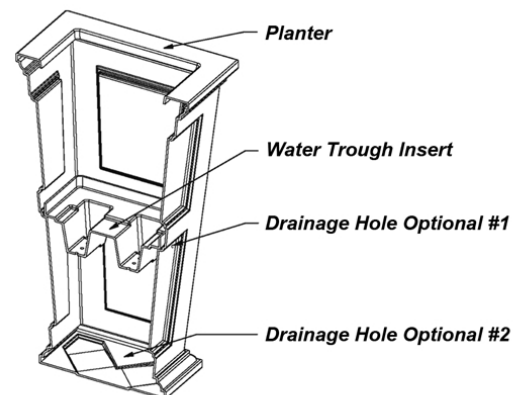

Removable Tray Insert

To remove the tray, push down firmly on one corner and lift up on the opposite corner. Due to the variations in the molding process the tray might be a tight fit. If this is the case a little extra force may be required to pop the tray out.

Note: The tray can also be flipped upside down to create a raised platform for a potted plant. To re-insert the tray, tilt it on a slight angle and wedge it back into the center of the planter. Similar to the removal, a little extra force may be needed to drop the tray back into position.

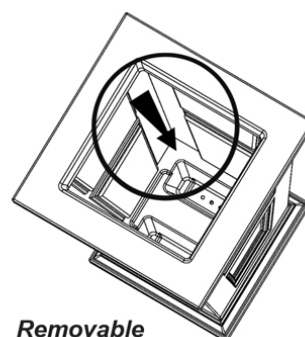

Removable
Tray Insert

Planting Instructions

Drainage Option #1:

To utilize the water trough system, drill a hole in the side of the planter as shown on the right (location varies for each planter style). The overflow hole will maintain the ideal amount of water to keep the plant roots moist and avoid over saturation of the soil. Additional drainage holes are recommended for areas that receive heavy rainfall.

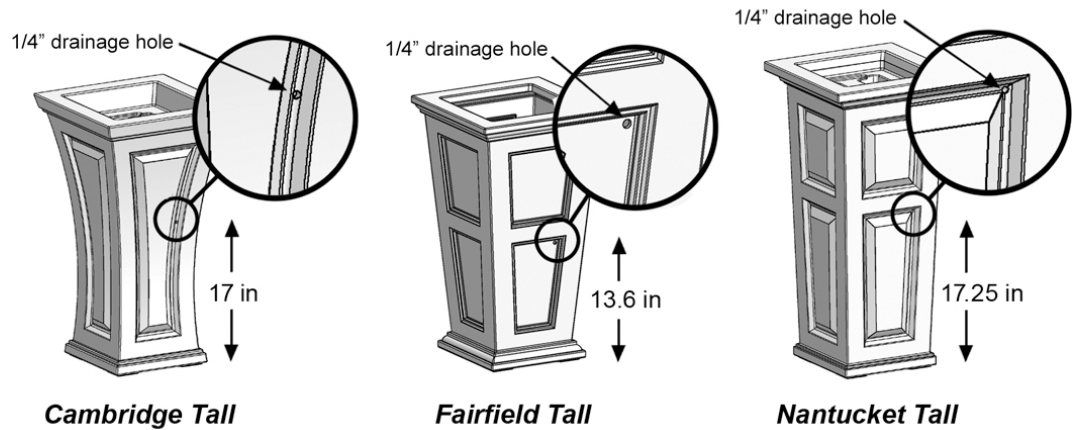

Drainage Option #2:

To use the planter as a regular container planter simply drill two holes in the bottom to allow for proper drainage. The insert tray is completely optional and can be removed if it's not needed. If the tray is removed, we recommend filling the bottom half of the planter with a light weight filler to ensure proper drainage.

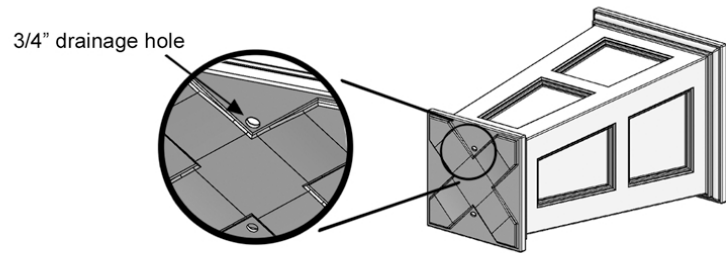

General Planting Recommendations:

To maximize the efficiency of the sub-irrigation system and encourage healthy plant growth we recommend the following:

- 1) Make sure the tray insert is securely in place before proceeding with setup.
- 2) Next, add a couple inches of lightweight filler to the bottom of the planter. This is optional but reduces the amount of potting mix required. Some examples include wood chips, lava rock, foam packing peanuts, or crushed water bottles.
- 3) Top up the planter with a potting mix. Do not use garden soil, it won't allow for proper aeration or drainage.
- 4) Start planting and enjoy!

Sub-Irrigation System

The Tall Planter Collection includes a water trough insert that creates a sub-irrigation water reservoir at the bottom of the planter. Capillary action allows water in the reservoir to soak upward keeping the soil and plant roots moist. To avoid over saturation an overflow hole is drilled through the outside wall allowing excess water to drain out from the planter. Regular watering is required for the first few weeks giving the root system time to develop. Please note that due to the height of these planters, the root system on some plants may not fully reach the water trough so regular watering may be required for a longer period of time.

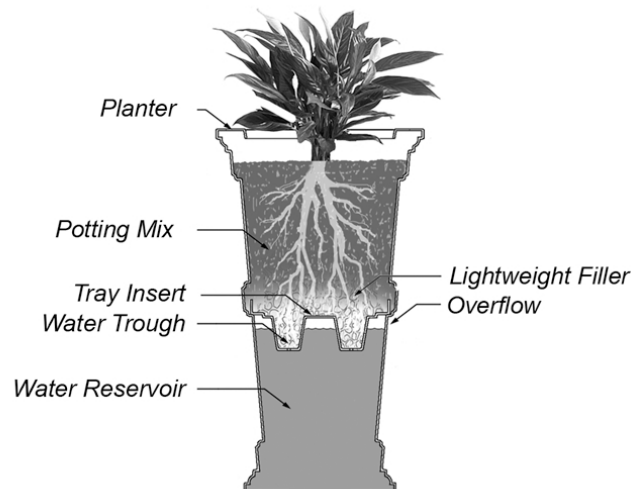

NOTE: The information above is only suggested and Mayne holds no liability for the condition or growth of your plants.