

ASSEMBLY INSTRUCTION

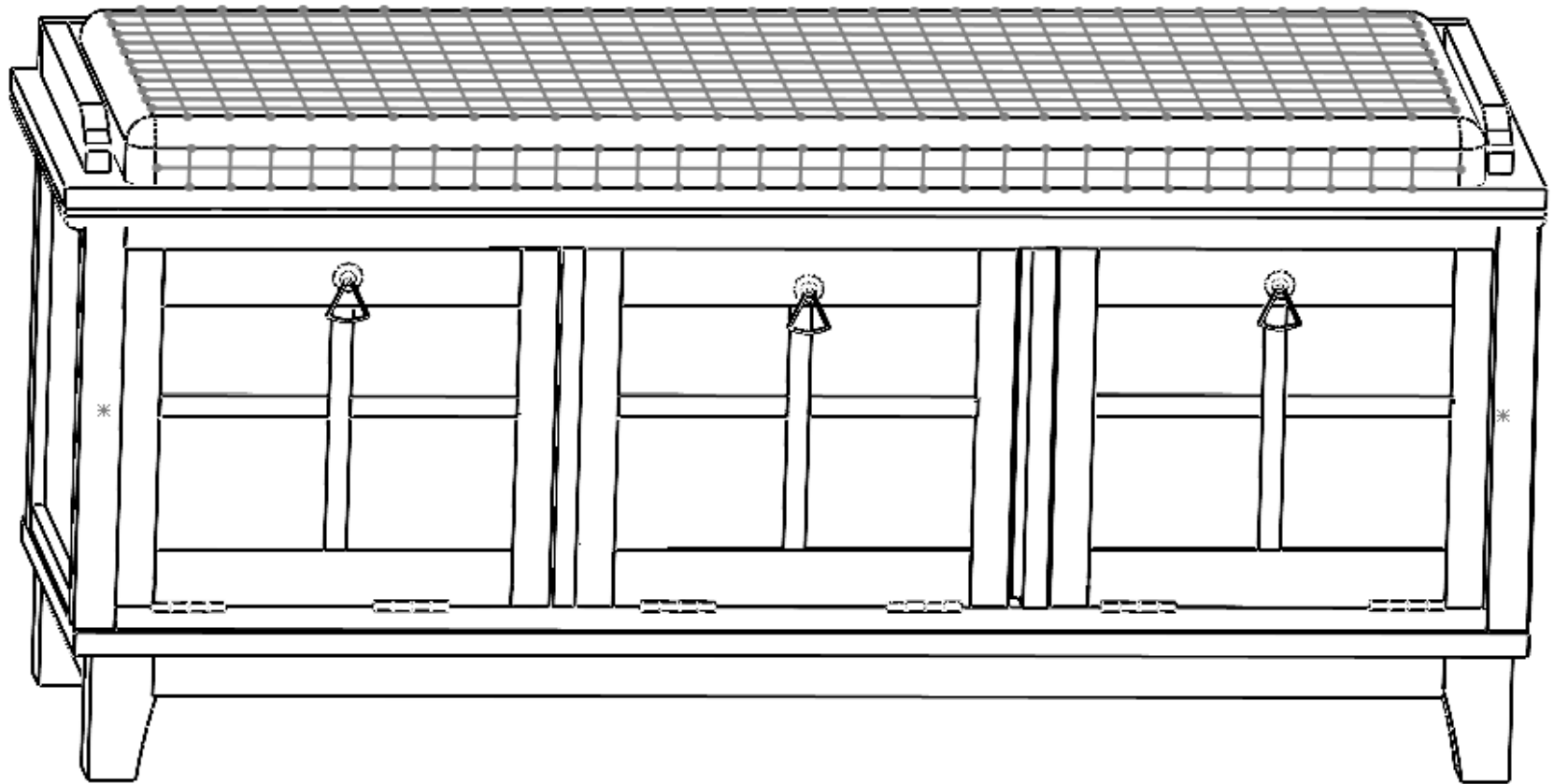

PART LIST

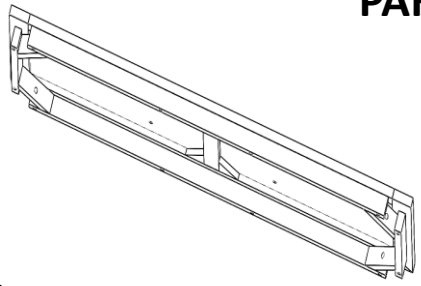

- (A)** Bottom component
Quantity: 1 pc

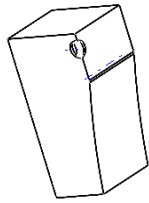

- (B)** Legs
Quantity: 4 pcs

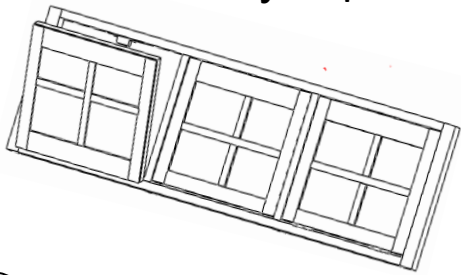

- (C)** Front Component
Quantity: 1 pc

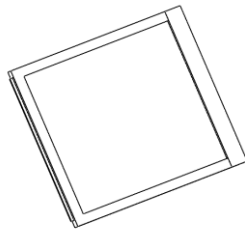

- (D)** Side component
Quantity: 2 pc

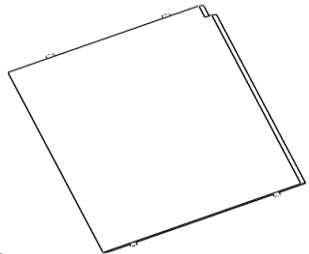

- (E)** Divide
Quantity: 2 pc

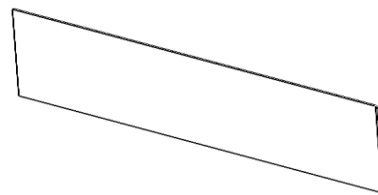

- (F)** Back panel
Quantity: 1 pc

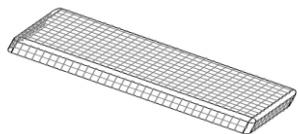

- (G)** Cushion on top
Quantity: 1 pc

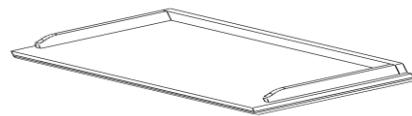

- (H)** Top component
Quantity: 1 pc

HARDWARE LIST



- (1)** 6x40 mm
Quantity: 4 pcs



- (2)** 6x16 mm
Quantity: 20 pcs



- (3)** 4x20 mm
Quantity: 3 pcs





- (4)** Quantity : 3 pcs



- (5)** 6x25 mm
Quantity: 16 pcs



- (6)** Quantity : 1 pc

① 	② 	⑥ 
Quantity : 4 pcs	Quantity : 4 pcs	Quantity : 1 pc

STEP 1

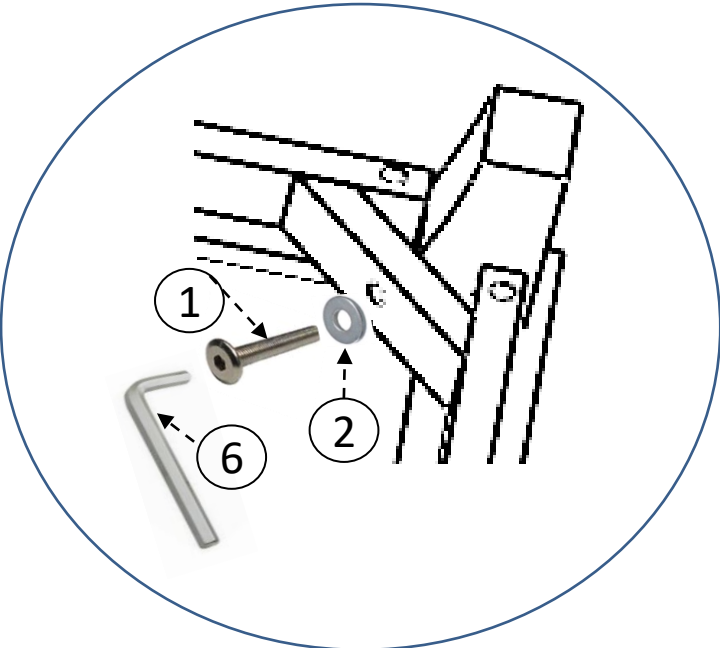

DETAIL X

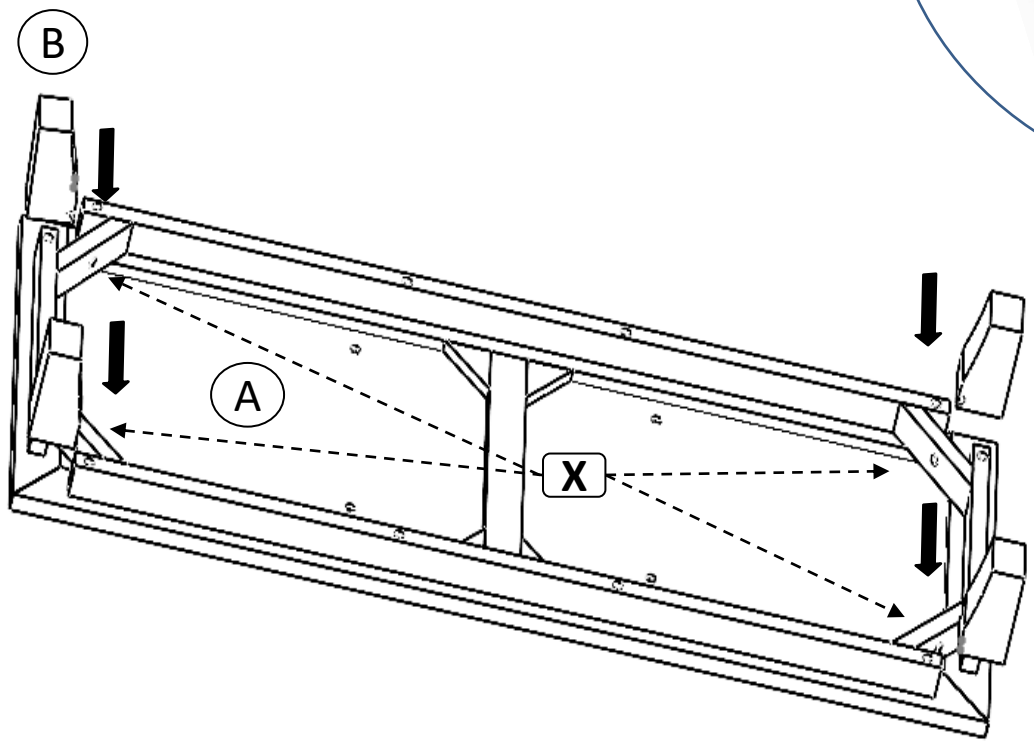

5



2





STEP 2

Quantity : 3 pcs

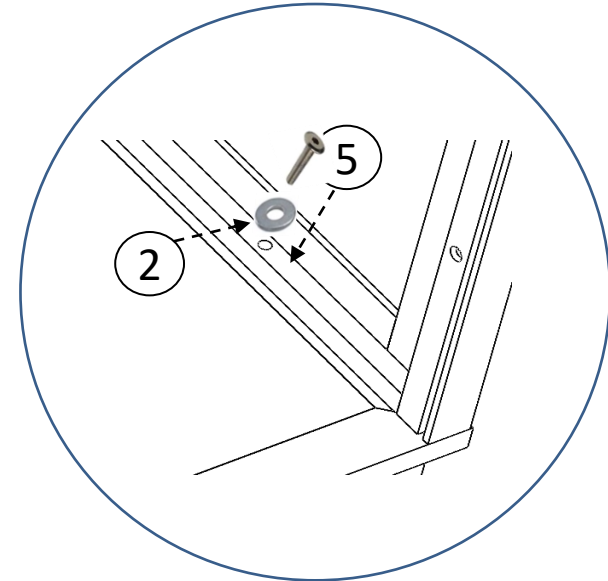
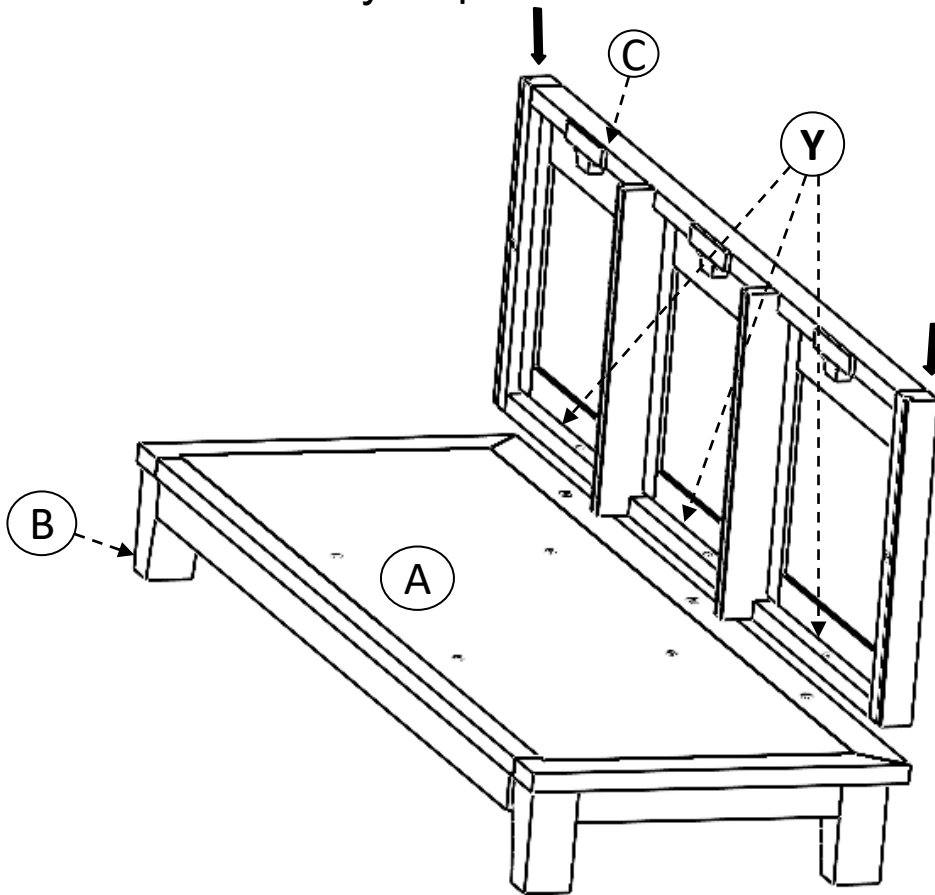
Quantity : 3 pcs



DETAIL Y

<p>⑤ </p>	<p>② </p>
<p>Quantity : 6 pcs</p>	<p>Quantity : 6 pcs</p>

STEP 3

STEP 4

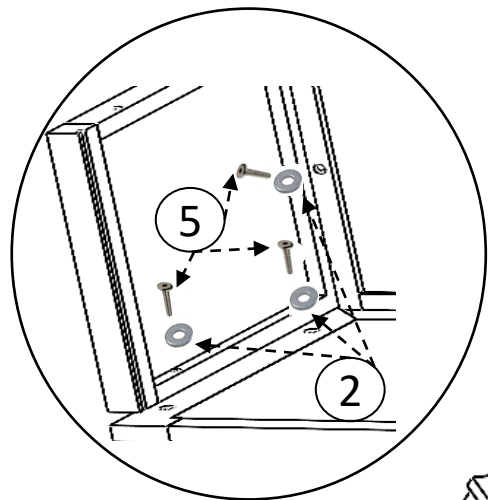

DETAIL Z

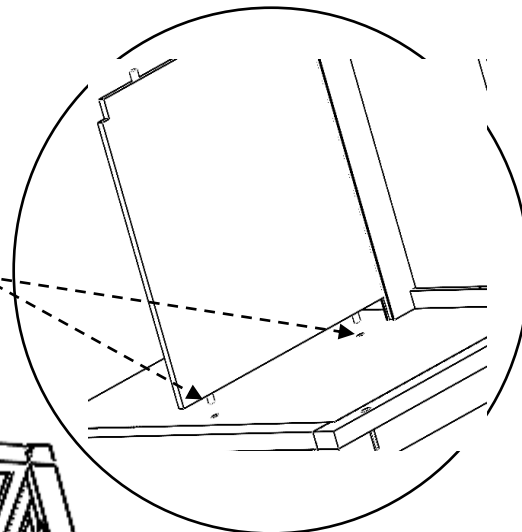
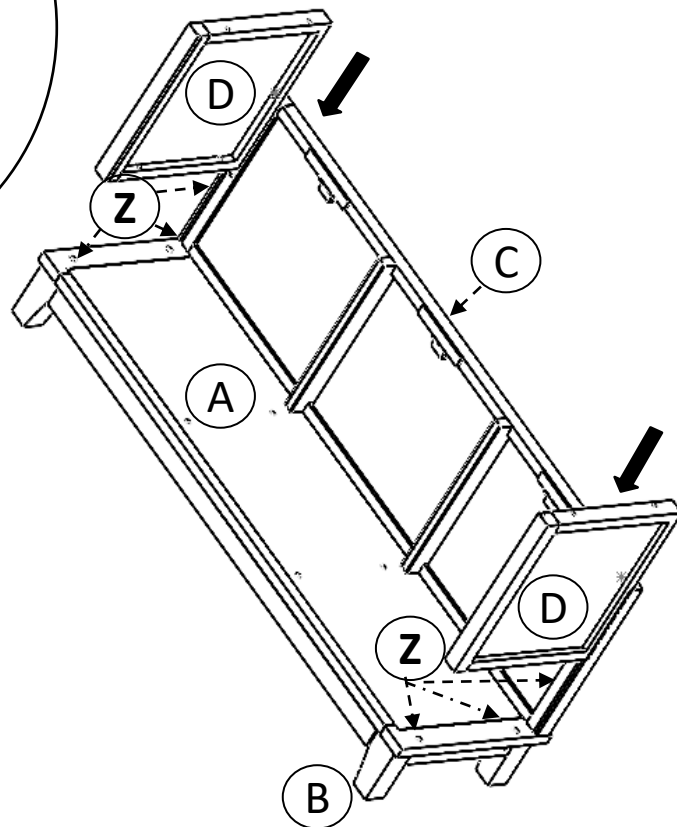

DETAIL M

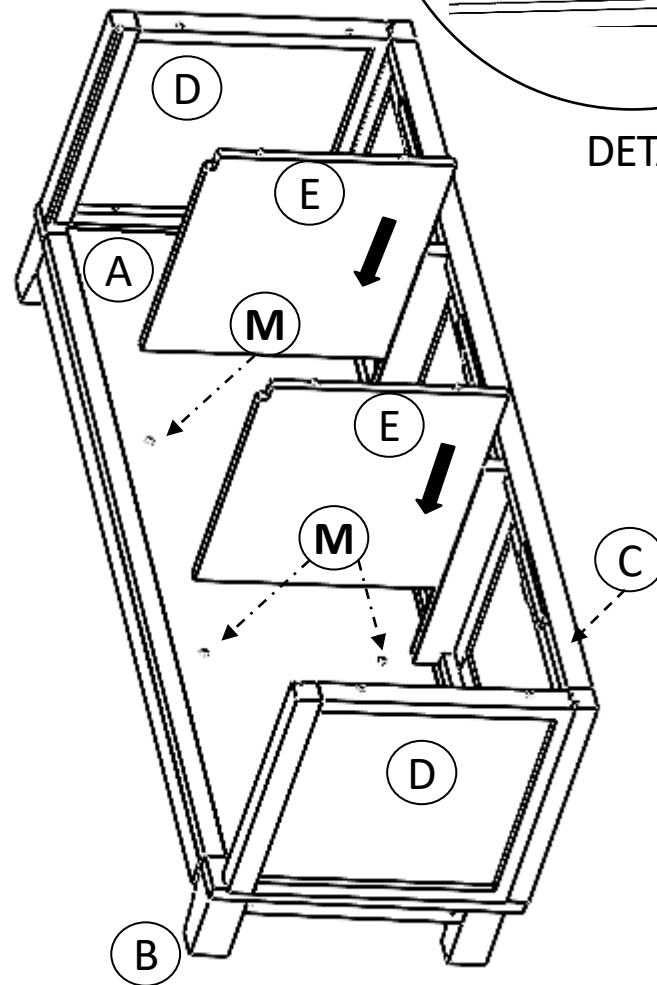

STEP 5

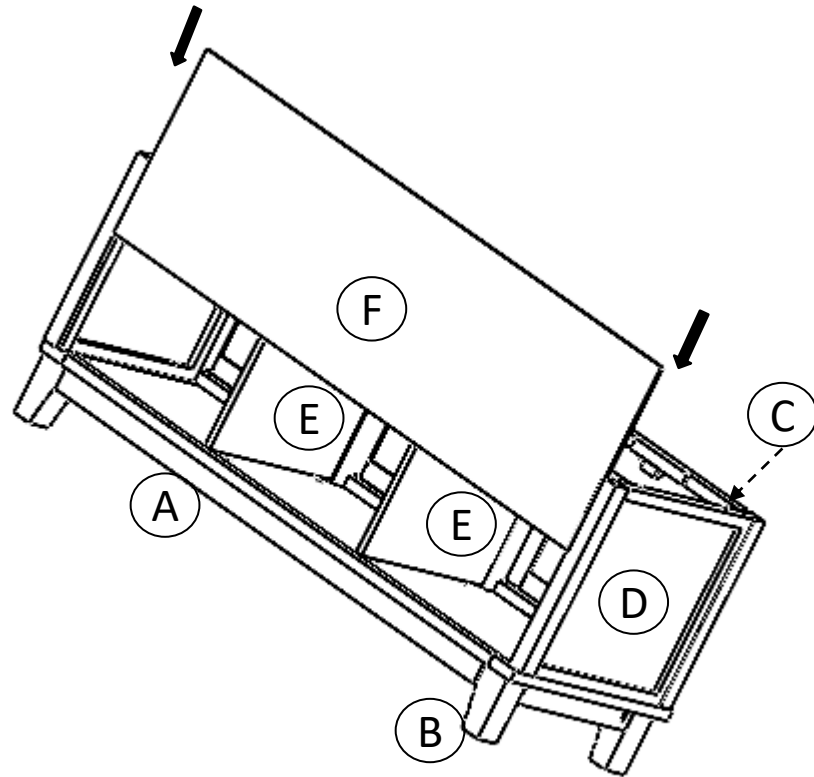

STEP 6

DETAIL N

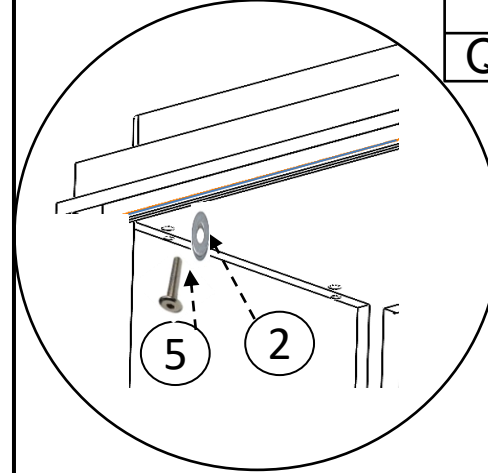

5



Quantity : 7 pcs

2



Quantity : 7 pcs

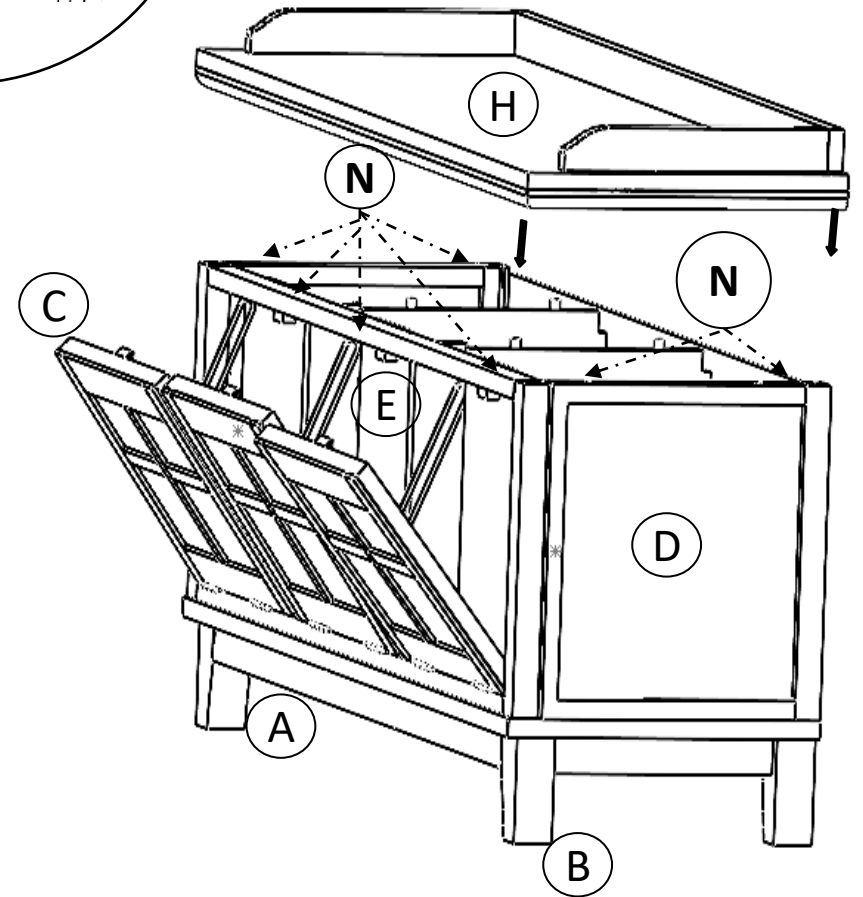

STEP 7

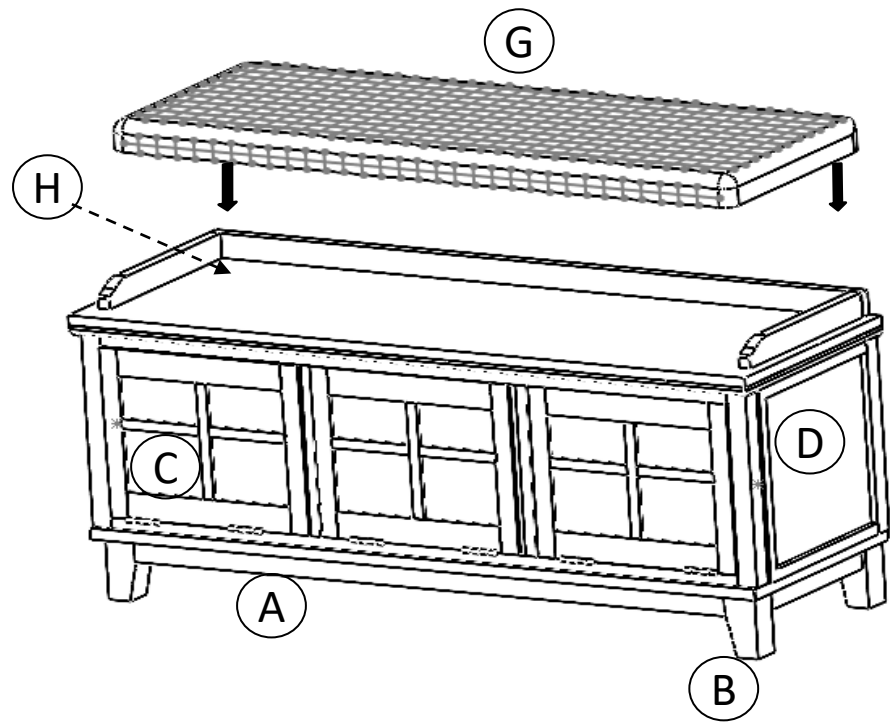

3



Quantity : 3 pcs

4



Quantity : 3 pcs

STEP 8

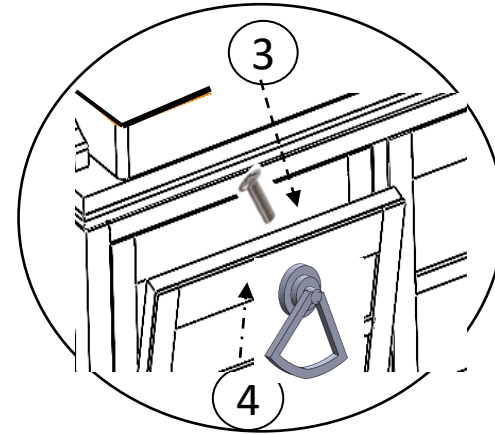

DETAIL P

