

# Installation Instruction

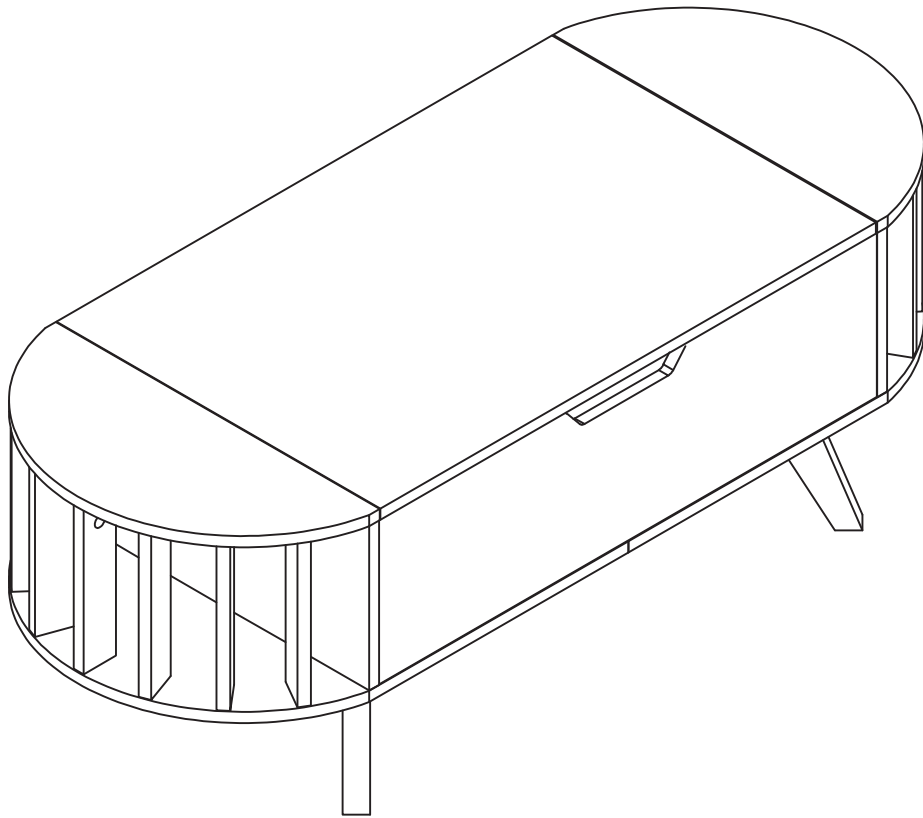

# Assembling

Estimated time for assembly



**45 : 00**

## What you need

- Use the packaging carton as a working surface to prevent product damage during assembly
- Phillips head screwdriver

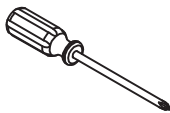

## Weight Limitation



**100** | **35**  
lbs table top    lbs per

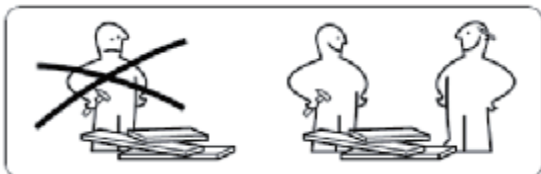

# What' included

Code	Description	Qty
A	Cam Bolt M6X35MM	16
B	Cam Lock 15X12MM	16
C	Wooden Dowel M8X30MM	38
D	Screw M4X40MM	30
E	Screw M3.5X14MM	20
F	Left regulator	1
G	Right regulator	1
H	Screw M7X40MM	4
I	screw M4X55MMr	1
J	Foot nail	4
K	Gasket	4
L	sticker	14

# The Hardwares

(A)

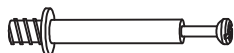

(B)



(C)



(D)



(E)



(F)

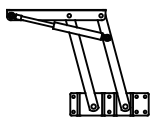

(G)

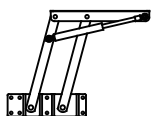

(H)

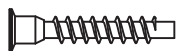

(I)



(J)



(K)



(L)



## IMPORTANT:

1. Do not tighten bolts / screws completely until all bolts / screws are lined up and inserted into holes.
2. Do not over tighten screws and bolts to avoid stripping
3. Please use hand tools to assemble this product. Do not use power tools.

# Included Accessories

---

<b>Code</b>	<b>Description</b>	<b>Qty</b>
1	Intermediate panel	1
2	Left and right panels	2
3	Left side plate	1
4	Right-side plate	1
5	Left bottom plate	1
6	Right bottom plate	1
7	Support plate	2
8	Swivel plate	12
9	Supporting foot	4
10	Backboard	1
11	Front apron	1

# The Accessoriss

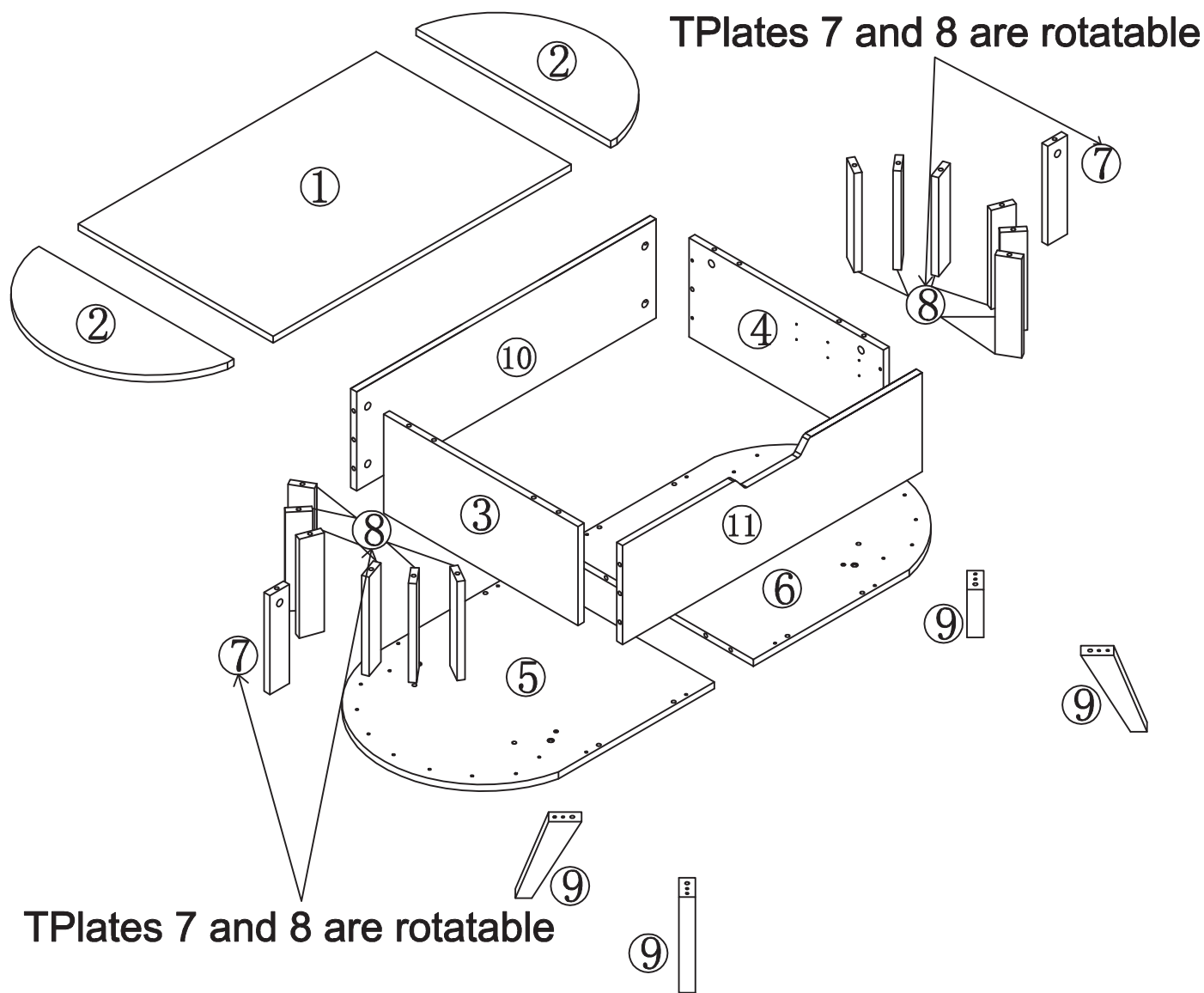

# Step 1

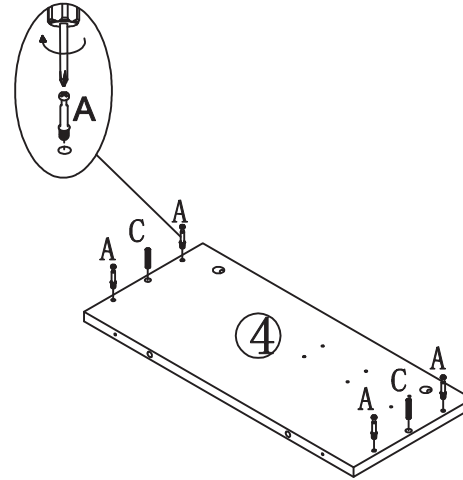
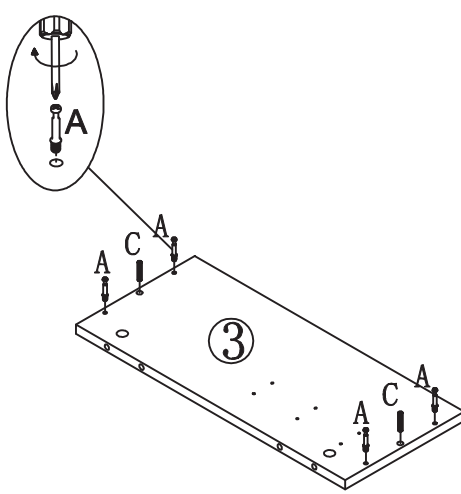
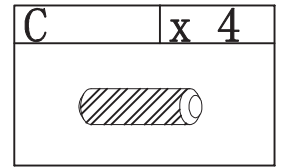
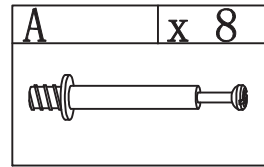

# Step 2

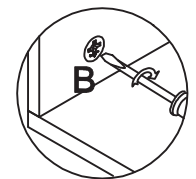
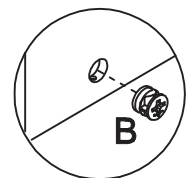
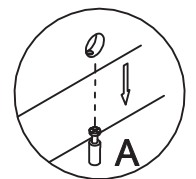
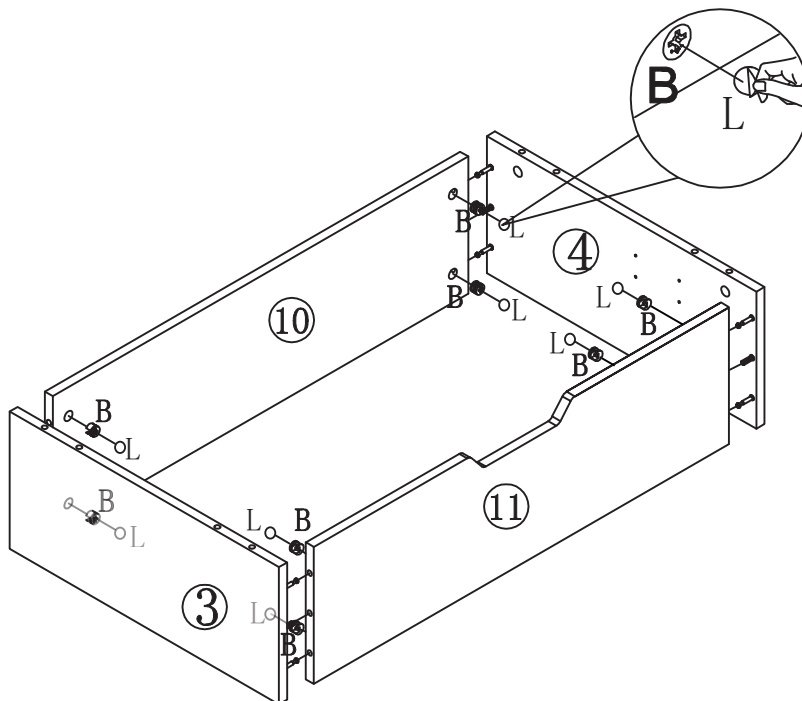
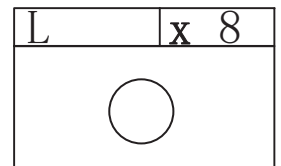
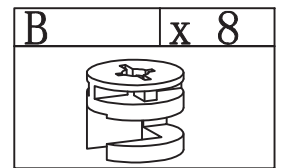

# Step 3

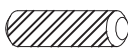
C	x 12
	

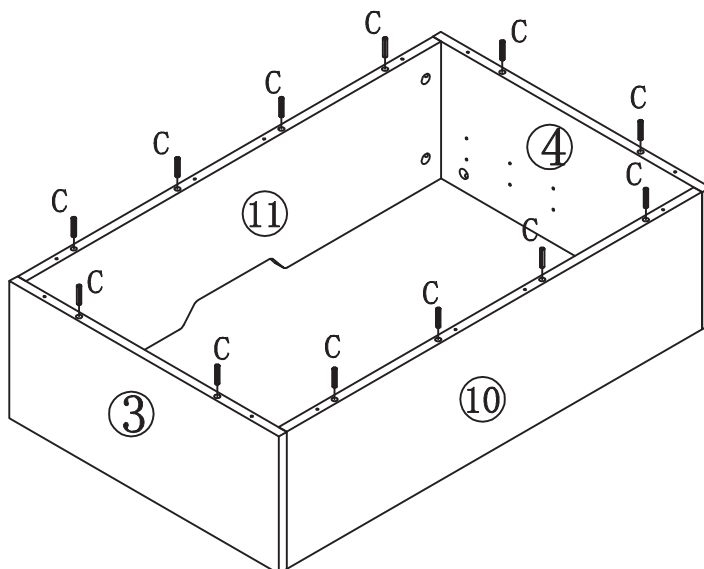

# Step 4

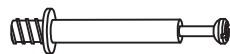
A	x 8
	

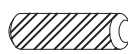
C	x 2
	

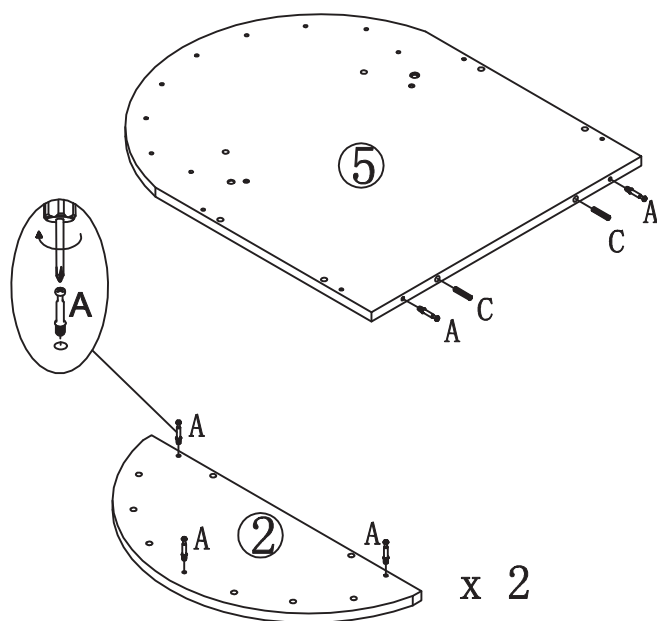

# Step 5

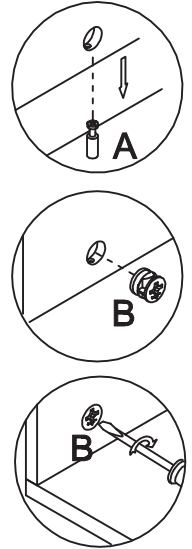
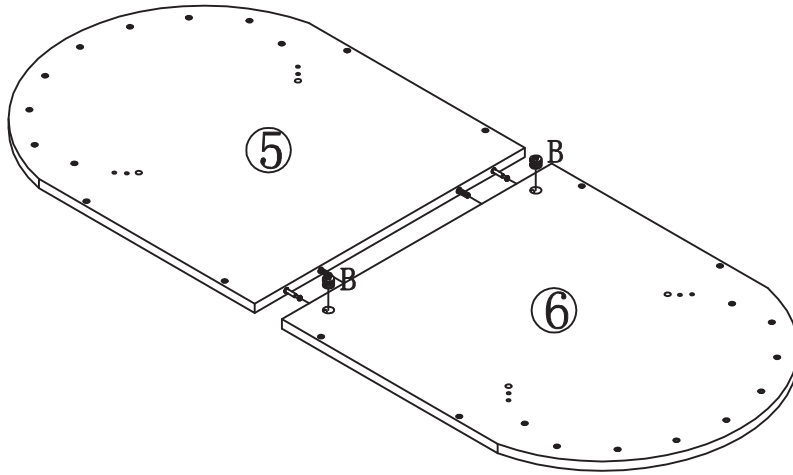
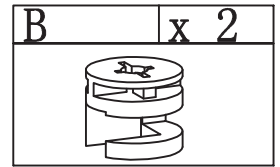

# Step 6

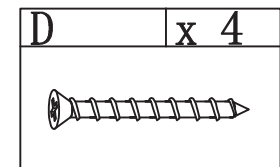
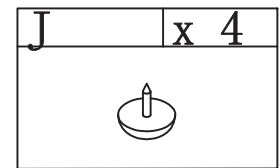
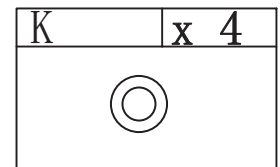
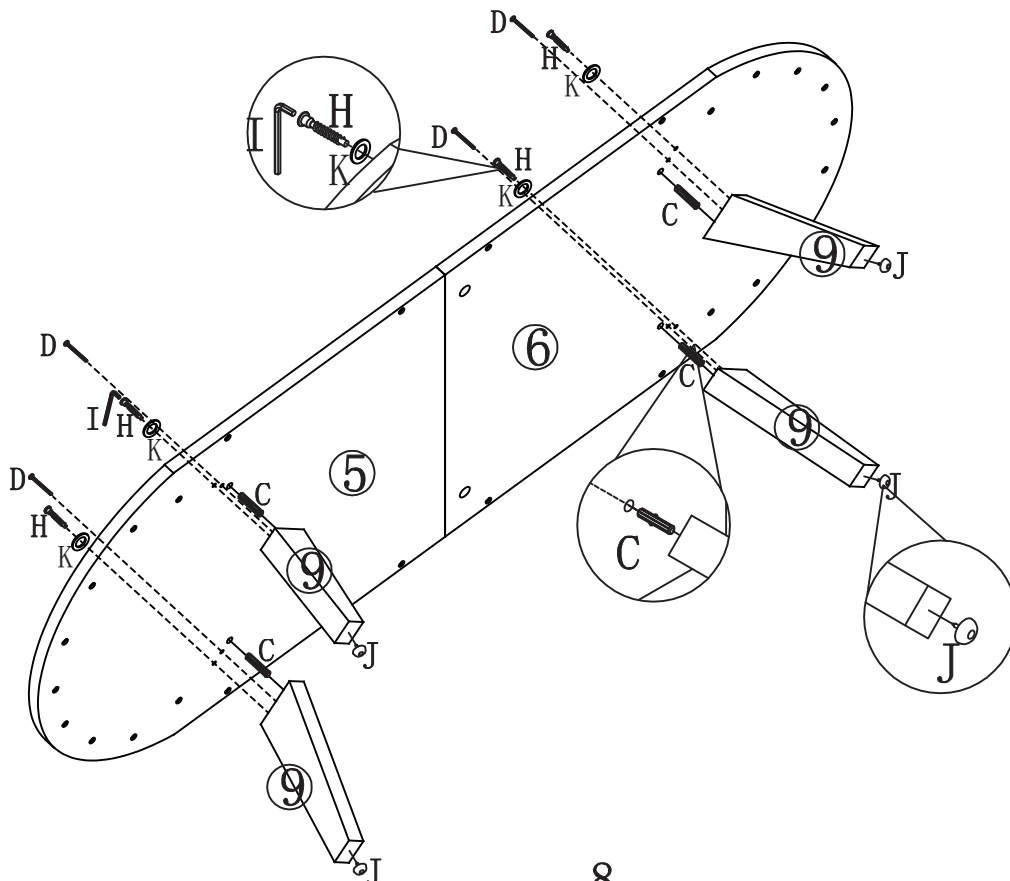
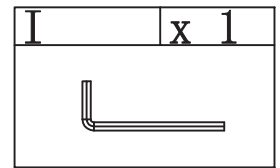
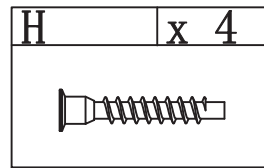
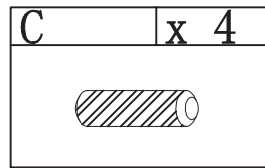

# Step 7

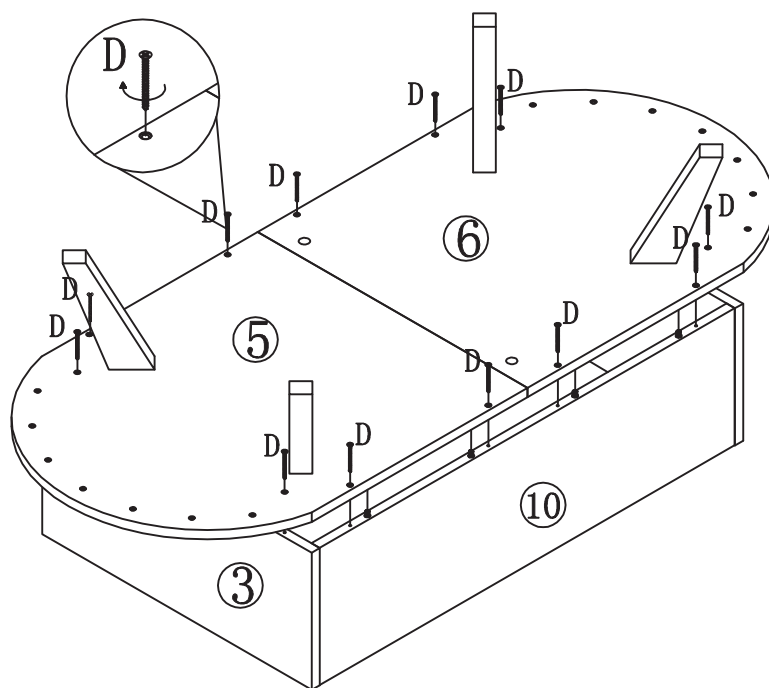
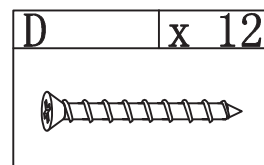

# Step 8

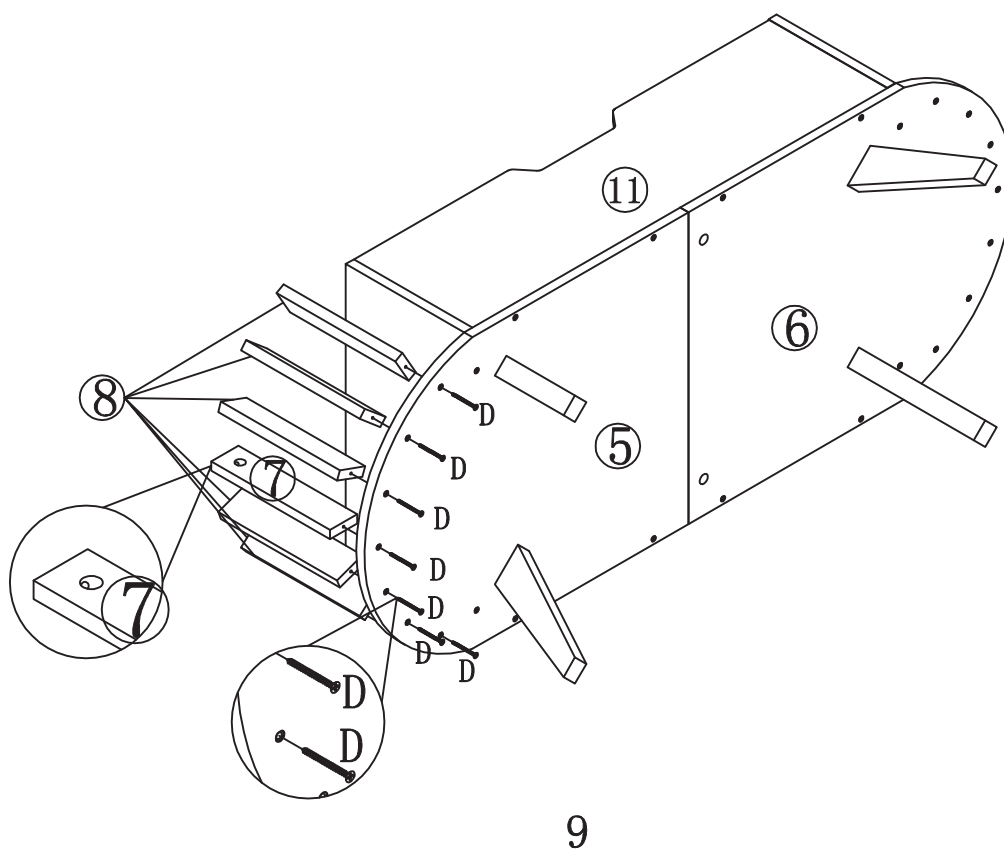
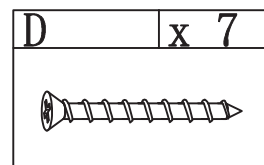

# Step 9

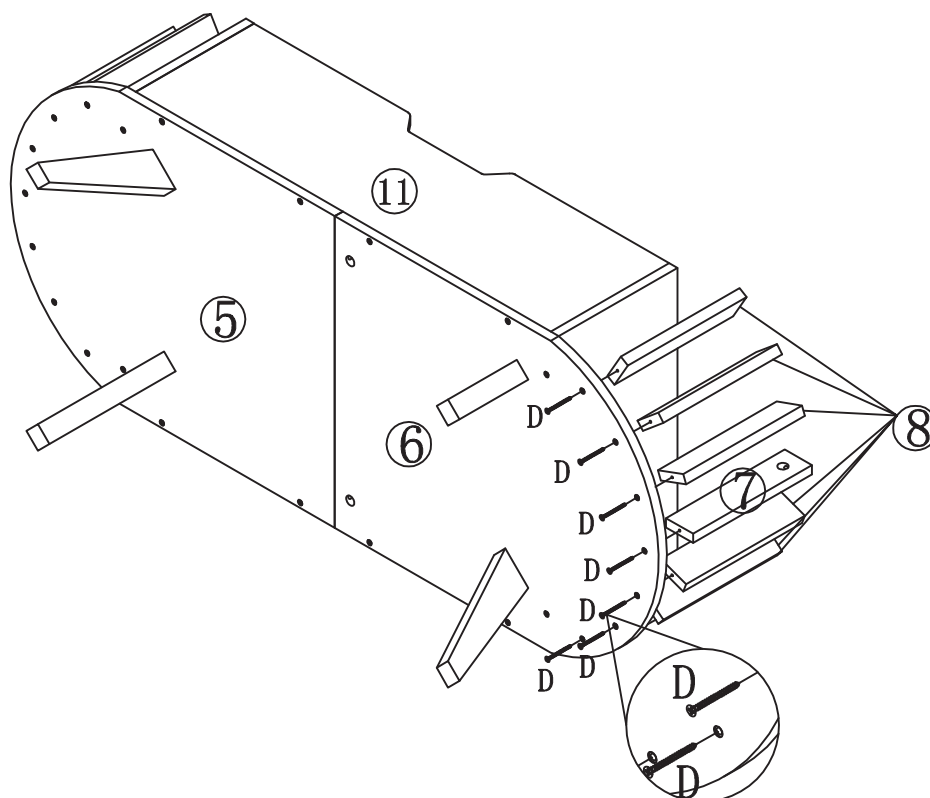
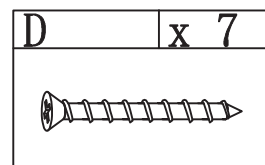

# Step 10

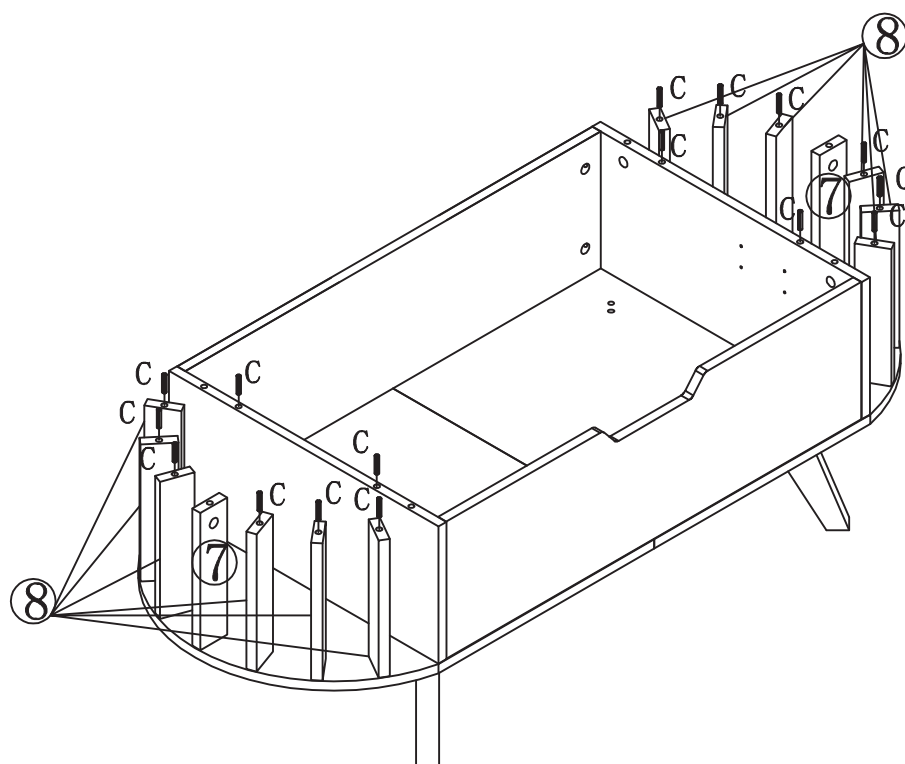
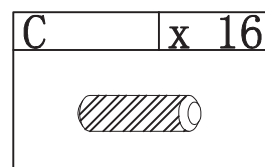

# Step 11

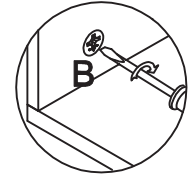
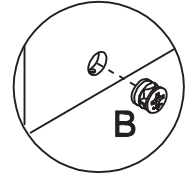
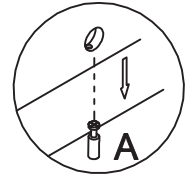
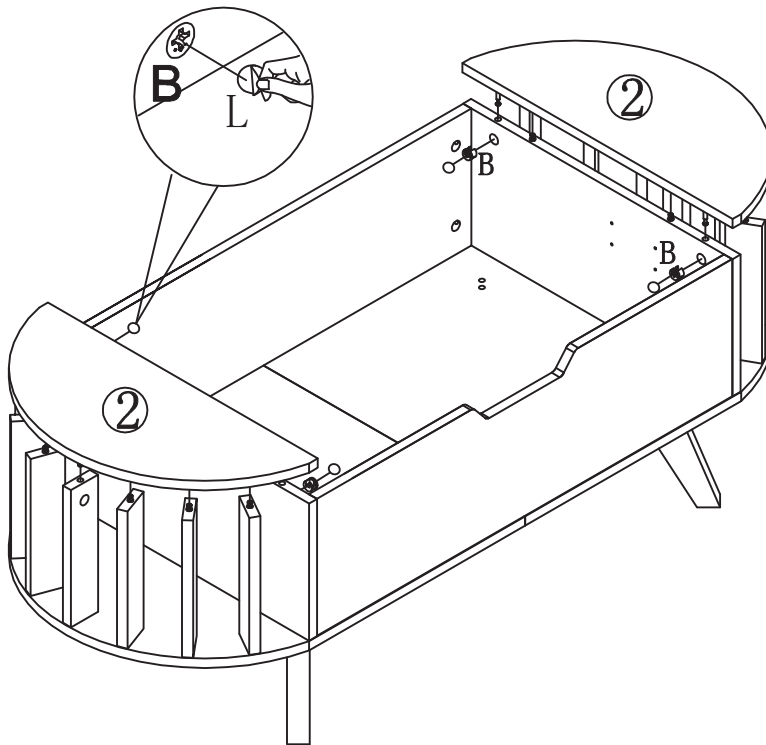
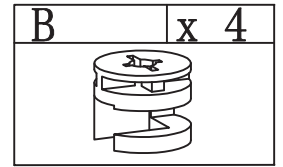
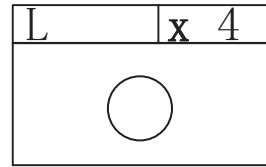

# Step 12

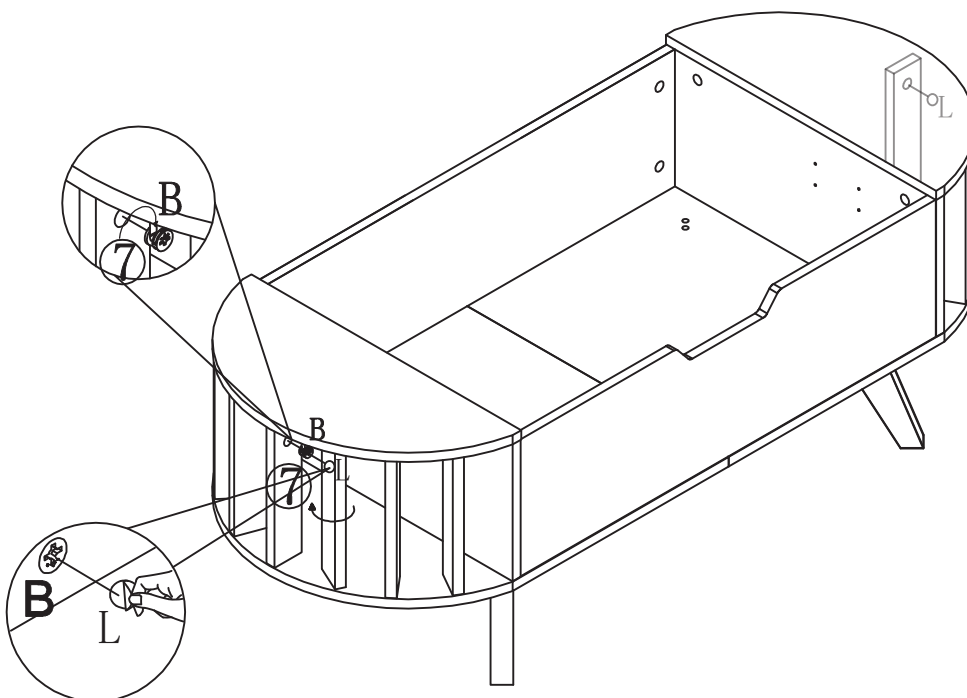
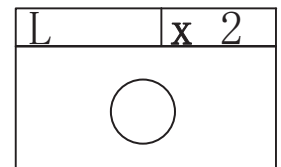
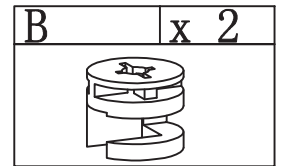

# Step 13

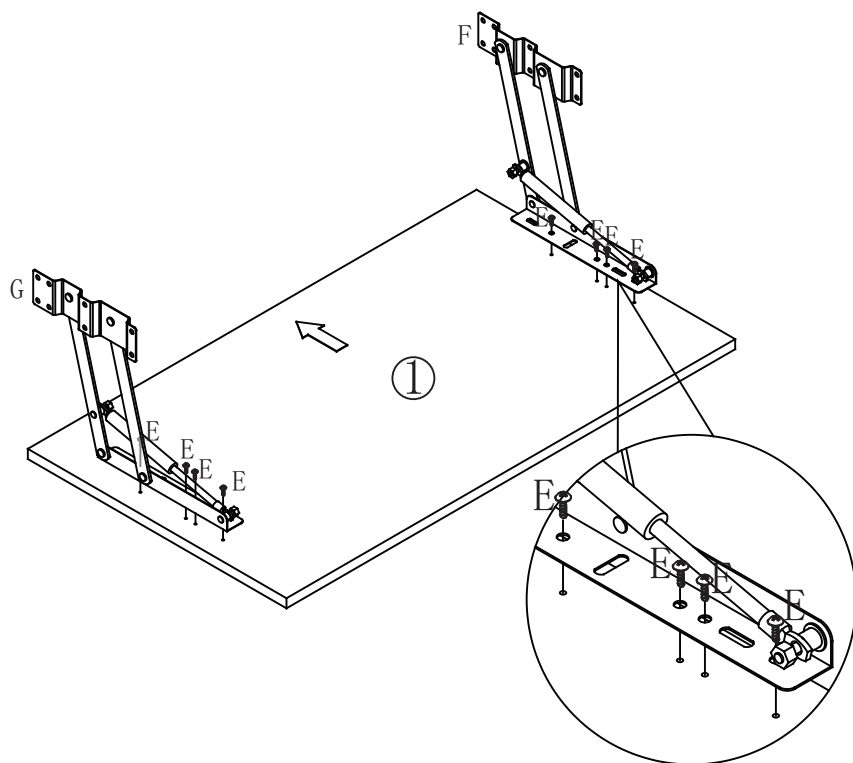

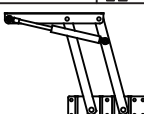

E	x 8
	

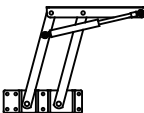
F	x 1
	

G	x 1
	

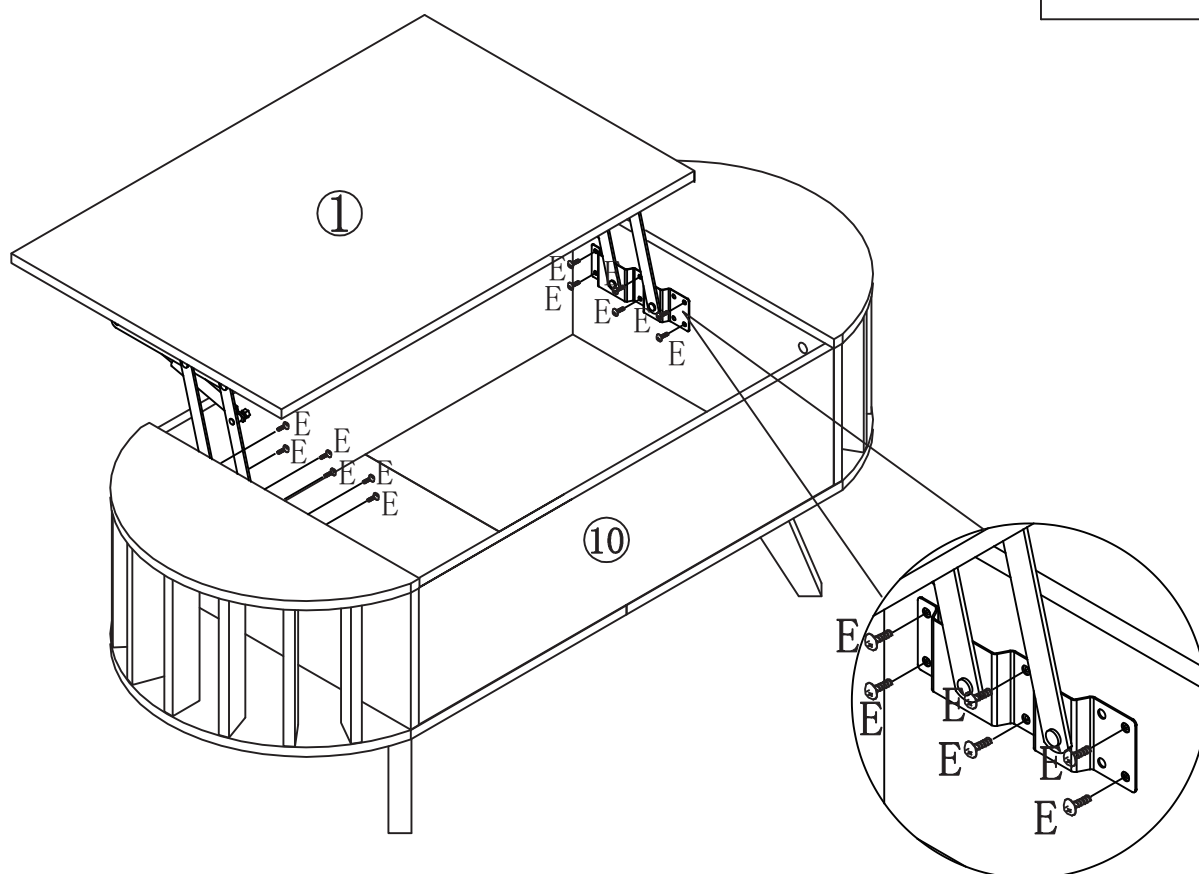
# Step 14



E	x 12
	

# Step 15

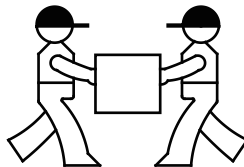
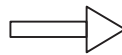
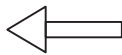
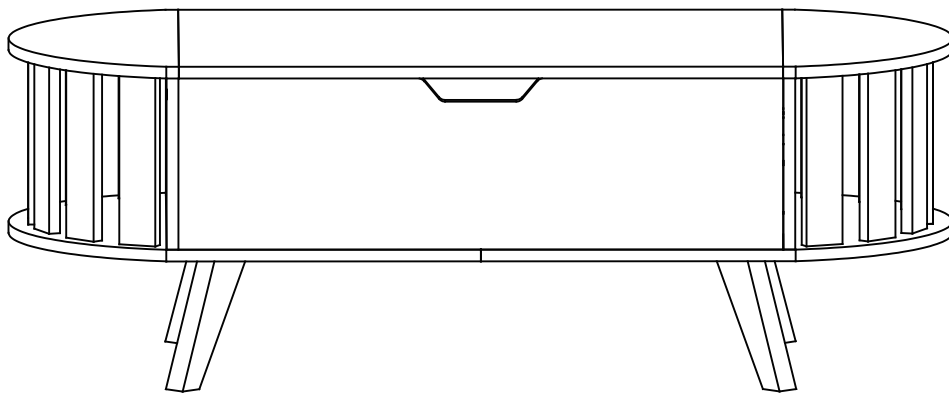
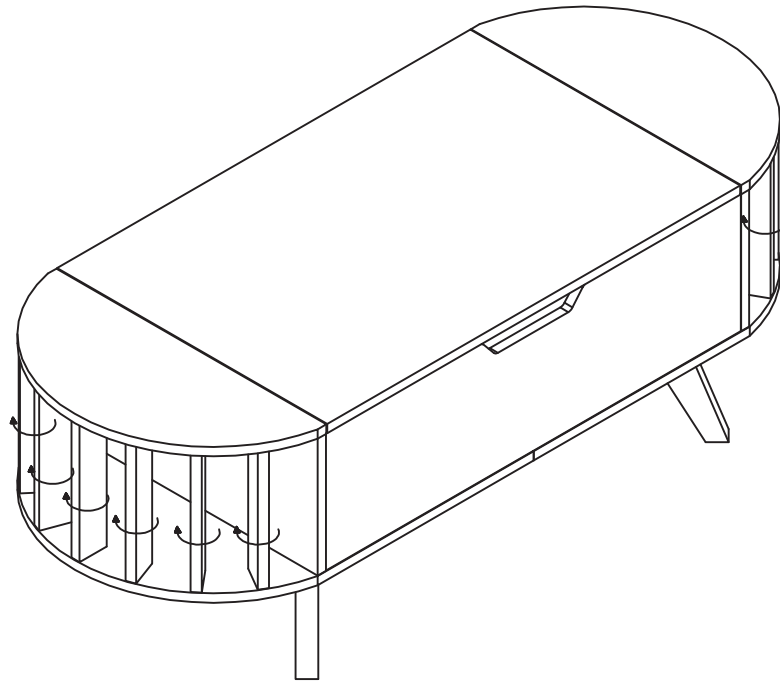

Two people work together to move the table.  
Make sure you lift it off the ground.  
Don't push and pull.