

Aluminium Sofa Set

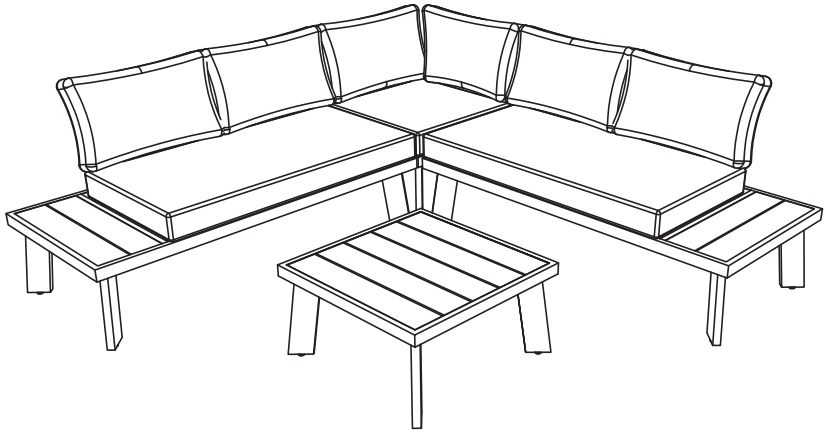



**IMPORTANT, RETAIN FOR
FUTURE REFERENCE:
READ CAREFULLY.**

Safety

- For domestic use only.
- Always use on firm level ground.
- Don't tighten all the bolts before the product is fully assembled.
- It would be useful to ask someone to help you assemble the product.
- Periodic structural checks of this product should be undertaken, do not use if you have any doubts about its fitness for purpose.
- Do not stand on the seat.
- Do not stand on the table.
- Do not let children play with this product.
- Maximum load per seat: 250 lbs.

At the beginning of the season

- Check to ensure that all components and fixings of this product are secure, do not use if you have any doubts about its fitness for purpose.

At the end of the season

- This product should be stored under cover during prolonged spells of adverse weather (wet or cold) and also during the winter (ideally in a garden shed or garage).
- Always clean and dry thoroughly before storage.

Tips for Cushions

In order to compress the package, we put the cushions in the gap of some parts. So there may be crinkle on the fabric. Don't worry. Just flap every corner of the cushion evenly and it will get back into its original shape soon.

1



2

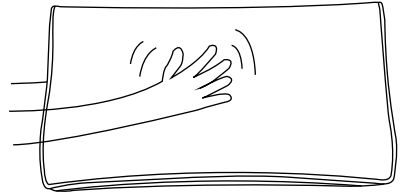



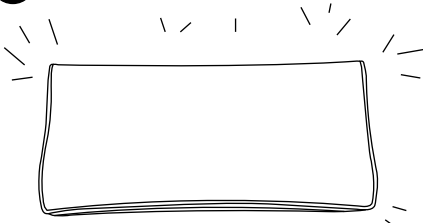

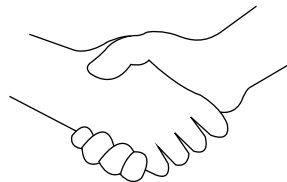

3

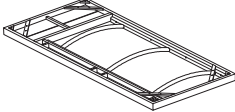
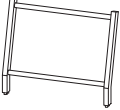

OK

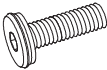
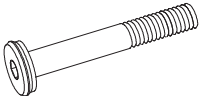

COMPONENT LIST - RIGHT LOVESEAT

Item no.	Reference Image	Description	Qty.
A		Right Seat Panel	1
B		Back Panel	2
C		Leg	4
F		Seat Cushion	1
H		Back Cushion	2
J		Washer	20
K		M6X12 Head Cap Screws	12
L		M6X60 Head Cap Screws	8
M		Allen Key	1

- 1 Attach the Back Panels (B) to the Right Seat Panel (A).

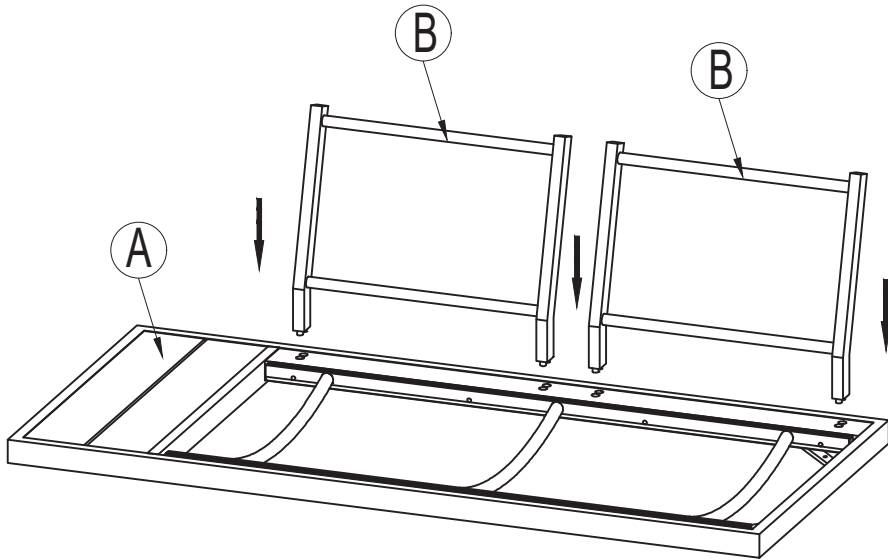

2 Attach the Right Seat Panel (A) to the Back Panels (B) by securing with M6X60 Head Cap Screws (L) and Washers (J). Do this in 4 places.

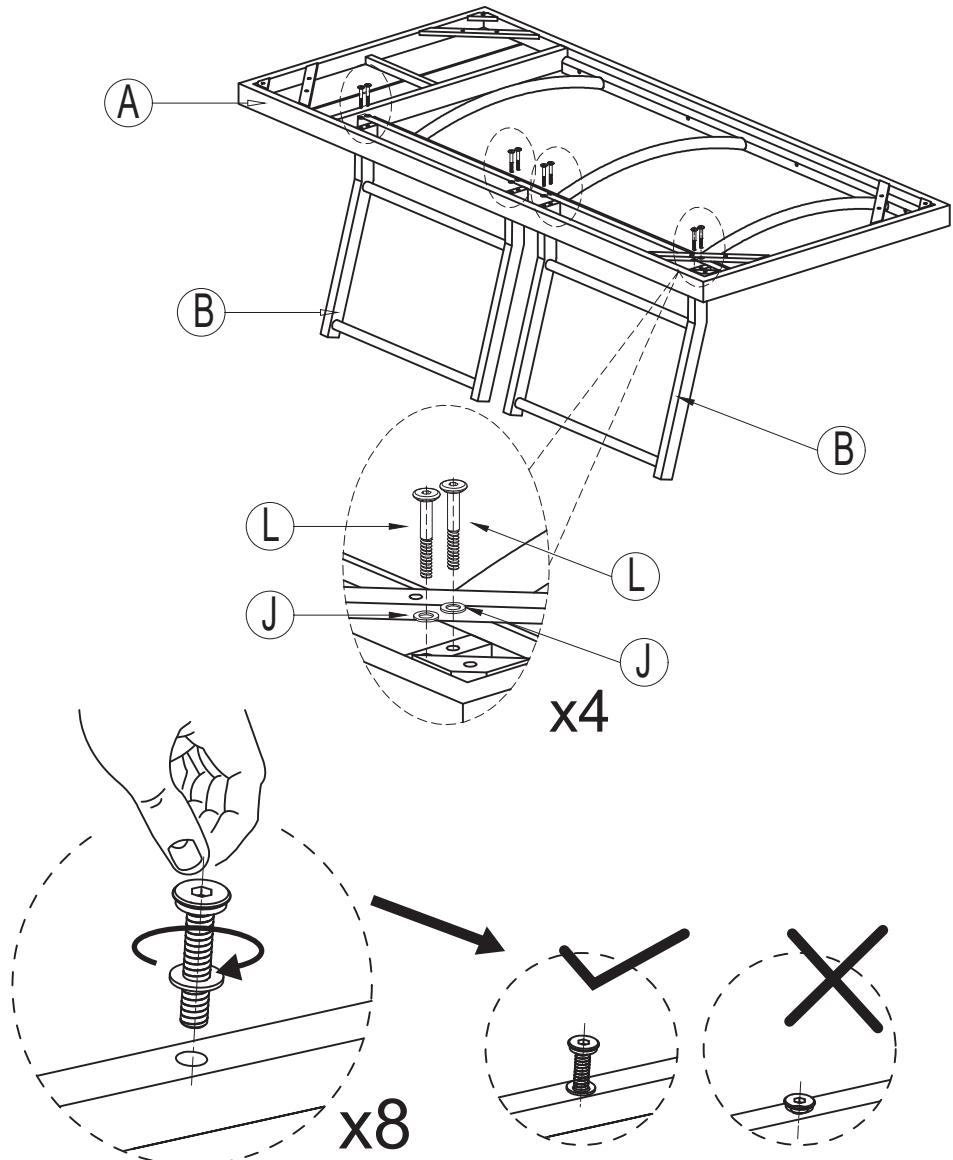

NOTE: DO NOT TIGHTEN THE SCREWS COMPLETELY.

3 Attach the Legs (C) to the Right Seat Panel (A) by securing with M6X12 Head Cap Screws (K) and Washers (J). Do this in 4 places.

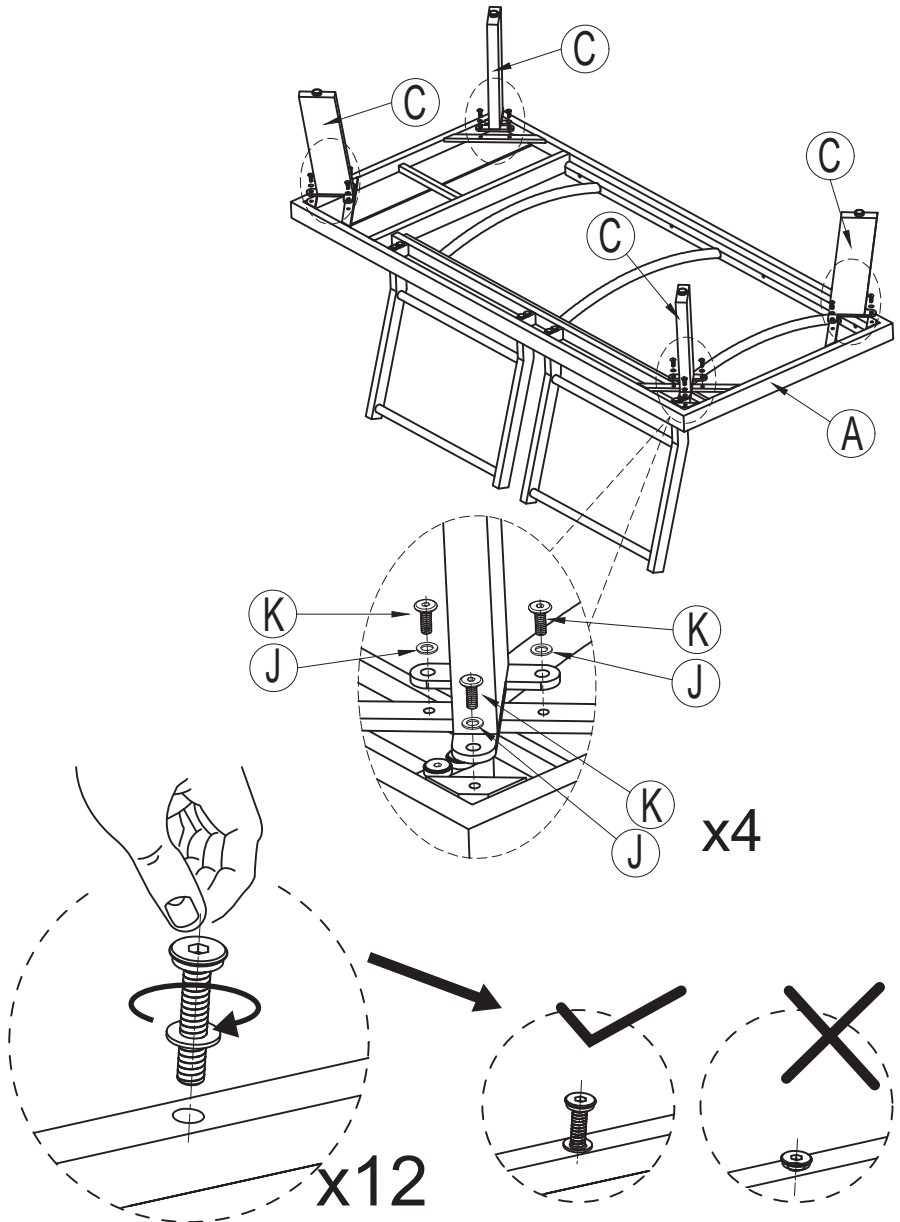

NOTE: DO NOT TIGHTEN THE SCREWS COMPLETELY.

4

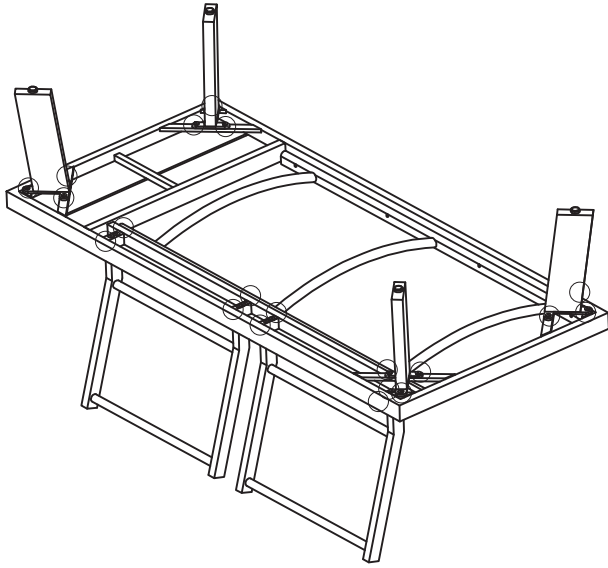

Tighten all 20 Screws into place with Allen Key (M).

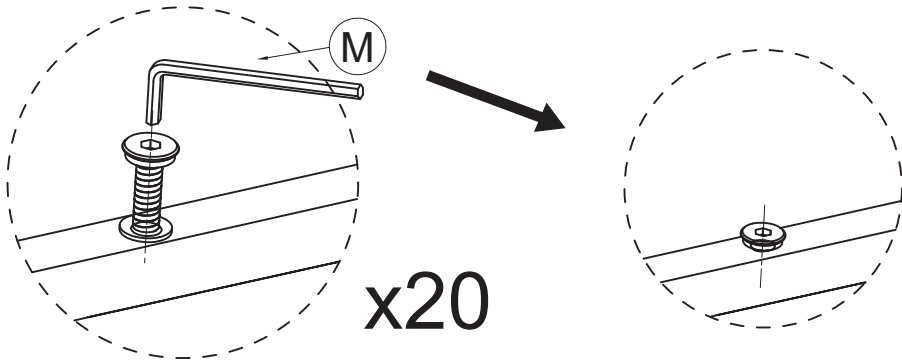

NOTE:IF ANY SCREW HOLES CANNOT BE ALIGNED,
LOOSEN ALL THE SCREWS AND GO BACK STEP
1 AND RESTART ASSEMBLY.

5

Place the Loveseat on a level surface and adjust height for balance.

Place the Seat Cushion (F) and Back cushions (H) on the loveseat. Your Loveseat is ready for use.

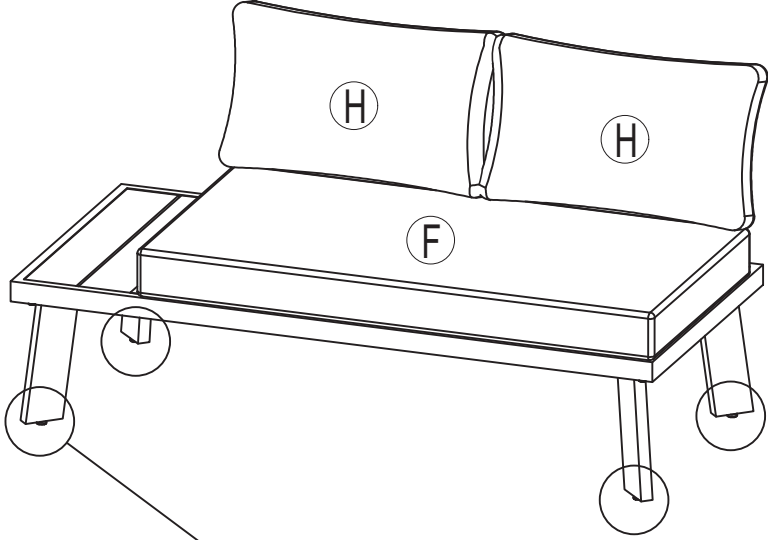

Adjust Pre-installed levellers height for balance

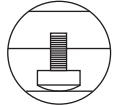



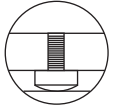



Adjust height for balance

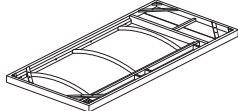
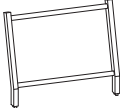

Adjust low for balance

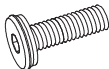
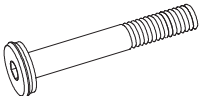
COMPONENT LIST - LEFT LOVESEAT

Item no.	Reference Image	Description	Qty.
N		Left Seat Panel	1
B		Back Panel	2
P		Leg	4
F		Seat Cushion	1
H		Back Cushion	2
J		Washer	20
K		M6X12 Head Cap Screws	12
L		M6X60 Head Cap Screws	8
M		Allen Key	1

- 1 Attach the Back Panels (B) to the Left Seat Panel (N).

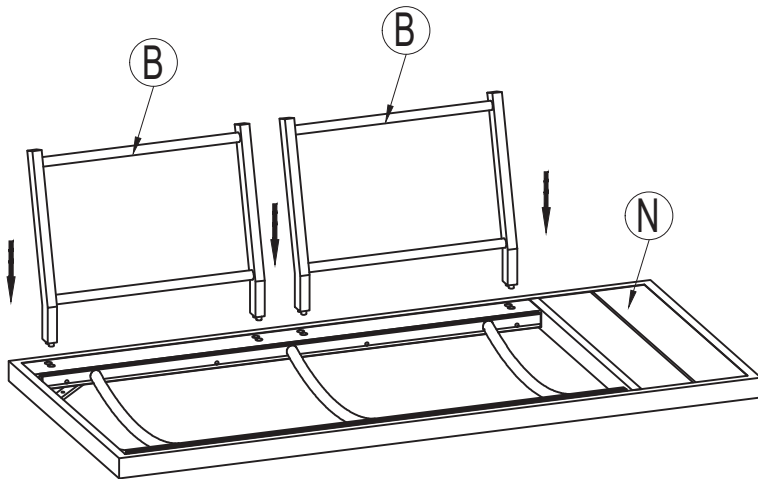

- 2** Attach the Left Seat Panel (N) to the Back Panels (B) by securing with M6X60 Head Cap Screws (L) and Washers (J). Do this in 4 places.

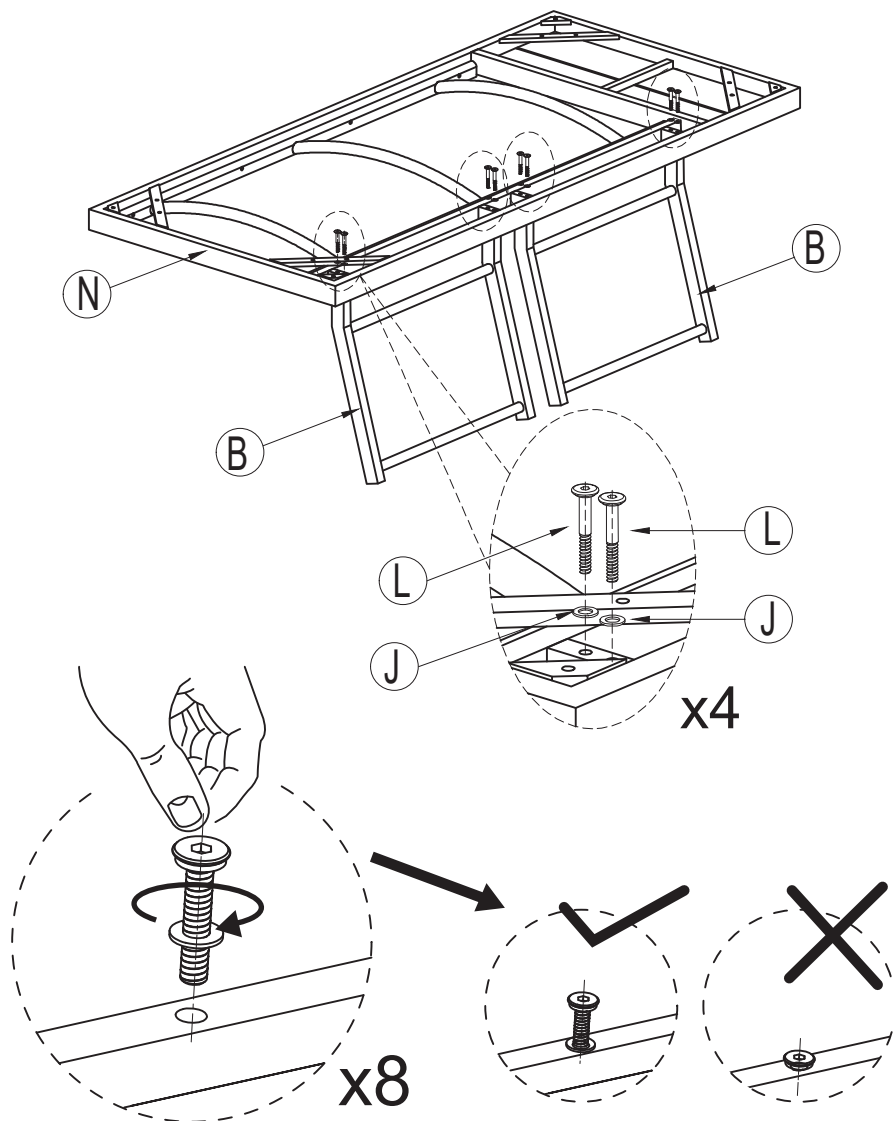

NOTE: DO NOT TIGHTEN THE SCREWS COMPLETELY.

- 3** Attach the Legs (P) to the Left Seat Panel (N) by securing with M6X12 Head Cap Screws (K) and Washers (J). Do this in 4 places.

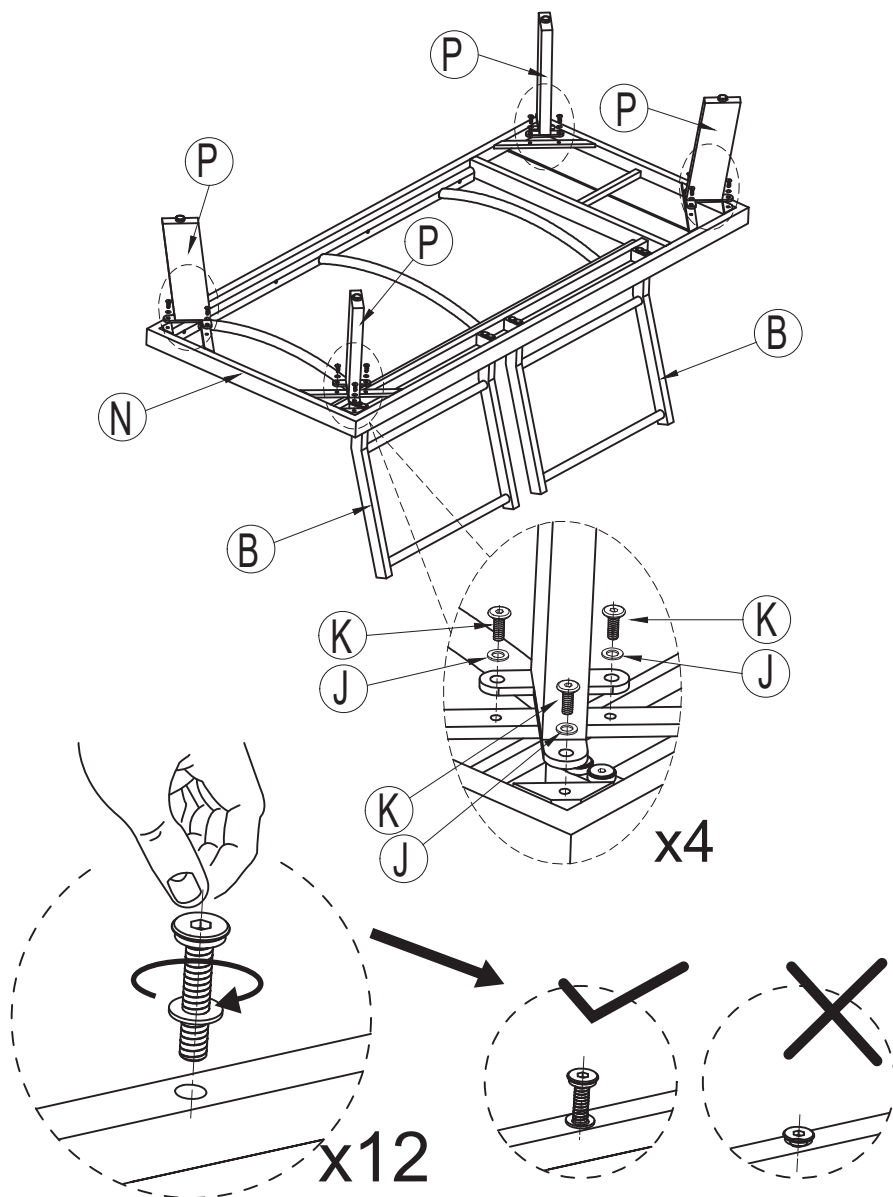

NOTE: DO NOT TIGHTEN THE SCREWS COMPLETELY.

4

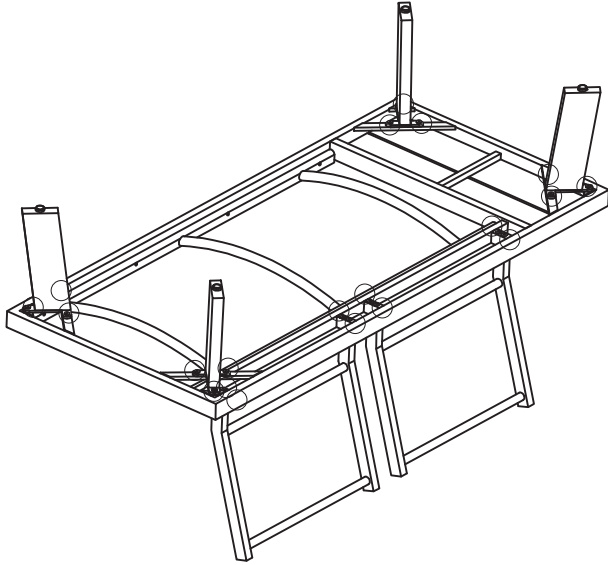

Tighten all 20 Screws into place with Allen Key (M).

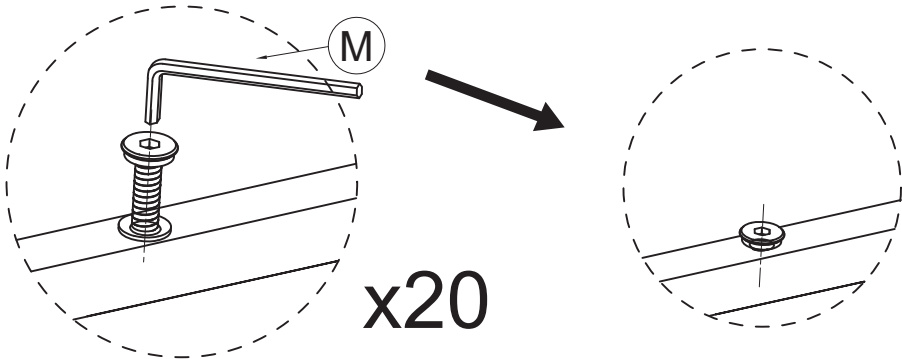

NOTE:IF ANY SCREW HOLES CANNOT BE ALIGNED,
LOOSEN ALL THE SCREWS AND GO BACK STEP
1 AND RESTART ASSEMBLY.

5

Place the Loveseat on a level surface and adjust height for balance.

Place the Seat Cushion (F) and Back cushion (H) on the loveseat. Your Loveseat is ready for use.

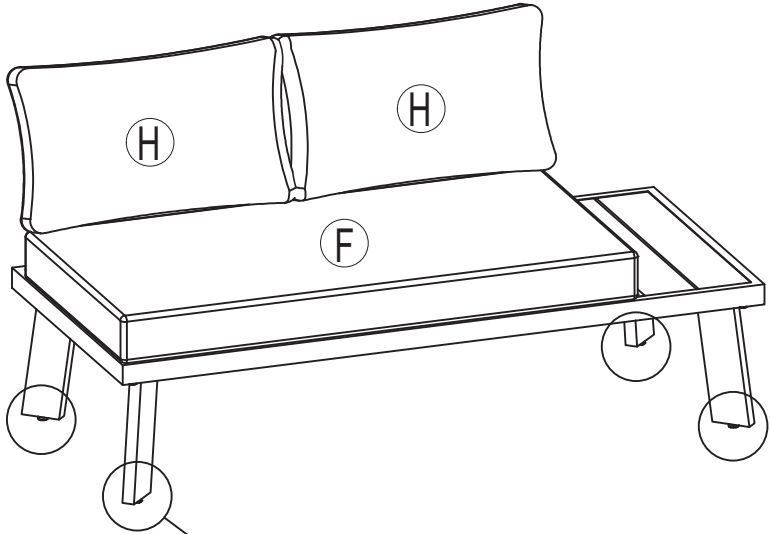

Adjust Pre-installed levellers height for balance

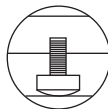



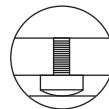



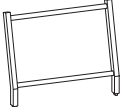

Adjust height for balance

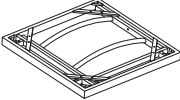
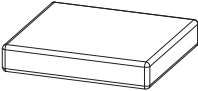

Adjust low for balance

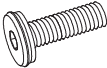
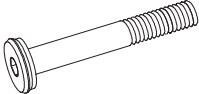
COMPONENT LIST - CORNER SOFA

Item no.	Reference Image	Description	Qty.
B		Back Panel	2
C		Leg	4
D		Seat Base	1
G		Seat Cushion	1
H		Back Cushion	1
I		Short Cushion	1
J		Washer	20
K		M6X12 Head Cap Screws	12
L		M6X60 Head Cap Screws	8
M		Allen Key	1

1 Attach the Back Panels (B) to the Seat Base (D).

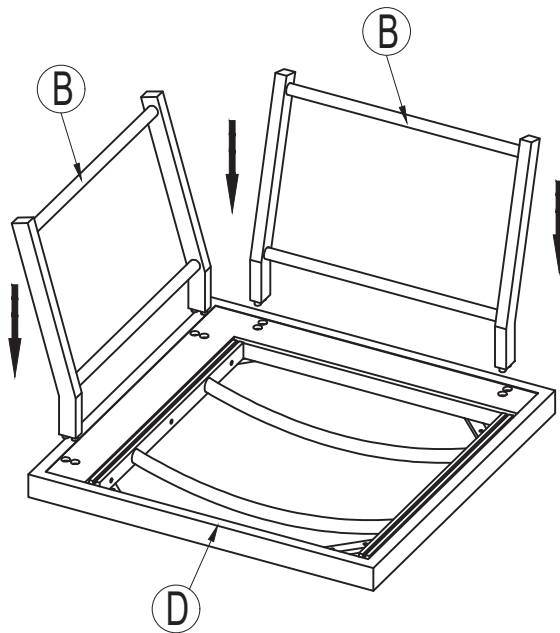

2 Attach the Seat Base (D) to the Back Panels (B) by securing with M6X60 Head Cap Screws (L) and Washers (J). Do this in 4 places.

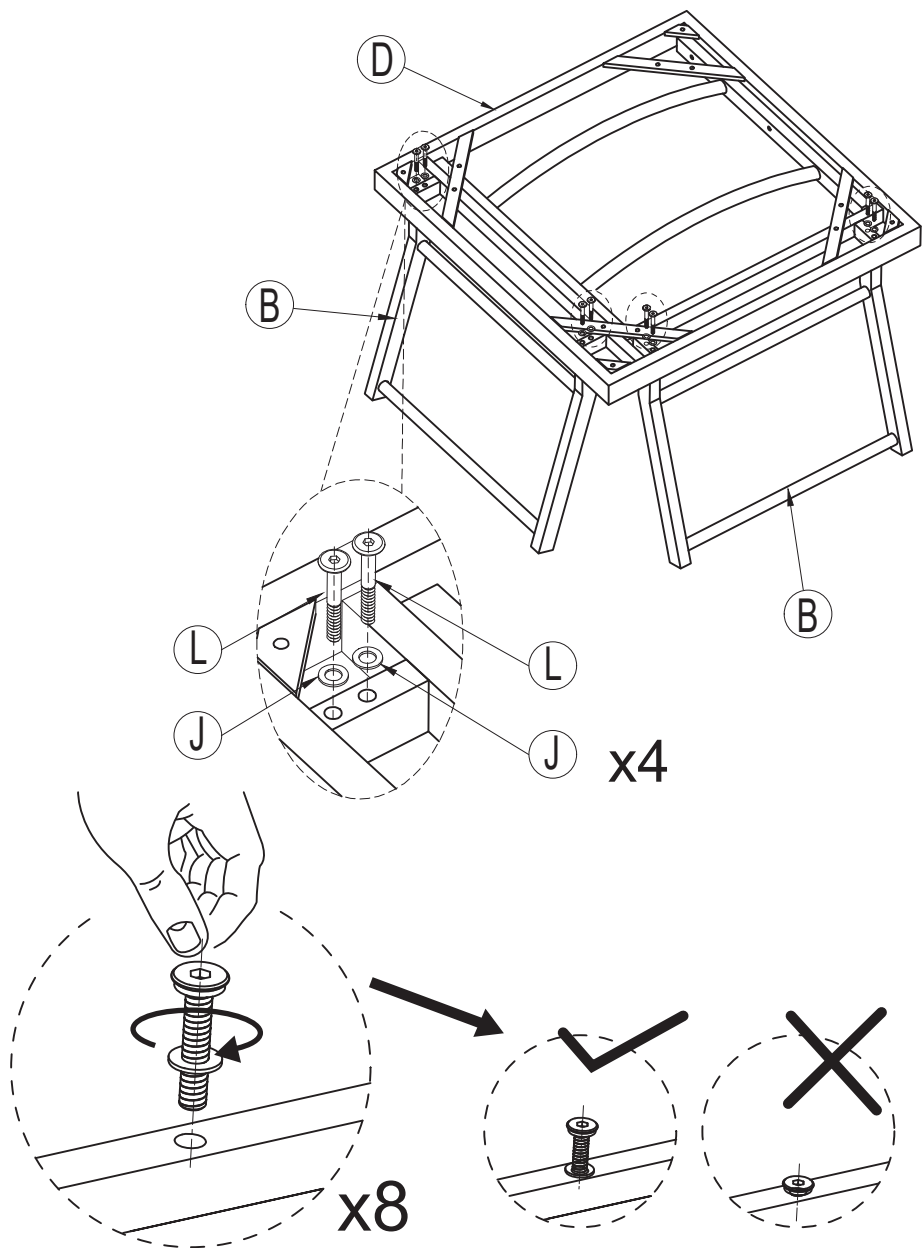

NOTE: DO NOT TIGHTEN THE SCREWS COMPLETELY.

- 3** Attach the Legs (C) to the Seat Base(D) by securing with M6X12 Head Cap Screws (K) and Washers (J). Do this in 4 places.

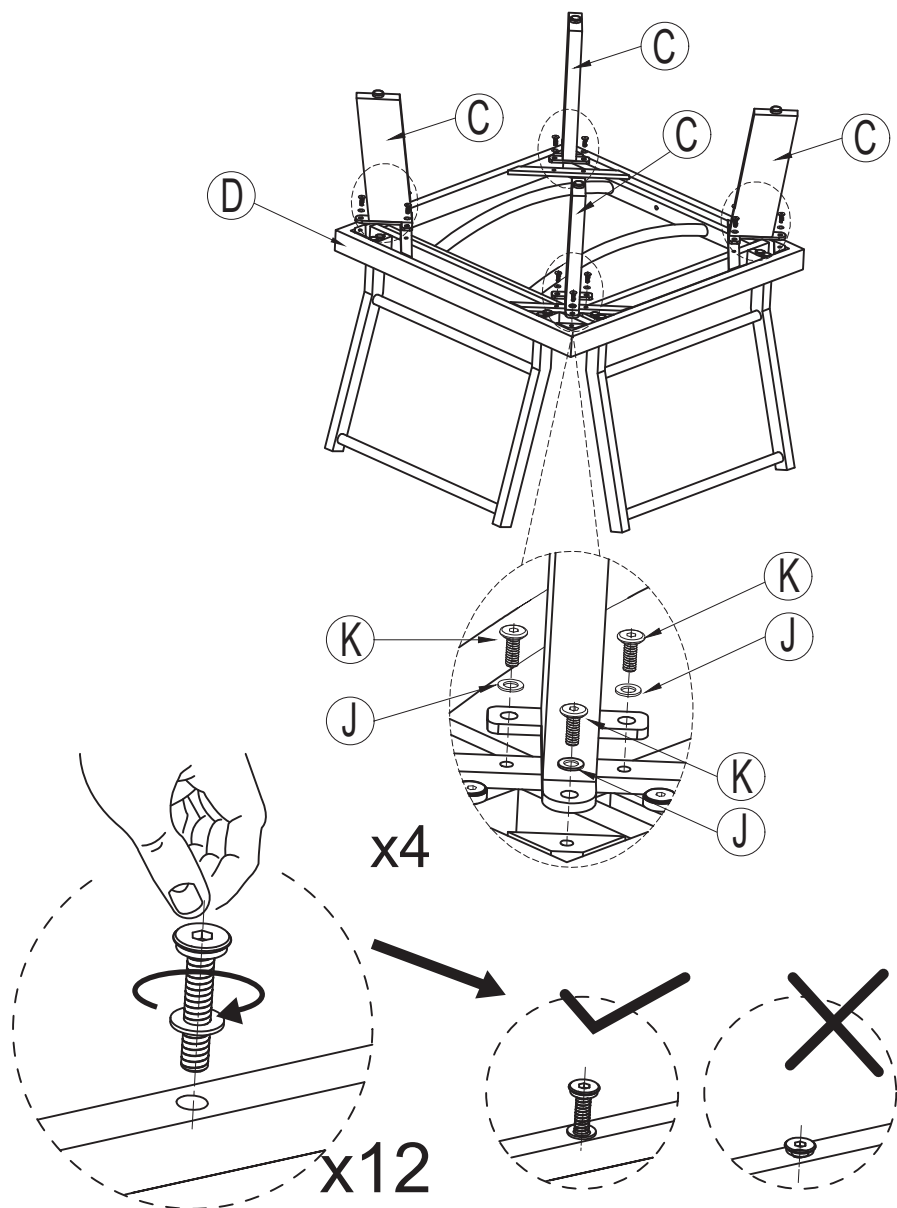

NOTE: DO NOT TIGHTEN THE SCREWS COMPLETELY.

4

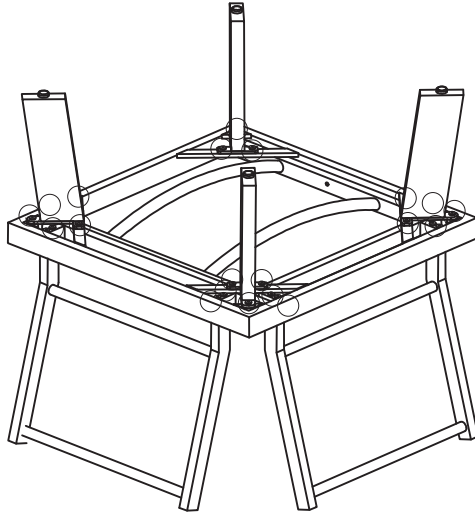

Tighten all 20 Screws into place with Allen Key (M).

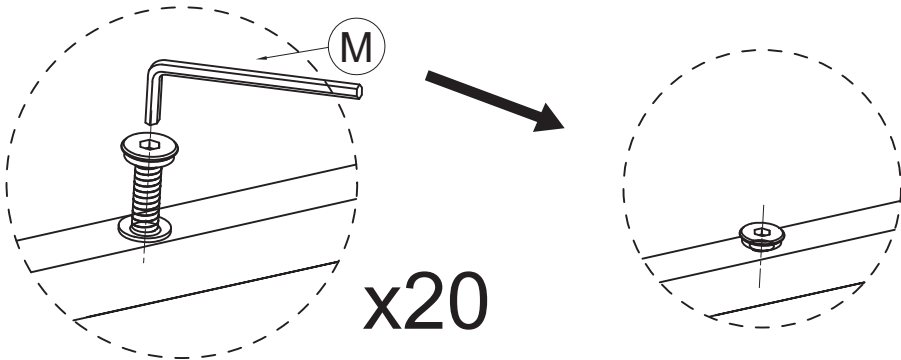

NOTE:IF ANY SCREW HOLES CANNOT BE ALIGNED,
LOOSEN ALL THE SCREWS AND GO BACK STEP
1 AND RESTART ASSEMBLY.

5

Place the sofa on a level surface and adjust height for balance. Place the Seat Cushion (G) and Back cushions (H) & (I) on the sofa.

Your sofa is ready for use.

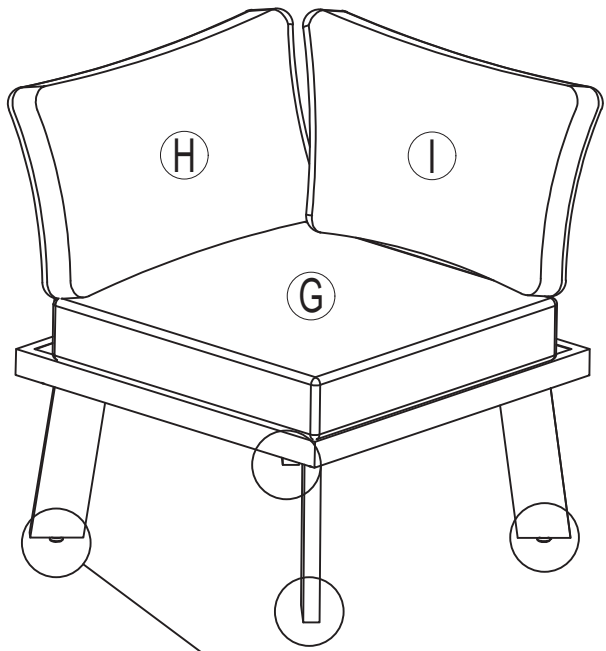

Adjust Pre-installed levellers height for balance

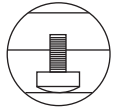

Adjust height for balance

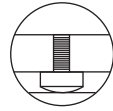

Adjust low for balance

COMPONENT LIST - TABLE

Item no.	Reference Image	Description	Qty.
C		Table Leg	4
E		Table Top	1
J		Washer	12
K		M6X12 Head Cap Screws	12
M		Allen Key	1

1 Attach the Table Legs (C) to the Table Top (E) by securing with M6X12 Head Cap Screws (K) and Washers (J). Do this in 4 places.

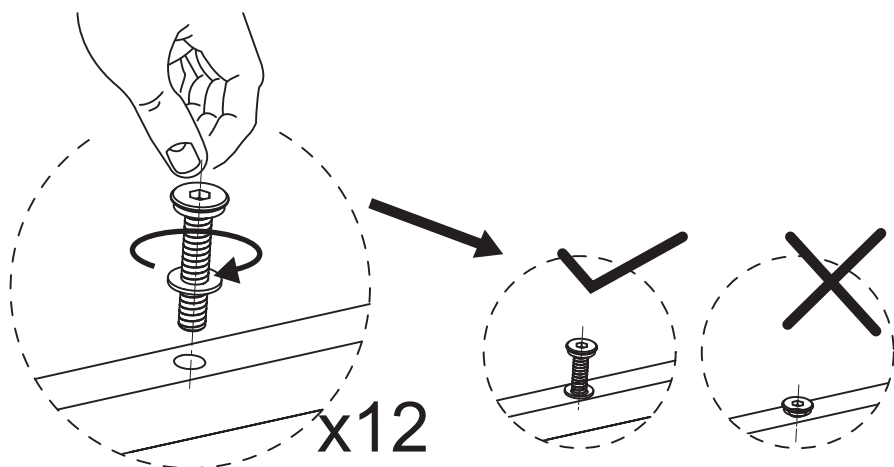
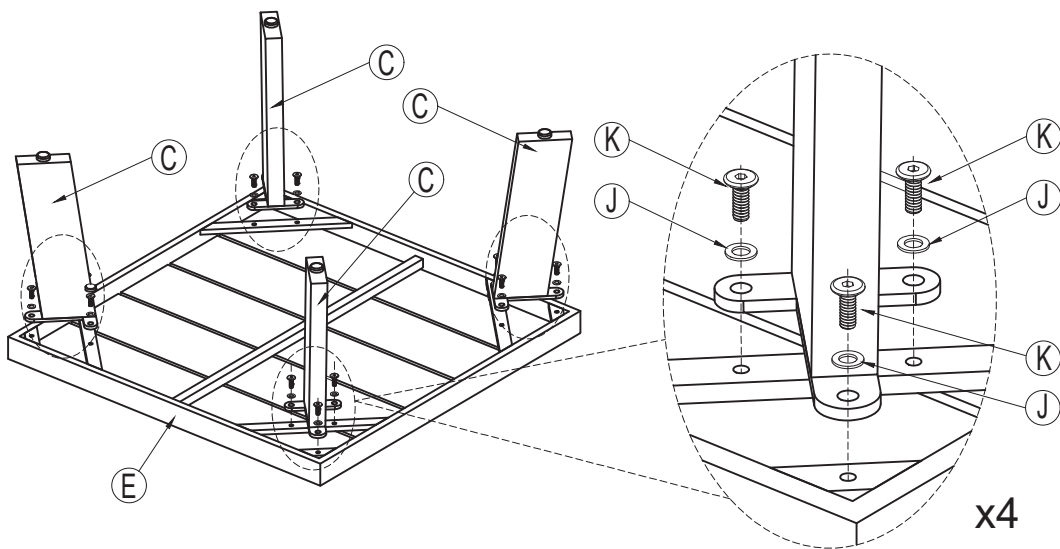

NOTE: DO NOT TIGHTEN THE SCREWS COMPLETELY.

2

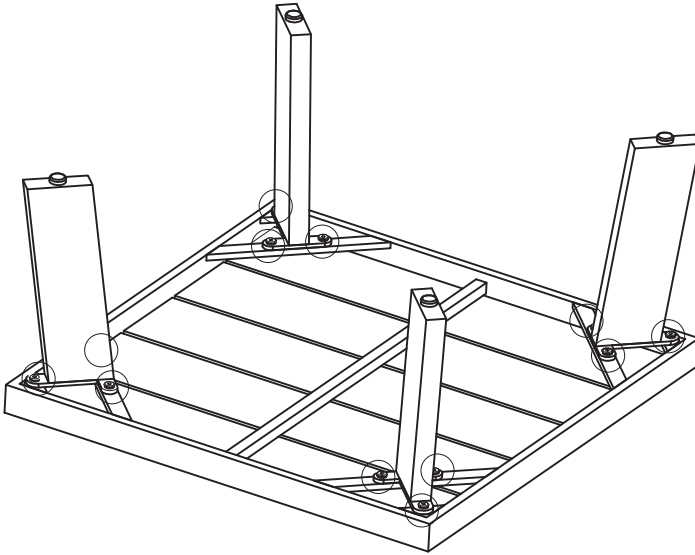

Tighten all 12 Screws into place with Allen Key (M).

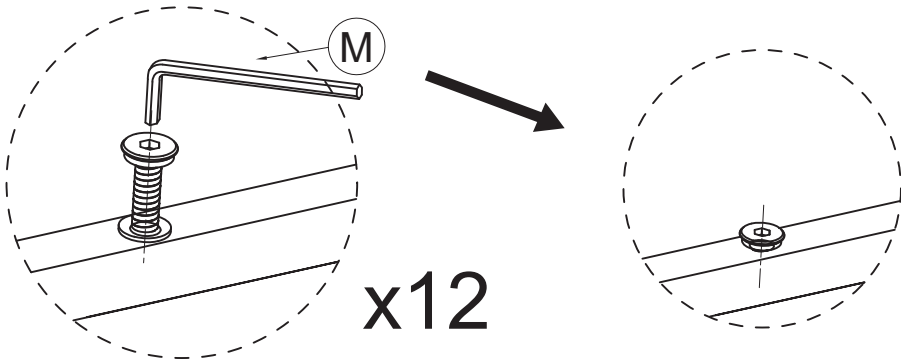

NOTE:IF ANY SCREW HOLES CANNOT BE ALIGNED,
LOOSEN ALL THE SCREWS AND GO BACK STEP
1 AND RESTART ASSEMBLY.

3

Place the Table on a level surface and adjust height for balance. Your Table is ready for use.

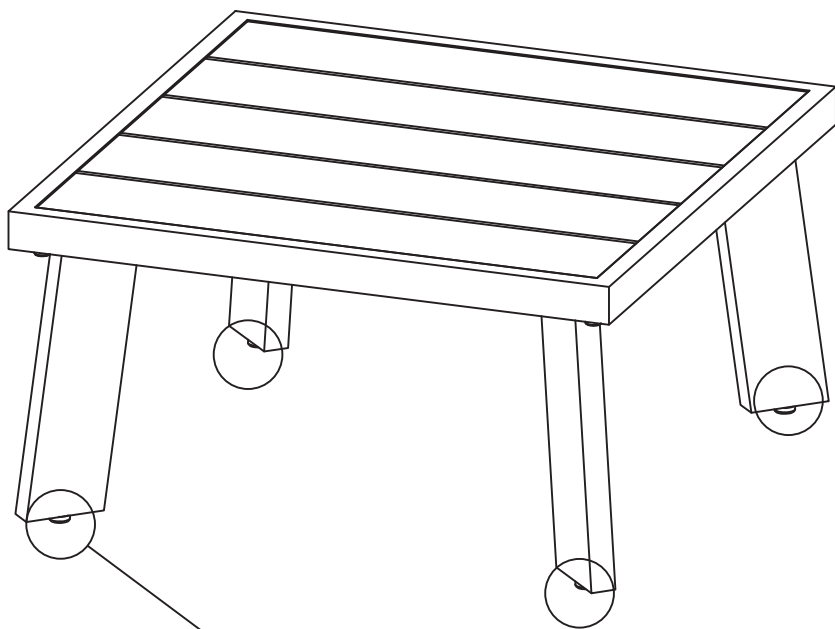

Adjust Pre-installed levellers height for balance

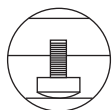

Adjust height for balance

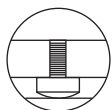

Adjust low for balance