

Assembling Instruction

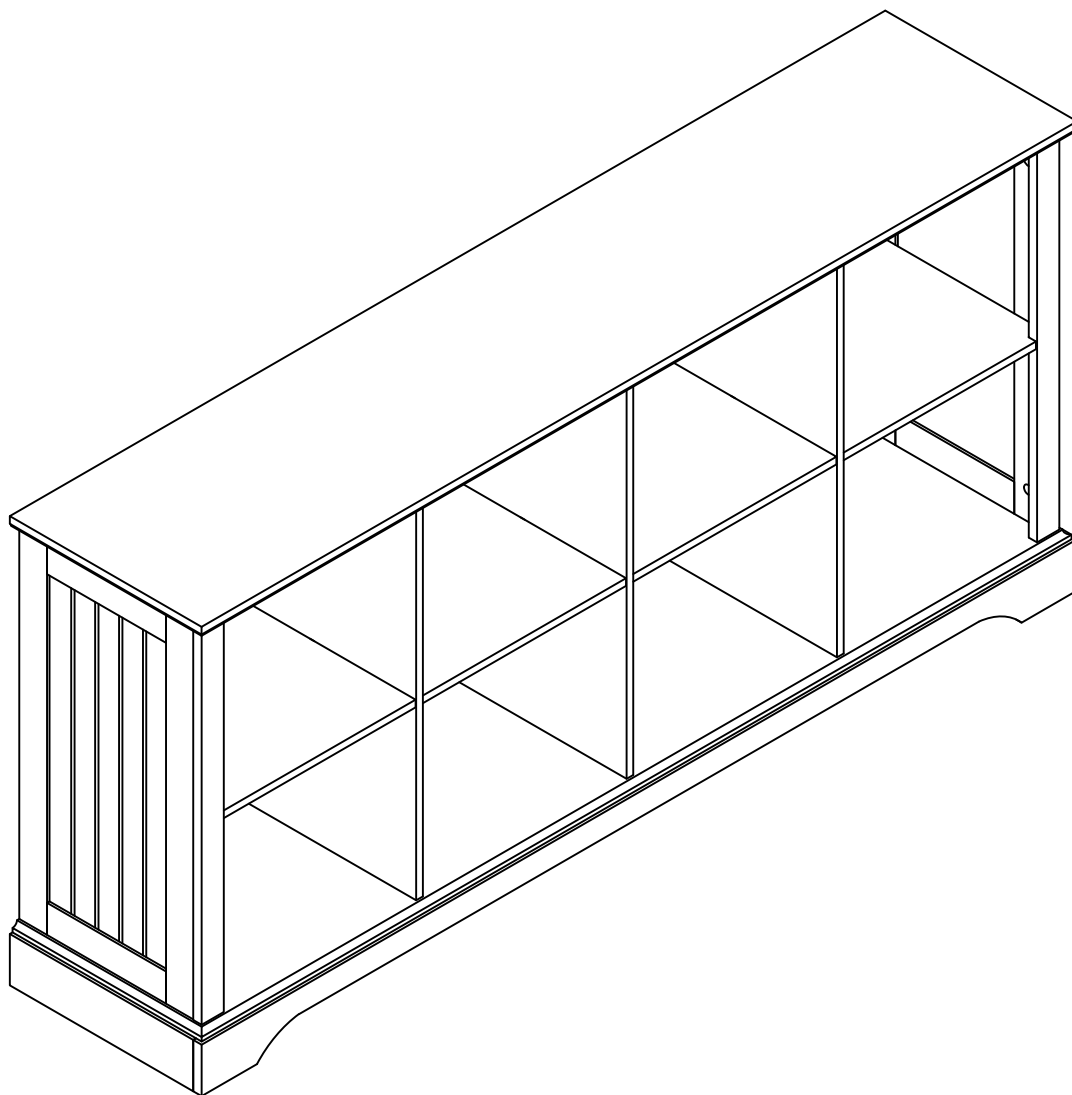

ATTENTION

If there is any missing, please kindly send us messages to let us know the name of missing part regarding to the first page of instructions.

We will send replacement to you asap. We are concerned about each customer's experience, if there is any loss or damage, please contact us at any time, we will provide effective solutions.



General Assembly Guidelines

- I. Ensure that all parts and hardware are available before beginning assembly.
- II. Follow each step carefully to ensure the proper assembly of this product.
- III. Two people are recommended for ease in the assembly of this product.
- IV. The three main types of hardware used to assemble this product are : wood dowels , screws and bolts.
- V. The provided glue is to secure wood dowels in place . When first inserting dowels , locate the appropriate hole for the dowel , place a small amount of glue in the hole and insert the dowel . Wipe away excess glue immediately.

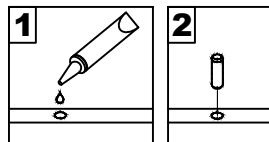

In future assembly steps when dowels are necessary to attach assembly parts together , place a small amount of glue on the end of the dowel before attaching parts together . Wipe away excess glue immediately.

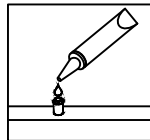

- VI. A Phillips head screwdriver is required for the assembly of this product .

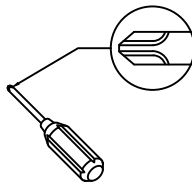



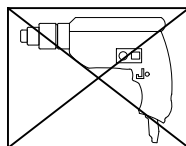



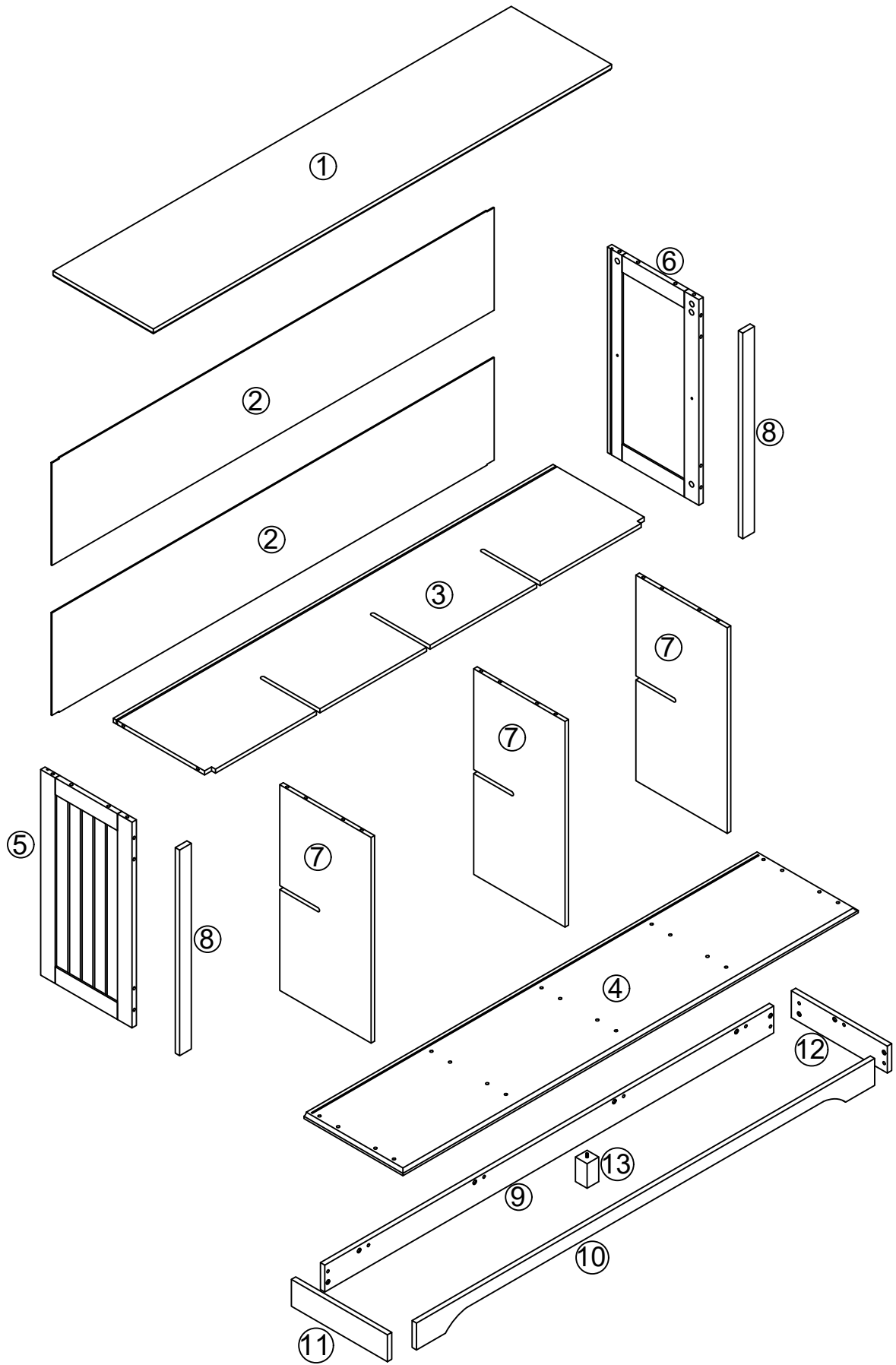







- VI. Power tools should not be used to assemble this product .

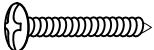

Parts List



Hardware List

A		Ø6x32mm	Cam bolt	18	pcs
B		Ø15x9mm	Cam lock	18	pcs
C		Ø6x50mm	Bolt	10	pcs
D			Hex Key	1	pc
E			Plastic wedge	20	pcs
F		Ø3x17mm	Screw	20	pcs
G		M6x12mm	Bolt	28	pcs
H			Plastic wedge	14	pcs
I		Ø4x40mm	Screw	2	pcs
J		Ø4x14mm	Strip	2	pcs
K			Anti-inversion piece	2	pcs
L		Ø6x40mm	House lizard	2	pcs
M			Glue tube	1	pcs
N		Ø8x30mm	Wooden dowel	24	pcs
O		Ø30mm	Sticker	18	pcs

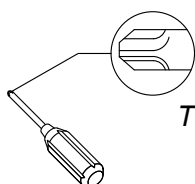

Philips head screwdriver required for assembly
(not included)

*The hardware quantities listed above are required for proper assembly.
Some extra hardware may also have been included.*

Step 1

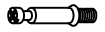

A

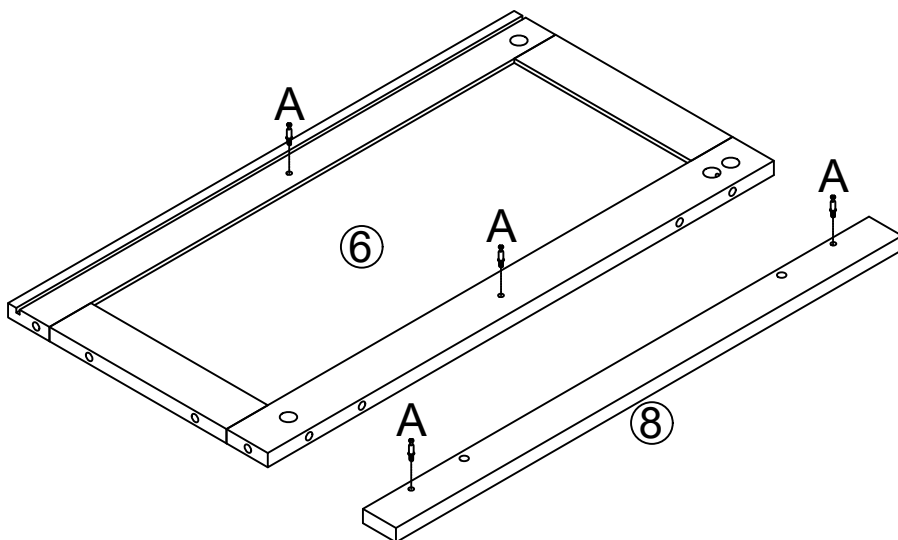
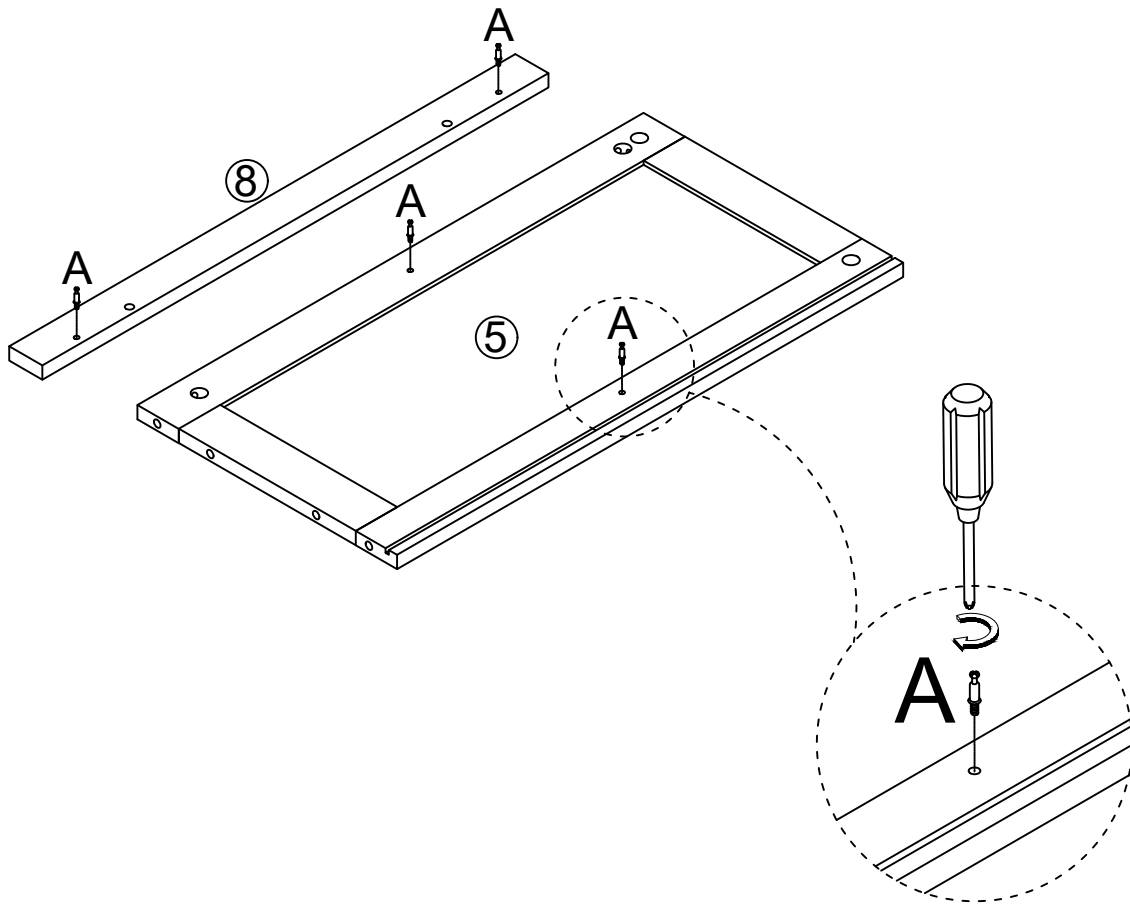

X8



Step 2

N	B
	
X4	X4

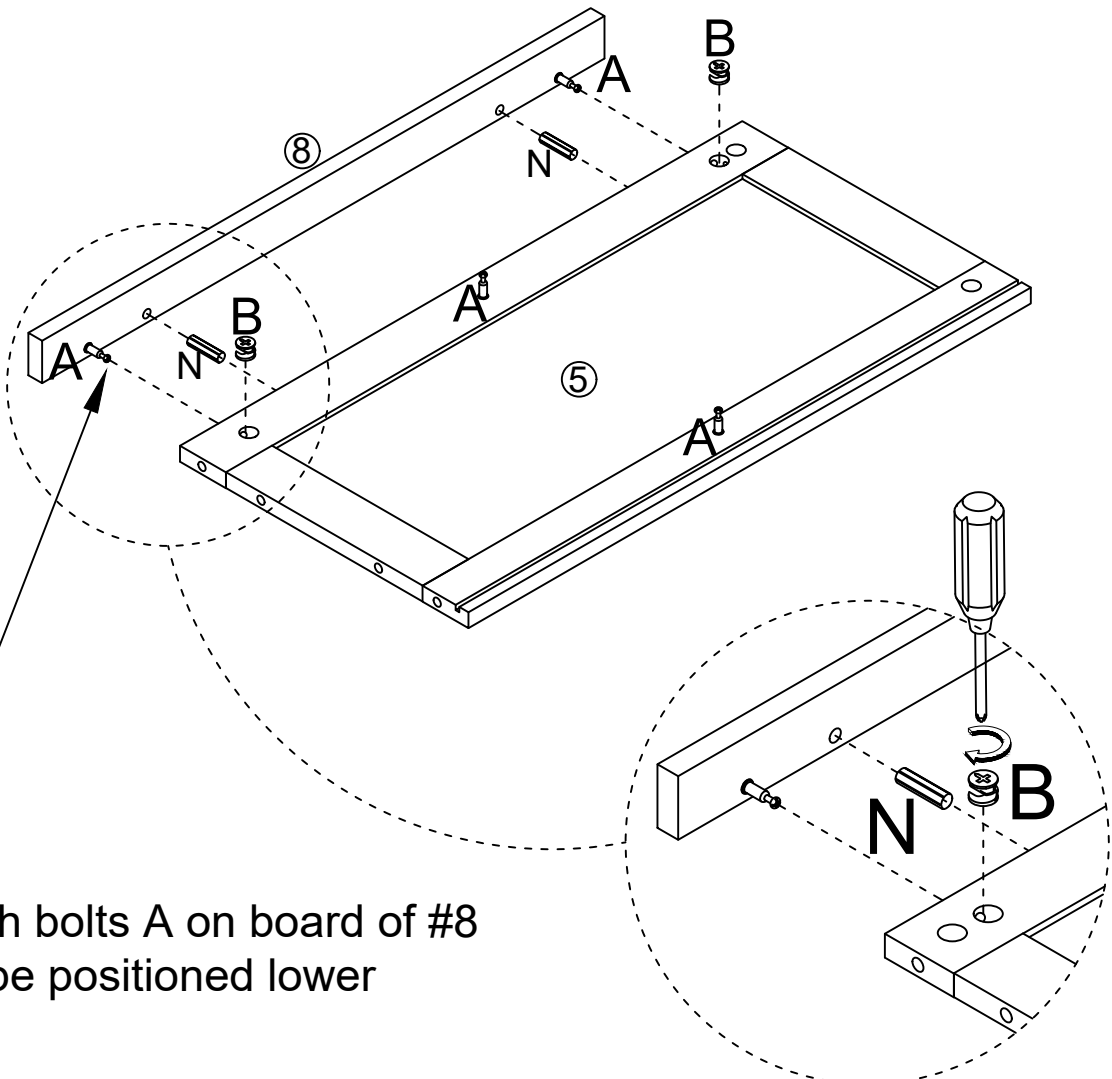

Note:
Side with bolts A on board of #8
should be positioned lower

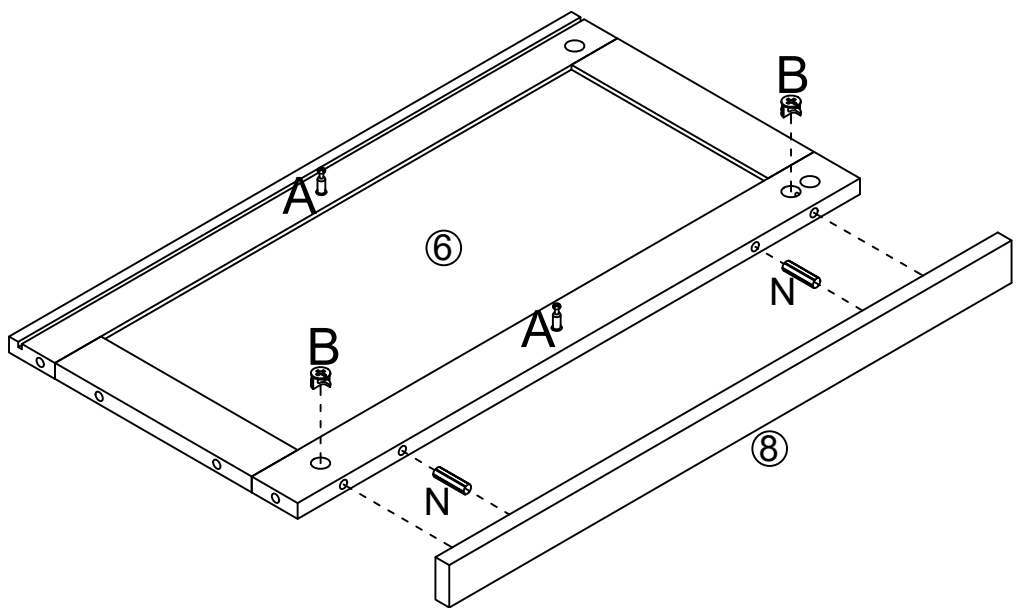

Step 3

B



X2

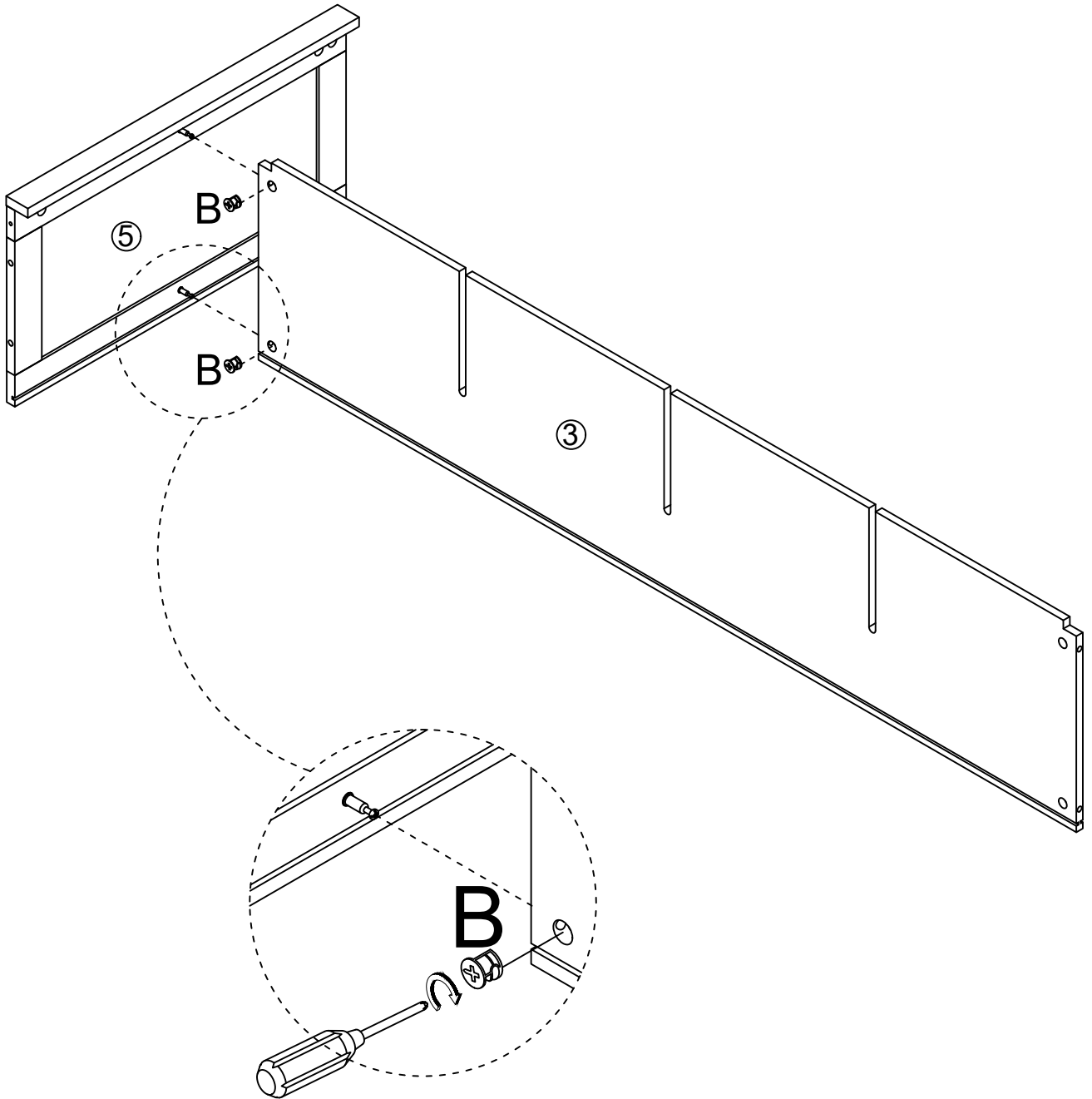

Step 4

B

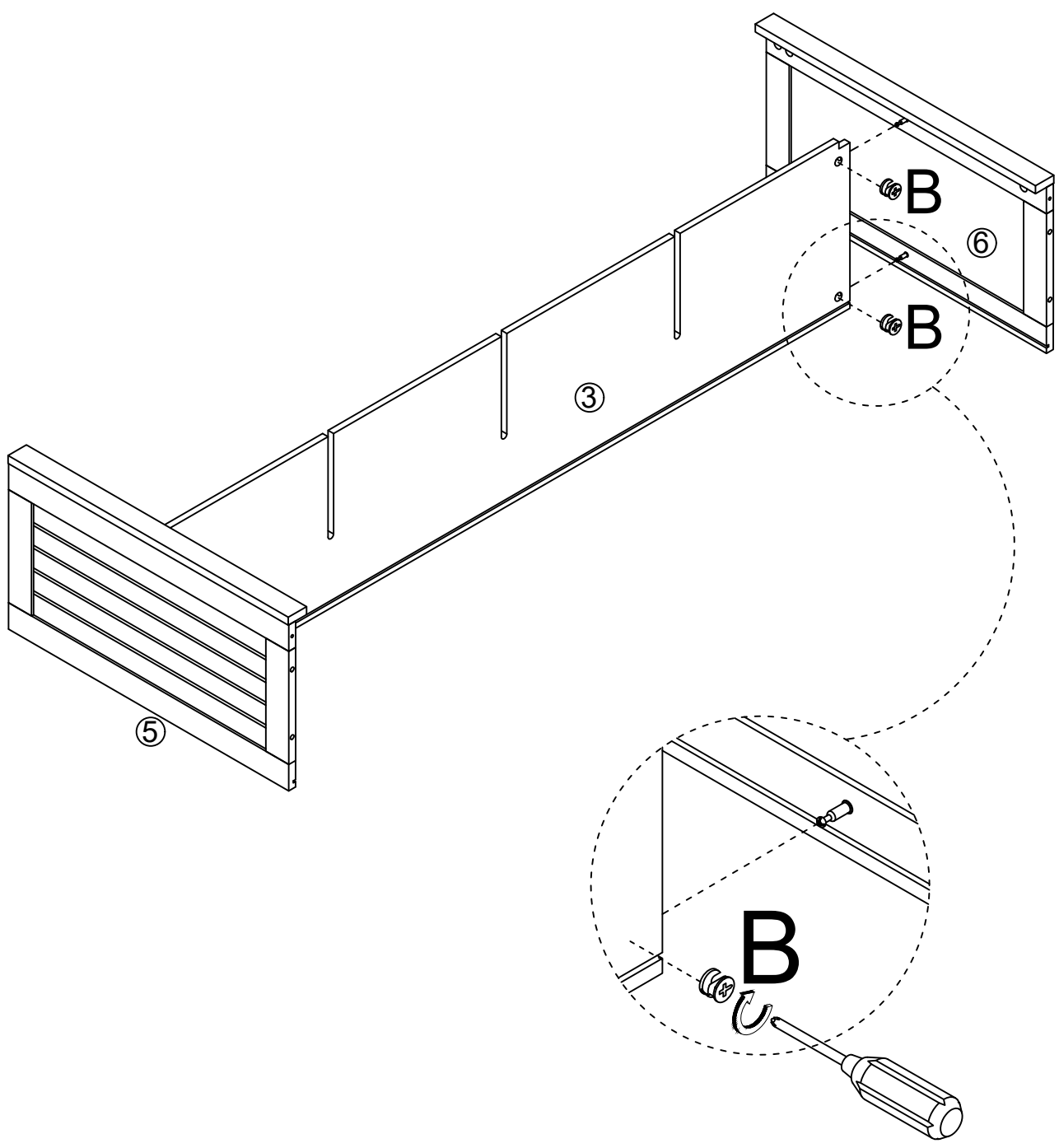
X2



Step 5

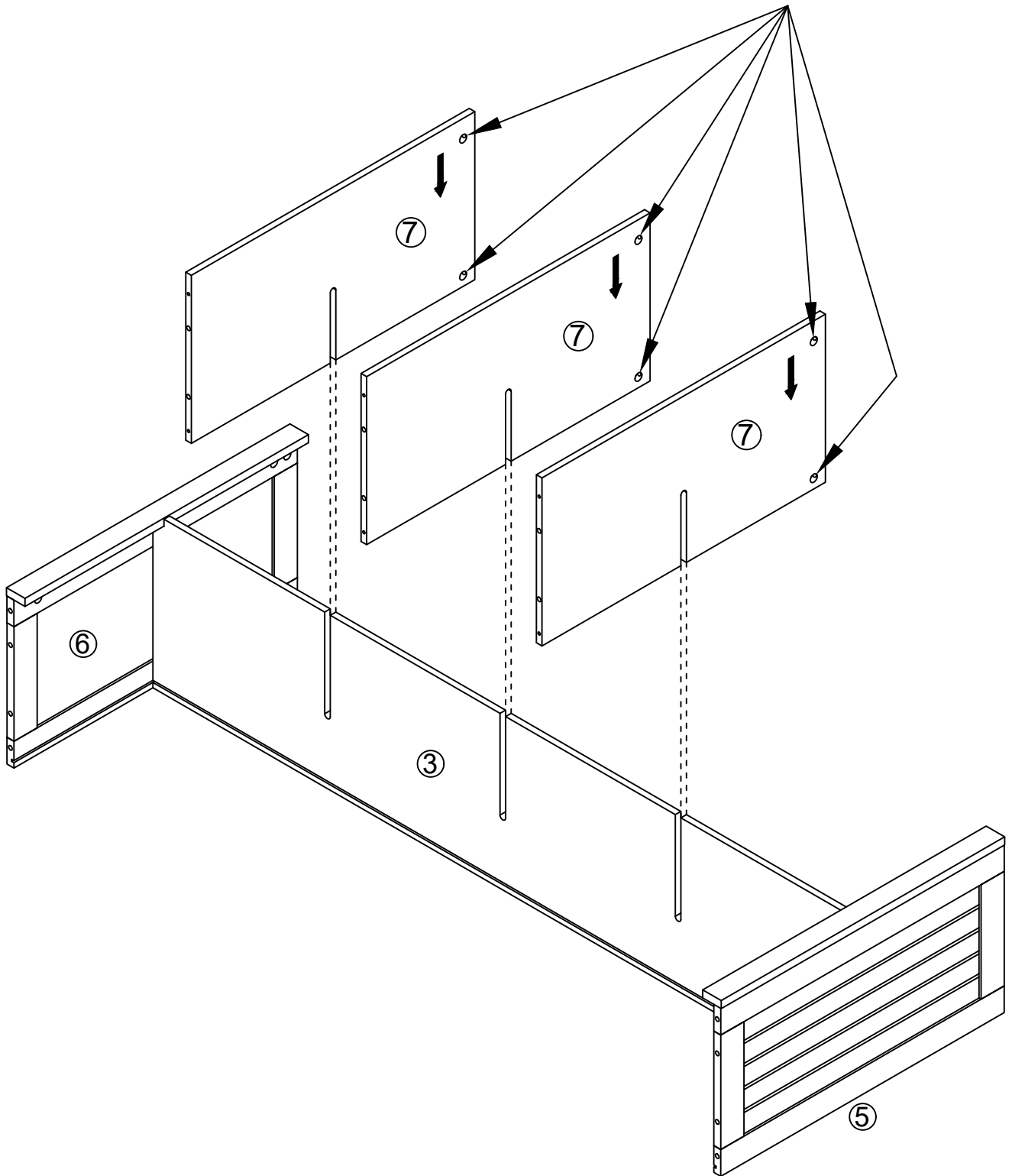

Note: Cam lock hole should be upwards

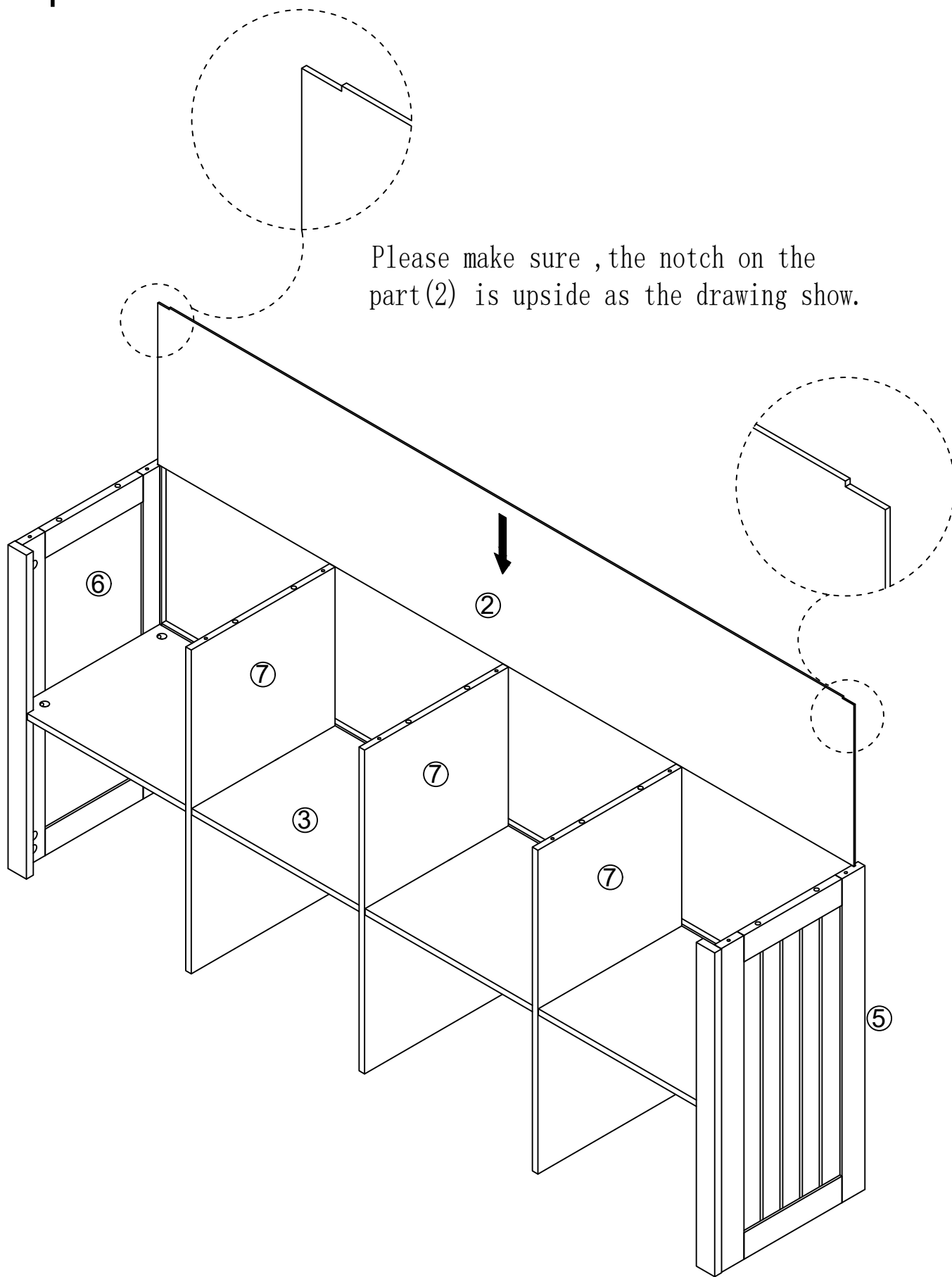

Step 6



Step 7

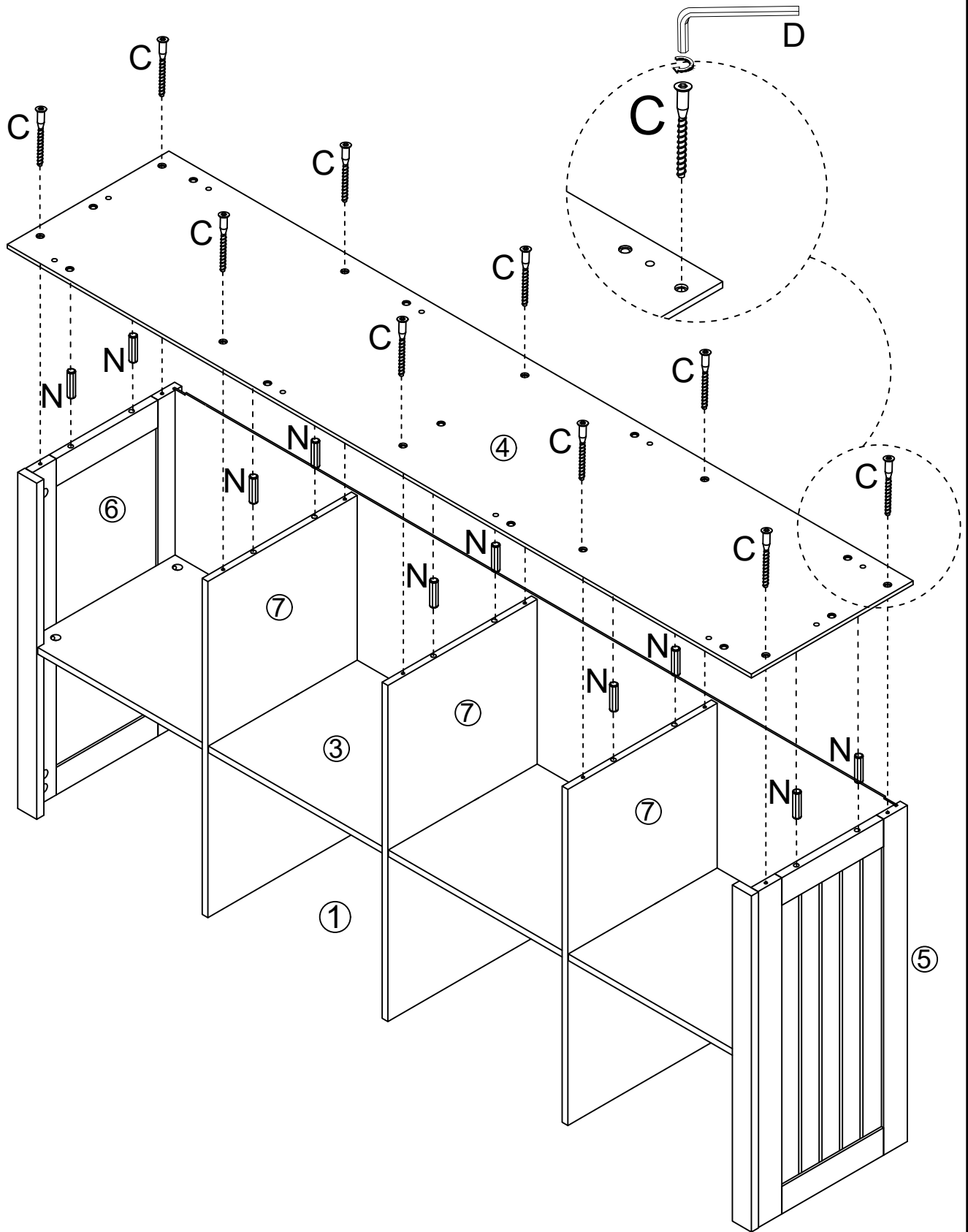

N	C	D
		
X10	X10	X1

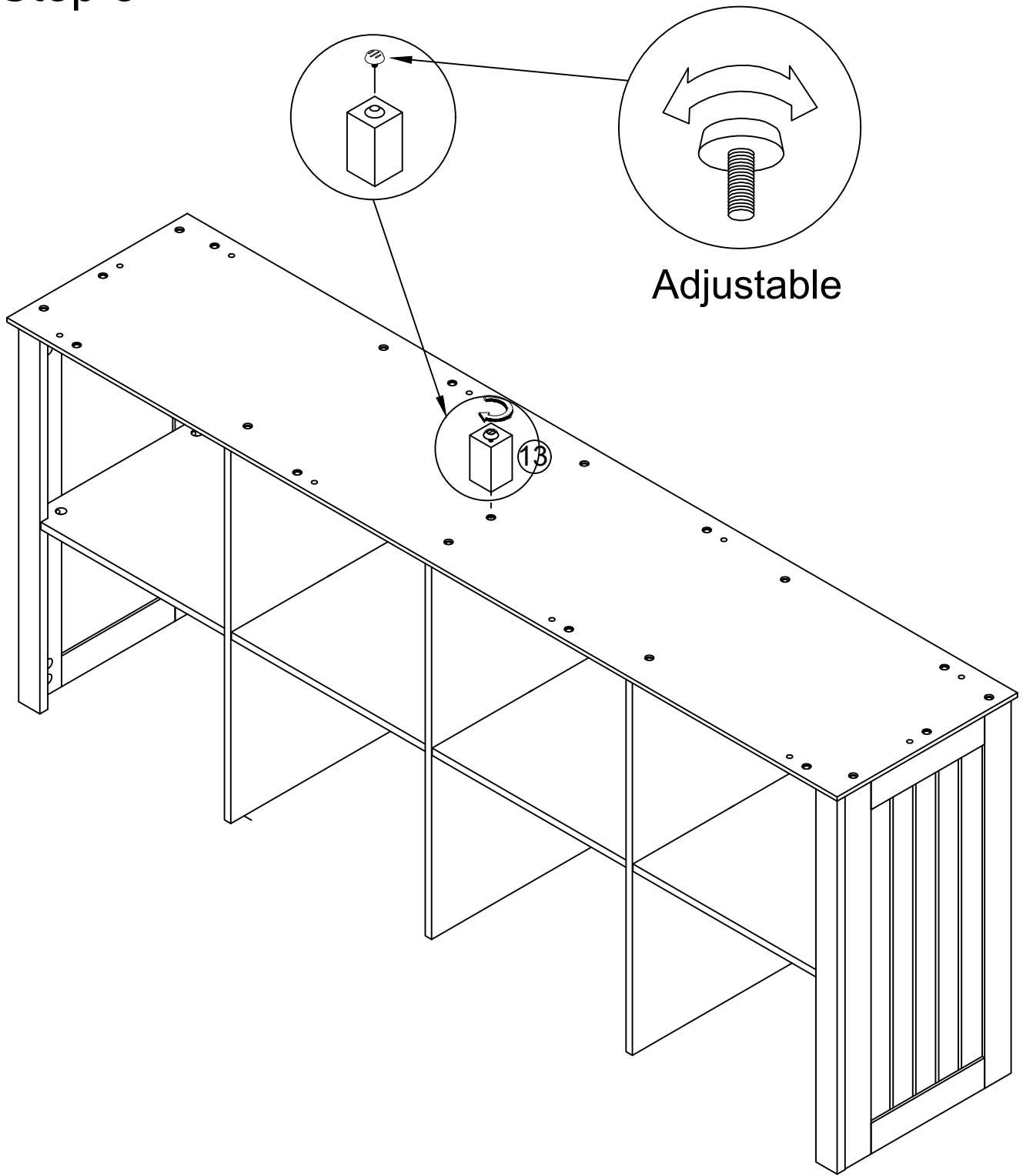

Step 8



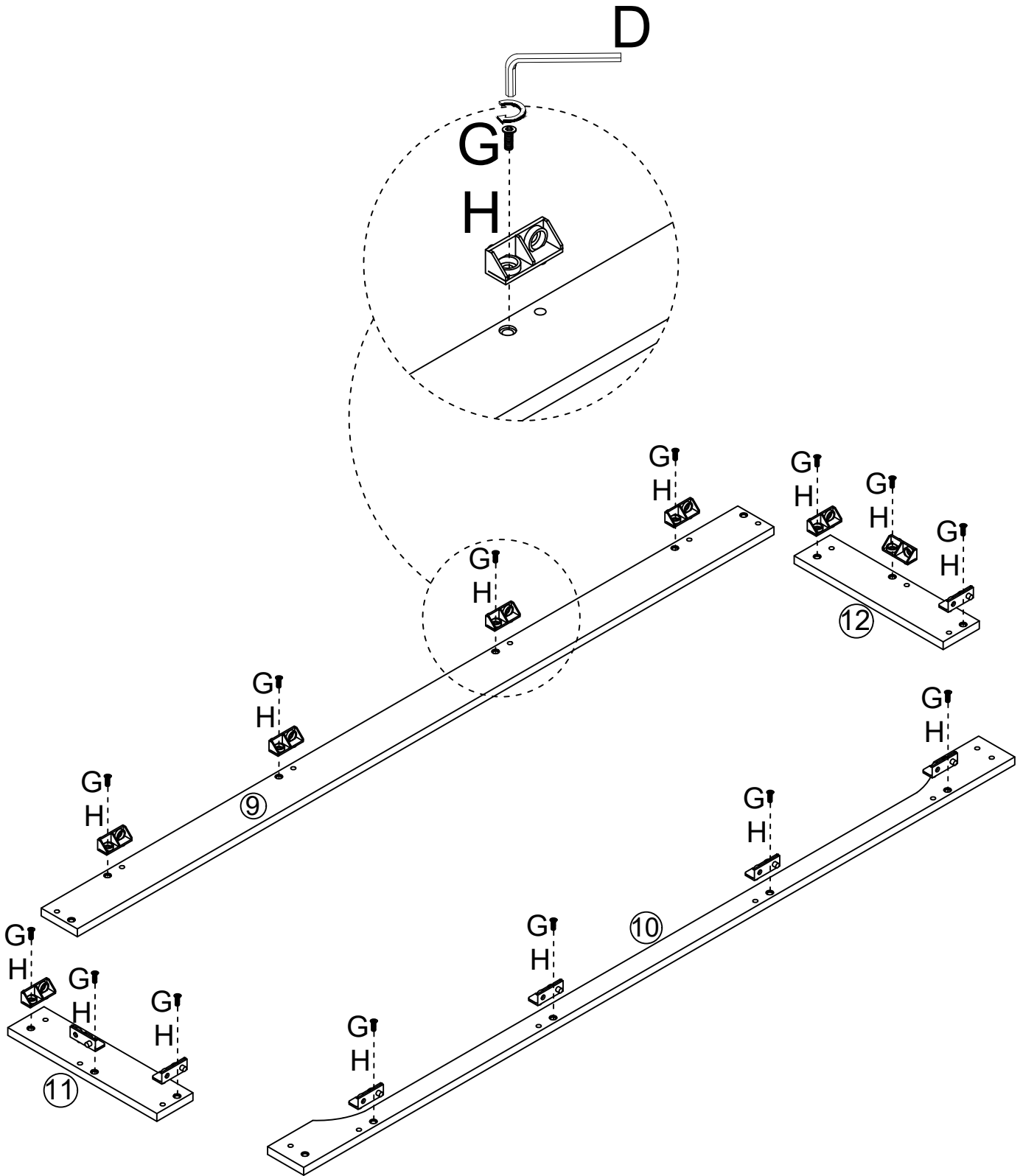

Step 9

H	G	D
		
X14	X14	X1



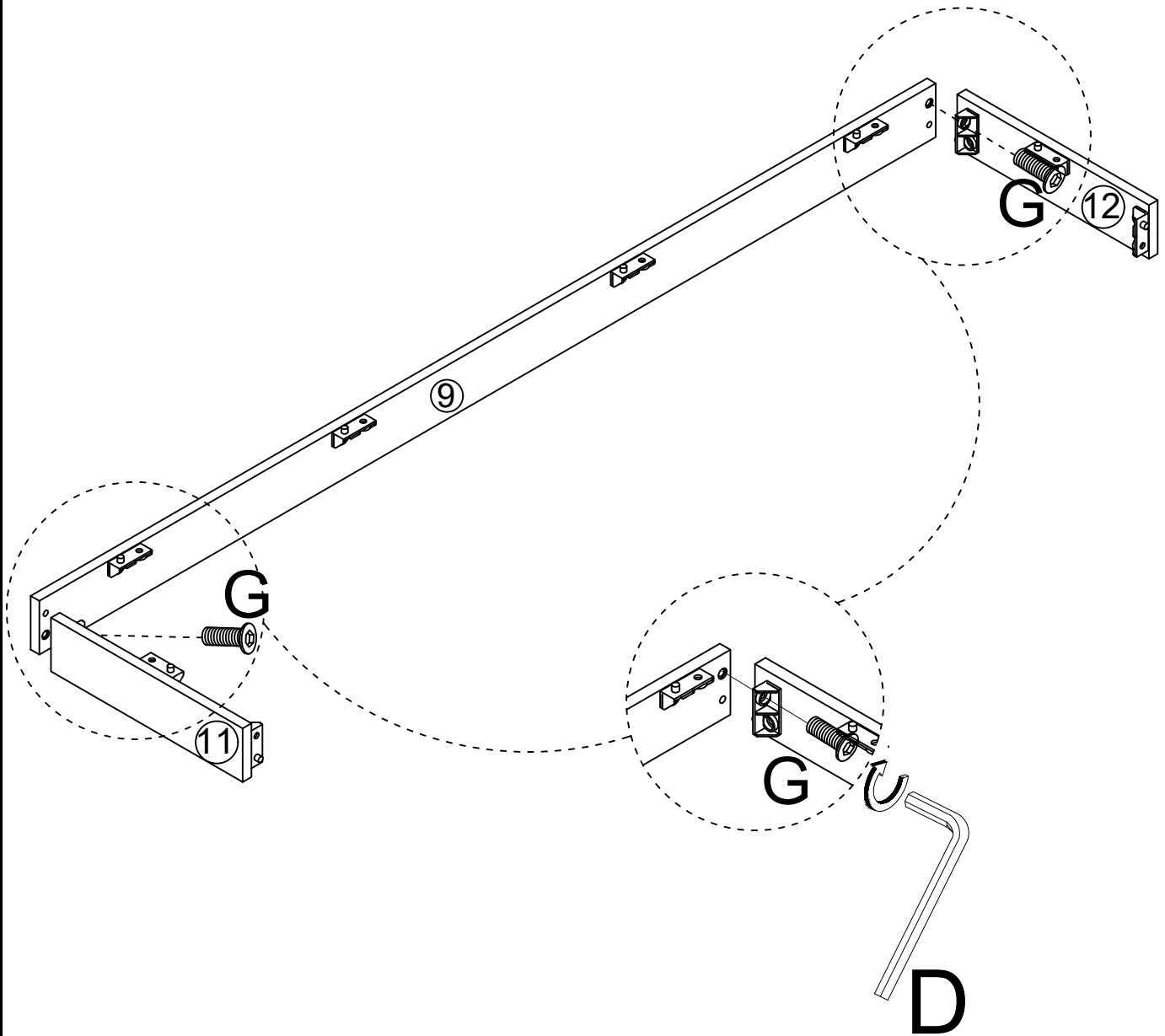

Step 10

G	D
	
X2	X1



Step 11

G	D
	
X2	X1

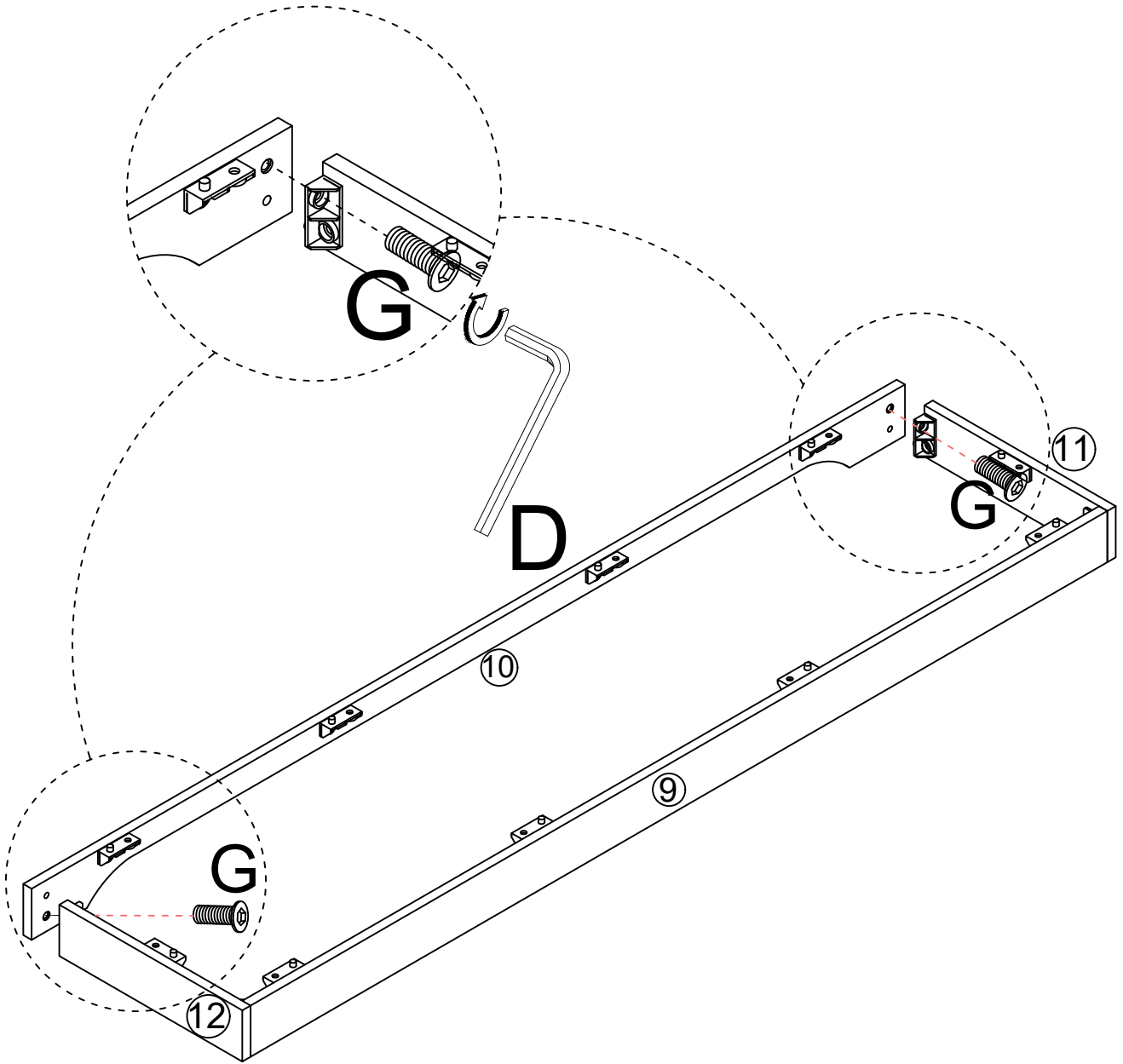

Step 13

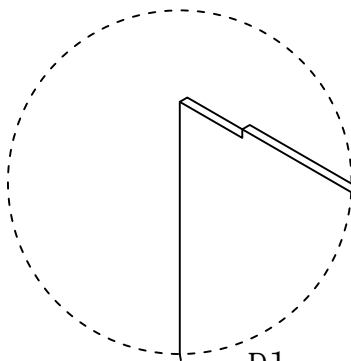

Please make sure ,the notch on the part(2) is upside as the drawing show.

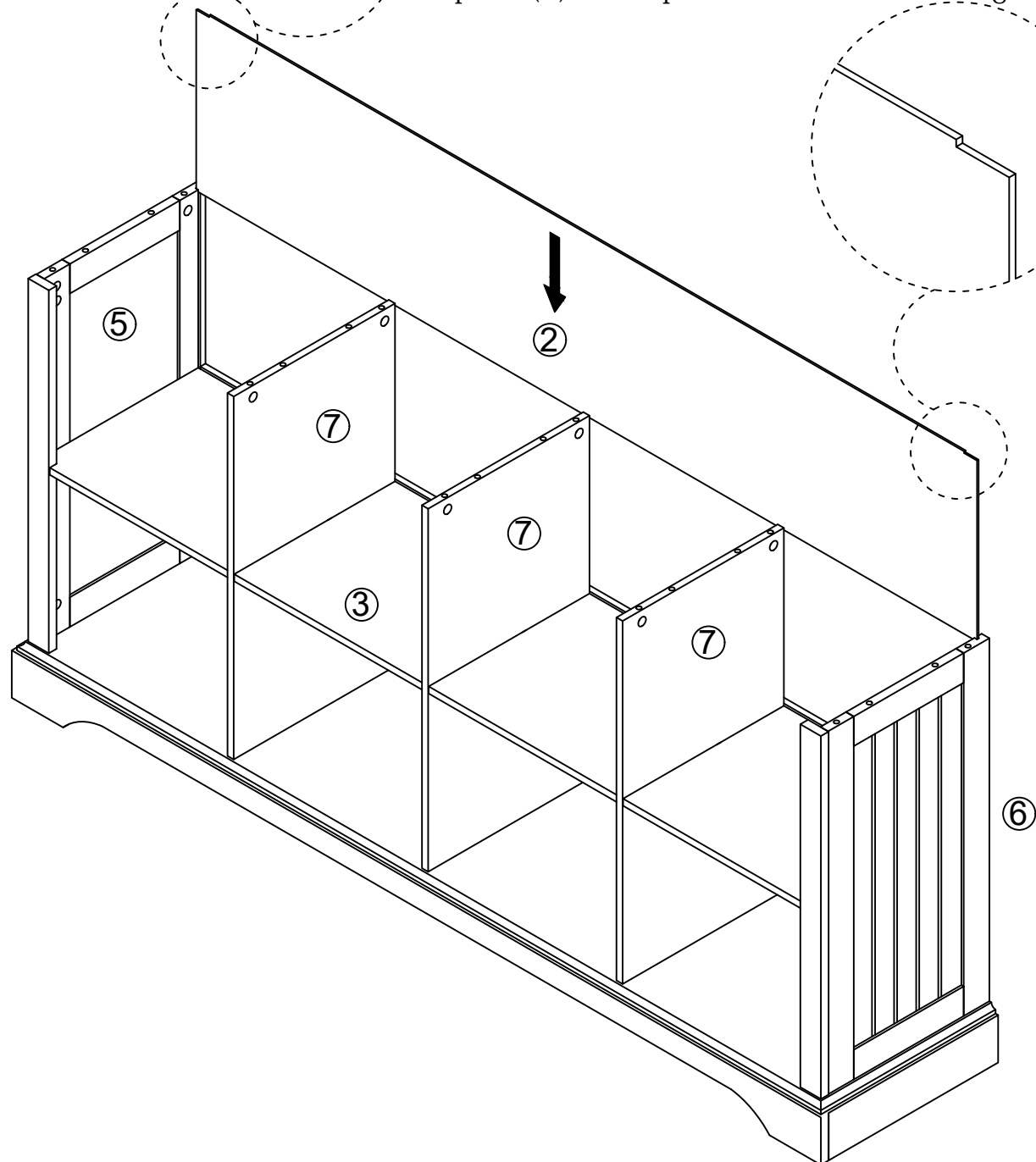
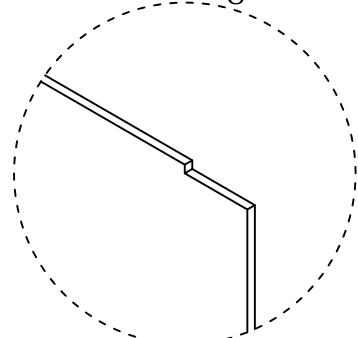

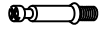

Step 14

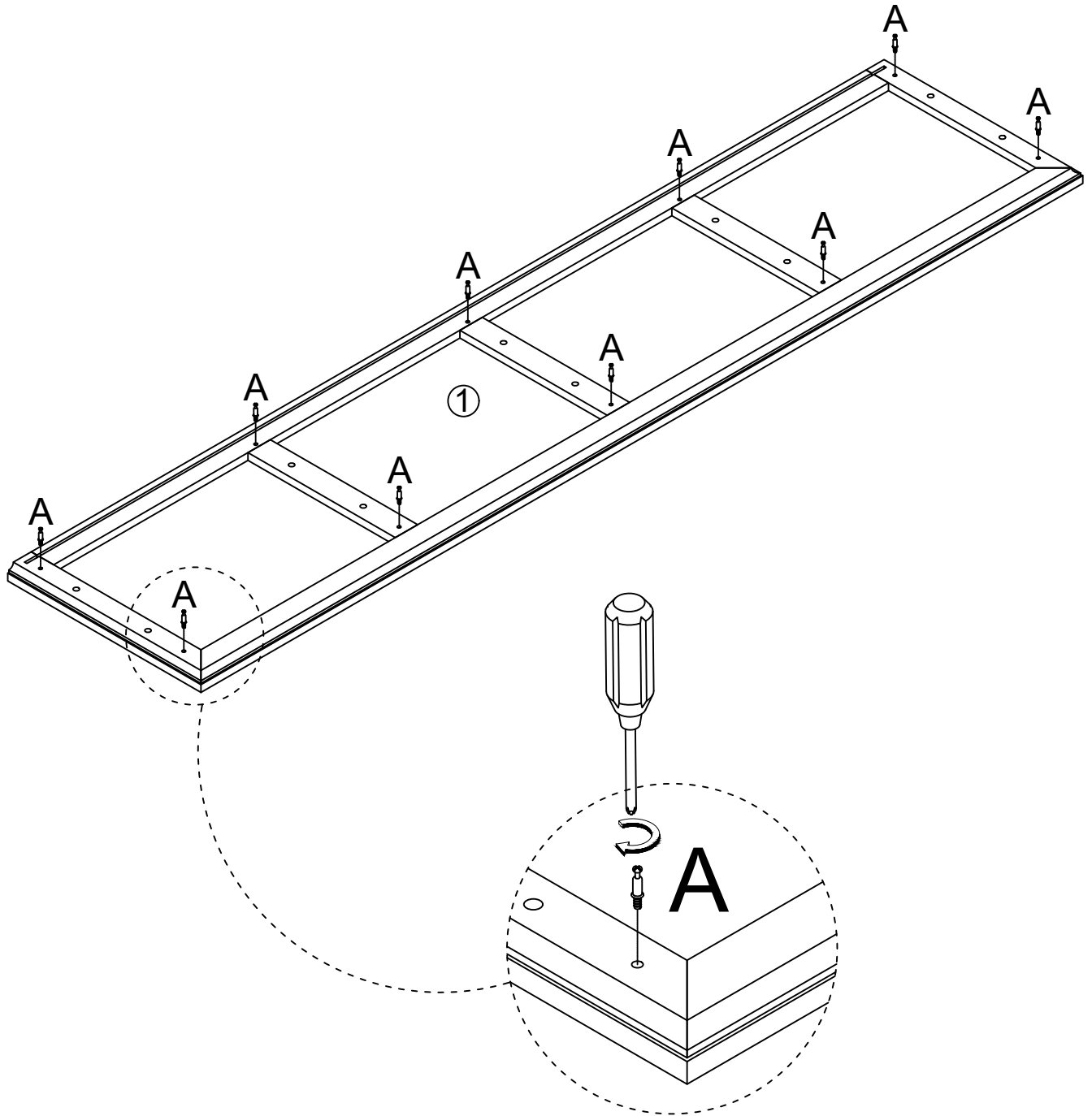
A

X10

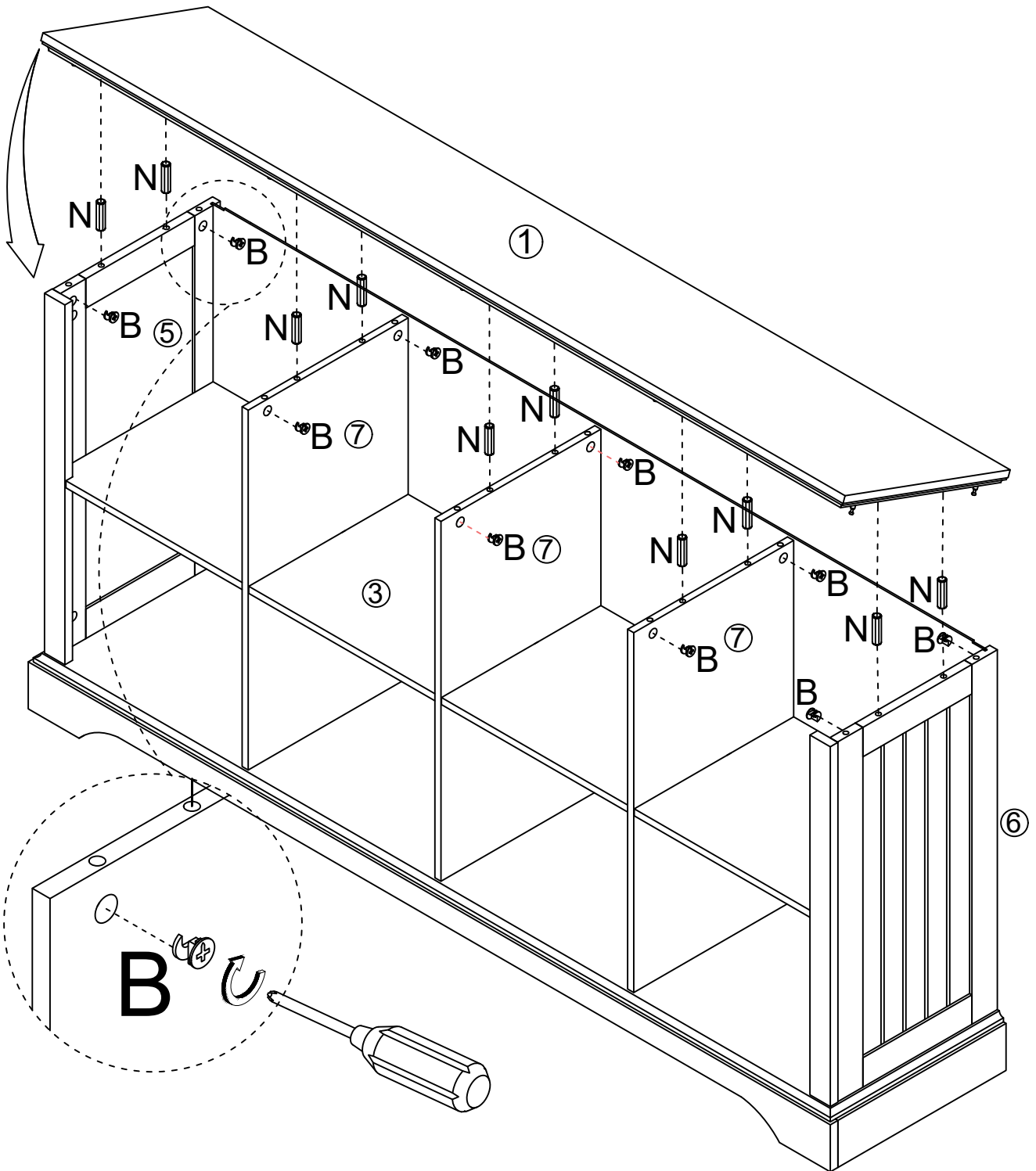

Step 15

N	B
	
X10	X10



Step 16

o



O

X18

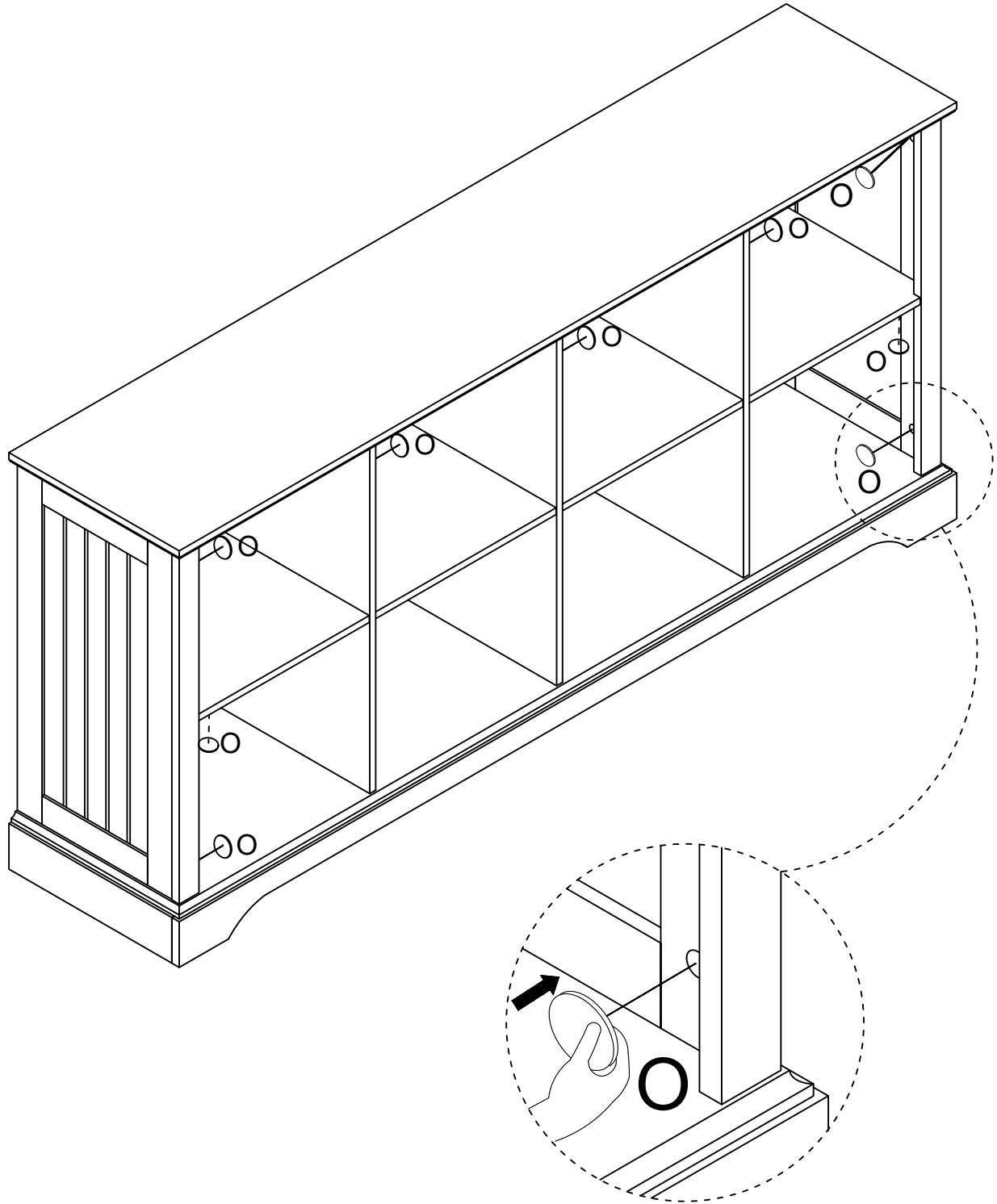
Notice: Covered all the cam lock holes with the sticker(O)



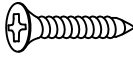

Step 17

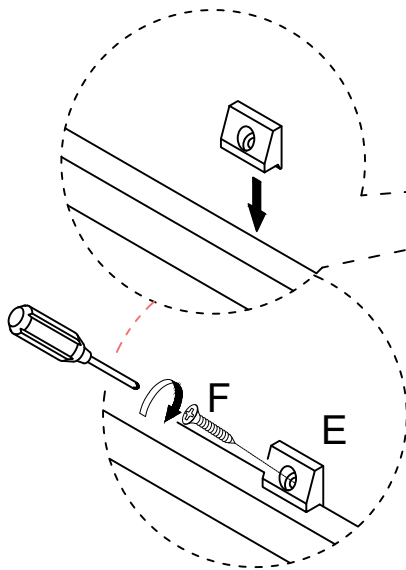
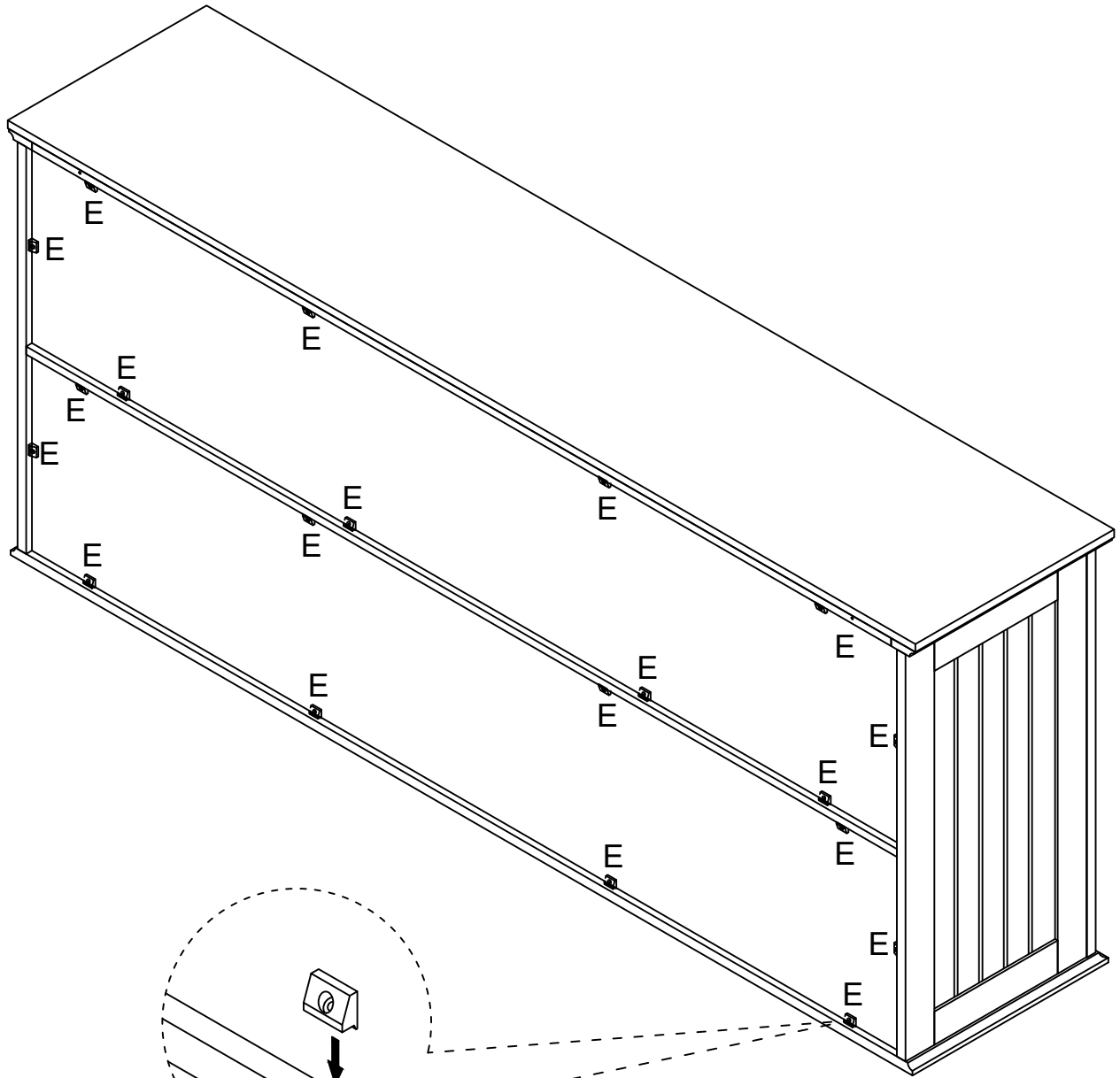
F	E
	
X20	X20

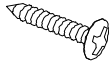

Step 18

J	K
	
X2	X2

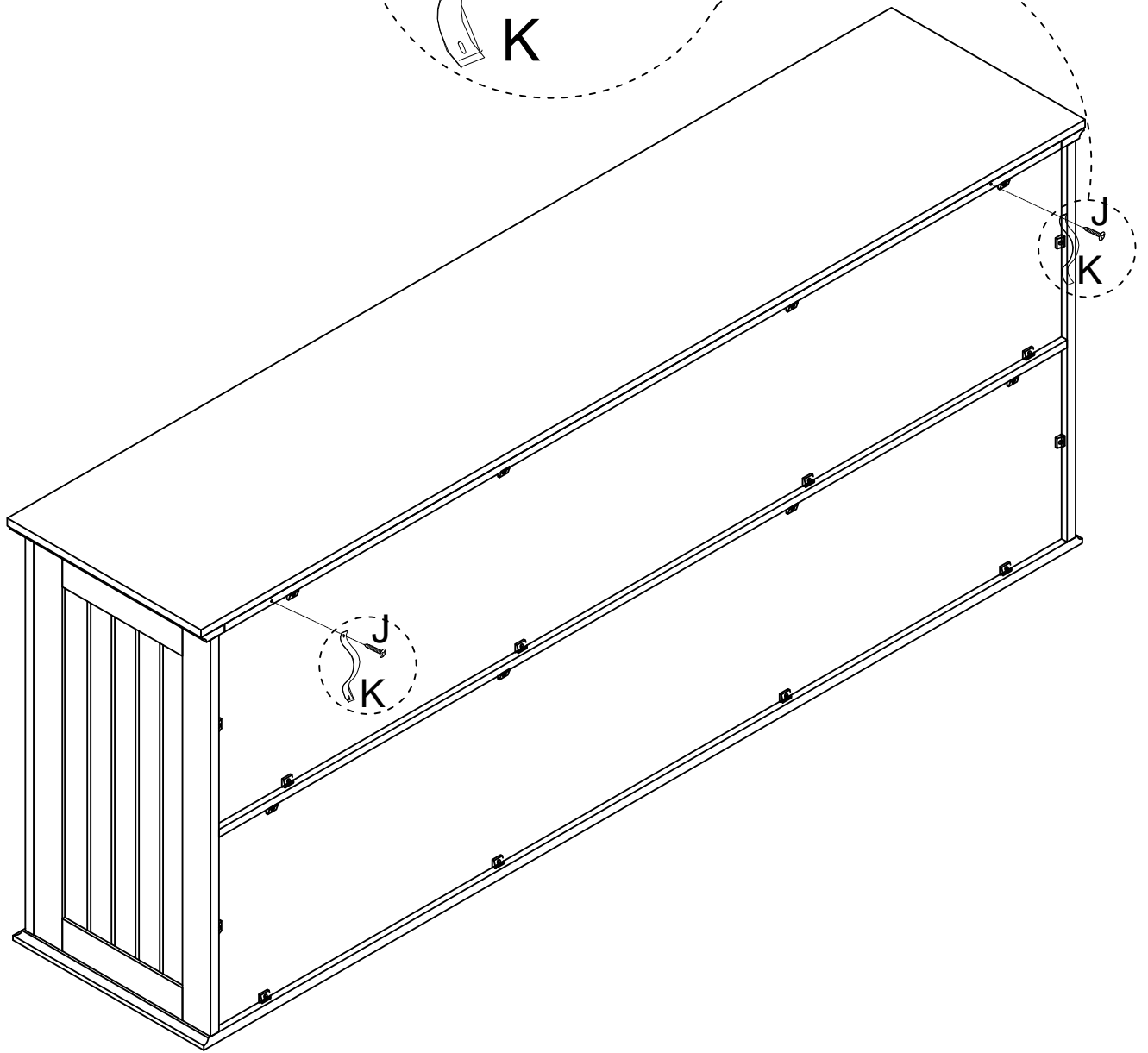
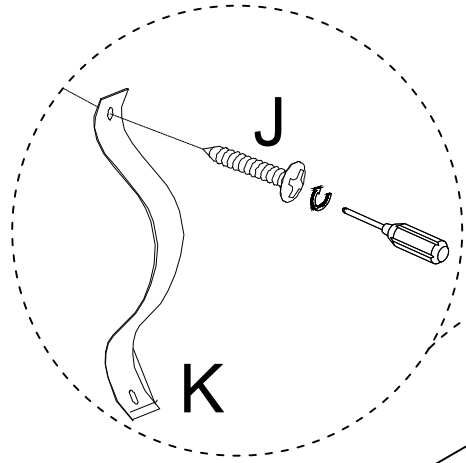

Step 19

Make TWO holes 45MM deep

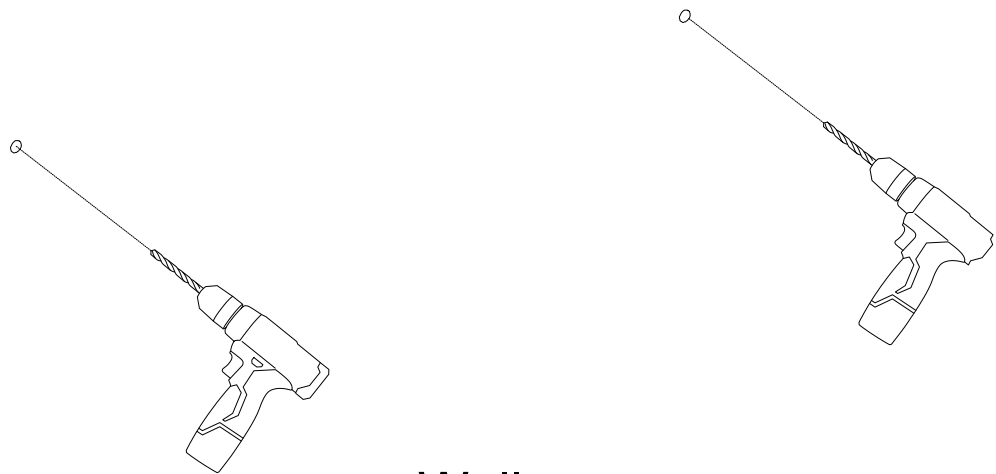

Wall

Step 20

L

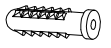

X2

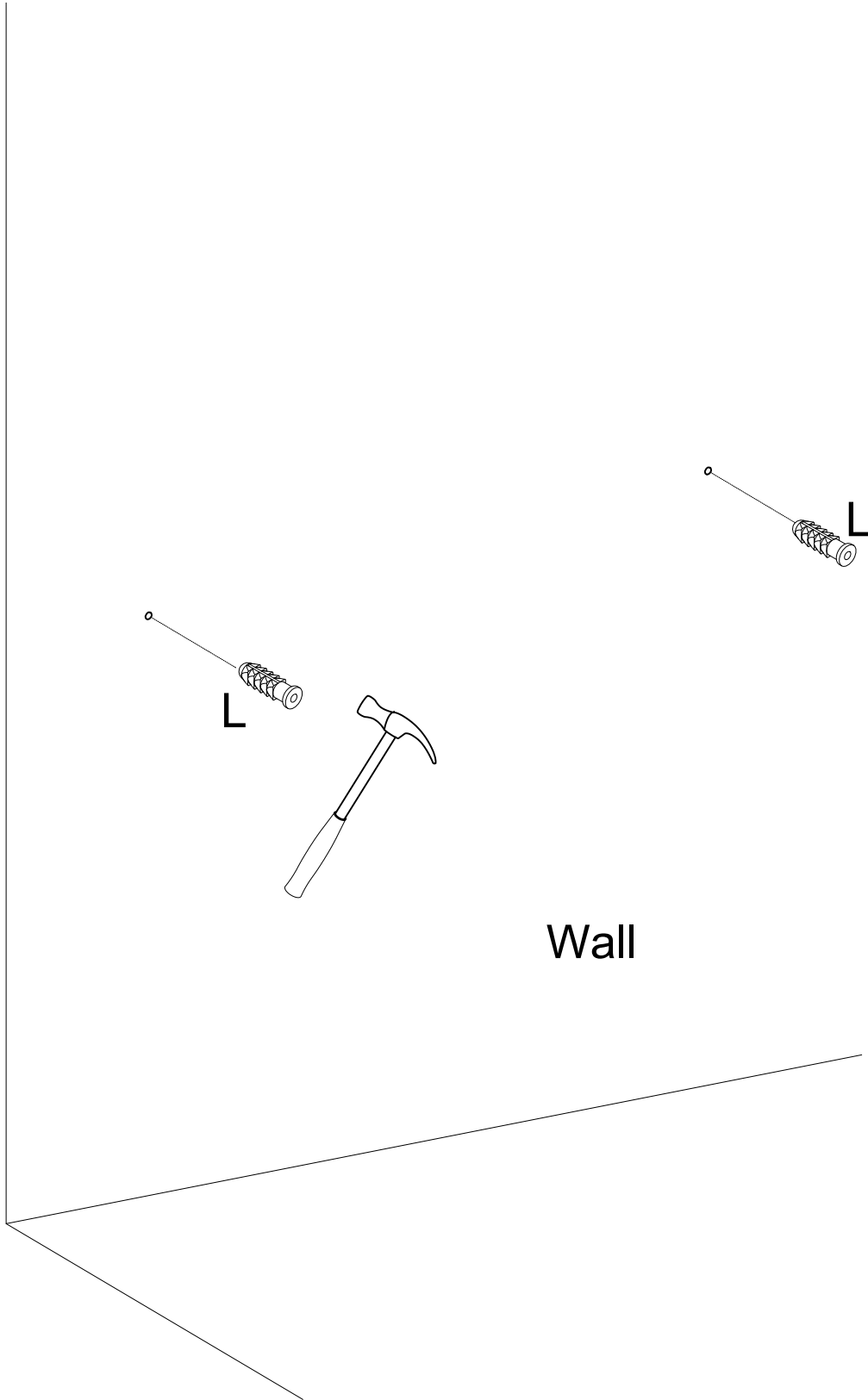

Step 21

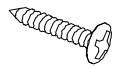
I

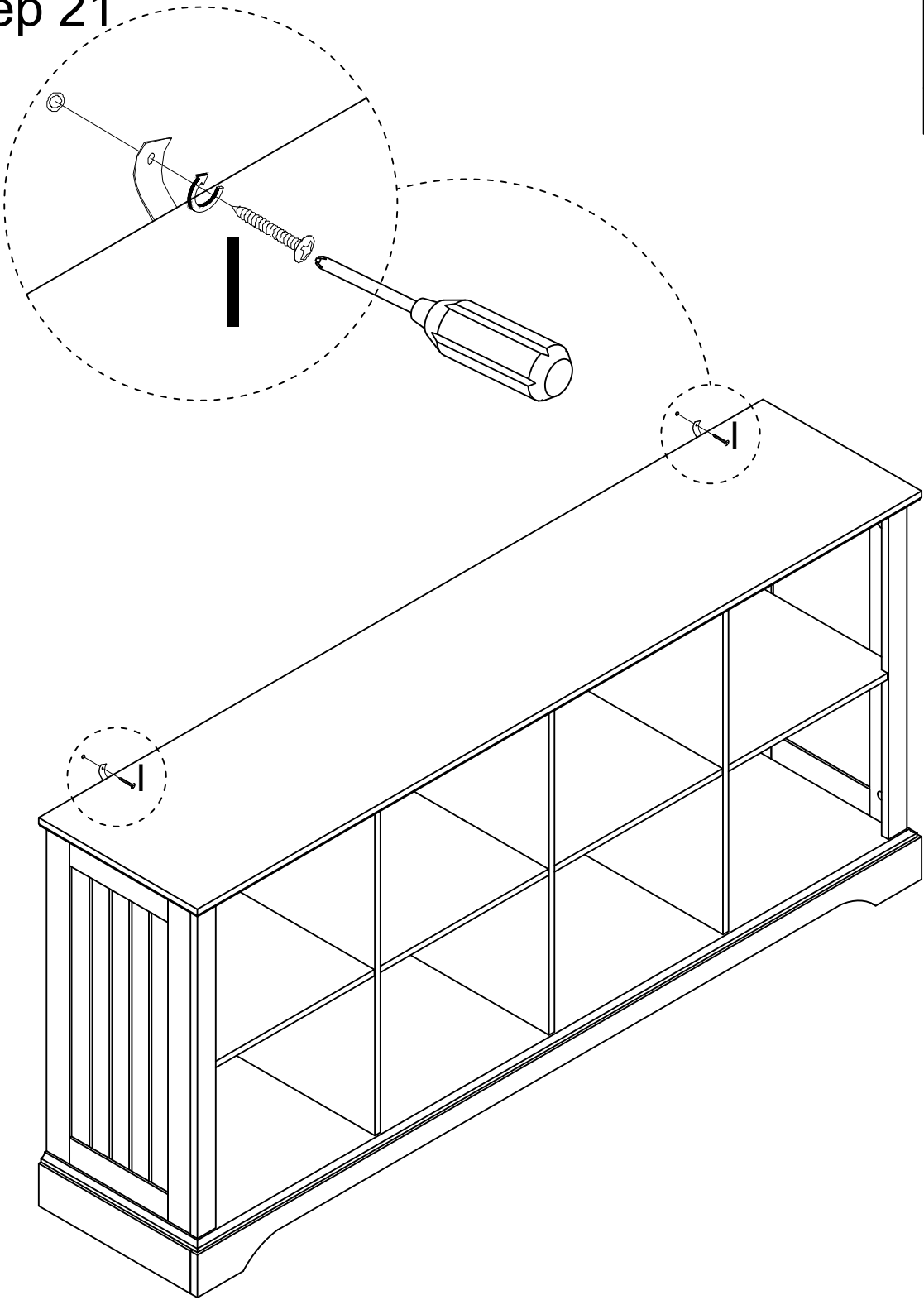
X2

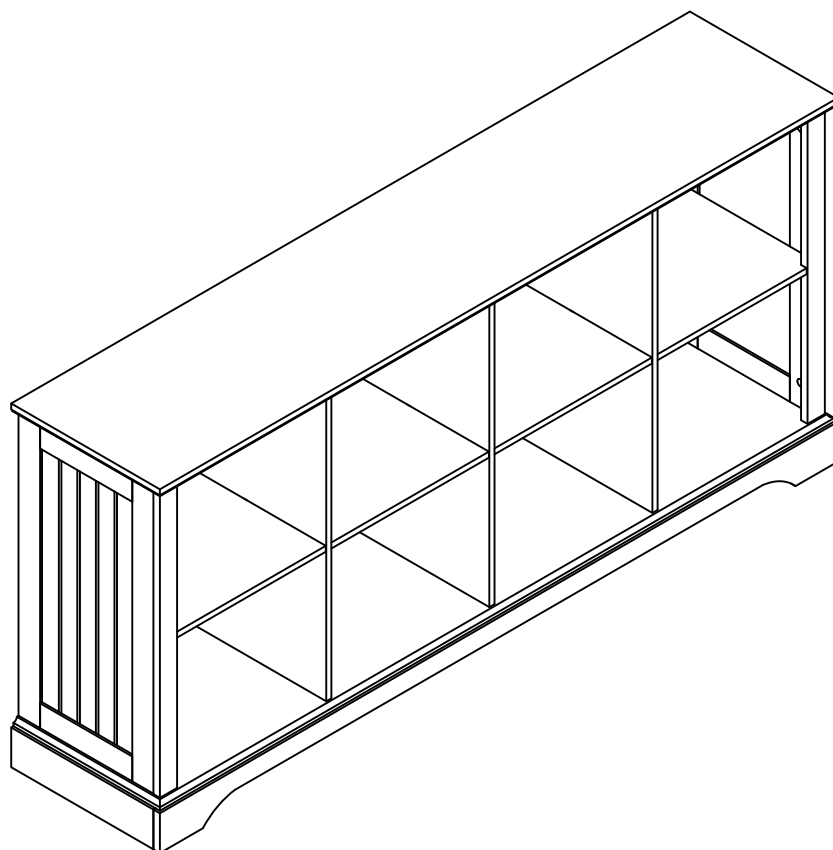

Step 22



Step 23



WARNING



Children have died from furniture tipover. To reduce the risk of furniture tipover:

- ALWAYS install Anti-tip device provided.
- NEVER put a TV on this product.
- NEVER allow children to stand, climb or hang on drawers, doors, or shelves.
- NEVER open more than one drawer at a time.
- Place heaviest items in the lowest drawers.

