

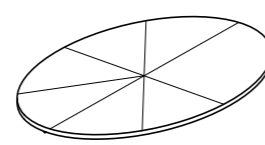

ASSEMBLY INSTRUCTION



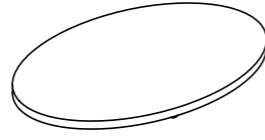

DESCRIPTION OVAL COCKTAIL TABLE

Thank you for purchasing this quality product. Be sure to check all packing material carefully for small parts, which may have come loose inside the carton during shipment. Identify and count all parts and compare with the parts list below.

PARTS LIST

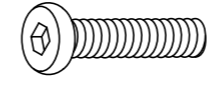
NO	SKETCH	DESCRIPTION	Q'TY
1		Table Top	1pc
2		Side Panels	2pcs
3		Shelf	1pc

HARDWARE LIST

NO	SKETCH	DESCRIPTION	SIZE	Q'TY
A		Bolt	5/16"x35mm	12pcs
B		Spring Washer	5/16"	12pcs
C		Flat Washer	5/16"x16x2mm	12pcs
D		Allen Key	4mm	

STEP 1

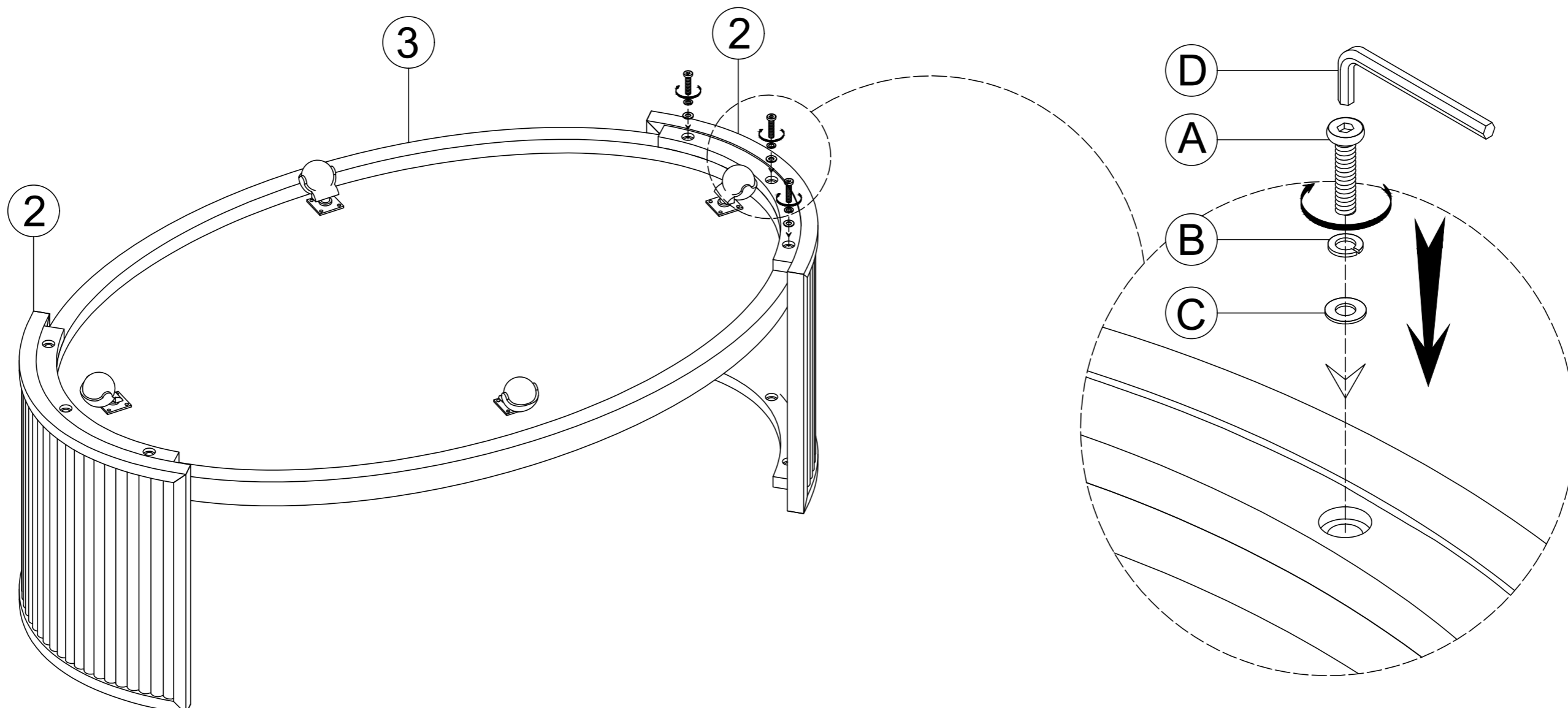

STEP 2

