

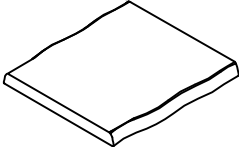

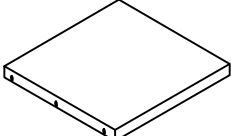

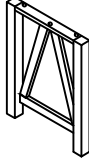

ASSEMBLY INSTRUCTION

END TABLE

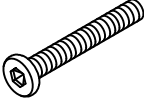
A Top Panel  1pc	B Bottom Panel  1pc	C Leg  2pcs	D Bolt Ø1/4"x1-1/4"  6pcs
E Bolt Ø1/4"x2-1/2"  6pcs	F Lock Washer Ø1/4"  12pcs	G Flat Washer Ø1/4"x19mm  12pcs	H Allen Key M4  1pc

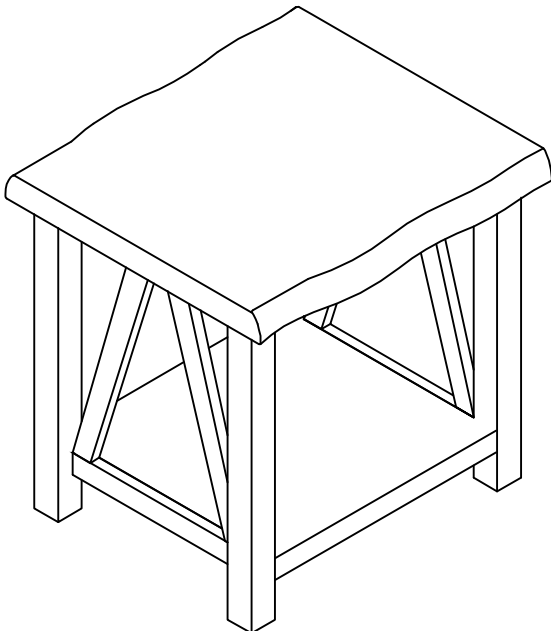

This page lists all the contents included in the box. Please take the time to identify the hardware as well as the individual components to this product. As you unpack and prepare for assembly, place the contents on a carpeted or padded area to protect them from damage.

- 1** Put Top Panel (A) on a smooth felt surface, face down, assemble Leg (C) to the Top Panel (A), using Bolt (D), Lock Washer (F), Flat Washer (G) by Allen Key (H). Do not tighten the bolts at this step.

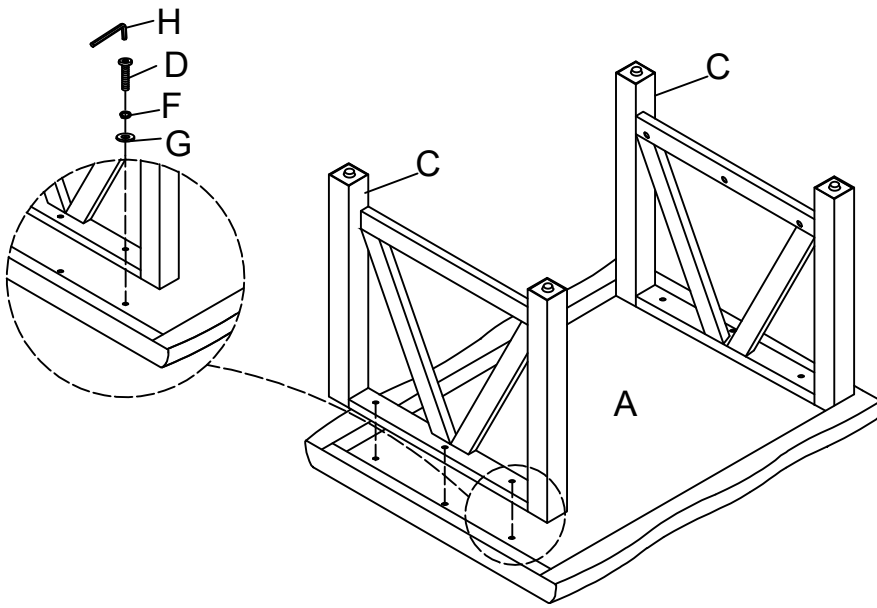

- 2** Assemble Bottom Panel (B) to the Leg (C) using Bolt (E), Lock Washer (F), Flat Washer (G) by Allen Key (H). After all bolts assembled in, tighten all bolts and finish the table assembly. Upside the table.

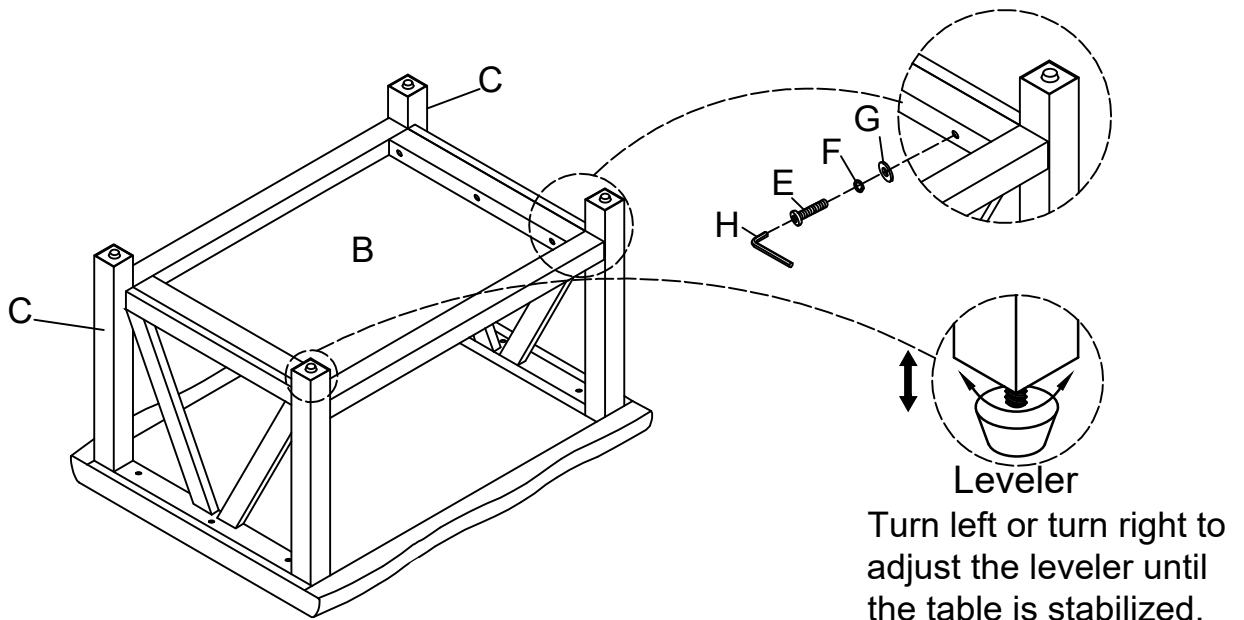

Cleaning & Care

Treat surface with care. Surface is resistant to scratches but is not scratch resistant. Clean surfaces with a dry or damp soft cloth. Do not use abrasive cleaners. Hardware may loosen over time. Periodically check that all connections are tight.