

# ASSEMBLY INSTRUCTIONS

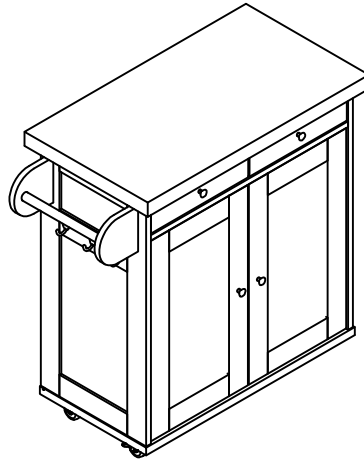

## IMPORTANT PLEASE READ BEFORE YOU CONTINUE FURTHER

### WARNING AND INSTRUCTIONS

#### GENERIC

- IMPORTANT: RETAIN THESE INSTRUCTIONS FOR FUTURE REFERENCE.
- DUE TO THE SIZE OF THIS PRODUCT WE RECOMMEND THAT IT IS ASSEMBLED IN THE ROOM INTENDED FOR USE.
- WHEN YOU ARE READY TO START, MAKE SURE THAT YOU HAVE THE RIGHT TOOLS, PLENTY OF SPACE AND A CLEAN, DRY AREA FOR ASSEMBLY.
- UNWRAP ALL PACKAGING MATERIALS AND PLACE THE COMPONENTS ON TOP OF THE CARTON BOX OR ON A CLEAN FLOOR TO PREVENT IT FROM SCRATCHING.
- CHECK THE PACK AND MAKE SURE YOU HAVE ALL THE PARTS LISTED.
- ENSURE THAT THIS PRODUCT IS FULLY ASSEMBLED AS ILLUSTRATED BEFORE USE.
- TOOLS NOT INCLUDED.
- CHECK ALL SCREWS OR BOLTS ARE TIGHTENED AND INSPECT REGULARLY.
- THIS PRODUCT SHOULD ONLY BE USED ON FIRM LEVEL GROUND.
- KEEP SMALL PART OUT OF REACH OF CHILDREN.
- MAKE SURE THE LEGS REMAIN IN CONTACT WITH THE GROUND.
- DO NOT USE POWER TOOLS TO CONSTRUCT THIS PRODUCT.
- DO NOT TIGHTENED SCREWS UNTIL FULLY ASSEMBLED.
- DO NOT OVER TIGHTENED SCREWS OR BOLTS.
- DO NOT USE THIS PRODUCT IF PARTS ARE MISSING, DAMAGE OR WORN.
- DO NOT SIT AND STAND ON THE PRODUCT.
- TO CLEAN WIPE WITH A SPONGE AND WARM SOAPY WATER. DO NOT USE SOLVENT BASED CLEANERS OR DETERGENTS AS THEY CAN BLEACH OR DAMAGE THE PRODUCT.
- NEVER USE SCOURERS, ABRASIVES OR CHEMICAL CLEANERS.

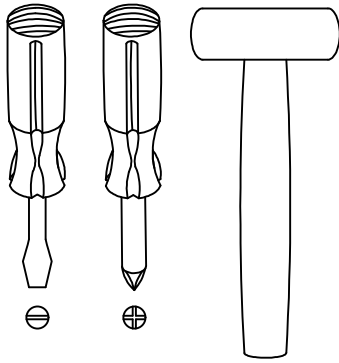

(Tools not provided)

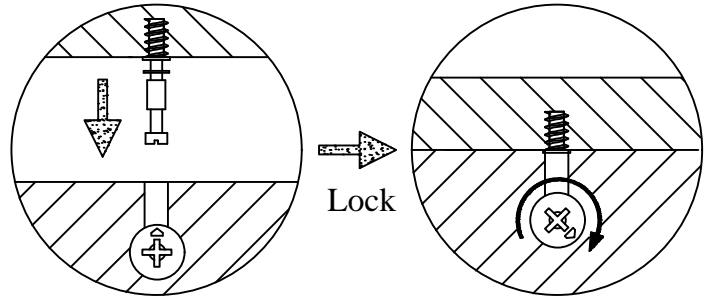

Use a flat blade screwdriver to tighten the cam nuts. A quarter turn clockwise is all that is needed.

## This is how a cam nut works.....

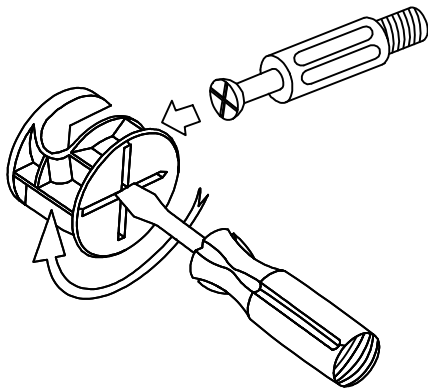

The head of the cam bolt goes into the open mouth of the cam nut. You then turn the cam nut so it tightens over the bolt.

### TWO PERSONS REQUIRED TO ASSEMBLE THIS PRODUCT

1. Please check that you have all the parts listed before you start assembling. If you do find that something is missing, do not continue assembly. Please contact your supplier immediately.
2. Lay out all of the components on a soft surface as if you were preparing to do a jigsaw puzzle.
3. Separate and identify each component from the hardware pack and rest each one in its proper location before fastening.

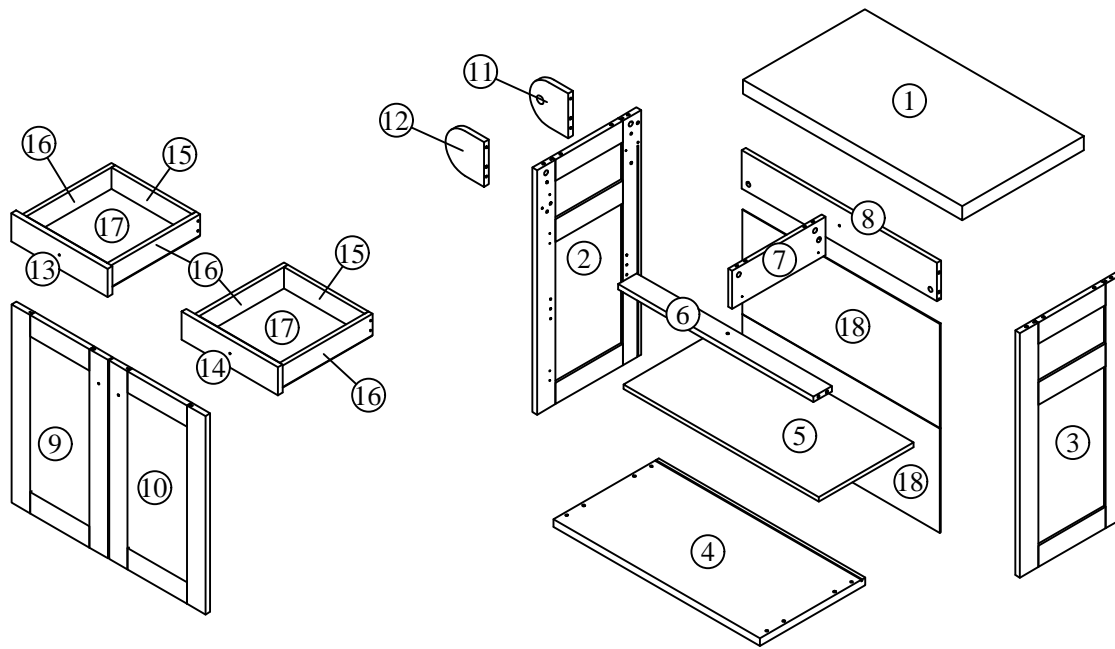

## PARTS LIST

NO	PARTS					QTY
1	828	x	460	x	46	1 pc
2	800	x	394	x	18	1 pc
3	800	x	394	x	18	1 pc
4	780	x	398	x	25	1 pc
5	738	x	358	x	15	1 pc
6	738	x	70	x	18	1 pc
7	353	x	125	x	15	1 pc
8	738	x	125	x	15	1 pc
9	649	x	364	x	18	1 pc
10	649	x	364	x	18	1 pc
11	146	x	146	x	18	1 pc
12	146	x	146	x	18	1 pc
13	364	x	92	x	18	1 pc
14	364	x	92	x	18	1 pc
15	305	x	70	x	15	2 pcs
16	350	x	70	x	15	4 pcs
17	334	x	350	x	3	2 pcs
18	747	x	341	x	3	2 pcs

## HARDWARE LIST

NO.	DESCRIPTION		QTY
A		WOOD DOWEL 8 x 30mm	16
B		M4 x 16mm CSK SCREW	60
C		M4 x 38mm CSK SCREW	16
D		M6 x 50mm JCBCW SCREW	5
E		M6 x 60mm JCBCW SCREW	4
F		ALLEN KEY M6	1
G		CAM FITTING (15mm)	11
H		SCREW - IN DOWEL	11
I		MINI FIX - CAP	11
J		HANDLE 702-25	4
K		M4 x 22mm T/MS SCREW	2
L		M4 x 35mm T/MS SCREW	2
M		METAL SHELF SUPPORT	4
N		HINGES 7/8	4
O		NAIL	20
P		HANGER V93-S	3
Q		NYLON CASTOR 50MM(W/O STOPPER)	2
R		NYLON CASTOR 50MM(WITH STOPPER)	2
S		METAL RUNNER 14"	2
T		H-LINING (736MM)	1
U		CHROME PIPE Ø25 - 319MM	1

THE USE OF POWER TOOLS TO ASSEMBLE THIS PRODUCT WILL INVALIDATE ANY CLAIM AND MAY DAMAGE THIS PRODUCT MAKING IT UNSAFE.



# STEP 1

A		WOOD DOWEL 8 x 30mm	16
B		M4 x 16mm CSK SCREW	10
G		CAM FITTING (15mm)	11
H		SCREW - IN DOWEL	11
S		METAL RUNNER 14"	2



# STEP 2

B		M4 x 16mm CSK SCREW	12	L		M4 x 35mm T/MS SCREW	2
C		M4 x 38mm CSK SCREW	16	O		NAIL	20
J		HANDLE	2	S		METAL RUNNER 14"	2

THE USE OF POWER TOOLS TO ASSEMBLE THIS PRODUCT WILL INVALIDATE ANY CLAIM AND MAY DAMAGE THIS PRODUCT MAKING IT UNSAFE.





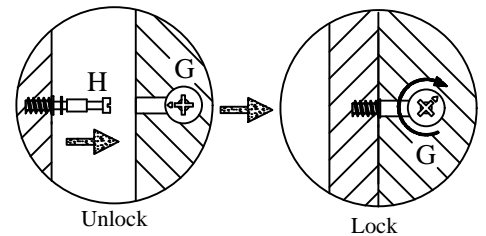
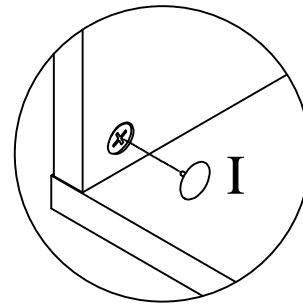
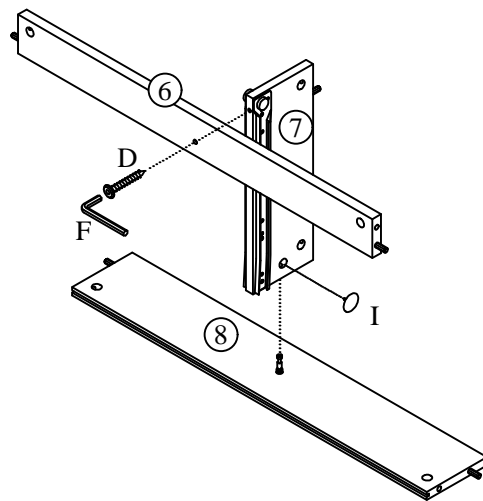

### STEP 3

D		M6 x 50mm JCBCW SCREW	1
F		ALLEN KEY M6	1
I		MINI FIX - CAP	1



### STEP 4

B		M4 x 16mm CSK SCREW	6
D		M6 x 50mm JCBCW SCREW	4
F		ALLEN KEY M6	1
U		CHROME PIPE Ø25 - 319MM	1
P		HANDER V93-S	3

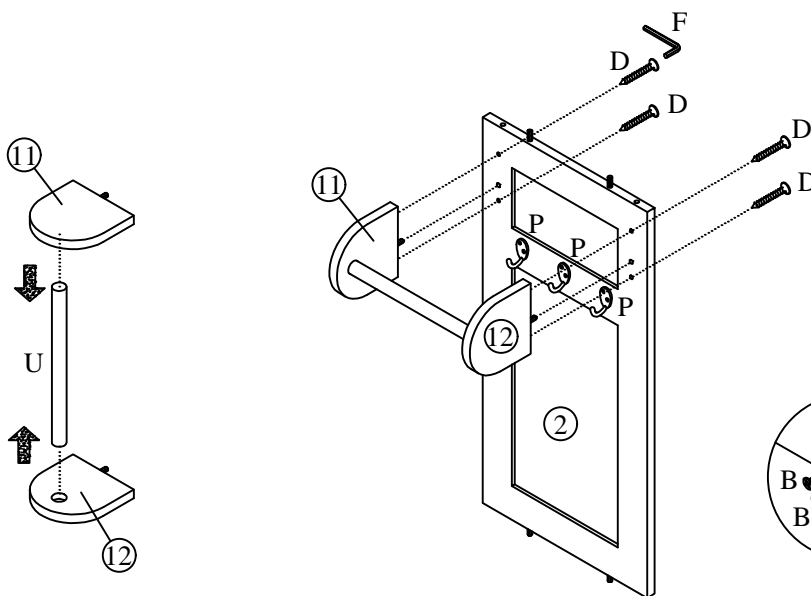

THE USE OF POWER TOOLS TO ASSEMBLE THIS PRODUCT WILL INVALIDATE ANY CLAIM AND MAY DAMAGE THIS PRODUCT MAKING IT UNSAFE.



# STEP 5

I		MINI FIX - CAP	4
---	---	----------------	---

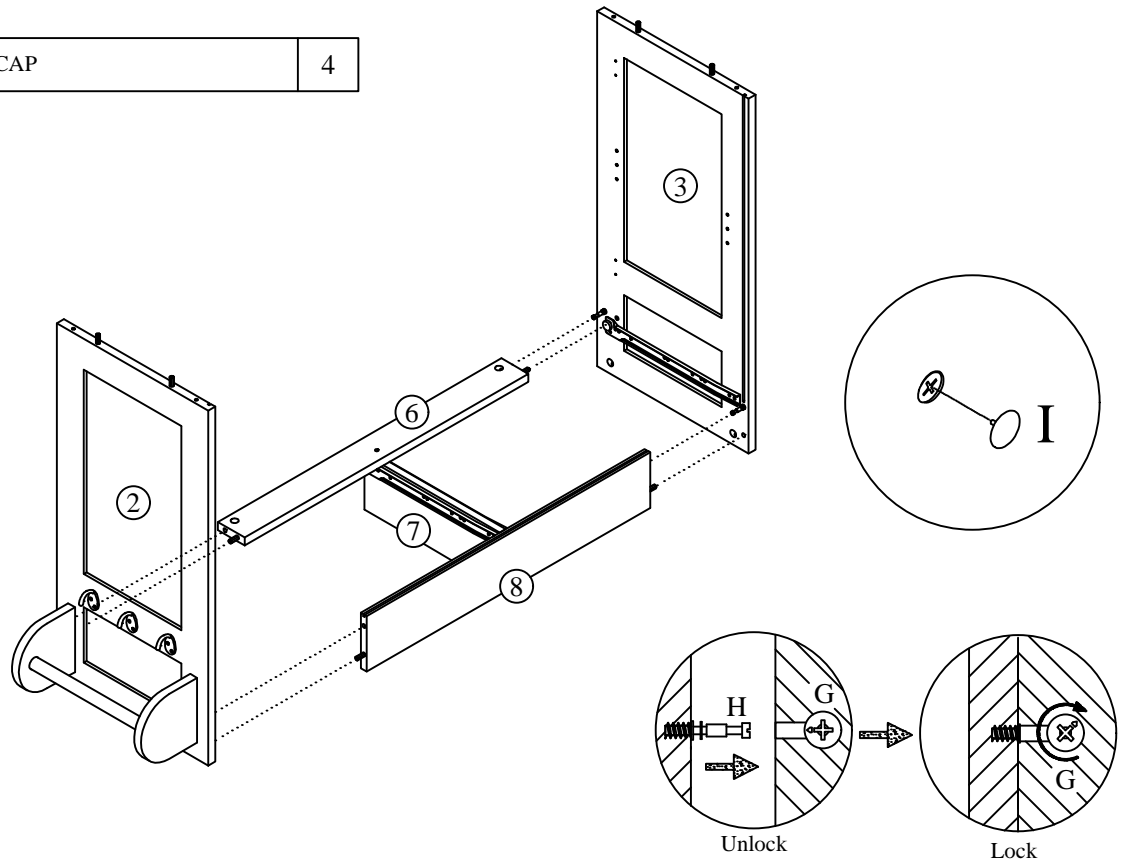

# STEP 6

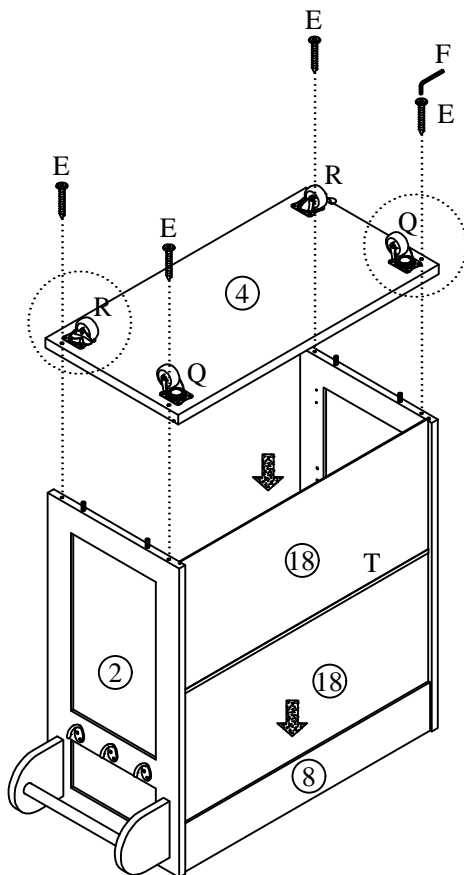

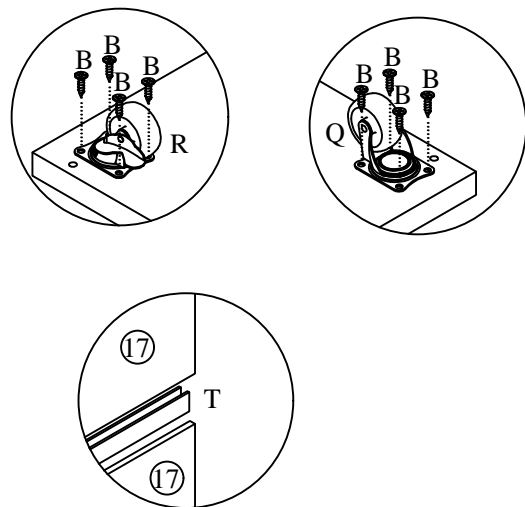

B		M4 x 16mm CSK SCREW	16
E		M6 x 60mm JCBCW SCREW	4
F		ALLEN KEY M6	1
Q		NYLON CASTOR 50MM (W/O STOPPER)	2
R		NYLON CASTOR 50MM(WITH STOPPER)	2
T		H-LINING (736MM)	1



THE USE OF POWER TOOLS TO ASSEMBLE THIS PRODUCT WILL INVALIDATE ANY CLAIM AND MAY DAMAGE THIS PRODUCT MAKING IT UNSAFE.



# STEP 7

I		MINI FIX - CAP	6
M		METAL SHELF SUPPORT	4

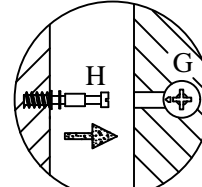
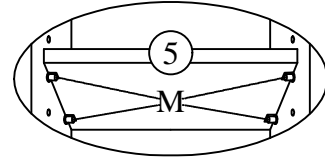
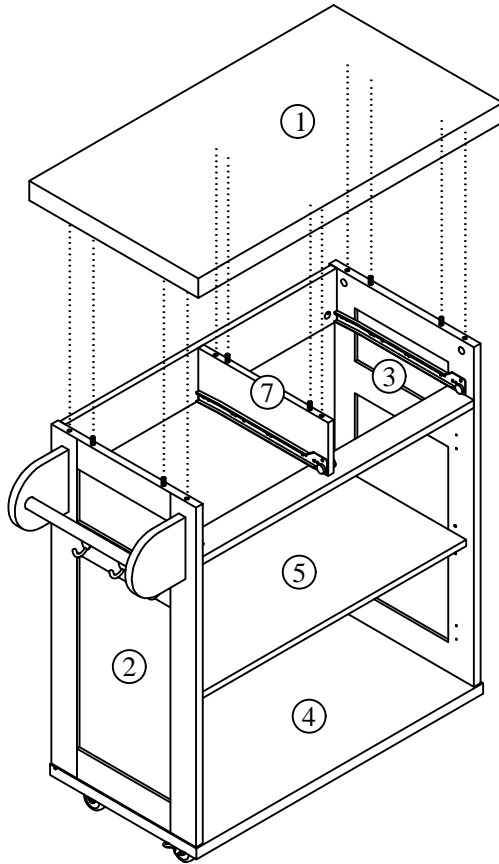

Unlock

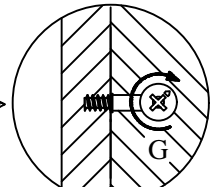

Lock

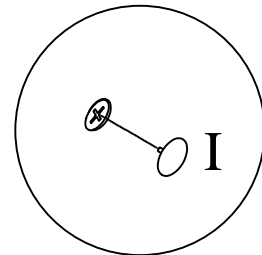



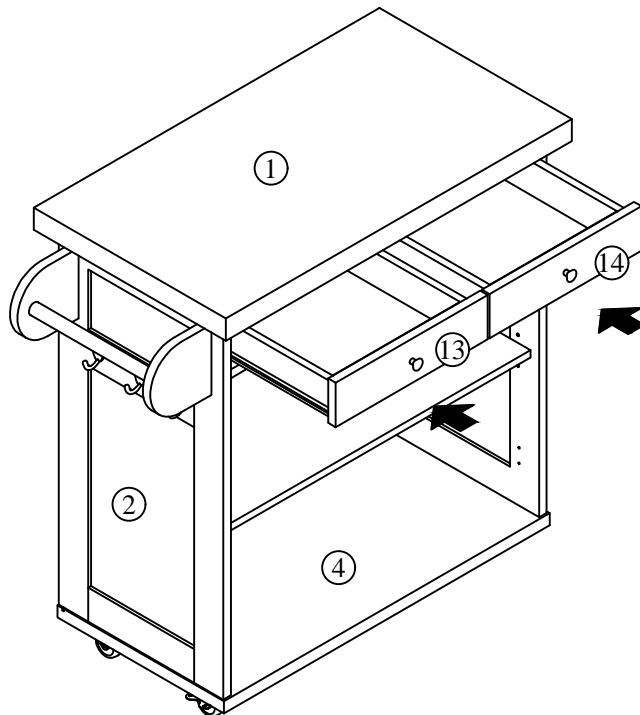

# STEP 8



THE USE OF POWER TOOLS TO ASSEMBLE THIS PRODUCT WILL INVALIDATE ANY CLAIM AND MAY DAMAGE THIS PRODUCT MAKING IT UNSAFE.



## STEP 9

B		M4 x 16mm CSK SCREW	16
J		HANDLE 702-25	2
K		M4 x 22mm T/MS SCREW	2
N		HINGES 7/8	4

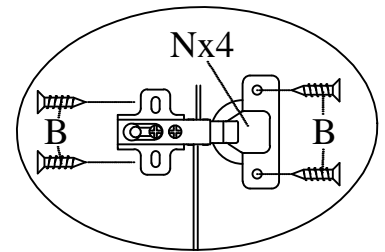
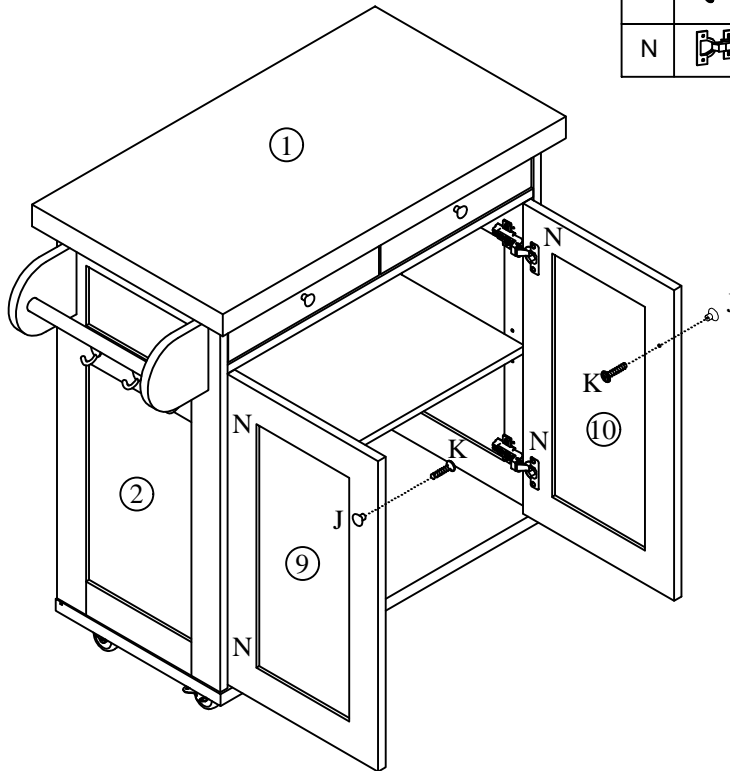

## STEP 10

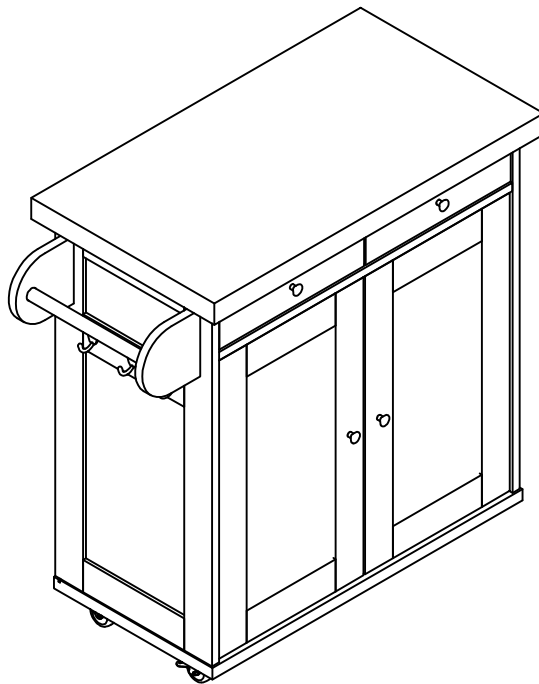

THE USE OF POWER TOOLS TO ASSEMBLE THIS PRODUCT WILL INVALIDATE ANY CLAIM AND MAY DAMAGE THIS PRODUCT MAKING IT UNSAFE.

