

ASSEMBLY & INSTRUCTION

- **Twin/XL**

[CLICK HERE](#)

Size: 75"L×38"W/ 80"L×38"W

- **Full/Queen**

[CLICK HERE](#)

Size: 75"L×54"W/80"L×60 W

- **King /CK**

[CLICK HERE](#)

Size: 76"L×80"W/ 72"L×84"W

-



[Back to Top](#)

ASSEMBLY INSTRUCTION

Box Spring

Size: Twin/Twin XL (01/02)

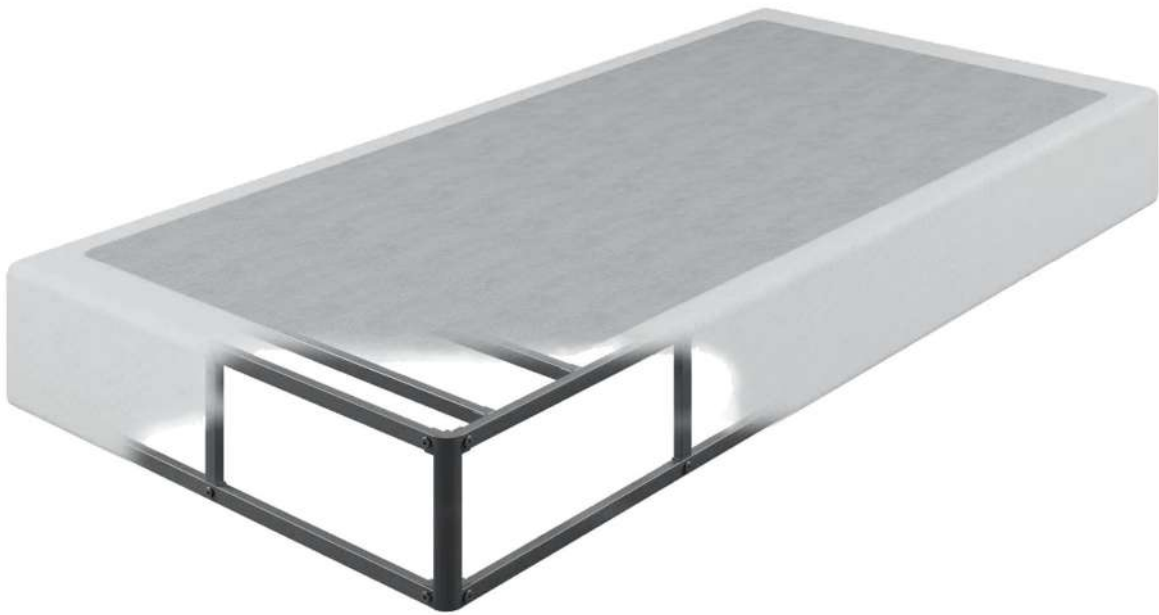













★ You can contact us via the marketplace [order message center](#) for any product questions. We will reply within 24 hours. Thanks for your support!

★ In case of missing or damaging parts, please provide your order number and the name of the required part to apply for a replacement.

★ Power tools **are prohibited** for installation, as they may cause thread stripping.

★ **Do not full tighten any screws until the entire assembly is completed.** This allows for proper alignment and adjustments during the assembly process. Tightening them all at the end will result in a more stable structure.

			
②×4 Bedhead Bracket	④×1 Center Support Bar	⑤×2 Side Bracket	⑥×6 Side Rail
			
⑦×4 Bed Post	⑧×8 Slat	⑨×1 Bed Cover	⑩×2 Special Slat

Tool	Pre-Assembly	STEP 1	STEP 2	Spare A×1 B×1
				
H×1 4mm	B×20 M6*19	B×8 M6*19	A×2 M6*30	

Legend: ② x4 means Part No.② , 4 pieces.

M6*30 means an M6 - sized screw with a length of 30mm.

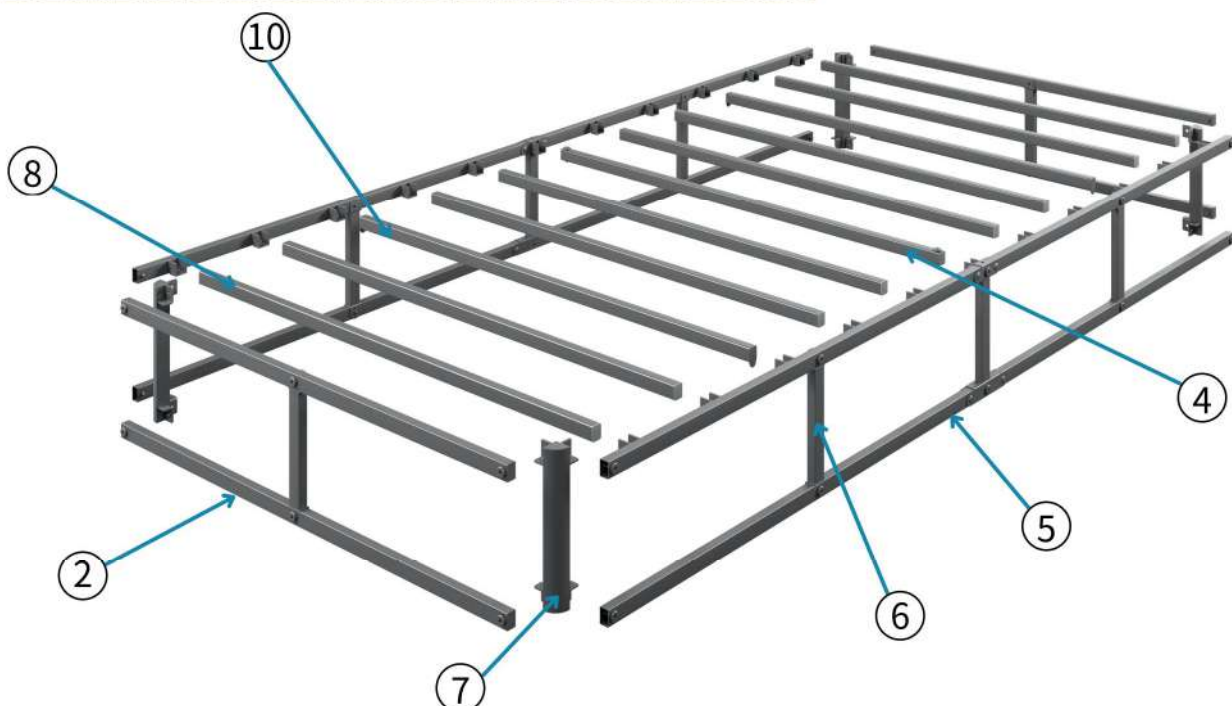

★ This product only includes the parts numbered above, and the missing numbers are not used in this product.

Pre-Assembly

1. Connect part ② and ⑥ with screws B, creating 2 assembled parts called "HS".

②×4 Bedhead Bracket

⑥×2 Side Rail

B×4 M6*19 

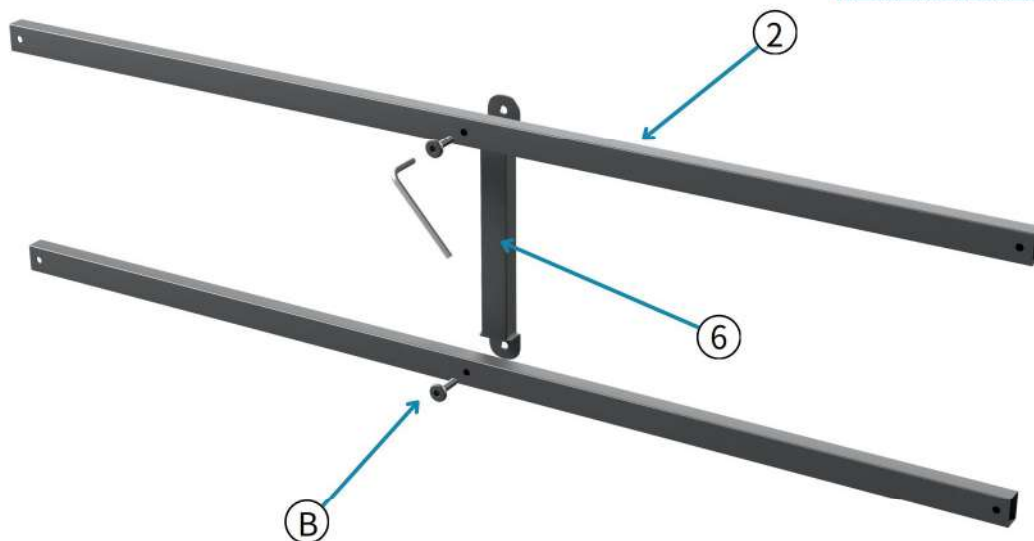

2: Connect part ⑤ and ⑥ with screws B;
Then joint part ⑦ with screws B as shown, creating 2 assembled parts called "SS".

⑤×2 Side Bracket

⑥×4 Side Rail

⑦×4 Bed Post

B×16 M6*19 

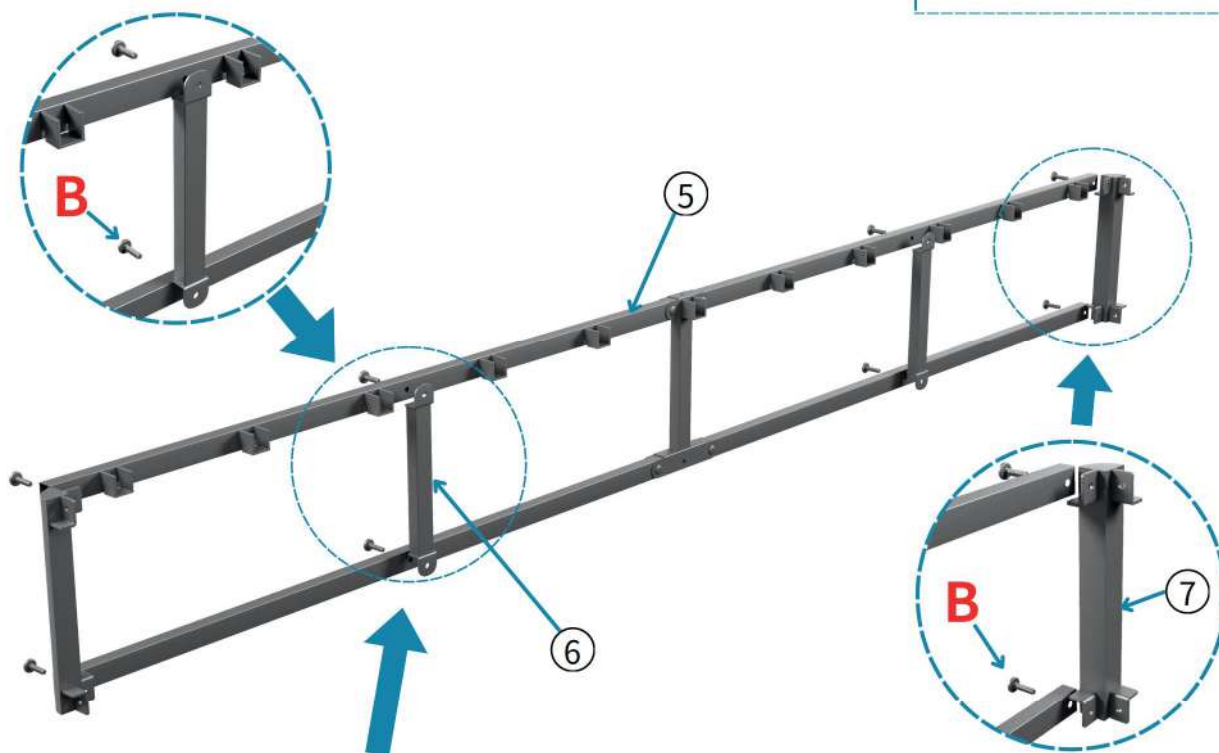

The metal plate of the side support is secured to the bracket from the inside, and the screws face inwards from the outside towards the inside of the box spring.

★ Tips: For the following steps, do not tighten the screws completely; just screw them in a few turns to ensure the frame doesn't fall apart. Tighten all the screws in the final step.

Step 1:

Connect components **HS** and **SS** using screw **B** as shown to form the frame.

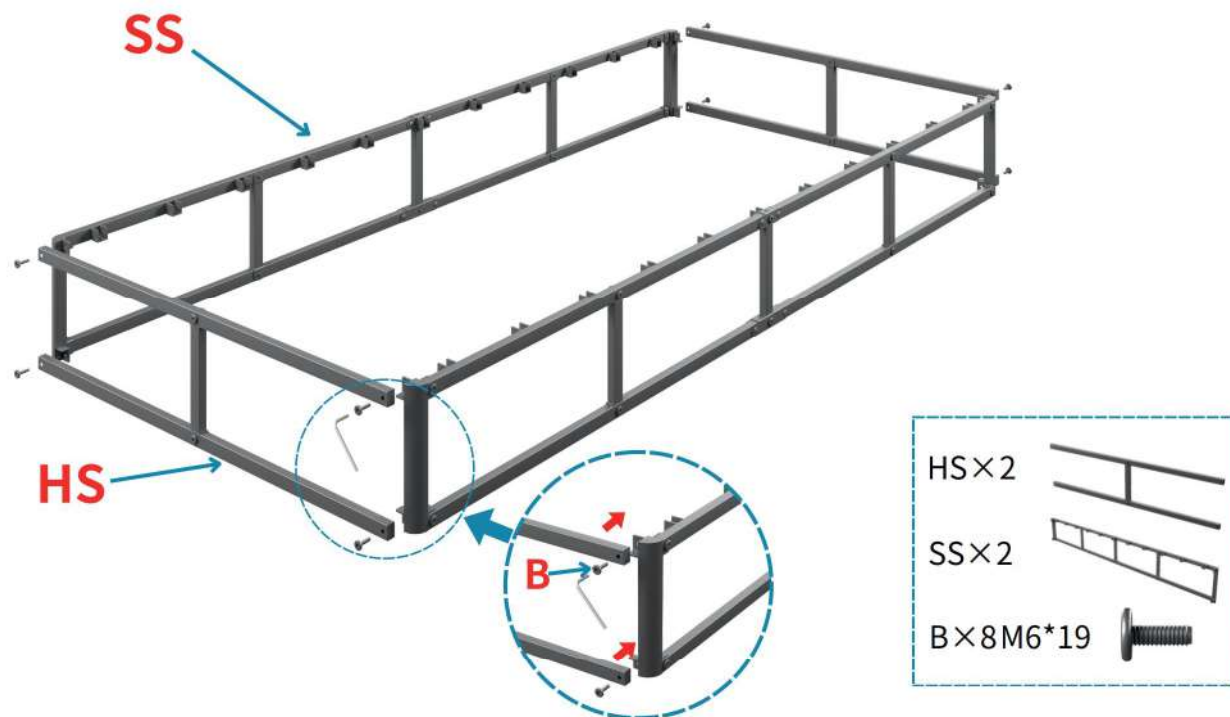

Step 2:

Joint part ④ to the frame with screws **A** as shown.

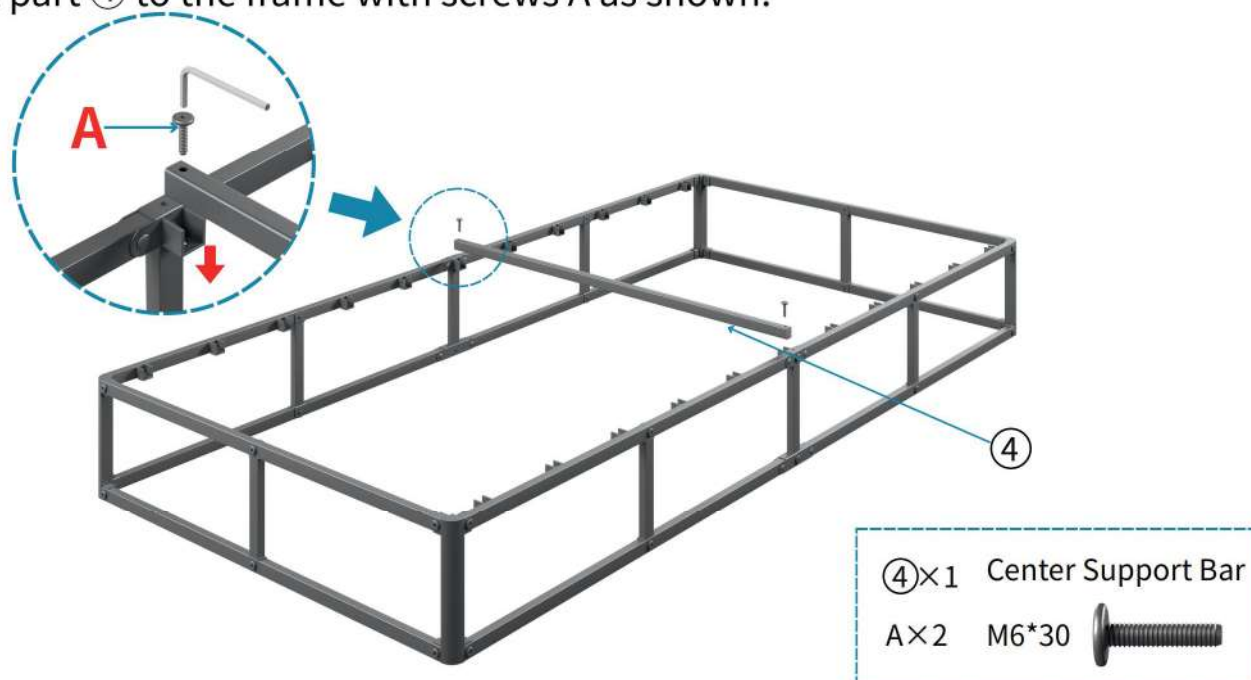

Step 3:

Place two special slats ⑩ as shown, one at the third slat from the front and the other at the third slat from the back.

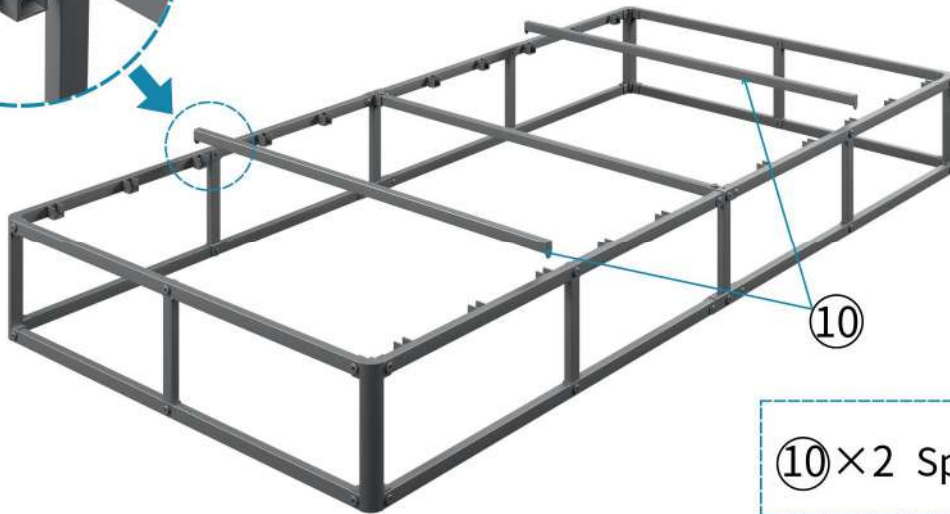

Step 4:

Insert normal slats, then **tighten all the screws.**

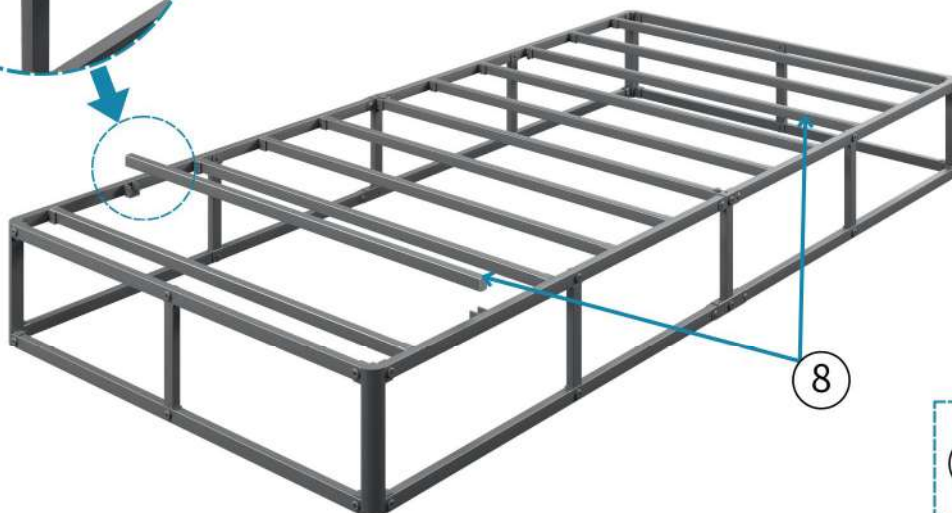

Step 5:

Put on the bed cover ⑨, then completed.

Tuck all four elastic straps under the corners.



⑨ × 1 Bed Cover

Note:

Check the tightness of all screws, retighten them, and ensure the structure is stable.

Reminder:

Regularly inspect the tightness of screws every 6 months. Retighten any loose ones promptly to maintain stability.

Cleaning & Care:

Use a dry or slightly damp soft cloth for cleaning. Avoid abrasive cleaners and corrosive substances (e.g., alcohol, bleach) to protect the product's finish. Regularly wipe off dust to extend service life.

Please keep this instructions for future reference!

[Back to Top](#)

[Back to Top](#)

ASSEMBLY INSTRUCTION

Box Spring

Size: Full/Queen/King/California King (03/04/05/06)

















★ You can contact us via the marketplace order message center for any product questions. We will reply within 24 hours. Thanks for your support!

★ In case of missing or damaging parts, please provide your order number and the name of the required part to apply for a replacement.

★ Power tools **are prohibited** for installation, as they may cause thread stripping.

★ **Do not full tighten any screws until the entire assembly is completed.** This allows for proper alignment and adjustments during the assembly process. Tightening them all at the end will result in a more stable structure.

			
①×1 Center Bracket	②×2 Bedhead Bracket	④×2 Center Support Bar	⑤×2 Side Bracket
			
⑥×10 Side Rail	⑦×4 Bed Post	⑧×16 Slat	⑨×1 Bed Cover
	<p>Legend: ① x1 means Part No.① , 1 piece. M6*30 means an M6 - sized screw with a length of 30mm.</p>		
⑩×4 Special Slat			

					Spare A×1 B×1
H×1 4mm	B×28 M6*19	A×4 M6*30	B×8 M6*19	A×4 M6*30	

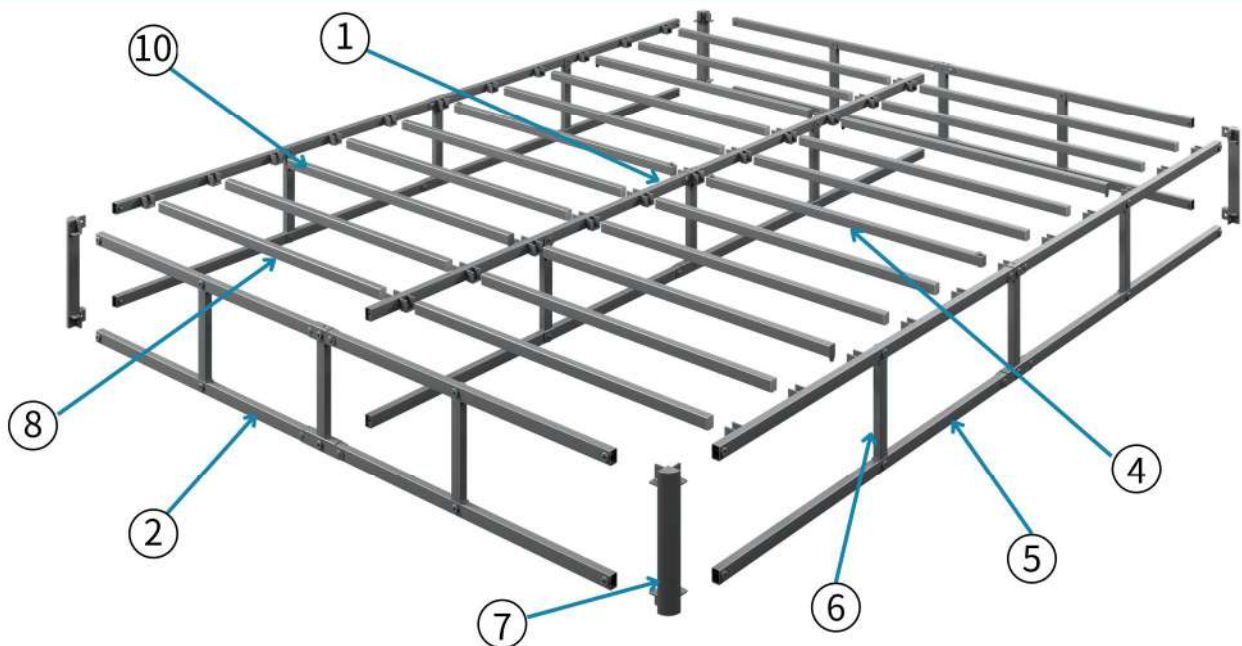

★ This product only includes the parts numbered above, and the missing numbers are not used in this product.

Pre-Assembly

1: Connect part ⑤ and ⑥ with screws B, **creating 2 assembled parts called "SS"**.

⑤×2 Side Bracket

⑥×4 Side Rail

B×8 M6*19 

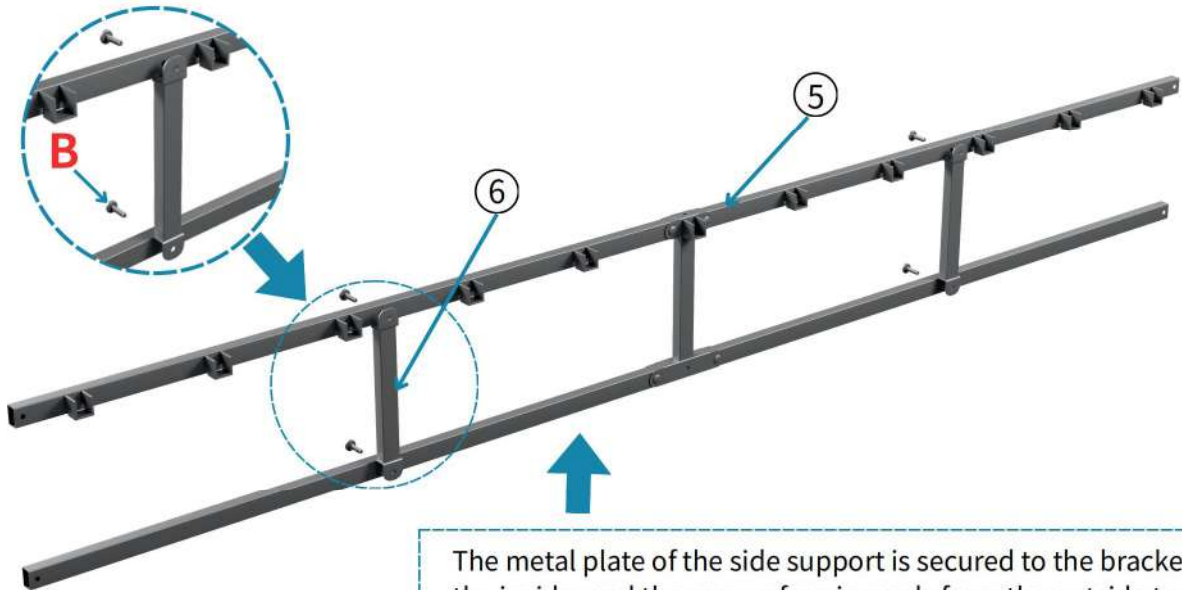

The metal plate of the side support is secured to the bracket from the inside, and the screws face inwards from the outside towards the inside of the box spring.

2: Connect part ② and ⑥ with screws B;
Then joint part ⑦ with screws B **creating 2 assembled parts called "HS"**.

Note: Positions ⑥ and ⑦ must be on the same side.

②×2 Bedhead Bracket

⑥×4 Side Rail

⑦×4 Bed Post

B×16 M6*19 

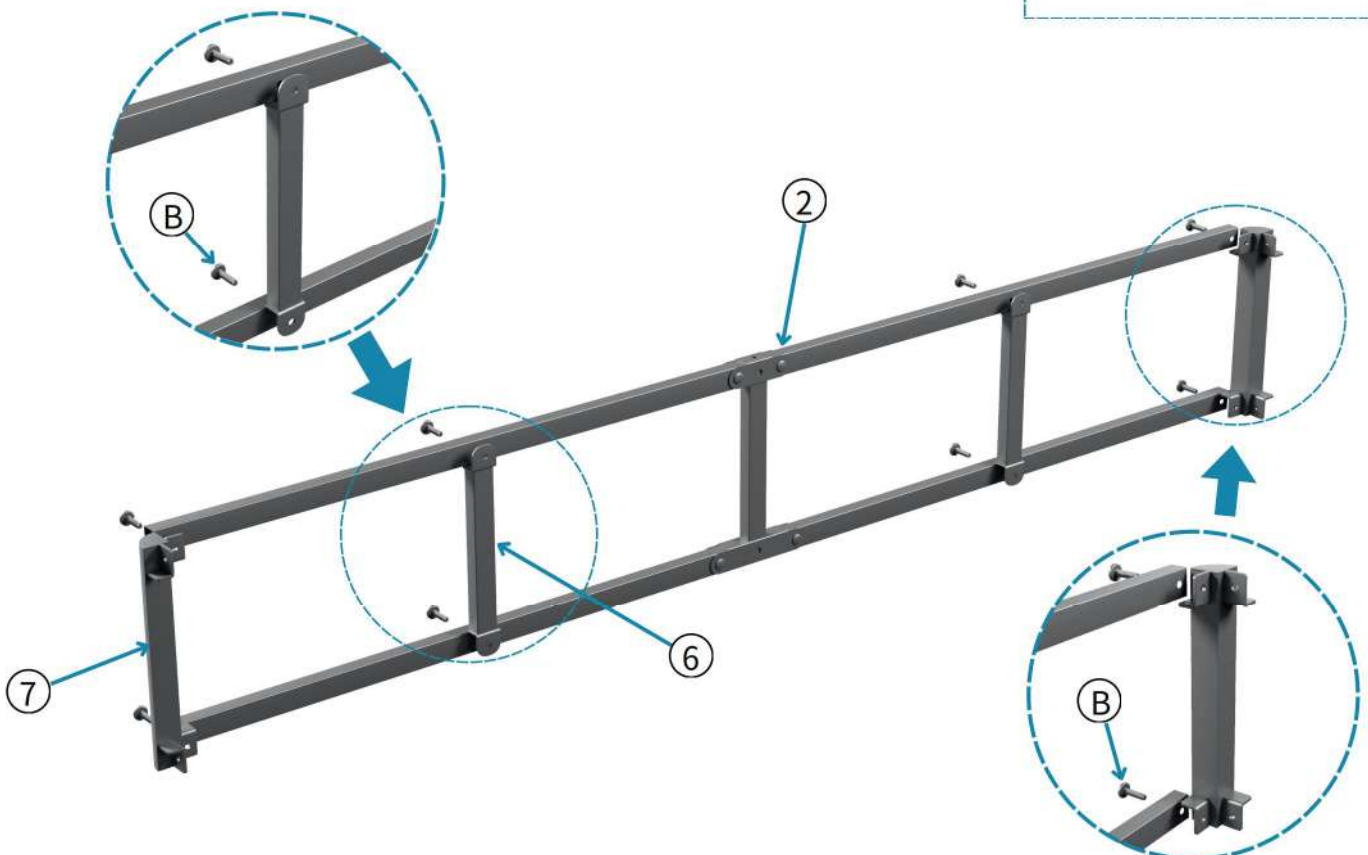

3: Connect part ① and ⑥ with screws B as shown, creating 2 assembled parts called "CS".

①×1 Center Bracket

⑥×2 Side Rail

B×4 M6*19 

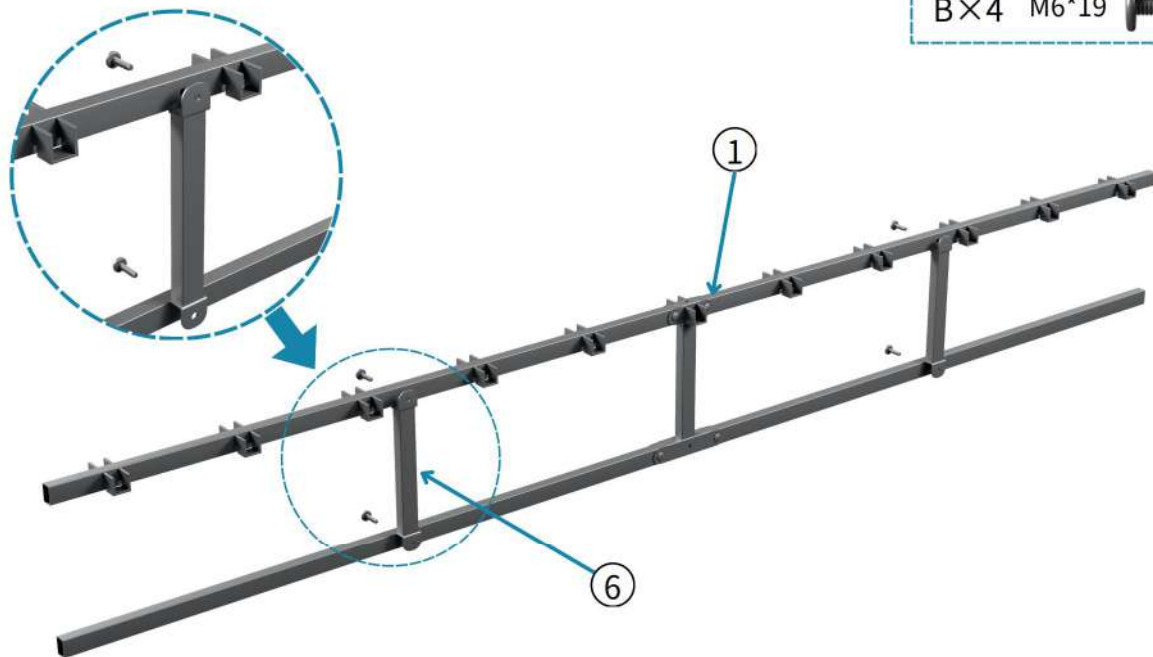

★Tips: For the following steps, do not tighten the screws completely; just screw them in a few turns to ensure the frame doesn't fall apart. Tighten all the screws in the final step.

Step 1:

Connect components CS and HS using screw A as shown to form the frame.

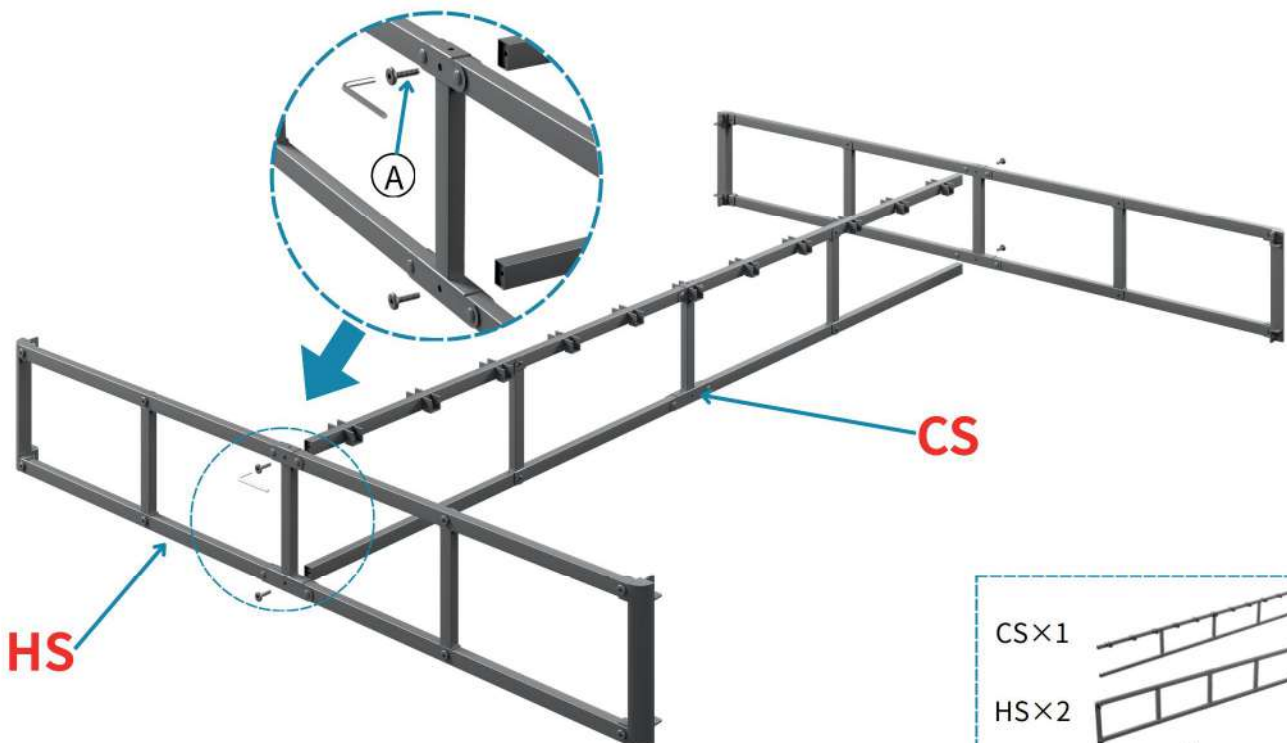

CS×1 

HS×2 

A×4 M6*30 

Step 2:

Joint part **SS** with screws B as shown.

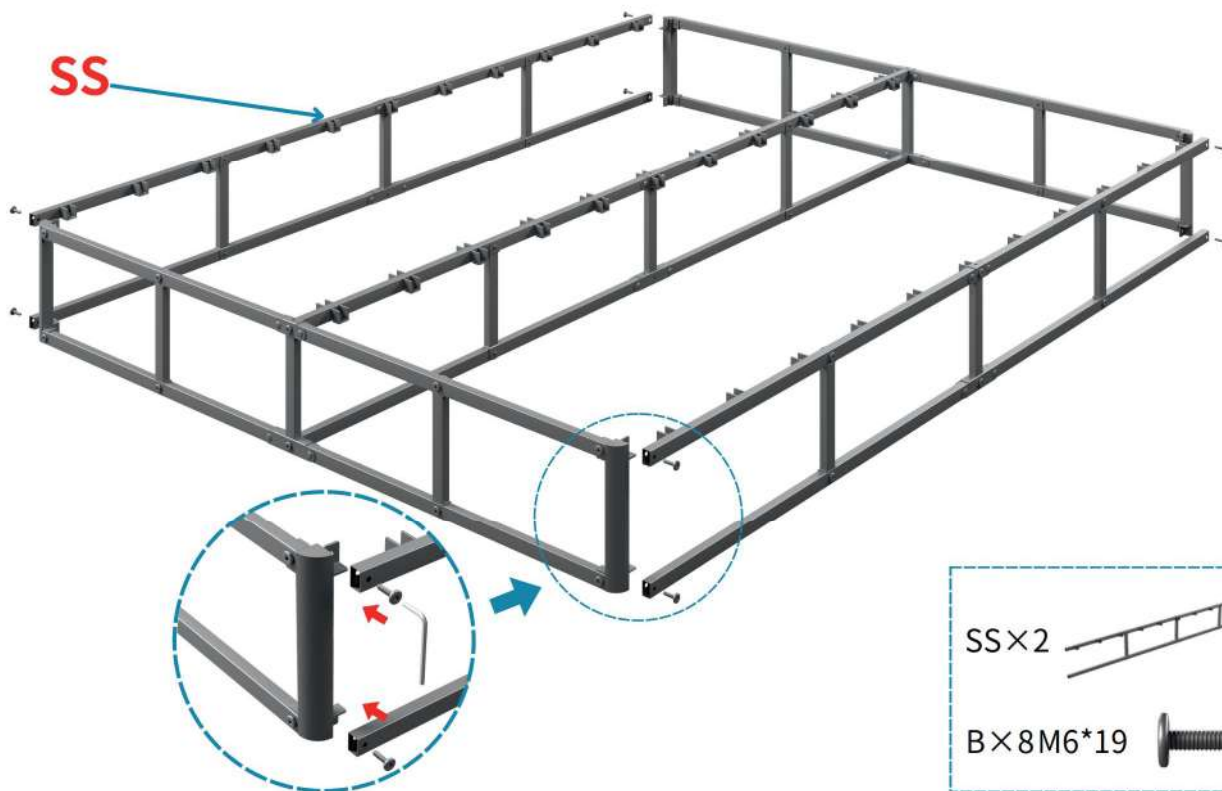

Step 3:

Joint part ④ to the frame with screws A as shown.

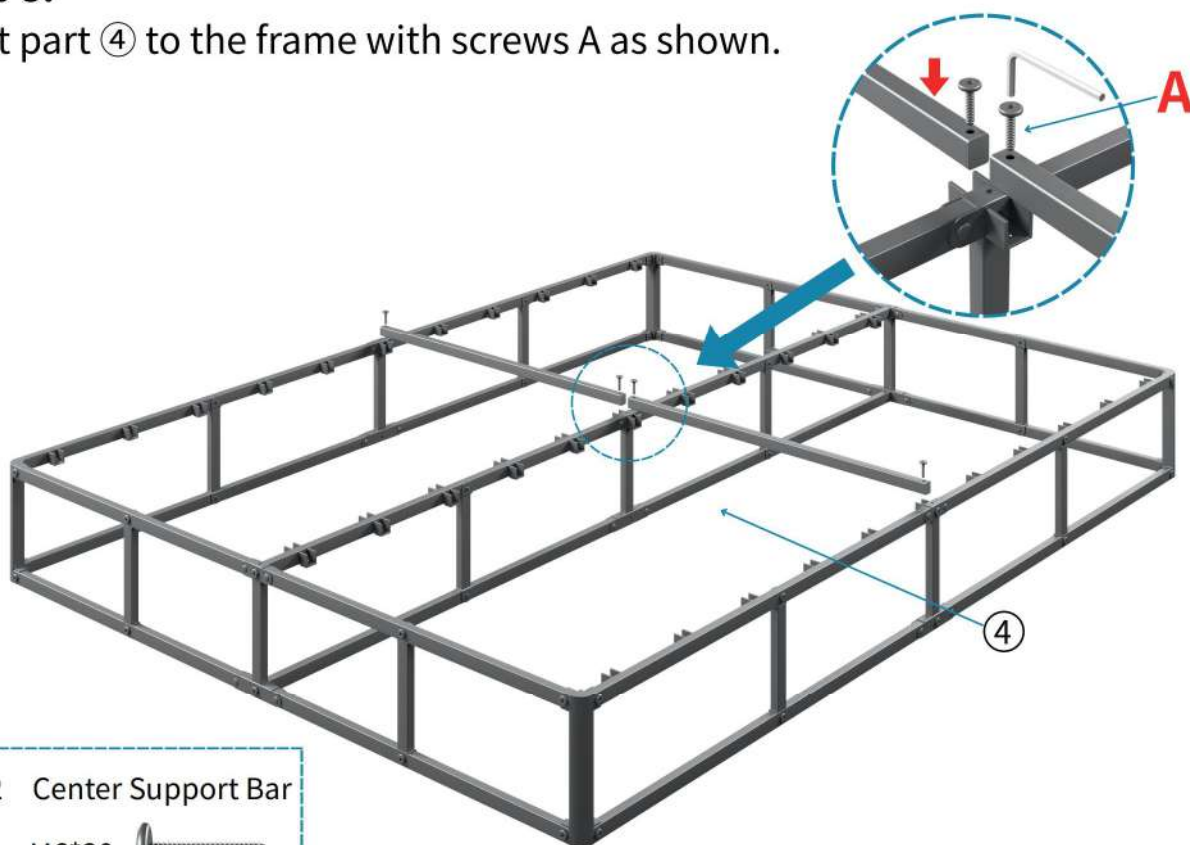

Step 4:

Place four special slats ⑩ as shown, two at the third slat from the front and the others at the third slat from the back.

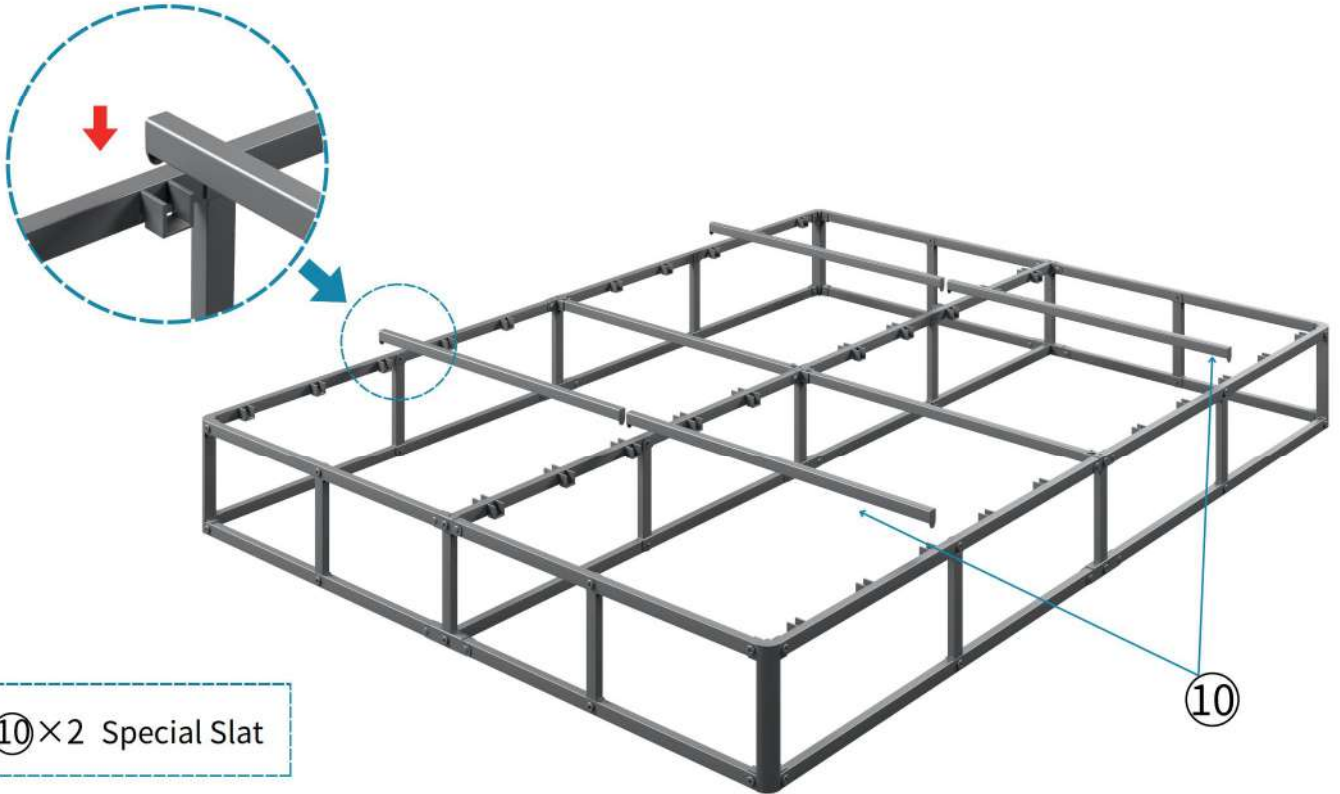

Step 5:

Insert normal slats, then **tighten all the screws.**

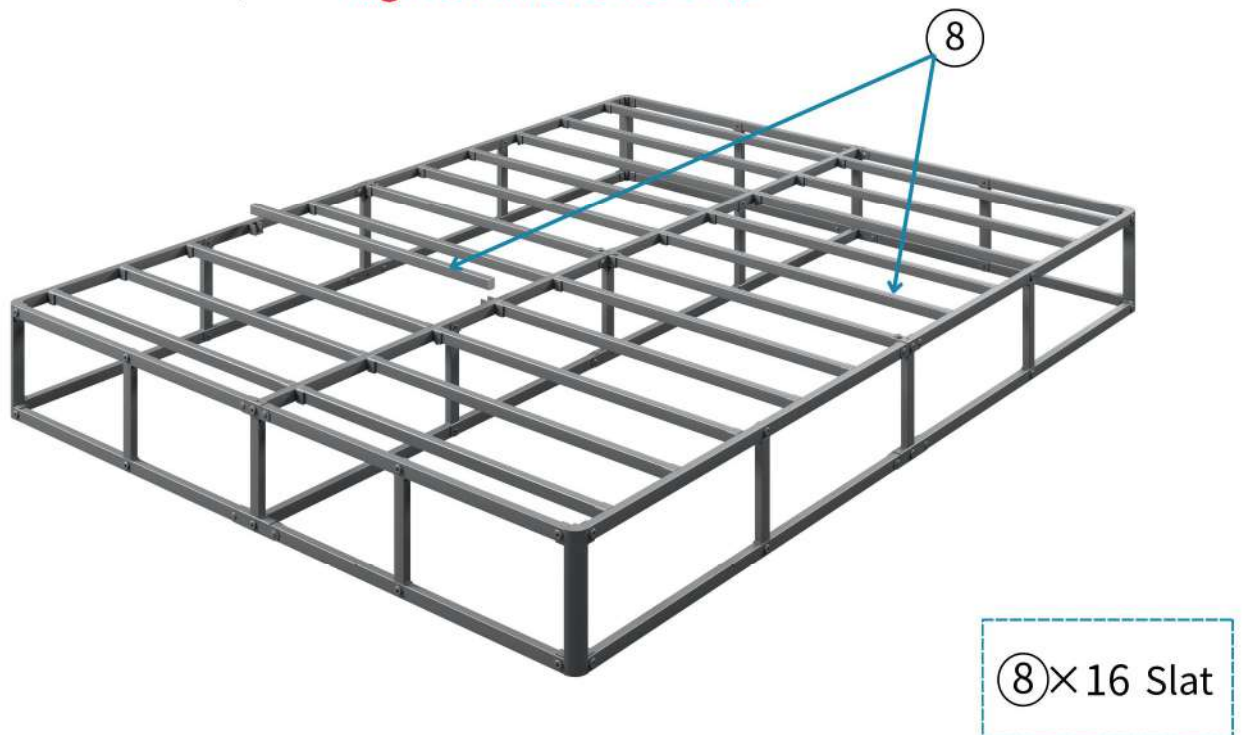

Step 6:

Put on the bed cover ⑨, then completed.

Tuck all four elastic straps under the corners.



⑨×1 Bed Cover

Note:

Check the tightness of all screws, retighten them, and ensure the structure is stable.

Reminder:

Regularly inspect the tightness of screws every 6 months.

Retighten any loose ones promptly to maintain stability.

Cleaning & Care:

Use a dry or slightly damp soft cloth for cleaning. Avoid abrasive cleaners and corrosive substances (e.g., alcohol, bleach) to protect the product's finish. Regularly wipe off dust to extend service life.

Please keep this instructions for future reference!

[Back to Top](#)