

Rattan Adjustable Cylinder Sofa

If you have any questions about the rattan adjustable cylinder sofa , please feel free to contact us.

EN

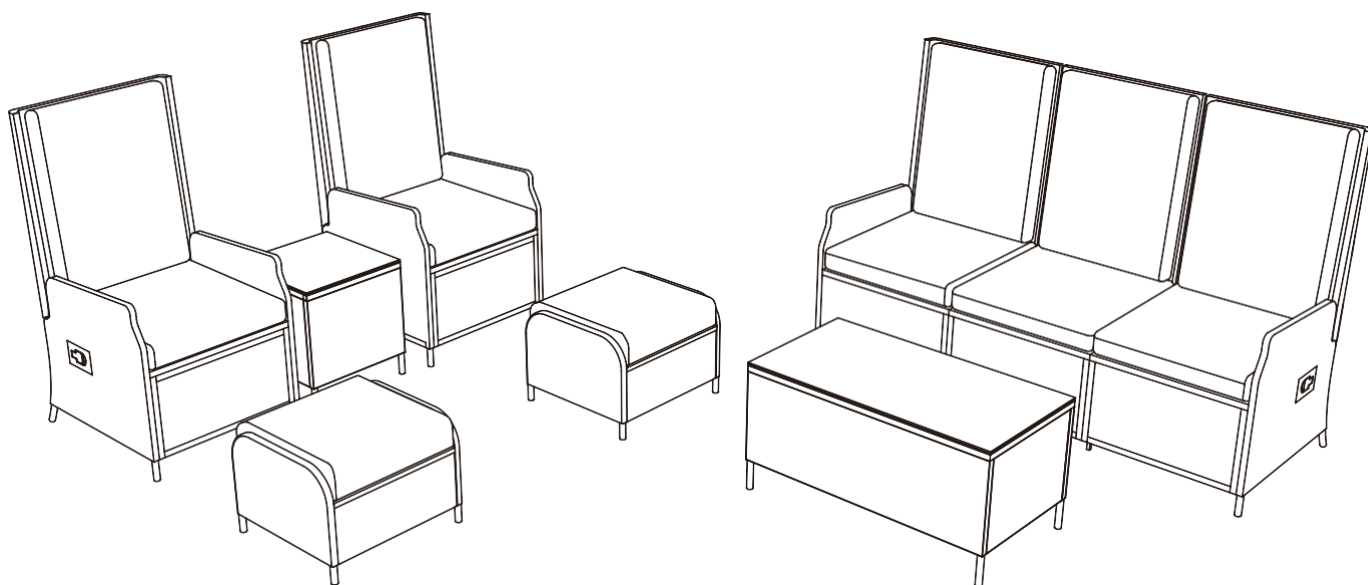

IMPORTANT

PLEASE READ BEFORE YOU COMMENCE ASSEMBLY

Follow the guidelines in this user guide to ensure correct
assembly and care for this product.

SPECIFICATIONS

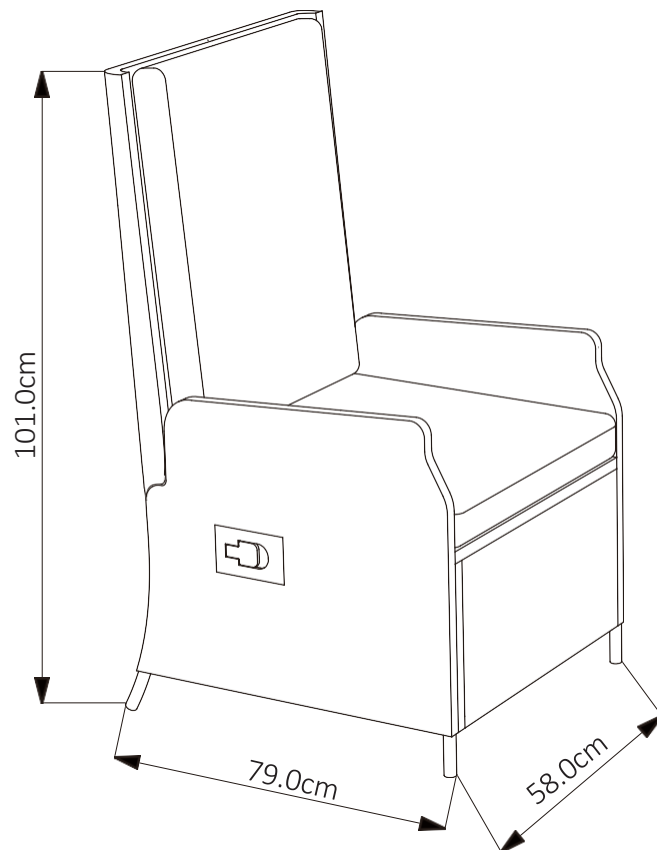
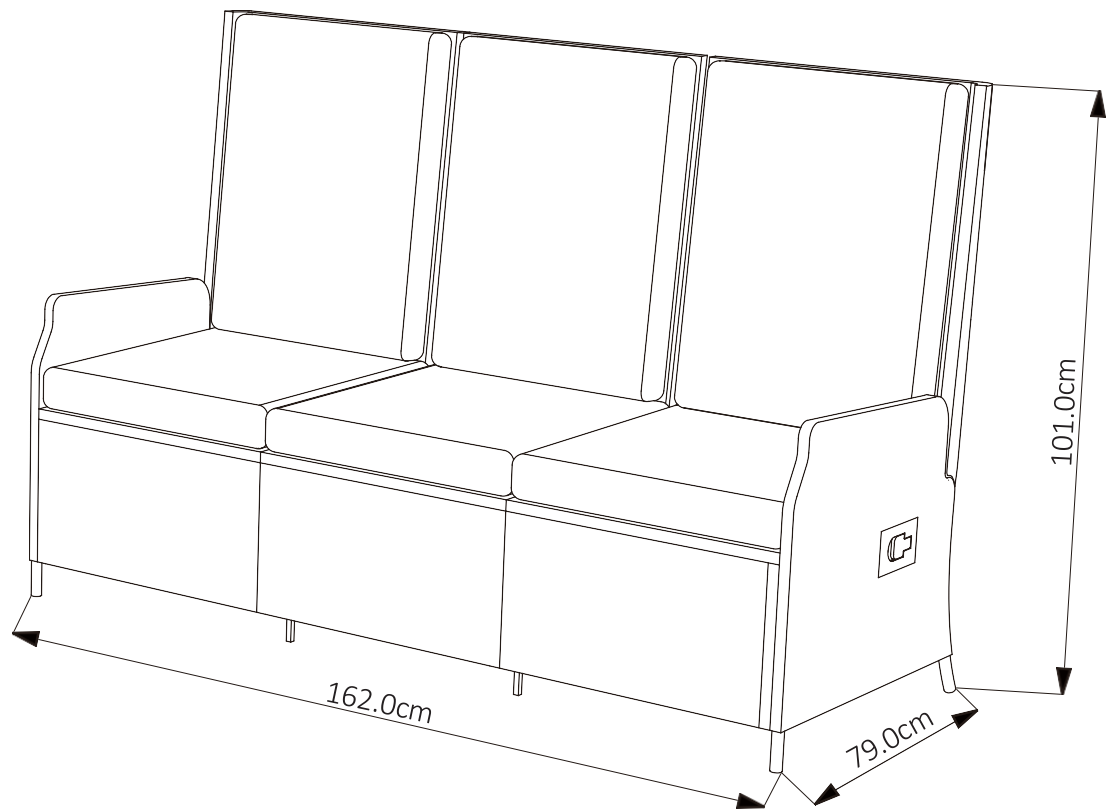

SPECIFICATIONS

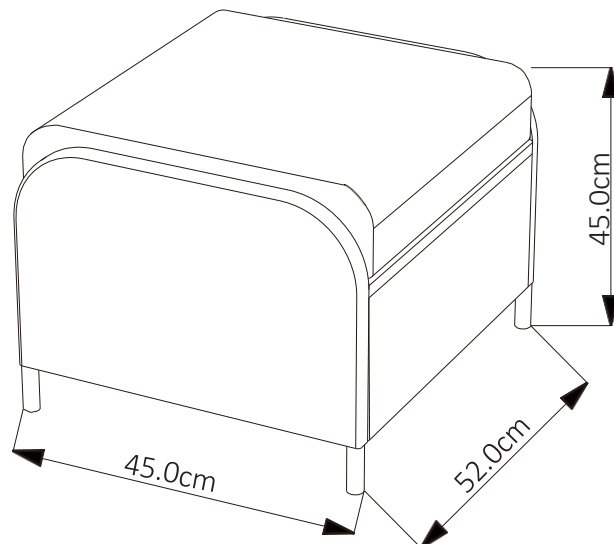
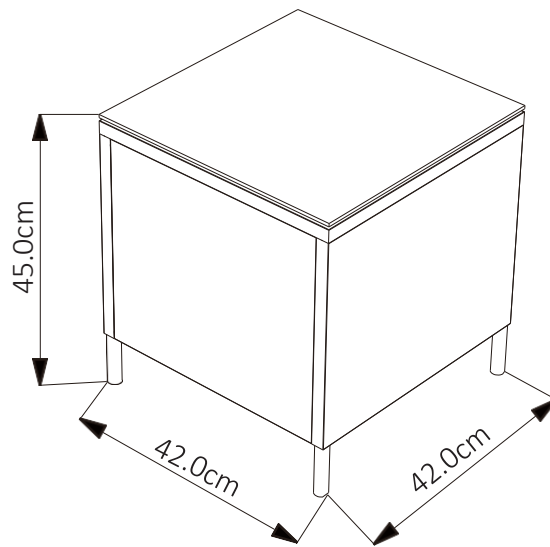
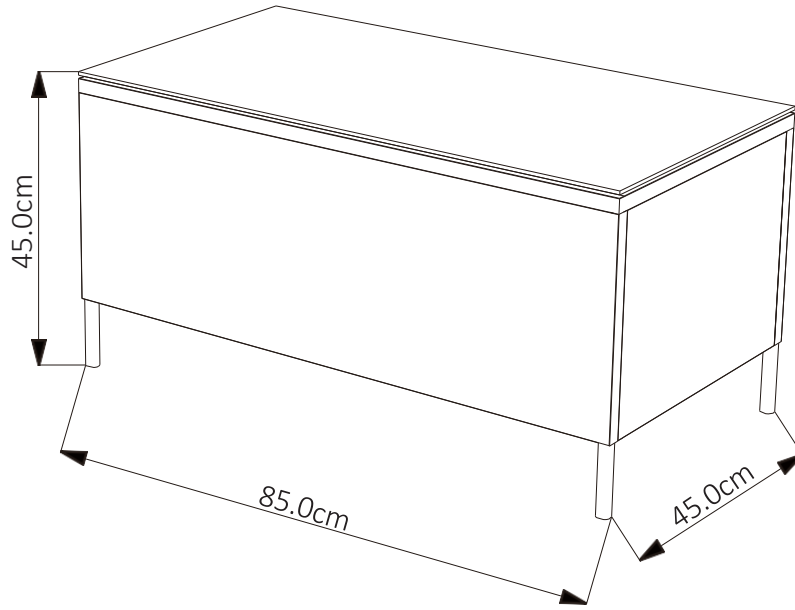

Catalog

Specifications.....	01
Before you begin	03
Part List And Extra	04
How to Assemble The Single Sofa	10
How to Assemble The Three-person Sofa.....	14
How to Assemble The Footrests	22
How to Assemble The Square Coffee Table.....	24
How to Assemble The Long Coffee Table.....	26

NOTICE

Before You Begin

Assembly Instructions:

Instructions are supplied in this manual and contain all appropriate information for your building model.

Review all instructions before you begin and during assembly · follow the step sequence carefully for correct results.

Parts and Parts List:

Check to be sure that you have all the necessary parts for building.

Separate contents of the carton by the part number while reviewing parts list.











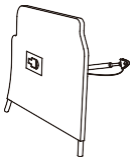
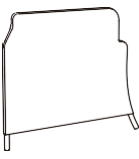
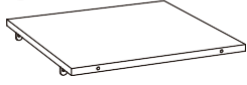
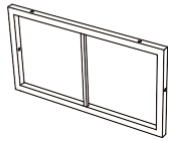

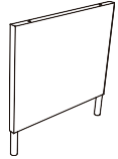
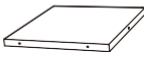
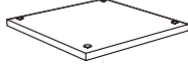
Familiarize yourself with the hardware and fasteners for easier use during construction.

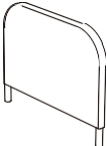
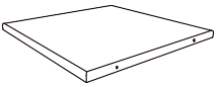
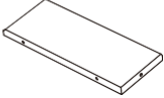
The first few steps show how to join related parts which is to obtain larger sub-assemblies be used later.

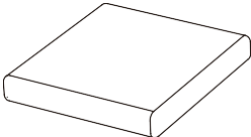
All parts are packaged within the carton.



Note that extra fasteners have been supplied for your convenience.

PART LIST





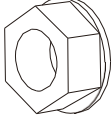
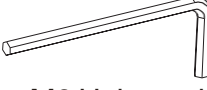
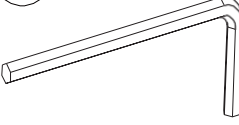
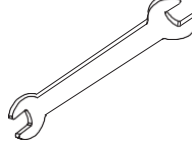

Parts List (Box A)				
 <p>A1 Single-seat Backplate</p>	 <p>B1 Right Armrest With Air Bar</p>	 <p>B2 Left Armrest</p>	 <p>C1 Base Plate</p>	 <p>D1 Front Panel</p>
1 PC	1 PC	1 PC	1 PC	1 PC
 <p>E Supporting Crossbar</p>	 <p>F1 Square Coffee Table Legs</p>	 <p>G1 Square Coffee Table Side Panel</p>	 <p>H1 Square Coffee Table Tabletop</p>	 <p>I1 Square Coffee Table Glass</p>
1 PC	2 PCS	2 PCS	1 PC	1 PC
 <p>J Footrest Legs</p>	 <p>K Footrest Base Board</p>	 <p>L Footrest Side Panel</p>	 <p>O Back Cushion</p>	 <p>P1 Cushion</p>
2 PCS	1 PC	2 PCS	1 PC	1 PC
 <p>P2 Footrest Cushion</p>				
1 PC				
Screws Set A				
 <p>Q1 M6*15</p>	 <p>Q2 M6*20</p>	 <p>Q4 M6*35</p>	 <p>Q6 M8*40</p>	 <p>S1 M6 Nut</p>
4 PCS	2 PCS	32 PCS	2 PCS	2 PCS

PART LIST

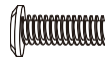
Screws Set A



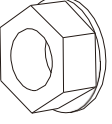



<p>(S2)</p>  <p>M8 Nut</p>	<p>(T1)</p>  <p>M6 Universal Wrench</p>	<p>(T2)</p>  <p>M8 Universal Wrench</p>	<p>(U1)</p>  <p>Wrench</p>	<p>(R)</p>  <p>Plastic Gasket</p>
2 PCS	1 PC	1 PC	1 PC	2 PCS

Extra (Box A)

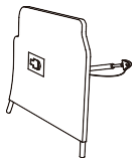
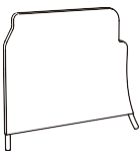

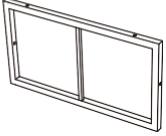

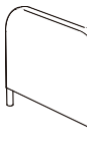
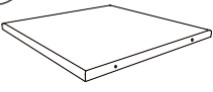
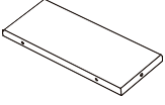

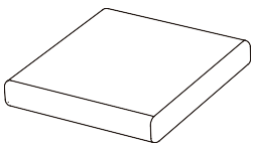
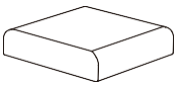

<p>(Q1)</p>  <p>M6*15</p>	<p>(Q2)</p>  <p>M6*20</p>	<p>(Q4)</p>  <p>M6*35</p>	<p>(Q6)</p>  <p>M8*40</p>	<p>(S1)</p>  <p>M6 Nut</p>
2 PCS	1 PC	2 PCS	1 PC	1 PC
<p>(S2)</p>  <p>M8 Nut</p>	<p>(R)</p>  <p>Plastic Gasket</p>			
1 PC	1 PC			

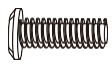
PART LIST



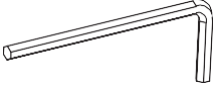

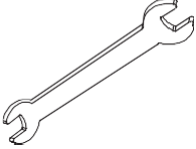

Parts List (Box B)

<p>(A1)</p>  <p>Single-seat Backplate</p>	<p>(B1)</p>  <p>Right Armrest With Air Bar</p>	<p>(B2)</p>  <p>Left Armrest</p>	<p>(C1)</p>  <p>Base Plate</p>	<p>(D1)</p>  <p>Front Panel</p>
1 PC	1 PC	1 PC	1 PC	1 PC
<p>(E)</p>  <p>Supporting Crossbar</p>	<p>(J)</p>  <p>Footrest Legs</p>	<p>(K)</p>  <p>Footrest Base Board</p>	<p>(L)</p>  <p>Footrest Side Panel</p>	<p>(O)</p>  <p>Back Cushion</p>
1 PC	2 PCS	1 PC	2 PCS	1 PC
<p>(P1)</p>  <p>Cushion</p>	<p>(P2)</p>  <p>Footrest Cushion</p>			
1 PC	1 PC			

Screws Set B



<p>(Q1)</p>  <p>M6*15</p>	<p>(Q2)</p>  <p>M6*20</p>	<p>(Q4)</p>  <p>M6*35</p>	<p>(Q6)</p>  <p>M8*40</p>	<p>(S1)</p>  <p>M6 Nut</p>
4 PCS	2 PCS	20 PCS	2 PCS	2 PCS
<p>(S2)</p>  <p>M8 Nut</p>	<p>(T1)</p>  <p>M6 Universal Wrench</p>	<p>(T2)</p>  <p>M8 Universal Wrench</p>	<p>(U1)</p>  <p>Wrench</p>	<p>(R)</p>  <p>Plastic Gasket</p>
2 PCS	1 PC	1 PC	1 PC	2 PCS

PART LIST





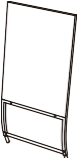
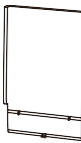

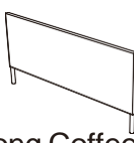
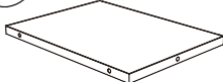
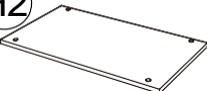



Extra (Box B)				
<p>Q1</p>  <p>M6*15</p>	<p>Q2</p>  <p>M6*20</p>	<p>Q4</p>  <p>M6*35</p>	<p>Q6</p>  <p>M8*40</p>	<p>S1</p>  <p>M6 Nut</p>
2 PCS	1 PC	2 PCS	1 PC	1 PC
<p>S2</p>  <p>M8 Nut</p>	<p>R</p>  <p>Plastic Gasket</p>			
1 PC	1 PC			

PART LIST





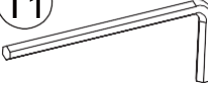
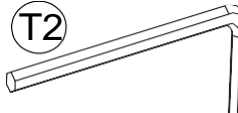
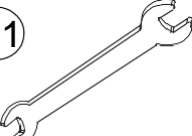



Parts List (Box C)

 <p>A2 Middle back panel 1 PC</p>	 <p>A3 Right Back Panel 1 PC</p>	 <p>A4 Left Back Panel 1PC</p>	 <p>F2 Long Coffee Table Legs 2 PCS</p>	 <p>G2 Side Panel Of Long Coffee Table 2 PCS</p>
 <p>H2 Long Coffee Table Tabletop 1 PC</p>				

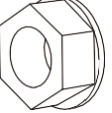

Screws Set C

 <p>Q1 M6*15 8 PCS</p>	 <p>Q2 M6*20 4 PCS</p>	 <p>Q3 M6*30 10 PCS</p>	 <p>Q4 M6*35 26 PCS</p>	 <p>Q5 M6*60 6 PCS</p>
 <p>Q6 M8*40 4 PCS</p>	 <p>S1 M6 Nut 10 PCS</p>	 <p>S2 M8 Nut 4 PCS</p>	 <p>T1 M6 Universal Wrench 1 PC</p>	 <p>T2 M8 Universal Wrench 1 PC</p>
 <p>U1 Wrench 1 PC</p>	 <p>R Plastic Gasket 4 PCS</p>			

Extra (Box C)

 <p>Q1 M6*15 2 PCS</p>	 <p>Q2 M6*20 2 PCS</p>	 <p>Q3 M6*30 2 PCS</p>	 <p>Q4 M6*35 2 PCS</p>	 <p>Q5 M6*60 1 PC</p>
 <p>Q5 M8*40 1 PC</p>	 <p>S1 M6 Nut 1 PC</p>	 <p>S2 M8 Nut 1 PC</p>	 <p>R Plastic Gasket 1 PC</p>	

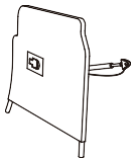
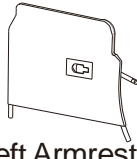
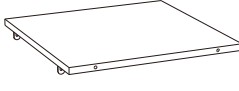
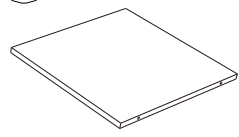
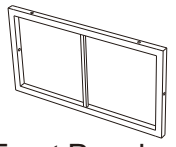
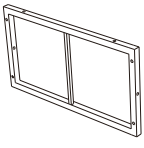
PART LIST

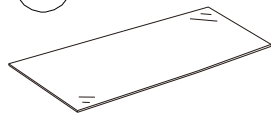
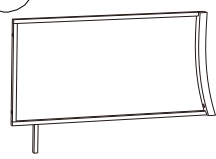
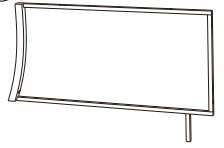
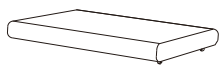
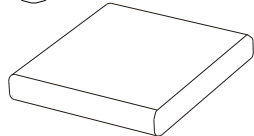
Parts List (Box D)				
 <p>B1 Right Armrest With Air Bar</p>	 <p>B3 Left Armrest With Air Bar</p>	 <p>C1 Base Plate</p>	 <p>C2 Middle Base Plate</p>	 <p>D1 Front Panel</p>
1 PC	1 PC	2 PCS	1 PC	2 PCS
 <p>D2 Middle Front Panel</p>	 <p>E Supporting Crossbar</p>	 <p>I2 Long Coffee Table Glass</p>	 <p>M Right Support Leg</p>	 <p>N Left Support Leg</p>
1 PC	2 PCS	1 PC	1 PC	1 PC
 <p>O Back Cushion</p>	 <p>P1 Cushion</p>			
3 PCS	3 PCS			





Installation steps

How To Assemble Single Sofa

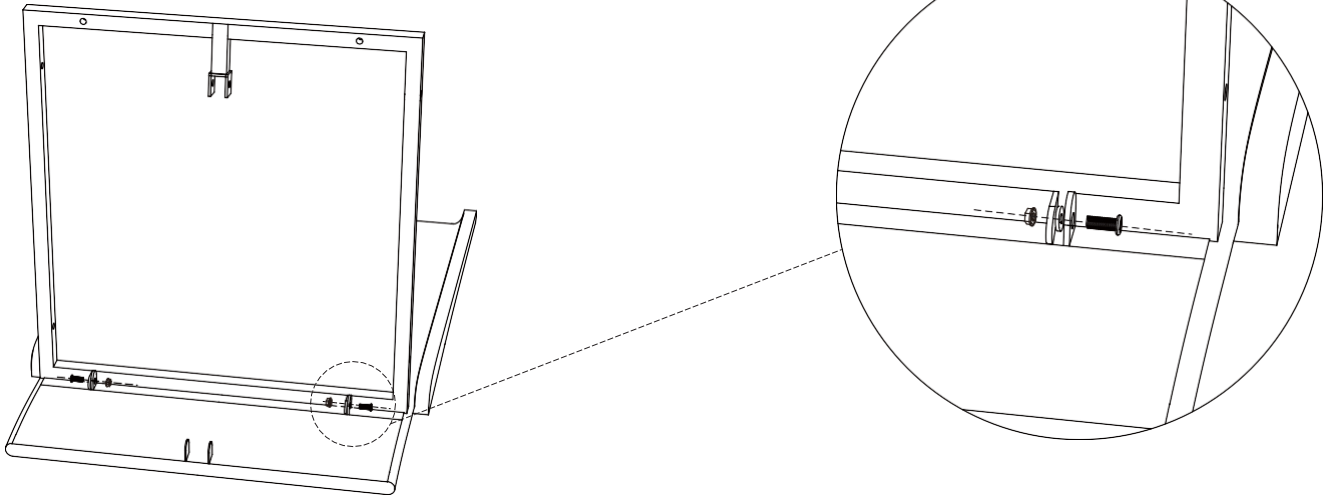
Step 1: Attach the base plate(C1) to the single seat back panel(A1).

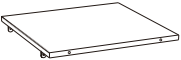
NOTE: Do not tighten the screws all the way.



A1		x1	C1		x1	Q2		M6x20	x2
						S1			x2
						R			x2

Step 2: Attach the front plate(D1) to the base plate.

NOTE: Do not tighten the screws all the way.

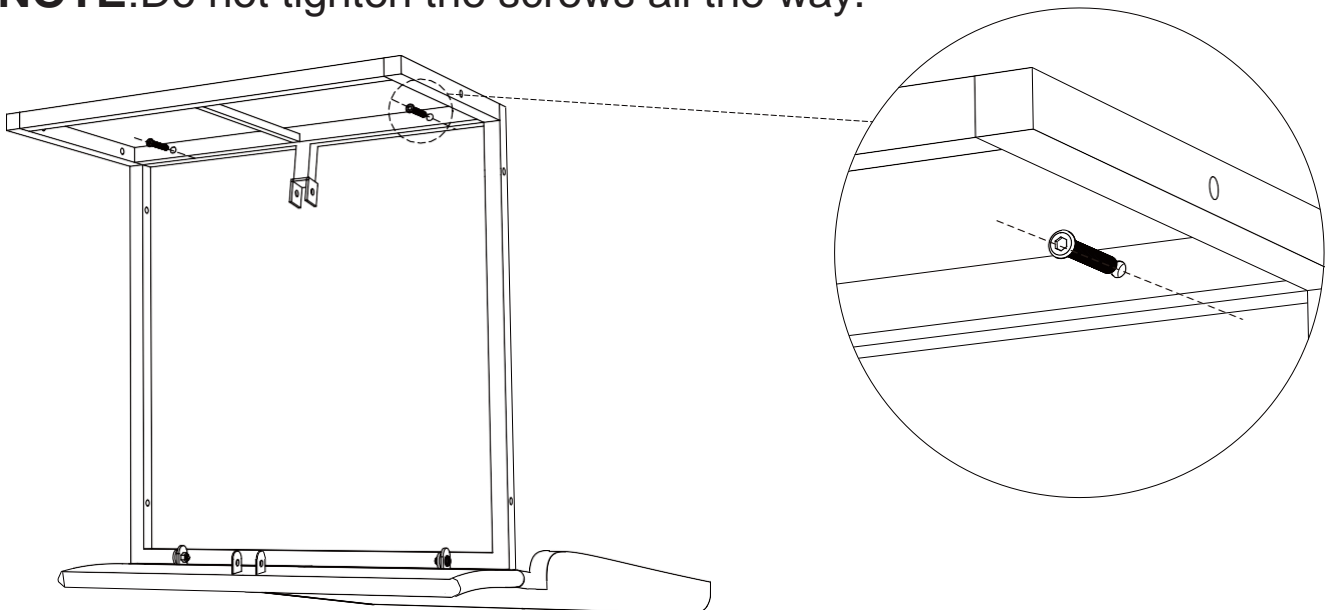

D1		x1	Q4		M6x35	x2
----	---	----	----	---	-------	----

Installation steps

Step 3: Install the left armrest(B2) on the base plate.

NOTE: Do not tighten the screws all the way.

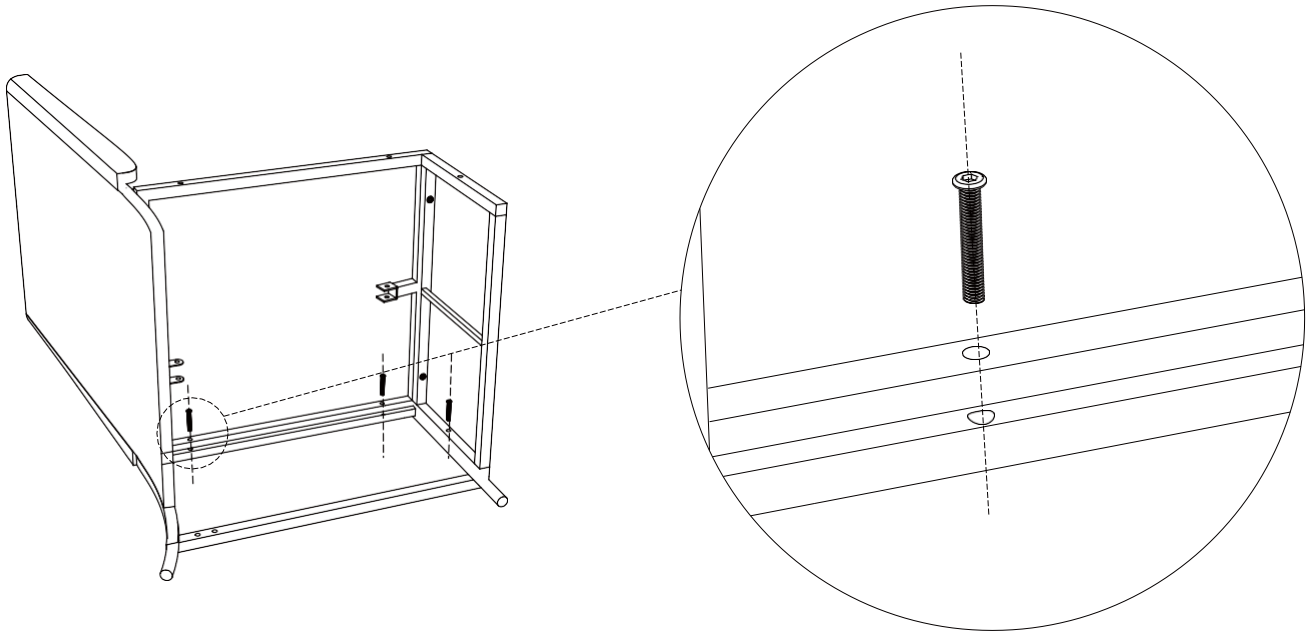

B2

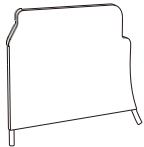

x1 Q4  M6x35 x3

Step 4: Install the right armrest(B1) on the base plate and attach the cylinder.

NOTE: Do not tighten the screws all the way.

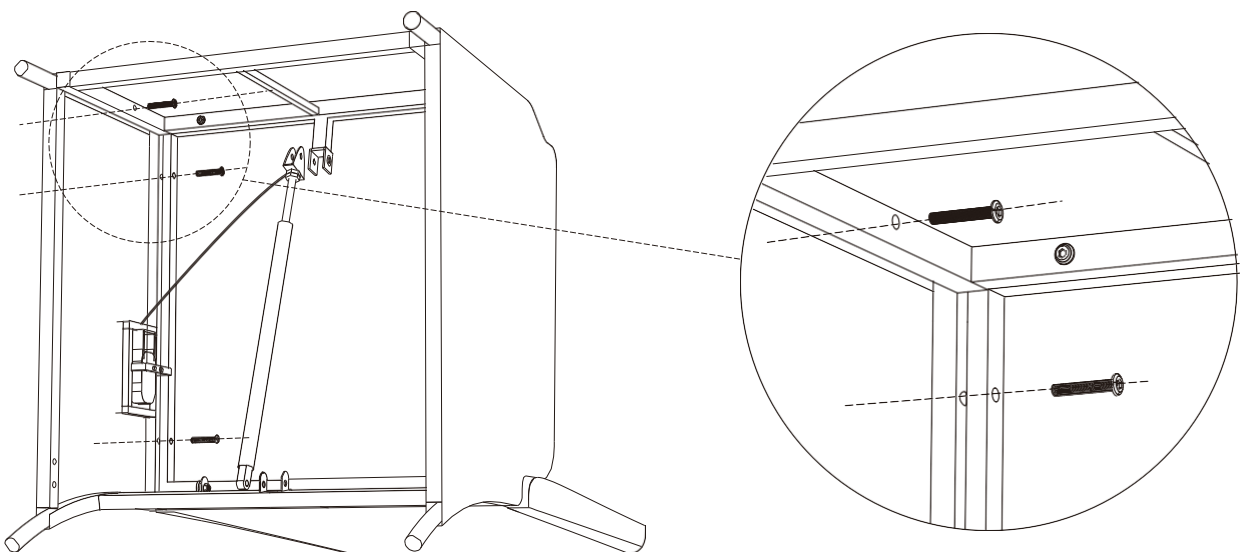

B1

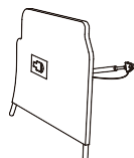



x1 Q4  M6x35 x3

Installation steps

Step 5: Connect the cylinder to the seat with the cylinder line on the side away from the seat.

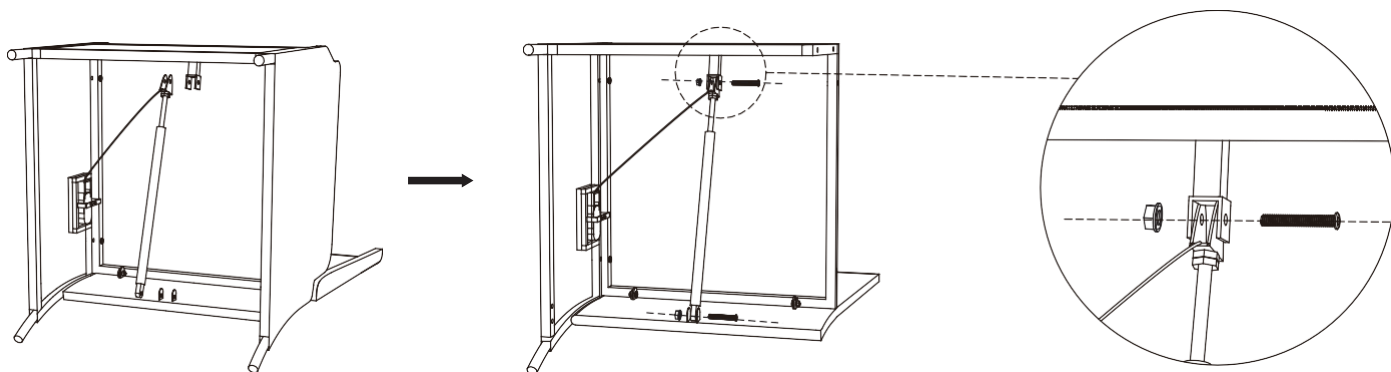
NOTE: Do not tighten the screws all the way.



Q6	 M8x40	x2	S2		x2
----	---	----	----	---	----

Step 6: Attach the support crossbar(E).

NOTE: Please tighten all screws.

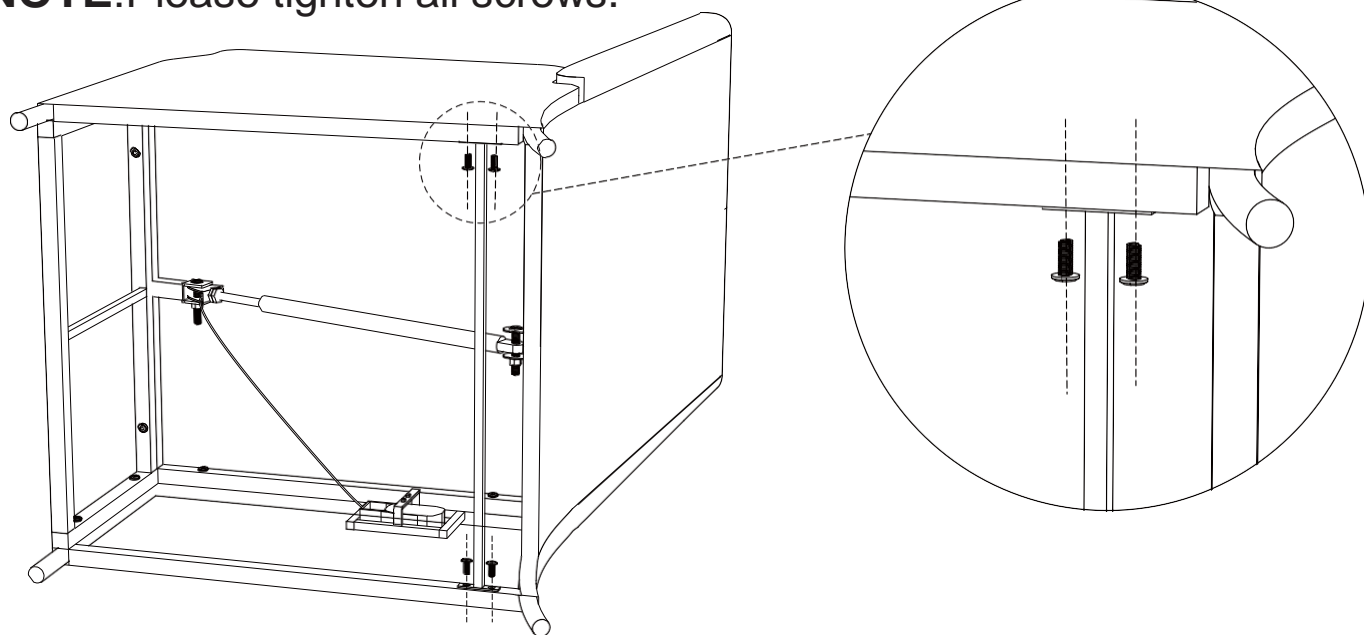

E		x1	Q1	 M6x15	x4
---	---	----	----	---	----

Installation steps

Step 7: Place the cushion (P1) on the sofa. Attach the back cushions (O) to the sofa and tuck the olive buckle into the rattan.

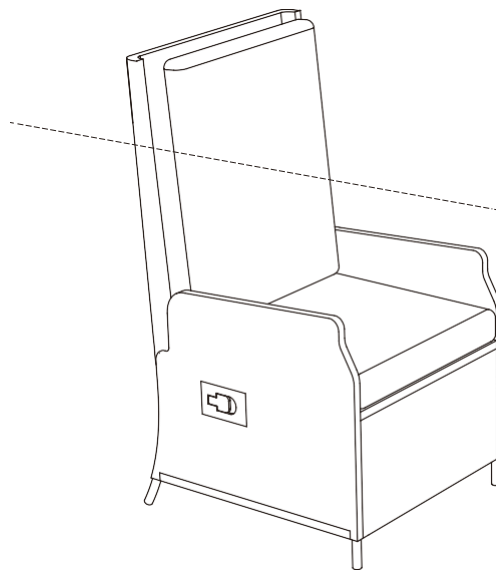
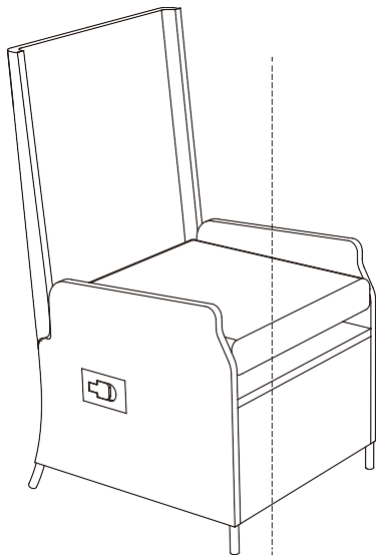

P1

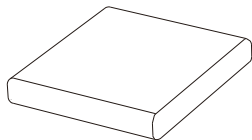

x1 O



x1

NOTE: In order for the cylinder to function properly, the screws of the cylinder need to be locked.

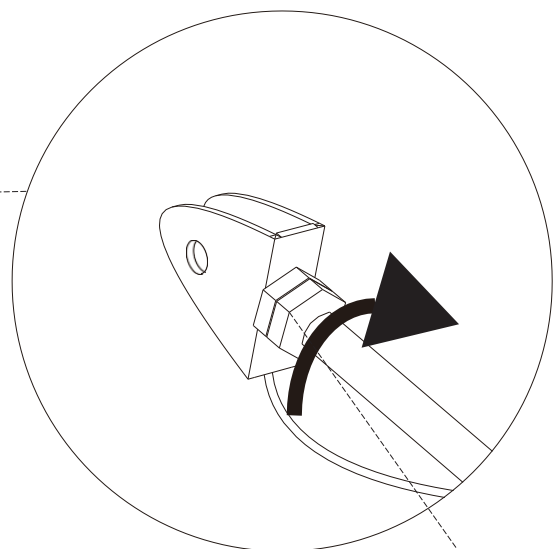
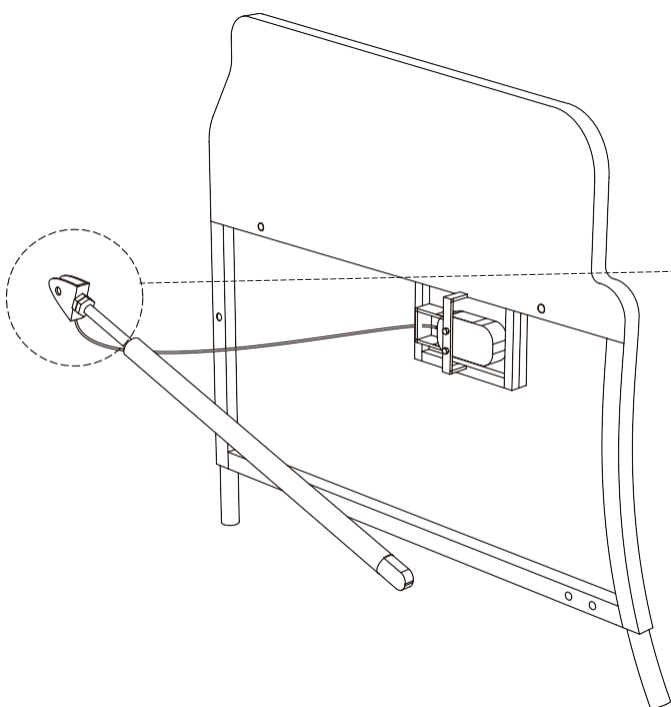

Tighten these two screws





Installation steps

How To Assemble Three-seat Sofa

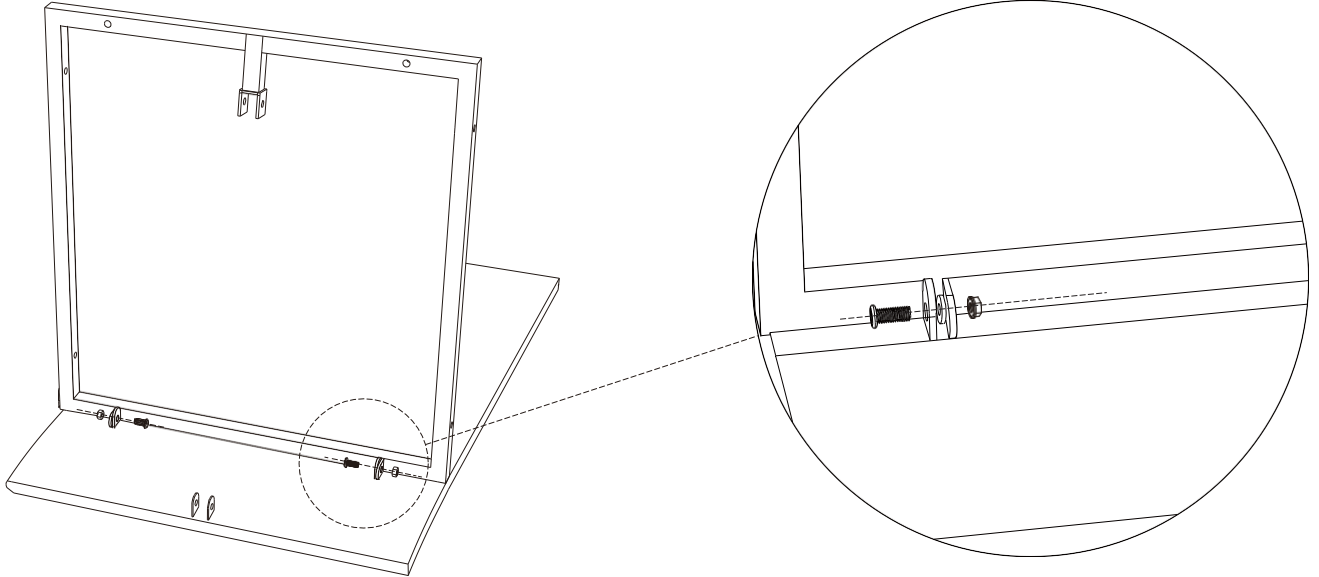
Step 1: Attach the base plate(C1) to the right back panel(A3).

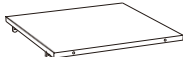
NOTE: Do not tighten the screws all the way.





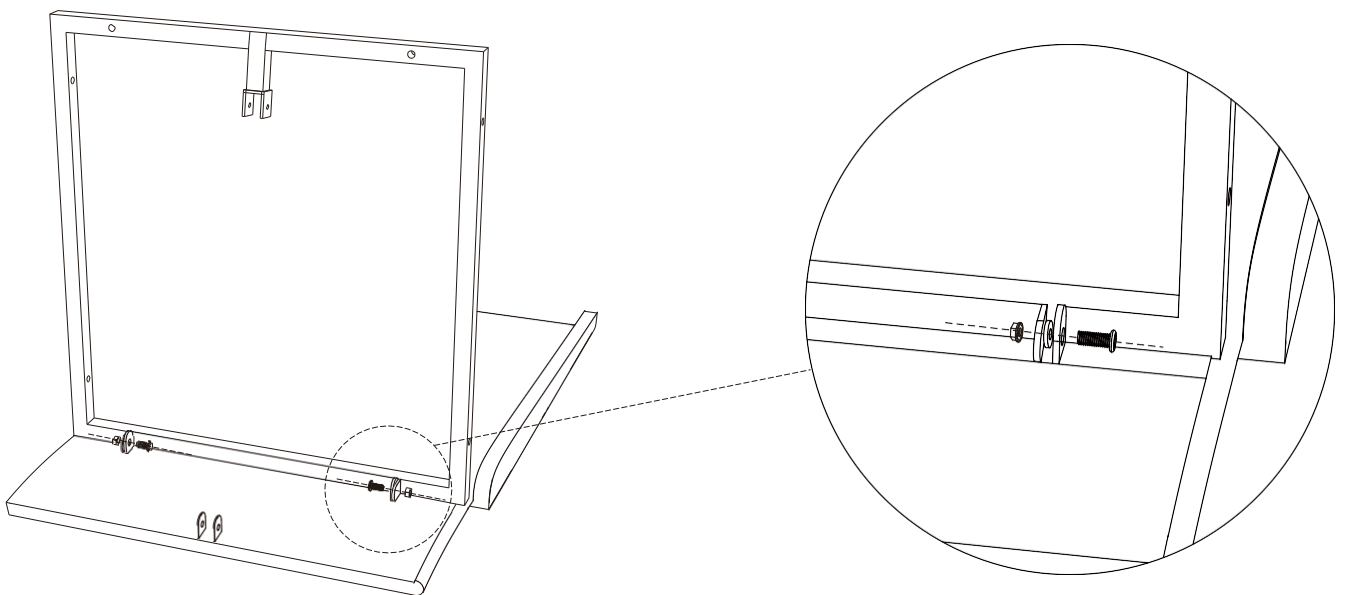

A3		x1	C1		x1	Q2		M6x20	x2
						S1			x2
						R			x2

Step 2: Attach the base plate(C1) to the left back panel(A4).

NOTE: Do not tighten the screws all the way.



A4		x1	C1		x1	Q2		M6x20	x2
						S1			x2
						R			x2

Installation steps

Step 3: Attach the middle base plate(C2) to the middle back panel(A2).
NOTE: Do not tighten the screws all the way.

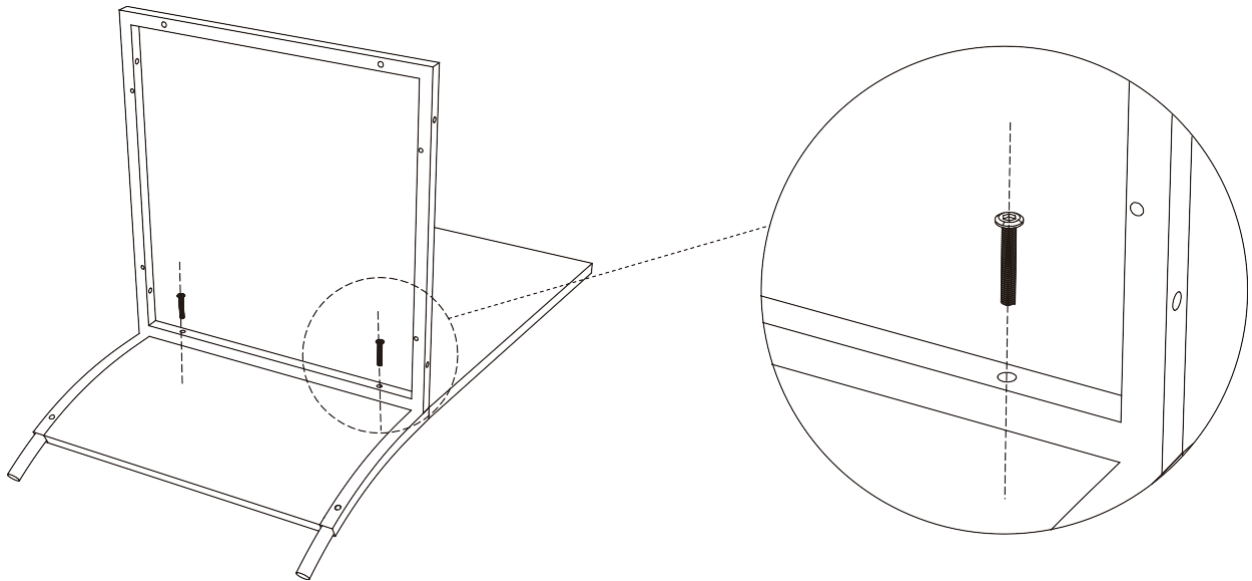

A2

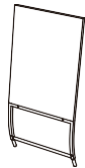

x1 C2

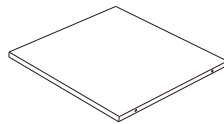

x1 Q4  M6x35 x2

Step 4: Attach the front plate(D1) to the right sofa.
NOTE: Do not tighten the screws all the way.

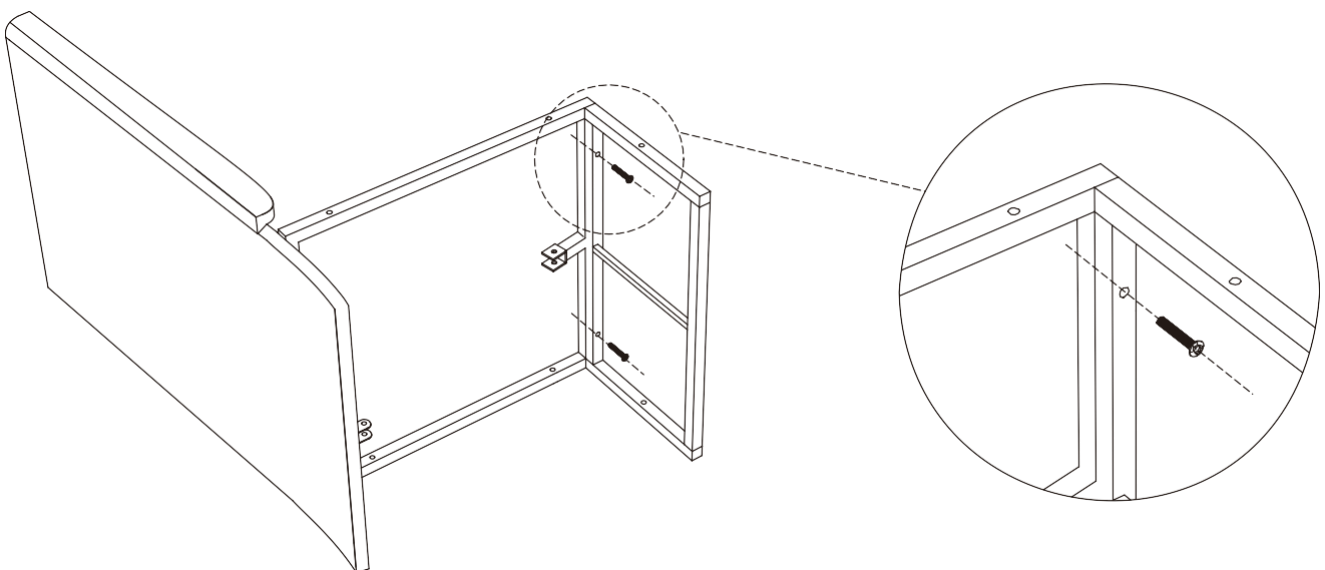

D1

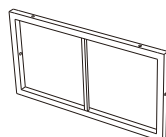

x1 Q4  M6x35 x2

Installation steps

Step 5: Attach the middle front plate(D2)to the middle sofa.

NOTE:Do not tighten the screws all the way.

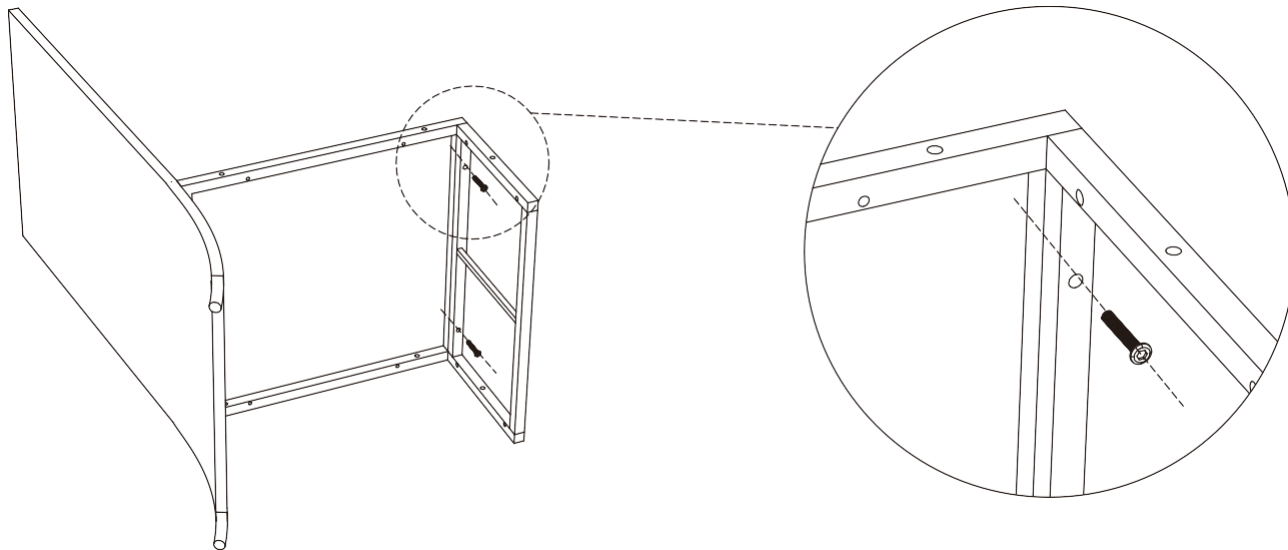

D2

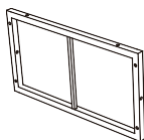

x1 Q4  M6x35 X2

Step 6: Attach the front plate(D1)to the left sofa.

NOTE:Do not tighten the screws all the way.

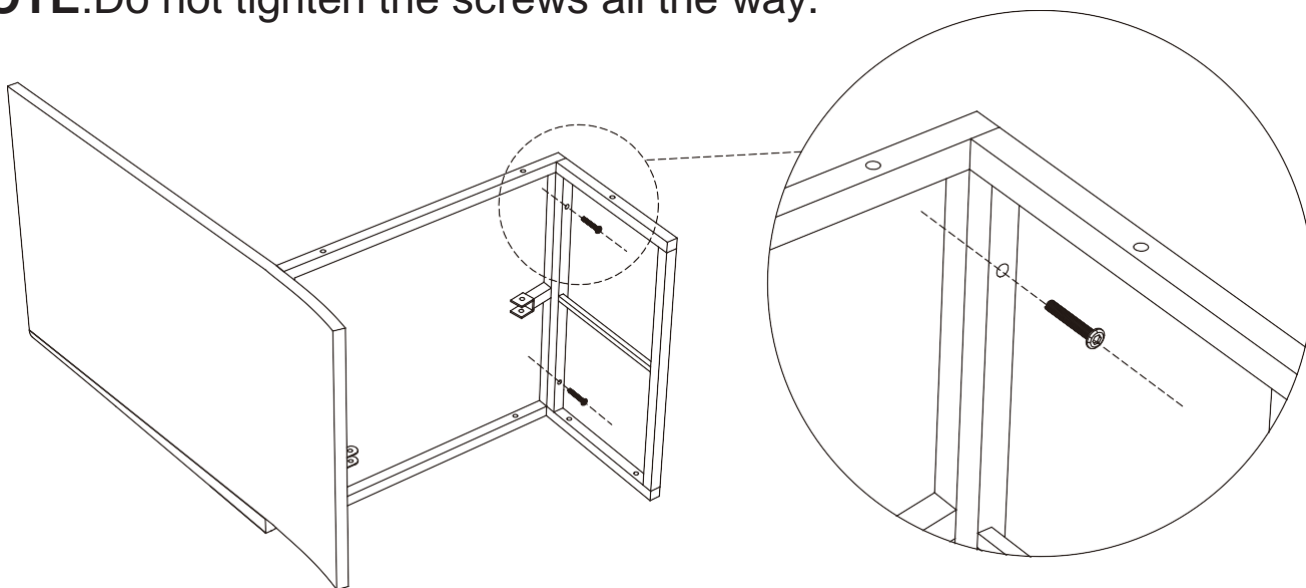

D1

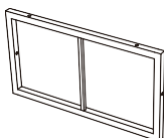

x1 Q4  M6x35 X2

Installation steps

Step 7: Install the right armrest(B1) on the right sofa.

NOTE: Do not tighten the screws all the way.

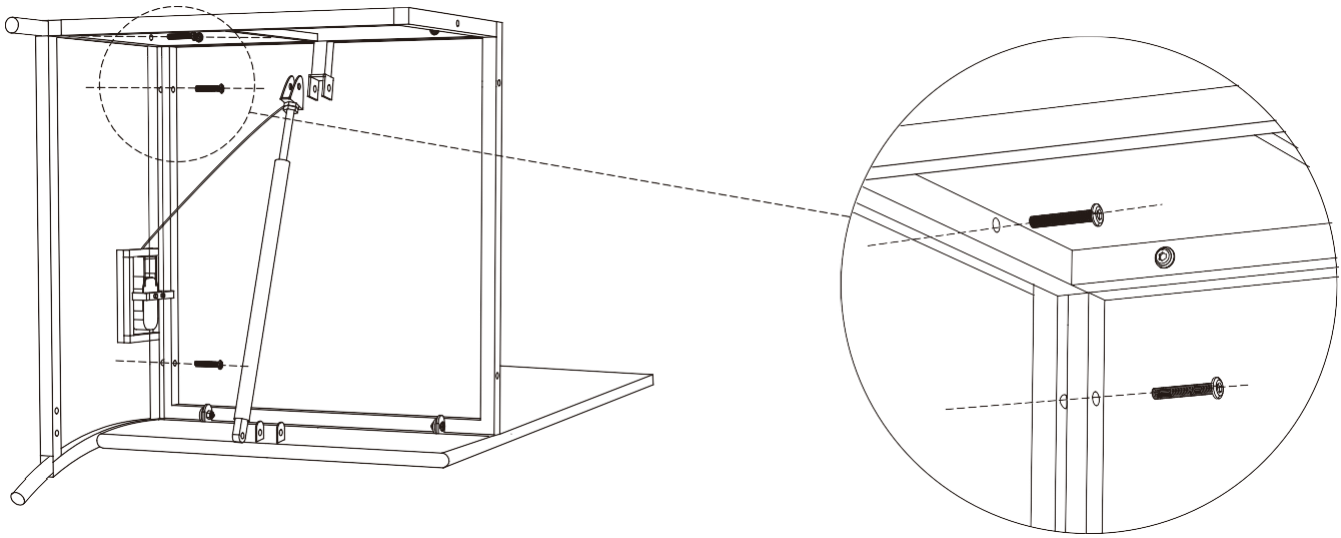

B1

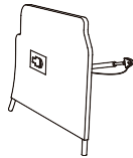

x1 Q4  M6x35 X3

Step 8: Connect the cylinder to the seat with the cylinder line on the side away from the seat.

NOTE: Do not tighten the screws all the way.

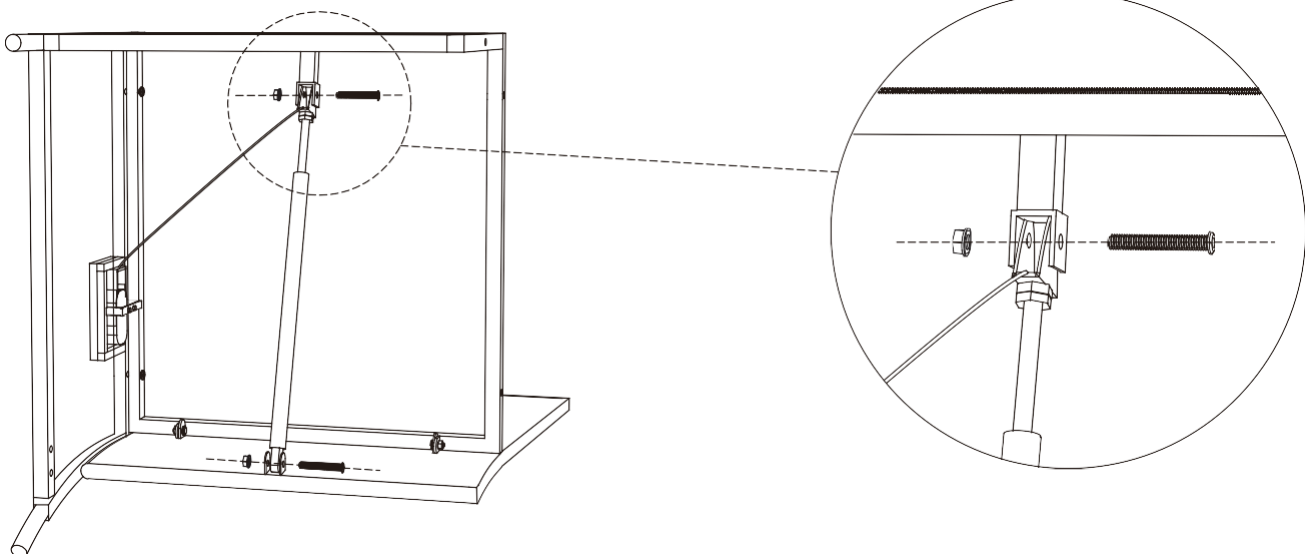

Q6

 M8x40

x2 S2



x2

Installation steps

Step 9: Install the left armrest(B3) on the left sofa.

NOTE: Do not tighten the screws all the way.

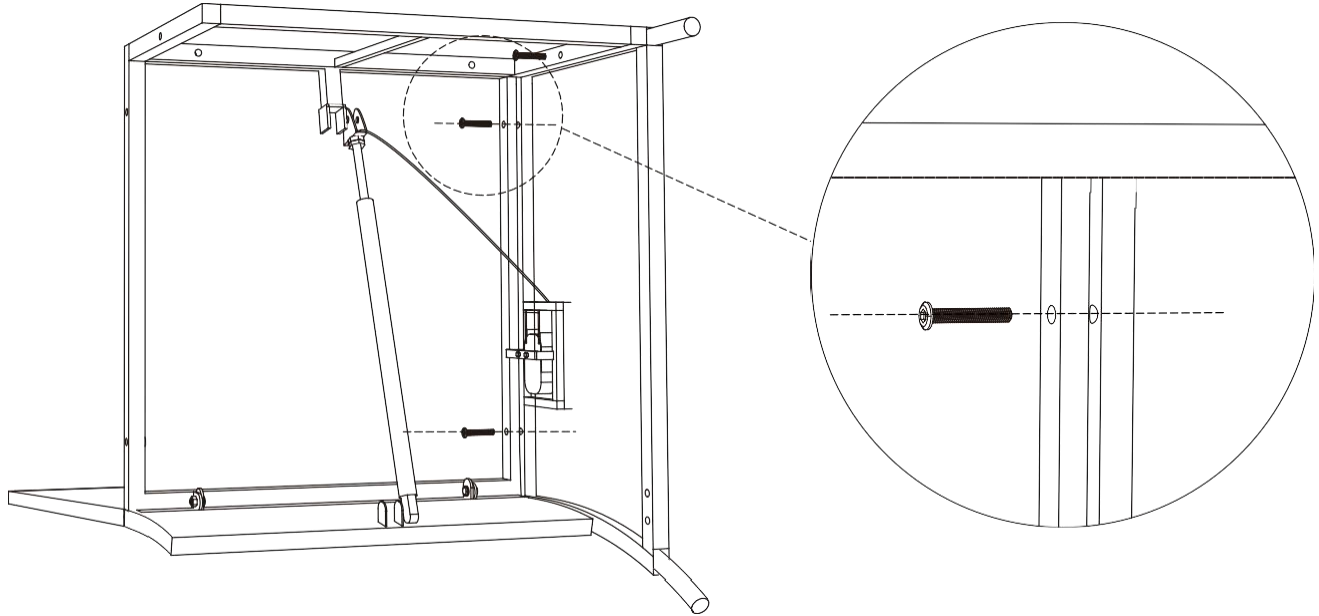

B3

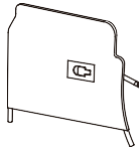

x1 Q4  M6x35 x3

Step 10: Connect the cylinder to the seat with the cylinder line on the side away from the seat.(Refer to step 7).

NOTE: Do not tighten the screws all the way.

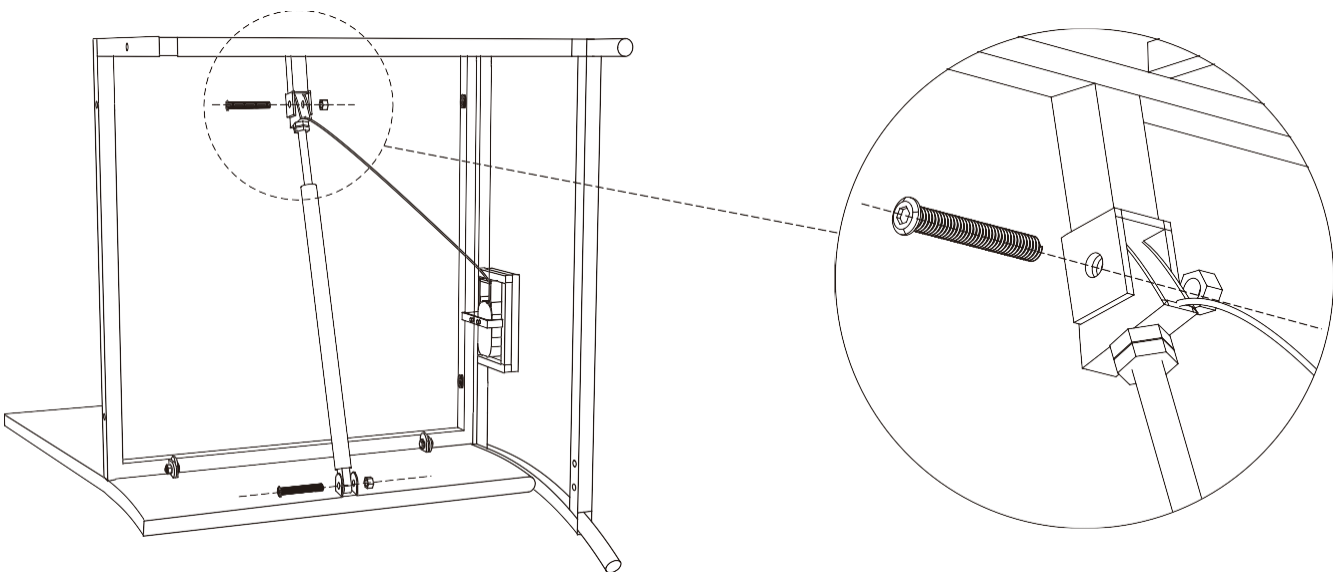

Q6

 M8x40

x2 S2





x2

Installation steps

Step 11: Assemble the three sofas.

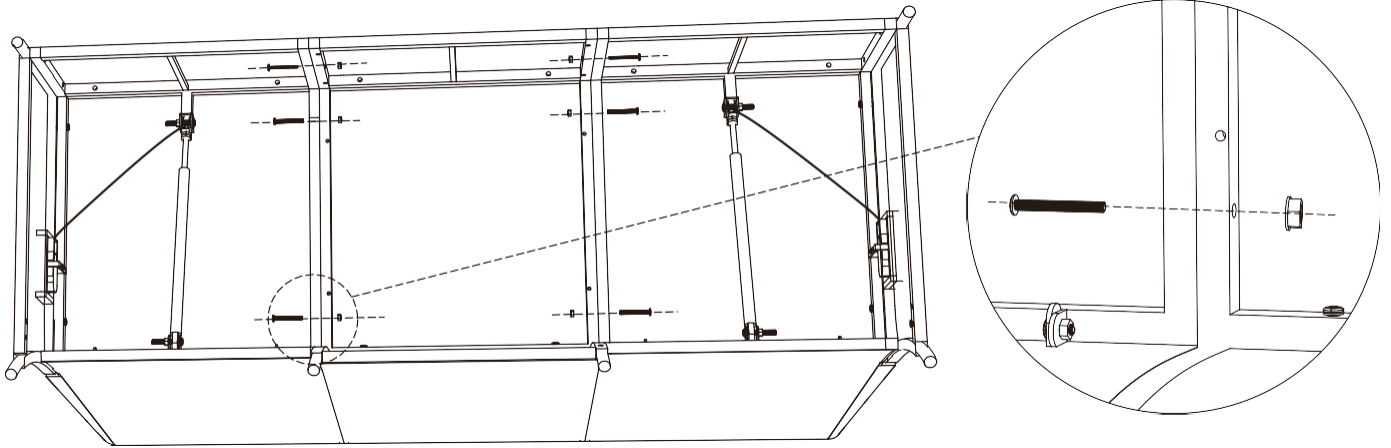
NOTE: Do not tighten the screws all the way.





Q4		M6x60	x6	S1		x6
----	---	-------	----	----	---	----

Step 12: Attach the left and right support legs(M,N)

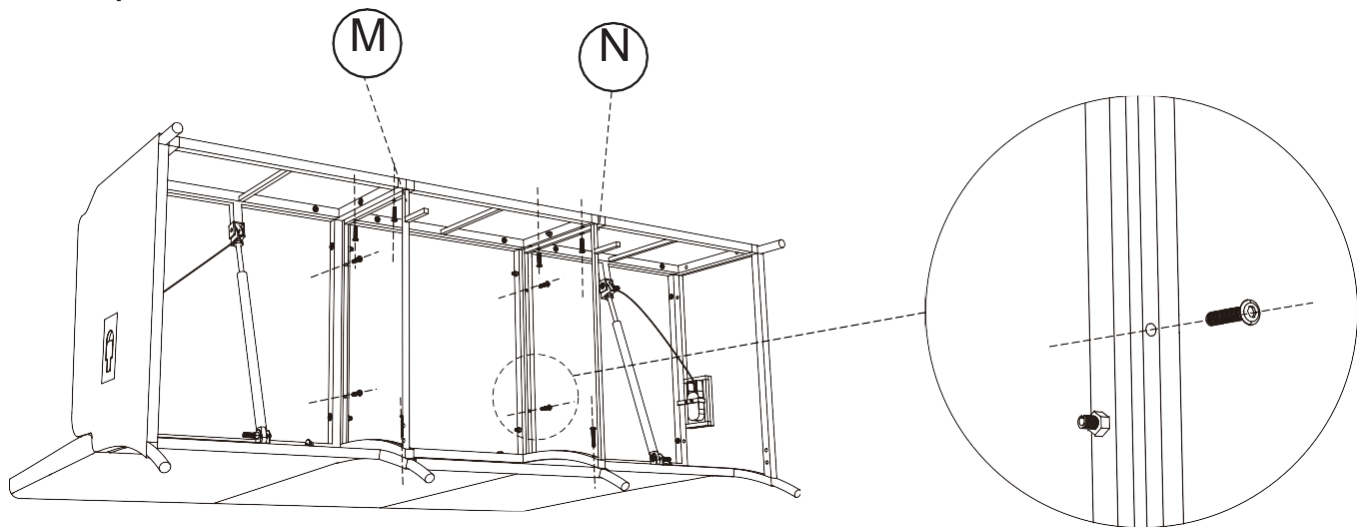
NOTE: Do not tighten the screws all the way. (M should be placed on the right and N should be placed on the left, and the position should not be misplaced.)



M		x1	N		x1	Q3		M6x30 X10
---	---	----	---	---	----	----	---	-----------

Installation steps

Step 13: Fix the Supporting Crossbar(E) under the seat.

NOTE: Please tighten all screws.

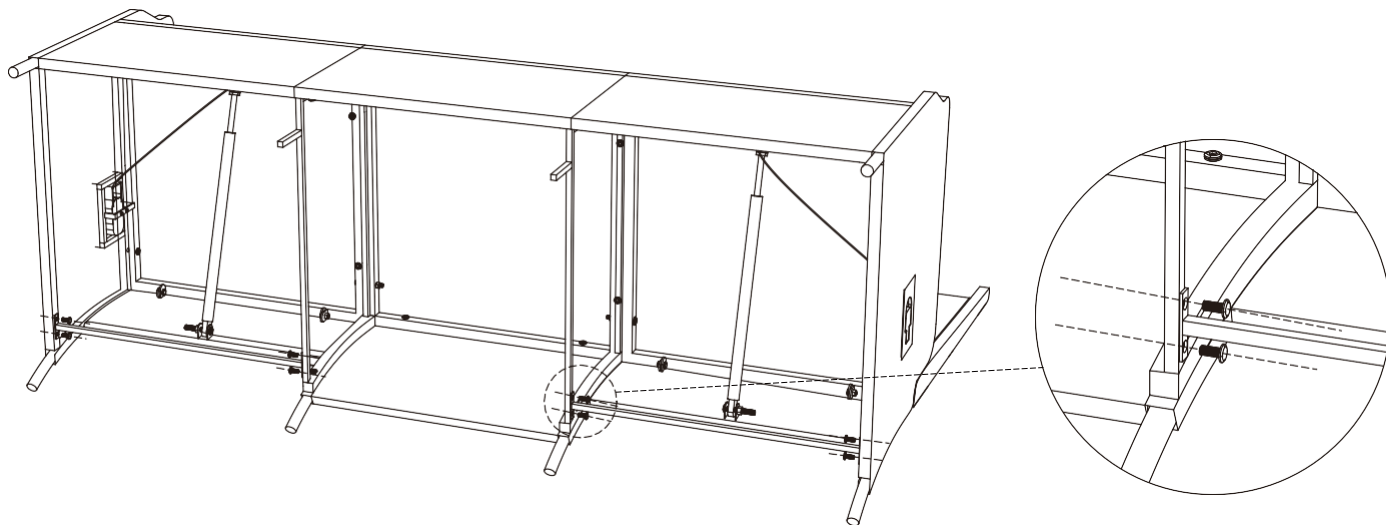

E



x2 Q1



M6x15 x8

Step 14: Place the cushion(P1) on. Attach the back cushions(O) to the sofa and tuck the olive buckle into the rattan.

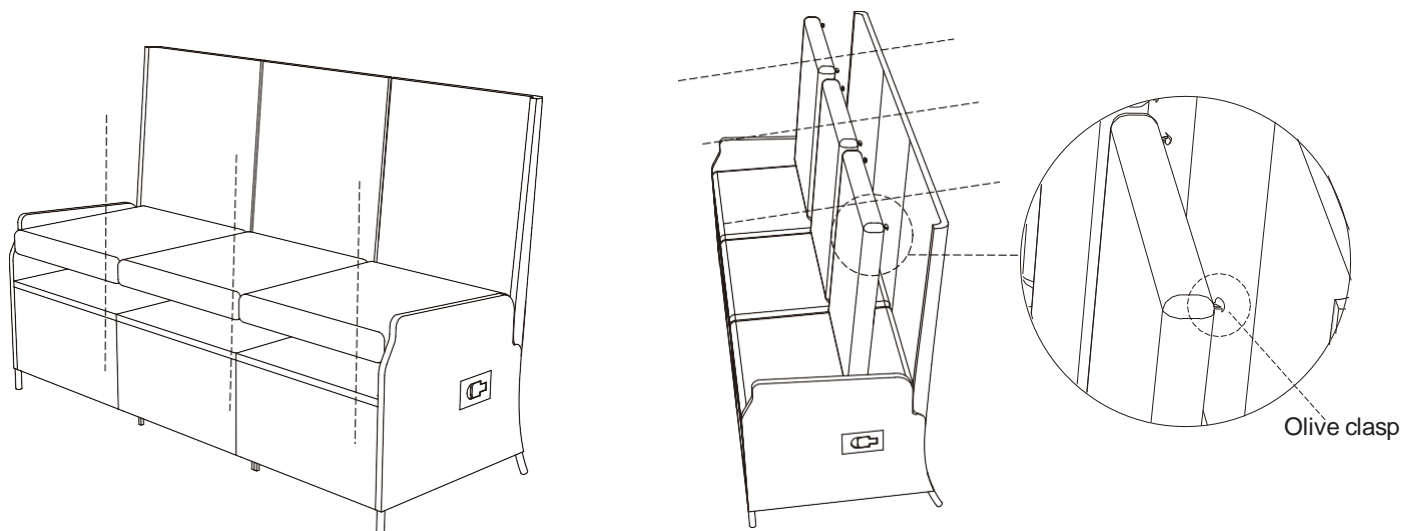

P1

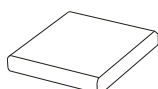

x3 O



x3

Installation steps

INSTRUCTIONS FOR USE: Pull the adjuster with the hands and push your back back firmly to lie down.

NOTE: The three-seater sofa has only two sides, which wear the top hats.

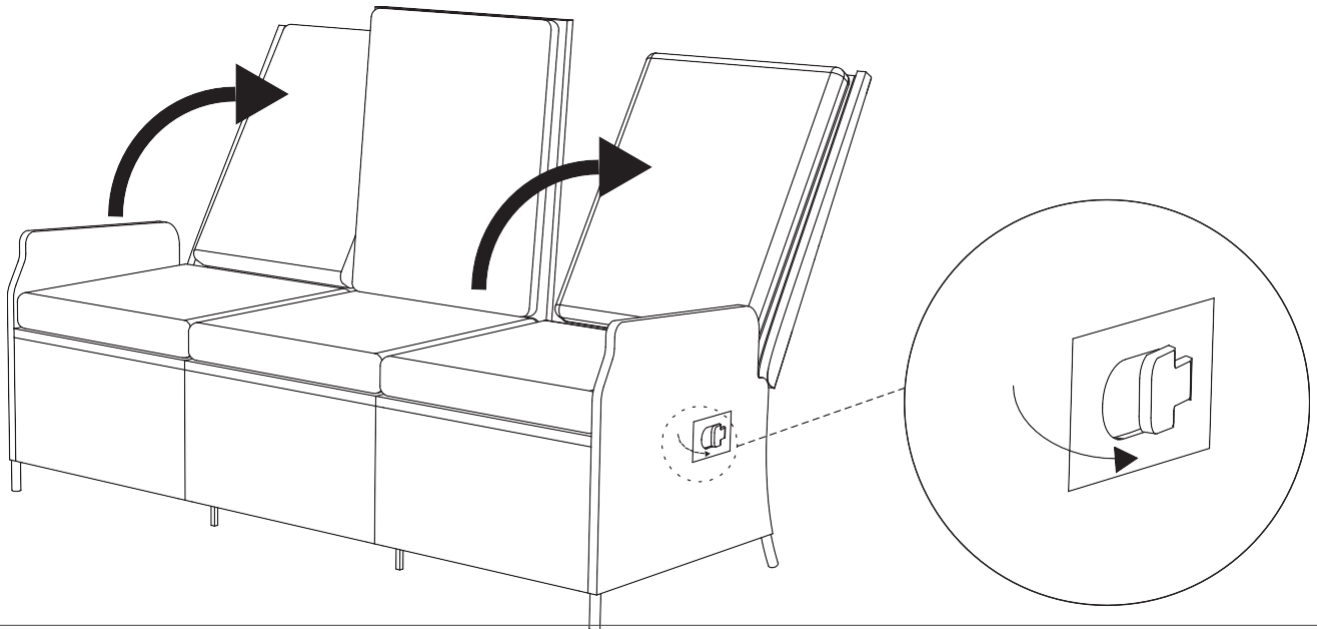

Installation steps

How To Assemble Footrests

Step 1: Connect the footrest legs(J) to the footrest base plate(K).

NOTE: Do not tighten the screws all the way.

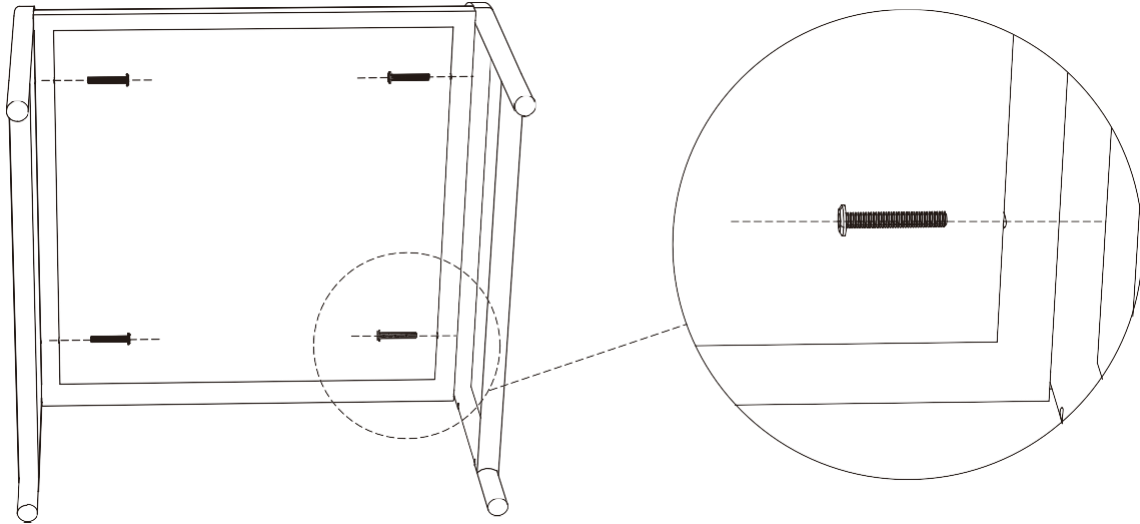

J		x2	K		x1	Q4		M6x35	x4
---	--	----	---	--	----	----	--	-------	----

Step 2: Attach the side panels (L) to the footrest.

NOTE: Please tighten all screws.

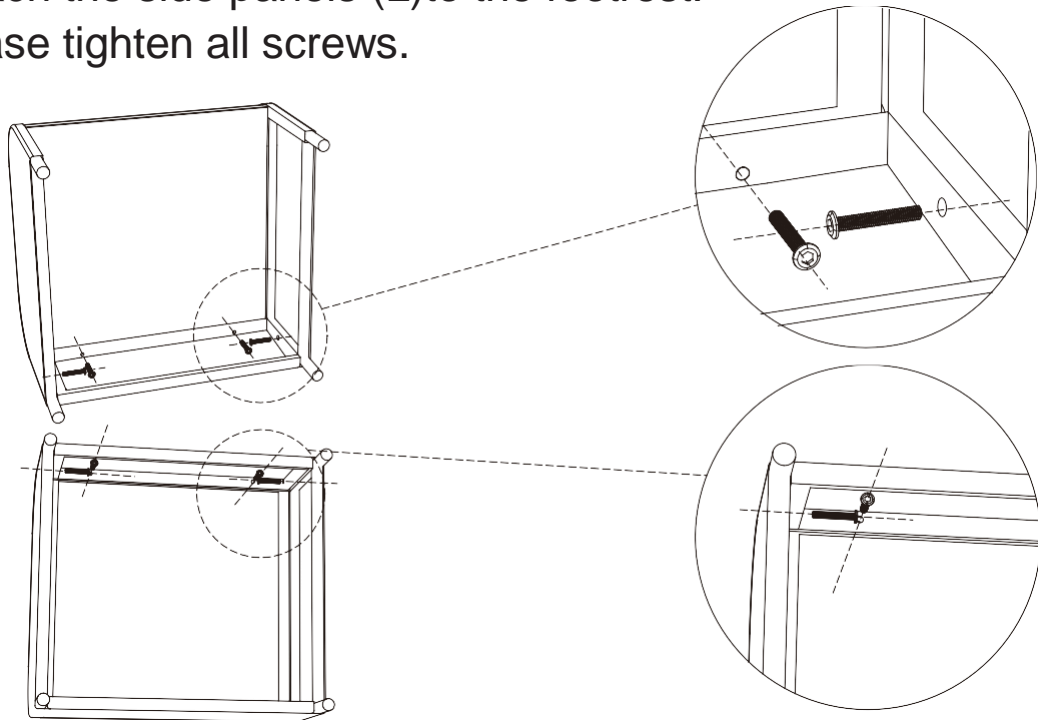

L		x2	Q4		M6x35	x8
---	--	----	----	--	-------	----

Installation steps

Step 3: Place the cushion(P2) on top.

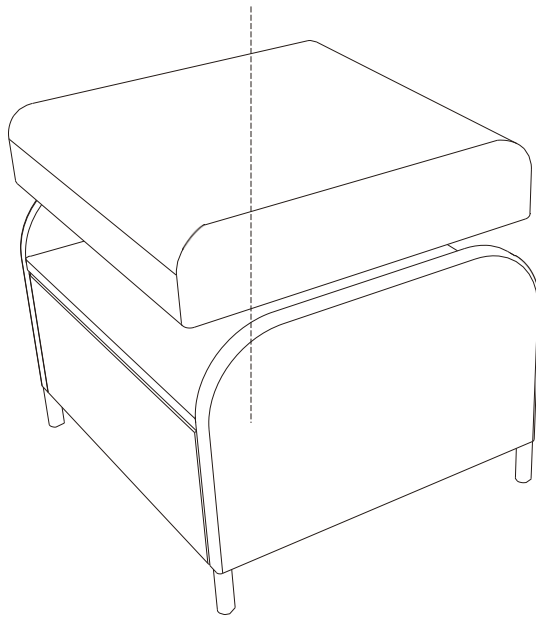

P2

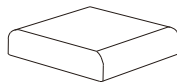

x1

Installation steps

How To Assemble The Square Coffee Table

Step 1: Connect the square coffee table table top(H1)with the square coffee table legs(F1).

NOTE:Do not tighten the screws all the way.

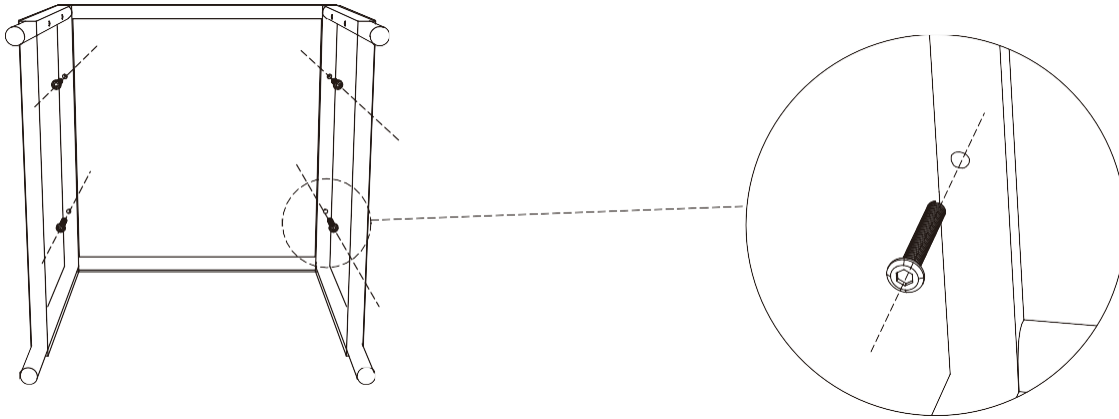

H1		x1	F1		x2	Q4		M6x35	x4
----	--	----	----	--	----	----	--	-------	----

Step 2: Install square coffee table side panel(G1).

NOTE:Please tighten all screws.

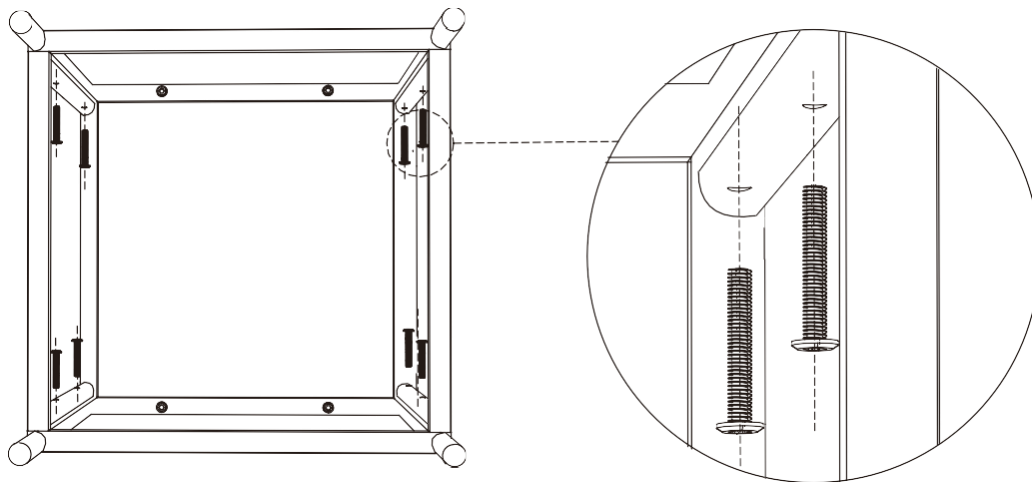

G1		x2	Q4		M6x35	x8
----	--	----	----	--	-------	----

Installation steps

Step 3: Place the square coffee table glass(I1).

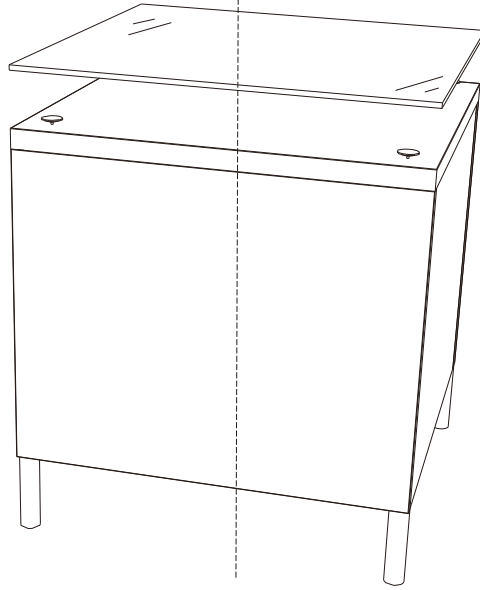

I1

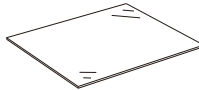

x1

Installation steps

How To Assemble The Long Coffee Table

Step 1: Connect the long coffee table tabletop(H2) to the long coffee table legs(F2).

NOTE: Do not tighten the screws all the way.

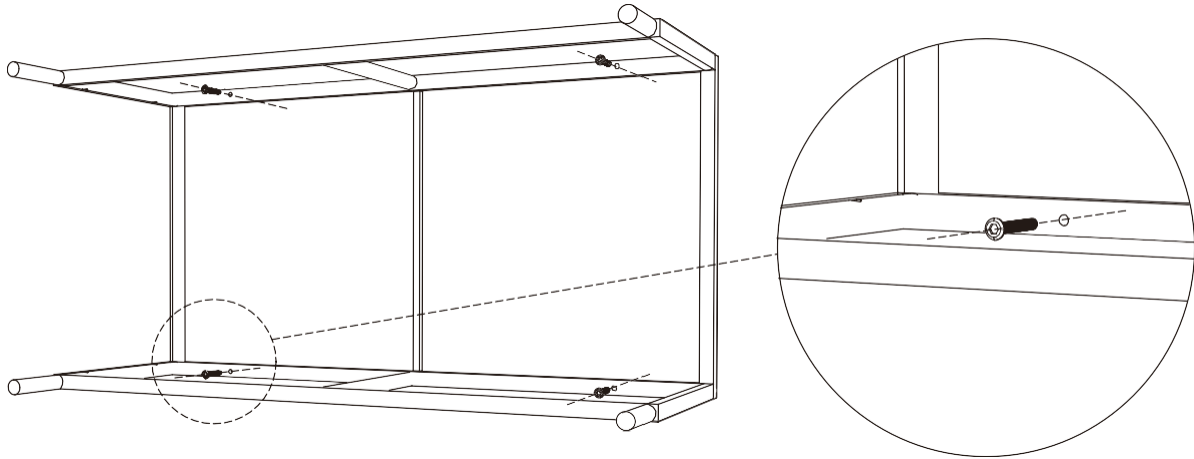

H2		x1	F2		x2	Q4		M6x35	x4
----	--	----	----	--	----	----	--	-------	----

Step 2: Install the long coffee table side panel(G2).

NOTE: Please tighten all screws.

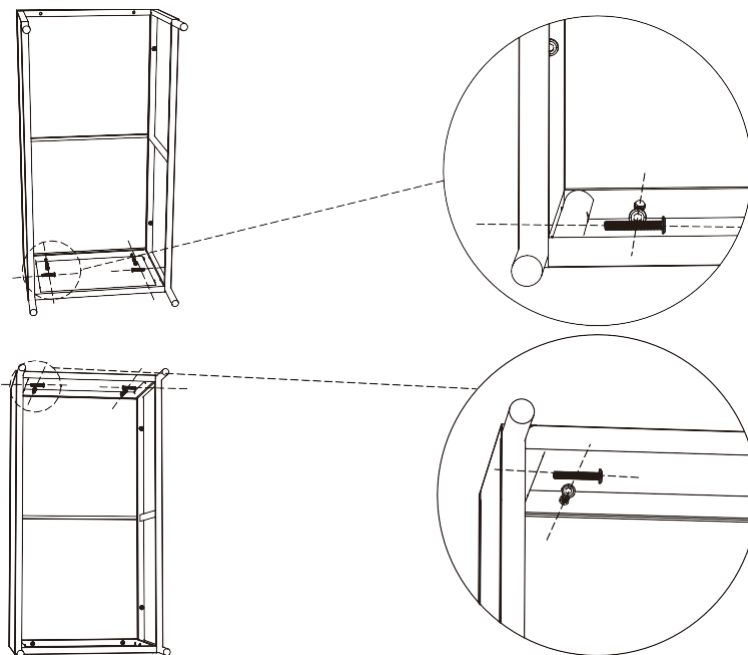

G2		x2	Q4		M6x35	x8
----	--	----	----	--	-------	----

Installation steps

Step 3: Place the long coffee table glass(I2).

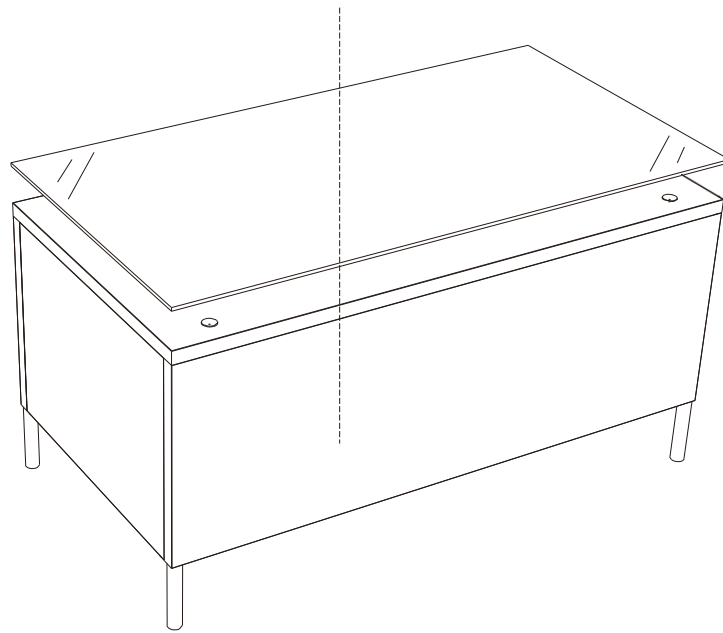

I2

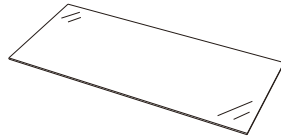

x1