









ASSEMBLY INSTRUCTION

SWIVEL COUNTER HEIGHT CHAIR

A Back With Seat  1pc	B Leg  4pcs	C Bottom Ring  1pc	D Allen Bolt 1/4x15mm  16pcs	E Allen Key 4mm  1pc
F Allen Bolt 4x30mm  4pcs	G Seat Panel  1pc	H Spring Washer Dia.10*1mm  16pcs	I Flat Washer Dia.15*1mm  16pcs	

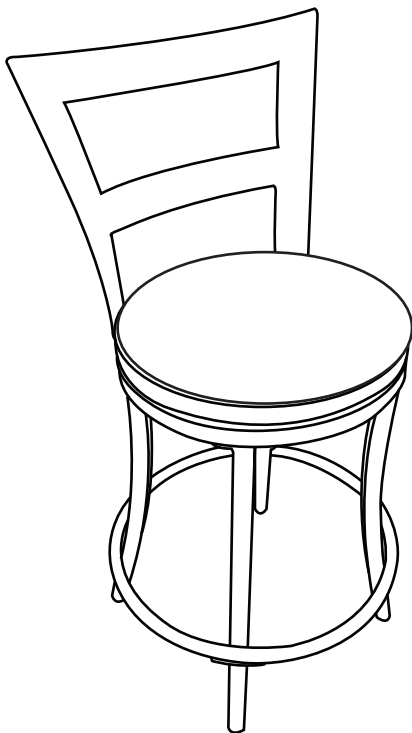

This page lists all the contents included in the box. Please take the time to identify the hardware as well as the individual components to this product. As you unpack and prepare for assembly, place the contents on a carpeted or padded area to protect them from damage.

- 1** ATTACHED THE LEG(B) TO THE BACK WITH SEAT(A),USE ALLEN BOLT(D) THROUGH FLAT WASHER(I) AND SPRING WASHER(H) ON HOLES OF THE BACK WITH SEAT(A), TURN THE ALLEN KEY (E) IN ALLEN BOLT (D);ATTACHED THE BOTTOM RING(C) TO THE LEG(B),USE ALLEN BOLT(D) THROUGH FLAT WASHER(I) AND SPRING WASHER(H) ON HOLES OF THE LEG(B),TURN THE ALLEN KEY(E) IN ALLEN BOLT(D).

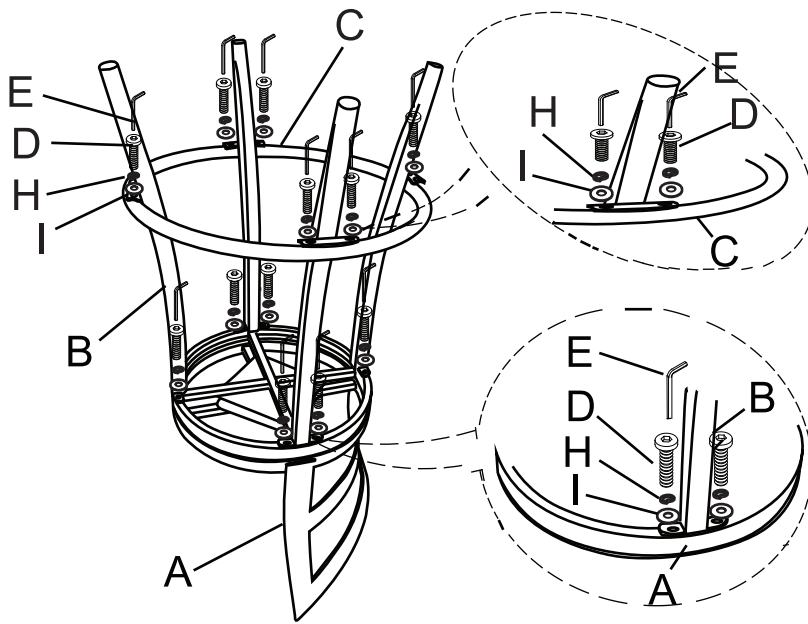

Take the Allen Wrench, and turn the bolts until the legs are secure. **DO NOT TIGHTEN COMPLETELY.** Stop when you feel you are adding force to tighten the bolt.

- 2** ATTACHED THE BACK WITH SEAT(A) TO THE SEAT PANEL BACK(G),TURN THE ALLEN BOLT(F) IN THE SEAT PANEL BACK(G).

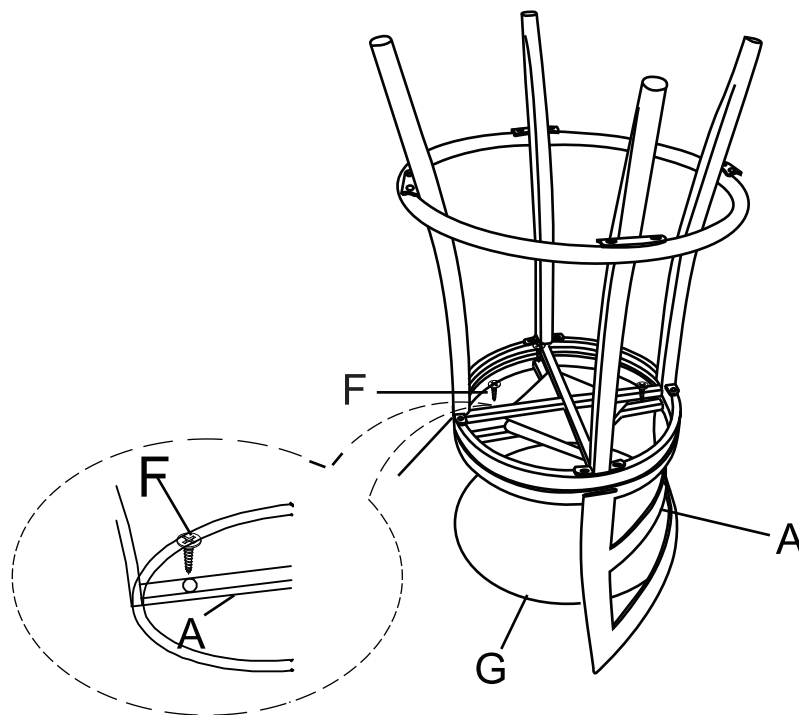

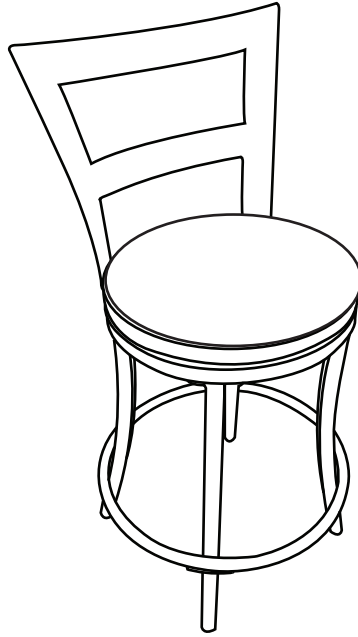

Stand chair up on an even surface and check that it is balanced.
If there is a slight wobble, apply downward pressure in the corner where a leg is uneven. Keeping pressure in that corner, tighten all bolts.
If balanced, apply downward pressure evenly in the center and tighten all bolts.
Do not over-tighten beyond hole depth.

Helpful Tip:

-Instead of applying downward pressure while reaching under to tighten bolts have someone sit in the chair while you tighten the bolts.

Cleaning & Care

Treat surface with care. Surface is resistant to scratches but is not scratch resistant. Clean surfaces with a dry or damp soft cloth. Do not use abrasive cleaners. Hardware may loosen over time. Periodically check that all connections are tight.